



US00D816037S

(12) **United States Design Patent** (10) **Patent No.:** **US D816,037 S**  
**Byrne et al.** (45) **Date of Patent:** **\*\* Apr. 24, 2018**

(54) **ELECTRICAL POWER UNIT FOR A WORK SURFACE**

(71) Applicants: **Norman R. Byrne**, Ada, MI (US);  
**Thomas A. Petersen**, Sand Lake, MI (US)

(72) Inventors: **Norman R. Byrne**, Ada, MI (US);  
**Thomas A. Petersen**, Sand Lake, MI (US)

(\*\*) Term: **15 Years**

(21) Appl. No.: **29/569,171**

(22) Filed: **Jun. 24, 2016**

**Related U.S. Application Data**

(62) Division of application No. 29/516,875, filed on Feb. 6, 2015, now Pat. No. Des. 762,175.

(51) **LOC (11) Cl.** ..... **13-03**

(52) **U.S. Cl.**  
USPC ..... **D13/137.2**

(58) **Field of Classification Search**  
USPC ..... D13/137.1-137.4, 138.1-138.2,  
D13/139.1-139.8, 110, 133, 108, 152;  
D14/435; 174/55; 307/23  
CPC ..... H01R 13/518; H01R 13/6272  
See application file for complete search history.

(56) **References Cited**

**U.S. PATENT DOCUMENTS**

676,622 A 6/1901 Gochnauer  
2,811,574 A 10/1957 Guerrero  
(Continued)

**FOREIGN PATENT DOCUMENTS**

WO 2008108739 9/2008

**OTHER PUBLICATIONS**

Co-pending and commonly-owned Design U.S. Appl. No. 29/516,863, filed Feb. 6, 2015, including replacement drawings filed by Preliminary Amendment on Oct. 30, 2015.

(Continued)

*Primary Examiner* — Rhea Shields

(74) *Attorney, Agent, or Firm* — Gardner, Linn, Burkhardt & Flory, LLP

(57) **CLAIM**

The ornamental design for an electrical power unit for a work surface, as shown and described.

**DESCRIPTION**

FIG. 1 is a front perspective view of a first embodiment of the electrical power unit for a work surface showing our new design;  
FIG. 2 is a front elevation thereof;  
FIG. 3 is a top plan view thereof;  
FIG. 4 is a front perspective view of a second embodiment of the electrical power unit for a work surface showing our new design;  
FIG. 5 is a front elevation thereof;  
FIG. 6 is a top plan view thereof;  
FIG. 7 is a front perspective view of a third embodiment of the electrical power unit for a work surface showing our new design;  
FIG. 8 is a front elevation thereof;  
FIG. 9 is a top plan view thereof;  
FIG. 10 is a front perspective view of a fourth embodiment of the electrical power unit for a work surface showing our new design;  
FIG. 11 is a front elevation thereof;  
FIG. 12 is a top plan view thereof;  
FIG. 13 is a front perspective view of a fifth embodiment of the electrical power unit for a work surface showing our new design;  
FIG. 14 is a front elevation thereof; and,  
FIG. 15 is a top plan view thereof.  
In the drawings, the broken lines are for the purpose of illustrating environment only and form no part of the claimed design.

**1 Claim, 8 Drawing Sheets**

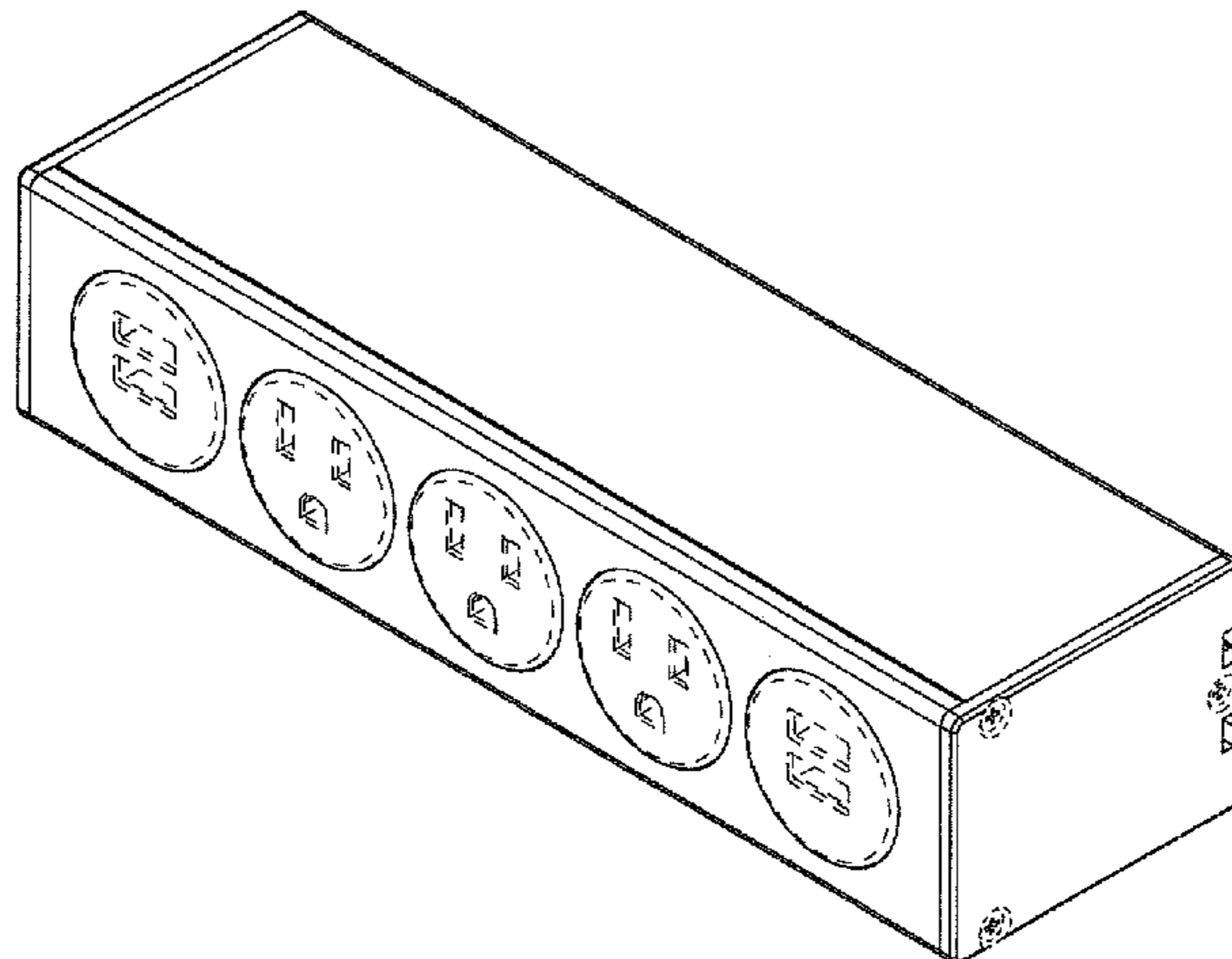

(56)

References Cited

U.S. PATENT DOCUMENTS

2,861,857 A	11/1958	Lee		D446,188 S	8/2001	Gershfeld	
3,049,688 A	8/1962	Sinopoli		D446,189 S	8/2001	Lee	
D195,463 S	6/1963	Tamarin		D446,503 S	8/2001	Lee	
3,131,512 A	5/1964	MacLeod, Jr.		D446,504 S	8/2001	Lee	
3,353,137 A	11/1967	Miller		6,290,518 B1	9/2001	Byrne	
3,433,886 A	3/1969	Myers		D449,819 S	10/2001	Gershfeld	
3,622,684 A	11/1971	Press		6,302,743 B1	10/2001	Chiu et al.	
3,646,244 A	2/1972	Cole		6,332,794 B1	12/2001	Tzeng Jeng	
3,794,956 A	2/1974	Dubreuil		6,379,182 B1	4/2002	Byrne	
3,892,095 A	7/1975	Vankuik		D457,137 S	5/2002	Gershfeld	
3,972,579 A	8/1976	Kohaut		6,386,921 B1 *	5/2002	Casari	H01R 31/06 439/651
3,992,070 A	11/1976	Dunn		D464,627 S	10/2002	Metcalf	
4,059,321 A	11/1977	Rasmussen		D467,875 S	12/2002	Barger et al.	
4,240,688 A	12/1980	Sotolongo		6,492,591 B1	12/2002	Metcalf	
4,272,643 A	6/1981	Carroll		D470,460 S *	2/2003	Yu	D13/139.8
4,323,723 A	4/1982	Fork et al.		D472,213 S	3/2003	Byrne	
4,372,629 A	2/1983	Propst		D484,098 S	12/2003	Lee	
4,463,998 A	8/1984	Reavis et al.		D486,793 S	2/2004	Gershfeld	
4,551,198 A	11/1985	Wiley		6,717,053 B2	4/2004	Rupert	
4,551,577 A	11/1985	Byrne		6,830,477 B2	12/2004	Vander Vorste et al.	
D288,298 S	2/1987	Yang		6,875,051 B2	4/2005	Pizak	
4,747,788 A	5/1988	Byrne		D505,917 S *	6/2005	Murphy	D13/139.6
4,792,881 A	12/1988	Wilson		6,971,911 B2	12/2005	Ramsey et al.	
4,828,513 A	5/1989	Morrison		7,001,211 B2	2/2006	Lichtscheidl et al.	
D301,576 S	6/1989	Wang		7,083,421 B1	8/2006	Mori	
D306,012 S	2/1990	Oesterheld et al.		D528,508 S	9/2006	Tan et al.	
4,967,041 A	10/1990	Bowman		7,112,097 B1	9/2006	Lam	
4,984,982 A	1/1991	Brownlie		D535,257 S	1/2007	Byrne	
4,986,762 A	1/1991	Keith		7,223,122 B2	5/2007	Mori	
5,023,396 A	6/1991	Bartee		D558,676 S	1/2008	Fort et al.	
5,114,365 A	5/1992	Thompson		7,500,854 B2	3/2009	Gottstein	
5,122,069 A	6/1992	Brownlie		D591,233 S	4/2009	Kagami et al.	
5,195,288 A	5/1993	Penczak		D611,428 S *	3/2010	Chapman	D13/154
5,230,552 A	6/1993	Schipper		7,736,178 B2	6/2010	Byrne	
5,231,562 A	6/1993	Pierce		D626,071 S	10/2010	Su et al.	
D350,939 S	9/1994	Rossmann et al.		D636,345 S *	4/2011	Cullen	D13/137.4
5,350,310 A	9/1994	Chen		D636,728 S	4/2011	Terleski et al.	
5,351,173 A	9/1994	Byrne		D642,983 S *	8/2011	Finlayson	D13/147
D353,363 S	12/1994	Toby		D643,807 S *	8/2011	Jiang	D13/103
D355,890 S	2/1995	Lentz		D649,515 S *	11/2011	Ullrich	D13/139.8
5,387,761 A	2/1995	Simonis		D651,974 S	1/2012	Benedetti	
5,429,518 A	7/1995	Chen		D653,215 S	1/2012	Lam	
D368,893 S	4/1996	Harwood et al.		D654,432 S *	2/2012	Brookshire	D13/110
5,516,298 A	5/1996	Smith		8,221,158 B2	7/2012	Liao	
D370,622 S	6/1996	Byrne		D665,355 S	8/2012	Byrne	
D372,018 S	7/1996	Byrne		8,283,802 B2 *	10/2012	Jansma	H01R 13/6272 307/23
5,566,053 A	10/1996	Chou		8,287,292 B2	10/2012	Byrne	
D382,855 S	8/1997	Salmond et al.		D673,909 S *	1/2013	Zaslavsky	D13/110
D389,459 S	1/1998	Byrne		D674,754 S	1/2013	Zanoni et al.	
5,705,772 A	1/1998	Brown		D681,551 S *	5/2013	Zaslavsky	D13/110
5,709,156 A	1/1998	Gevaert		D682,789 S *	5/2013	Au	D13/137.3
D392,254 S	3/1998	Gevaert		8,480,429 B2	7/2013	Byrne	
5,738,548 A	4/1998	Rutulante		8,496,492 B2	7/2013	Byrne	
5,748,424 A	5/1998	Hung		D692,825 S	11/2013	Izen et al.	
5,757,668 A	5/1998	Zhu		D693,770 S *	11/2013	Miller	D13/139.2
5,765,932 A	6/1998	Domina et al.		D701,834 S *	4/2014	Lee	D13/137.2
D401,220 S *	11/1998	Dwight	D13/139.6	D702,184 S *	4/2014	Jacobs	D13/110
D401,555 S *	11/1998	Tam	D13/137.3	D714,290 S *	9/2014	Tanaka	D14/422
D405,416 S	2/1999	Byrne		D736,159 S	8/2015	Byrne et al.	
D407,374 S	3/1999	Byrne		9,148,006 B2	9/2015	Byrne et al.	
D412,698 S	8/1999	Byrne		D744,953 S *	12/2015	Byrne	D13/139.4
D413,571 S	9/1999	Glass		D758,967 S *	6/2016	Chen	D13/110
5,964,618 A	10/1999	McCarthy		D761,732 S *	7/2016	Byrne	D13/137.2
5,984,728 A	11/1999	Chen et al.		D762,175 S *	7/2016	Byrne	D13/137.2
6,004,157 A	12/1999	Glass		D780,122 S *	2/2017	Irons	H05K 7/1492 D13/139.8
6,028,267 A	2/2000	Byrne		D788,709 S *	6/2017	Yeo	D13/137.2
6,081,356 A	6/2000	Branc et al.		D790,465 S *	6/2017	Zhao	D13/110
D427,454 S *	7/2000	Munch	D13/184	D795,190 S *	8/2017	Tzeng	D13/110
D436,922 S	1/2001	Stekelenburg		D796,437 S *	9/2017	Banayan	D13/110
6,220,880 B1	4/2001	Lee et al.		2006/0258195 A1	11/2006	Schwartz et al.	
6,200,159 B1	5/2001	Chou		2007/0275594 A1	11/2007	Greenberg	
D444,126 S	6/2001	Chura et al.					
D445,403 S *	7/2001	Veino	D13/139.8				

(56)

**References Cited**

U.S. PATENT DOCUMENTS

2009/0294147 A1 12/2009 Stockton  
2014/0292289 A1 10/2014 Gelonese

OTHER PUBLICATIONS

Co-pending and commonly-owned Design U.S. Appl. No.  
29/516,875, filed Feb. 6, 2015, including replacement drawings  
filed on Apr. 19, 2016.

\* cited by examiner

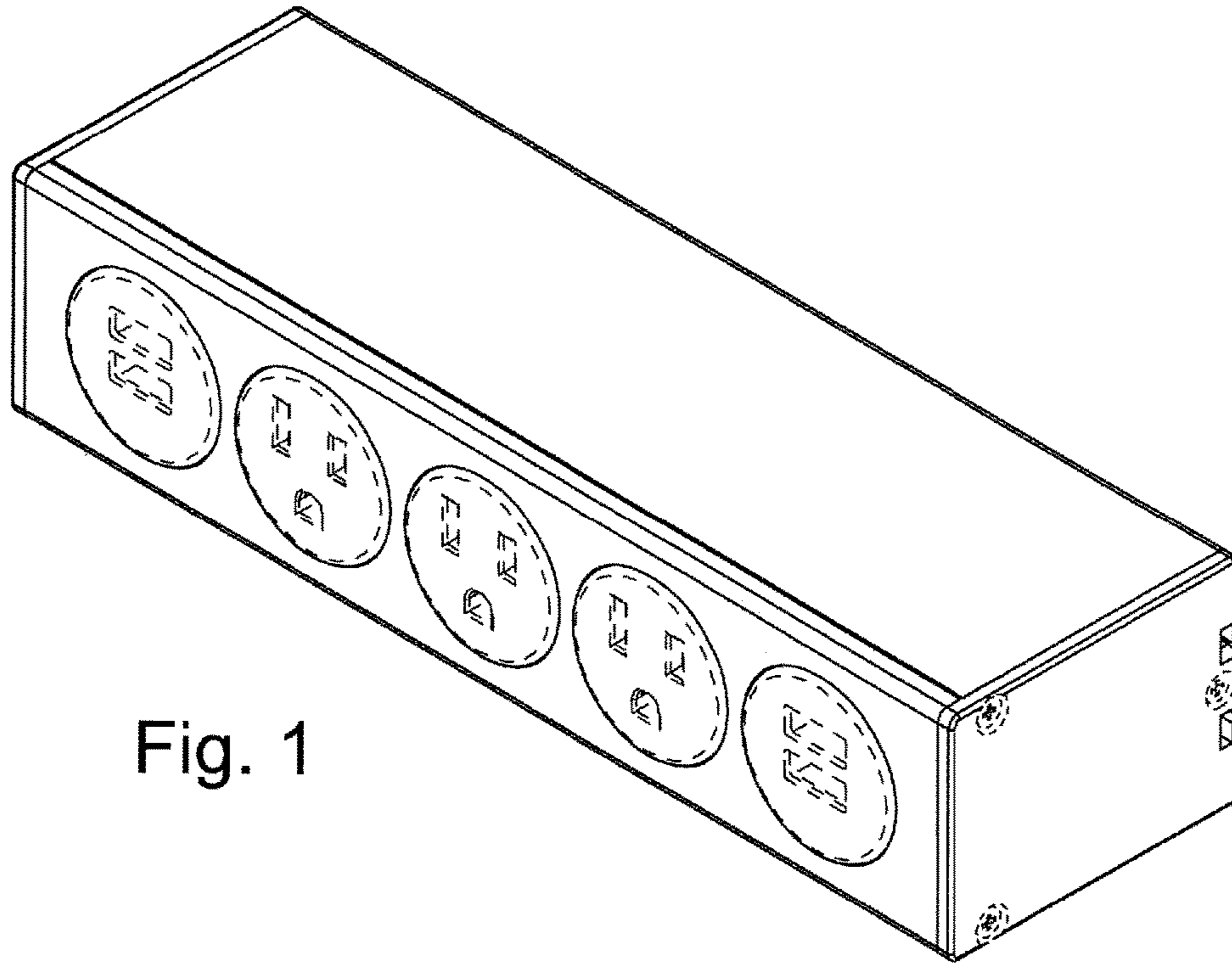

Fig. 1

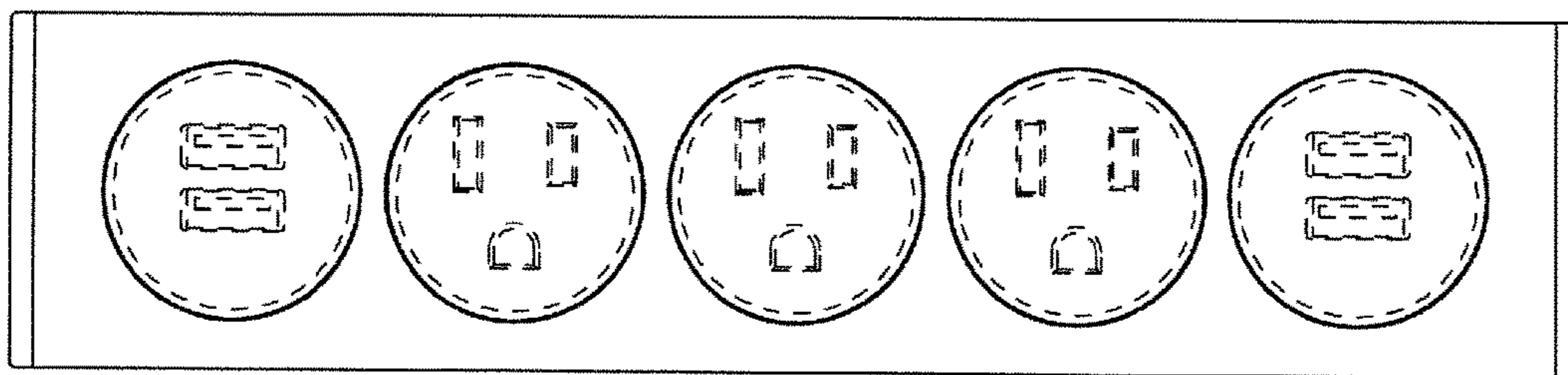

Fig. 2

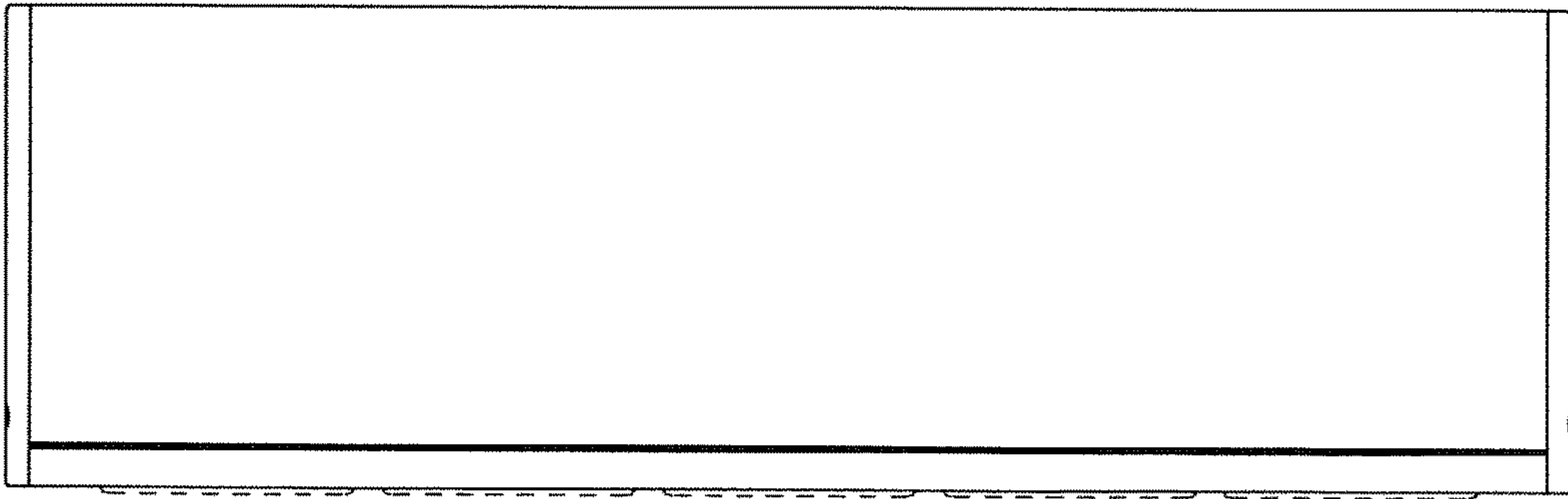

Fig. 3

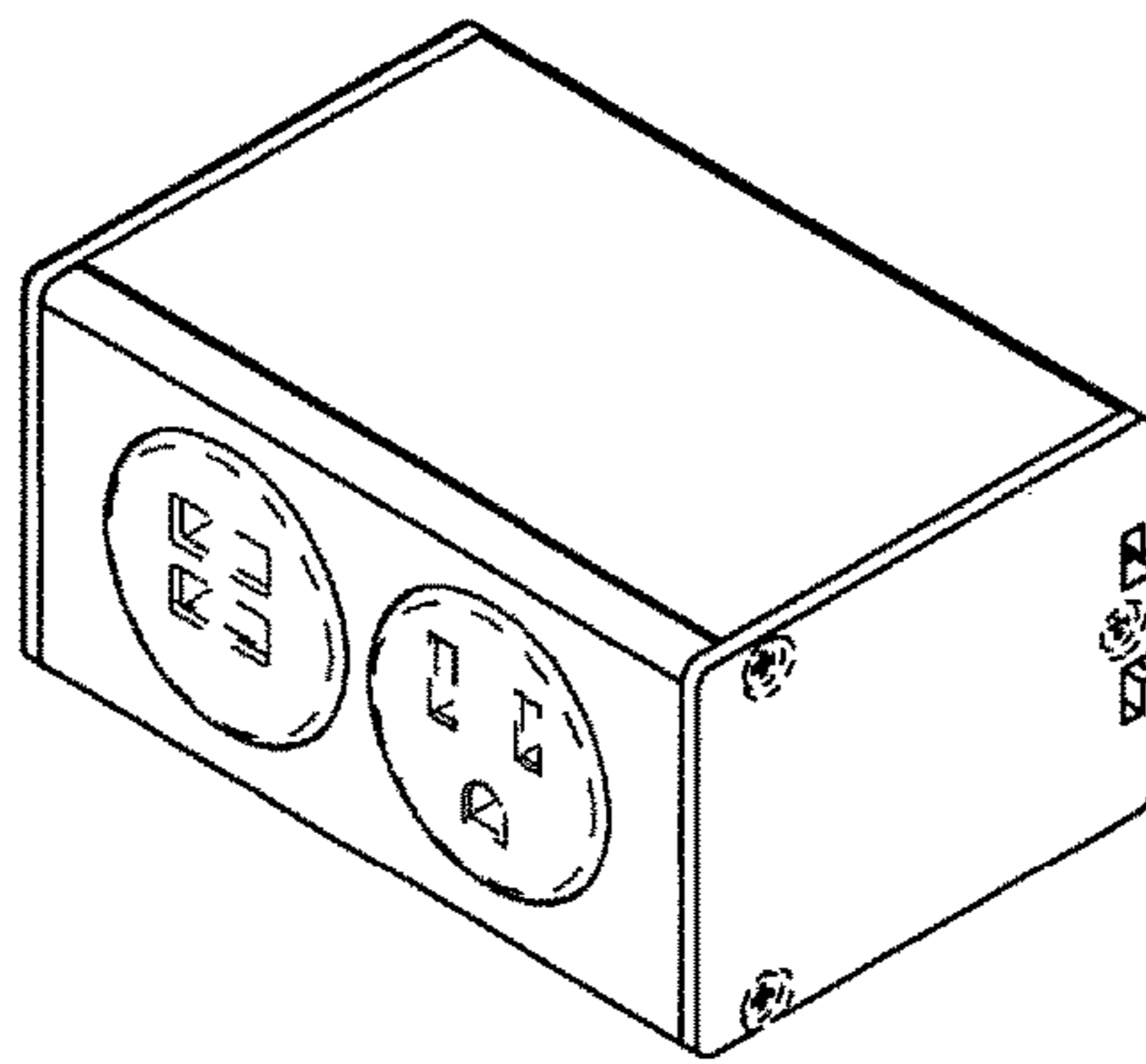

Fig. 4

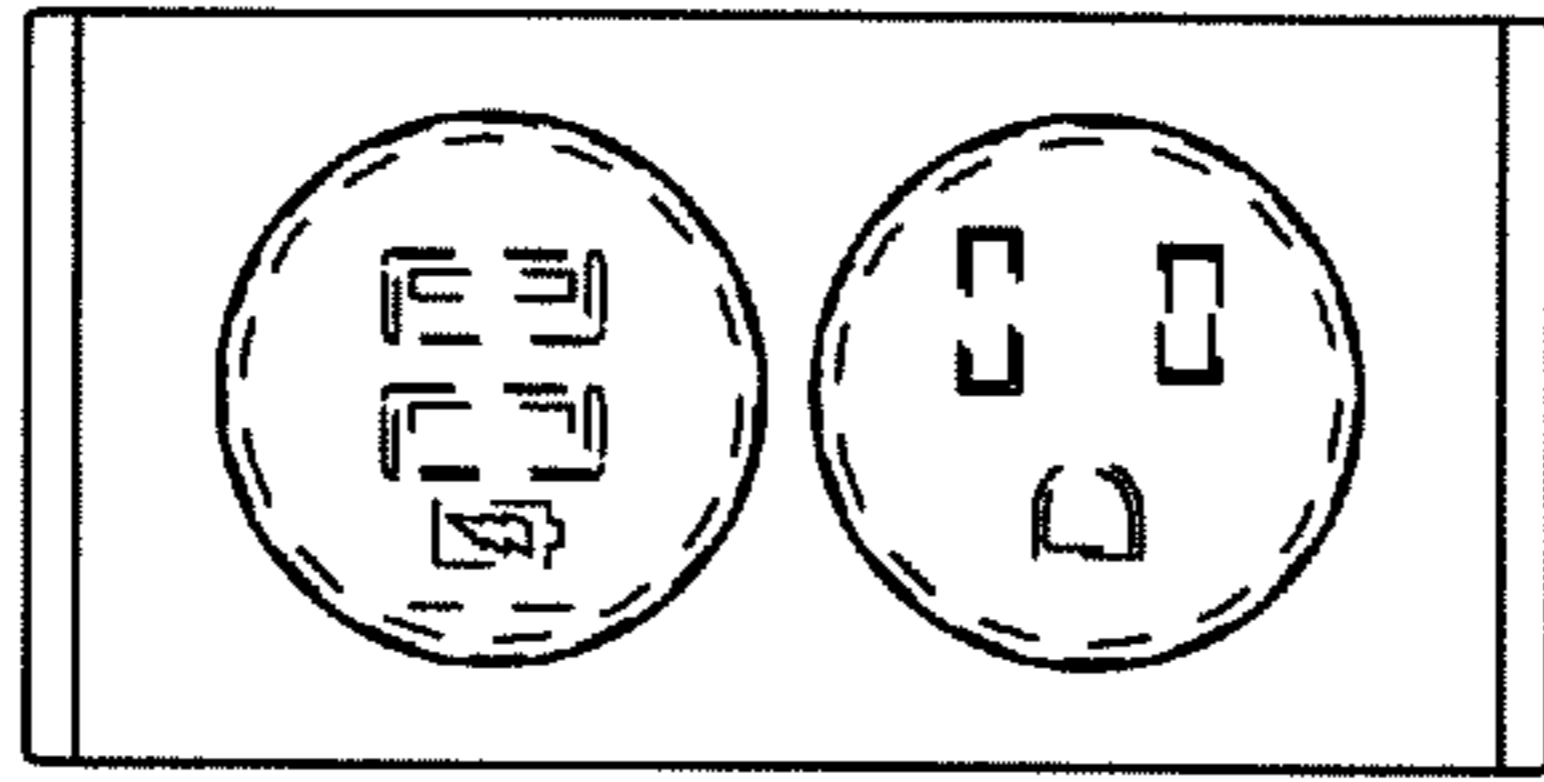

Fig. 5

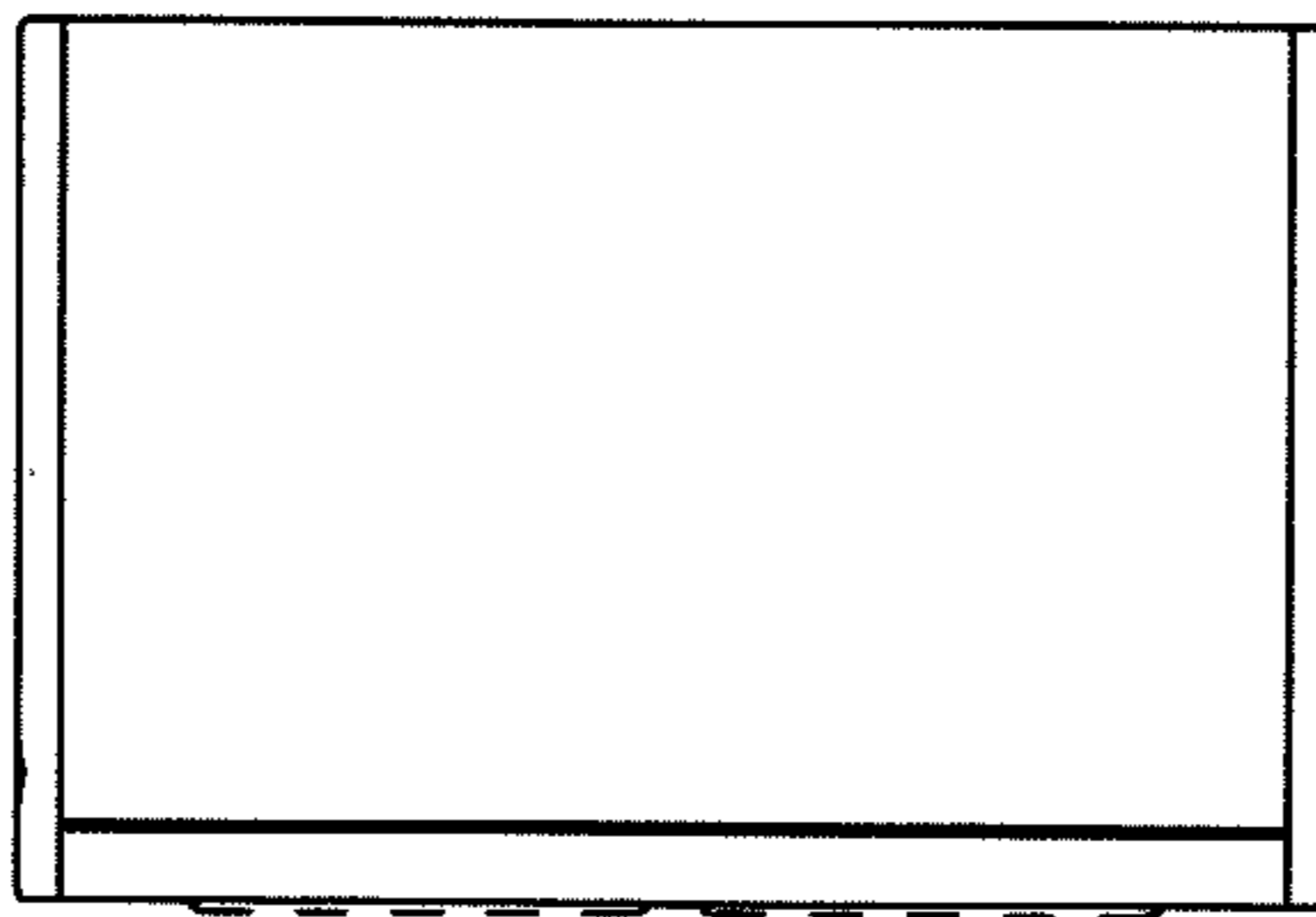

Fig. 6

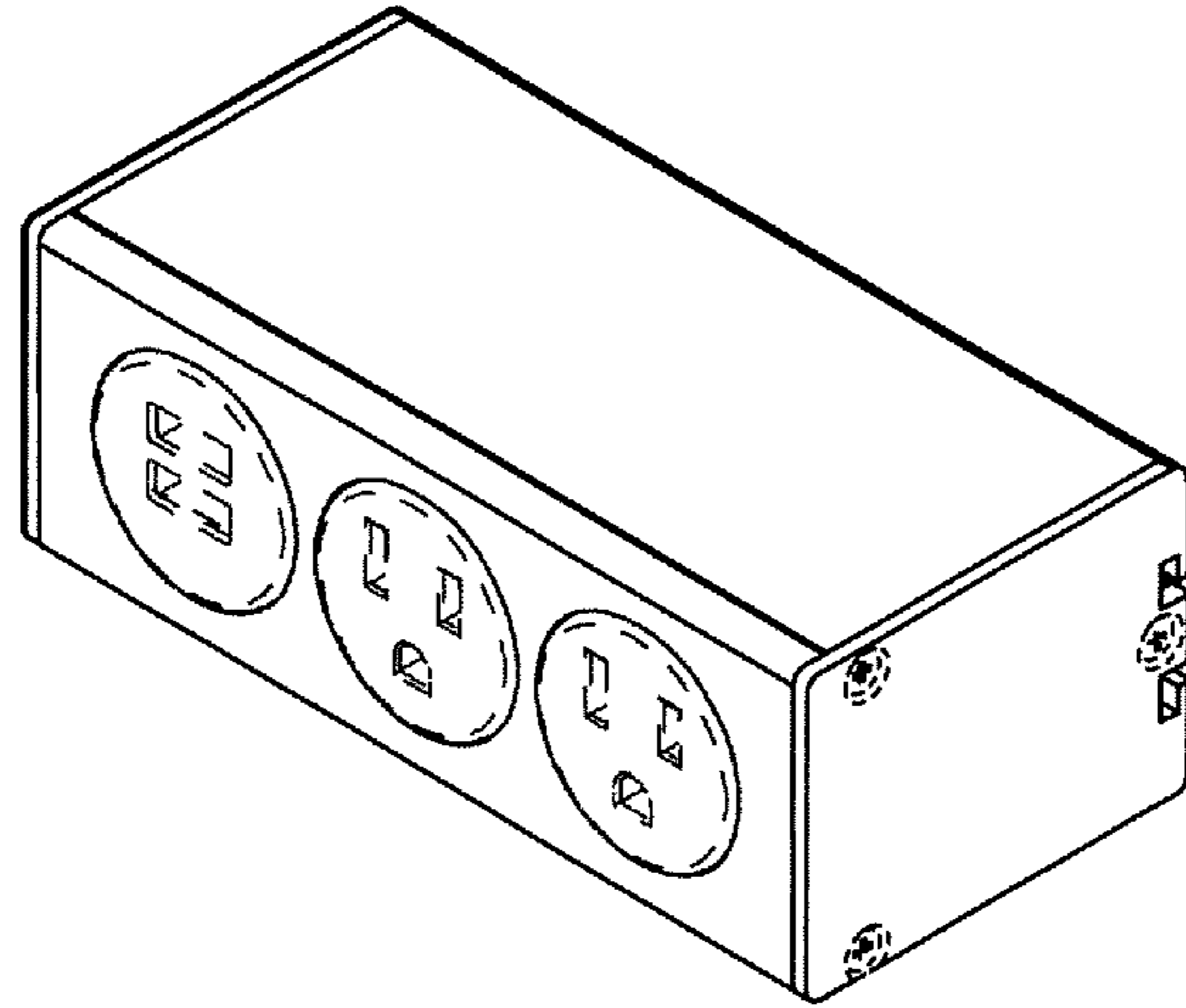

Fig. 7

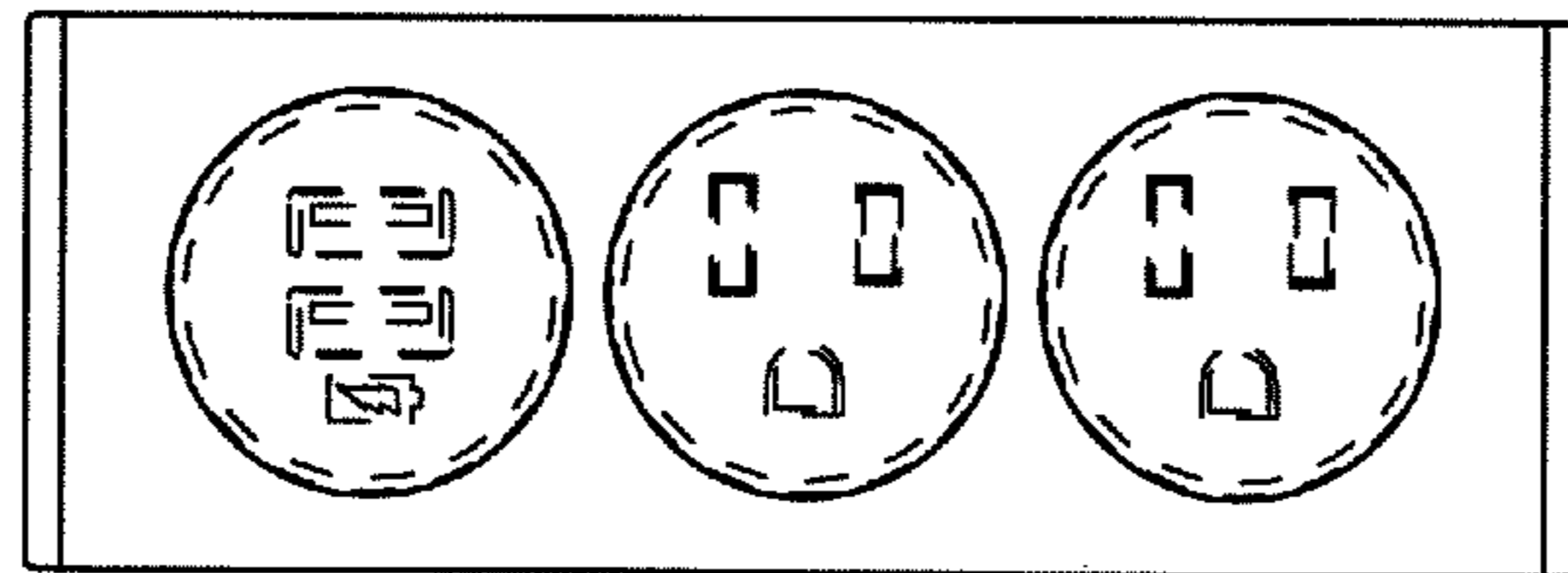

Fig. 8

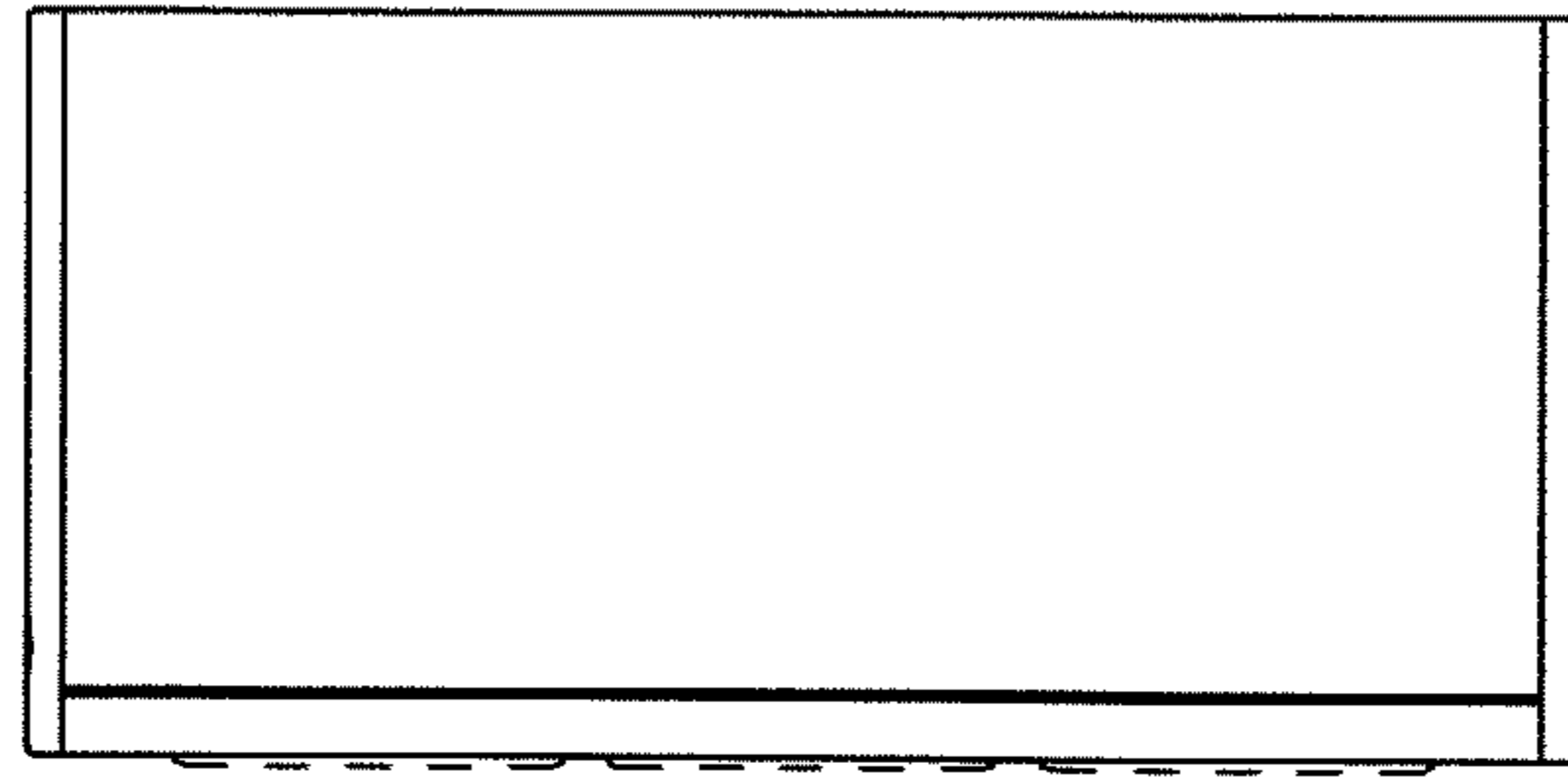

Fig. 9

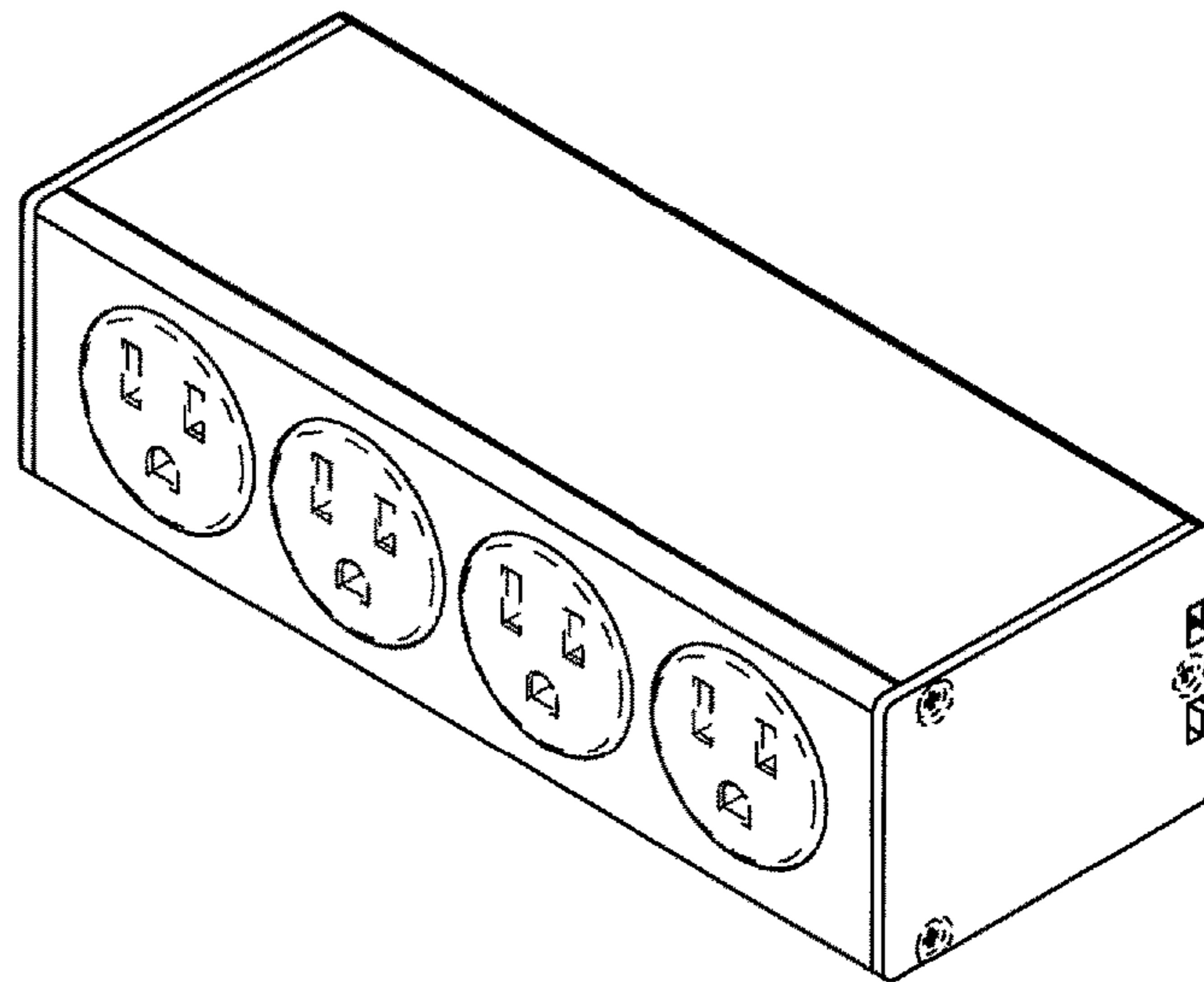

Fig. 10



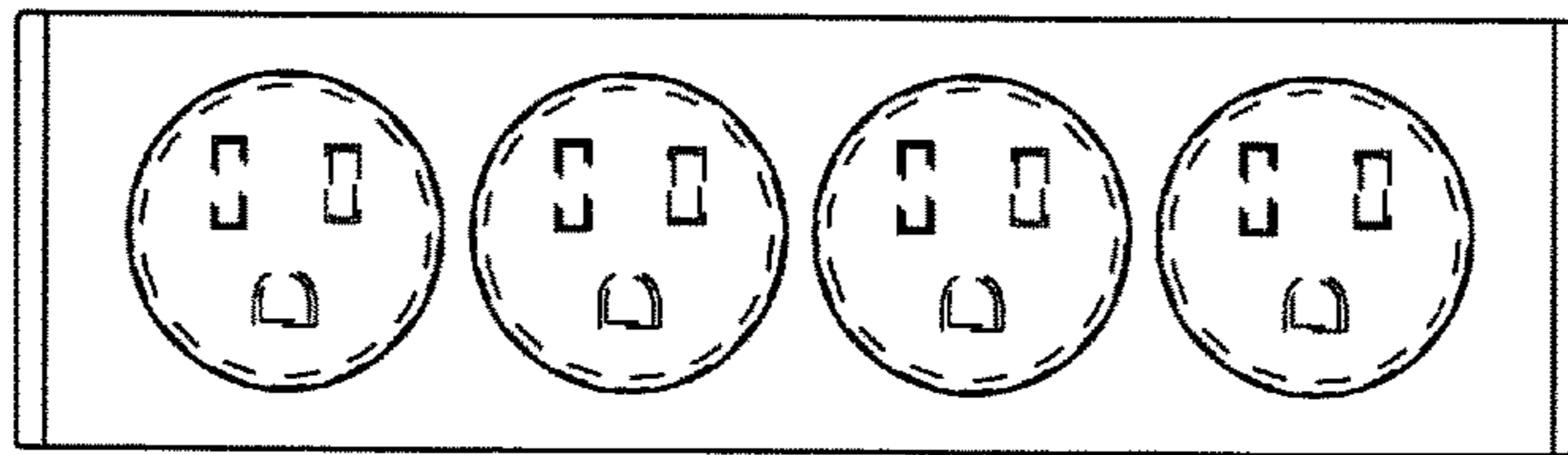

Fig. 11

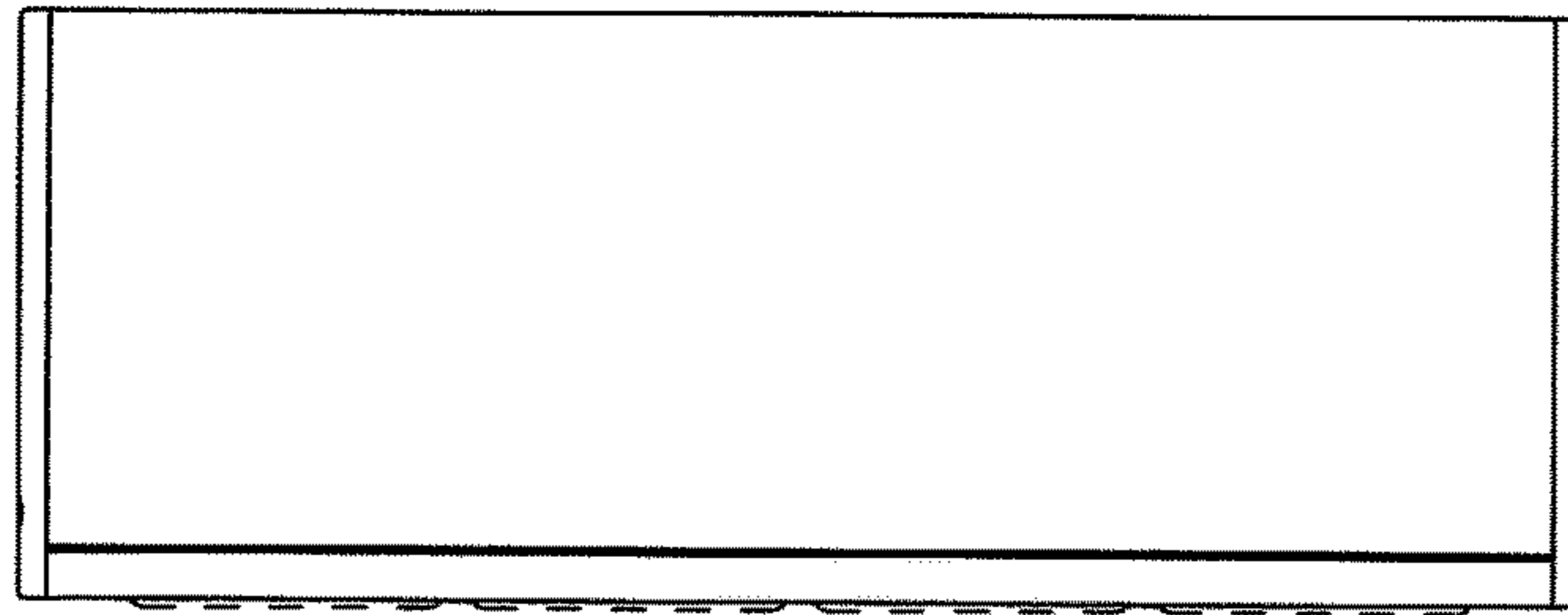

Fig. 12

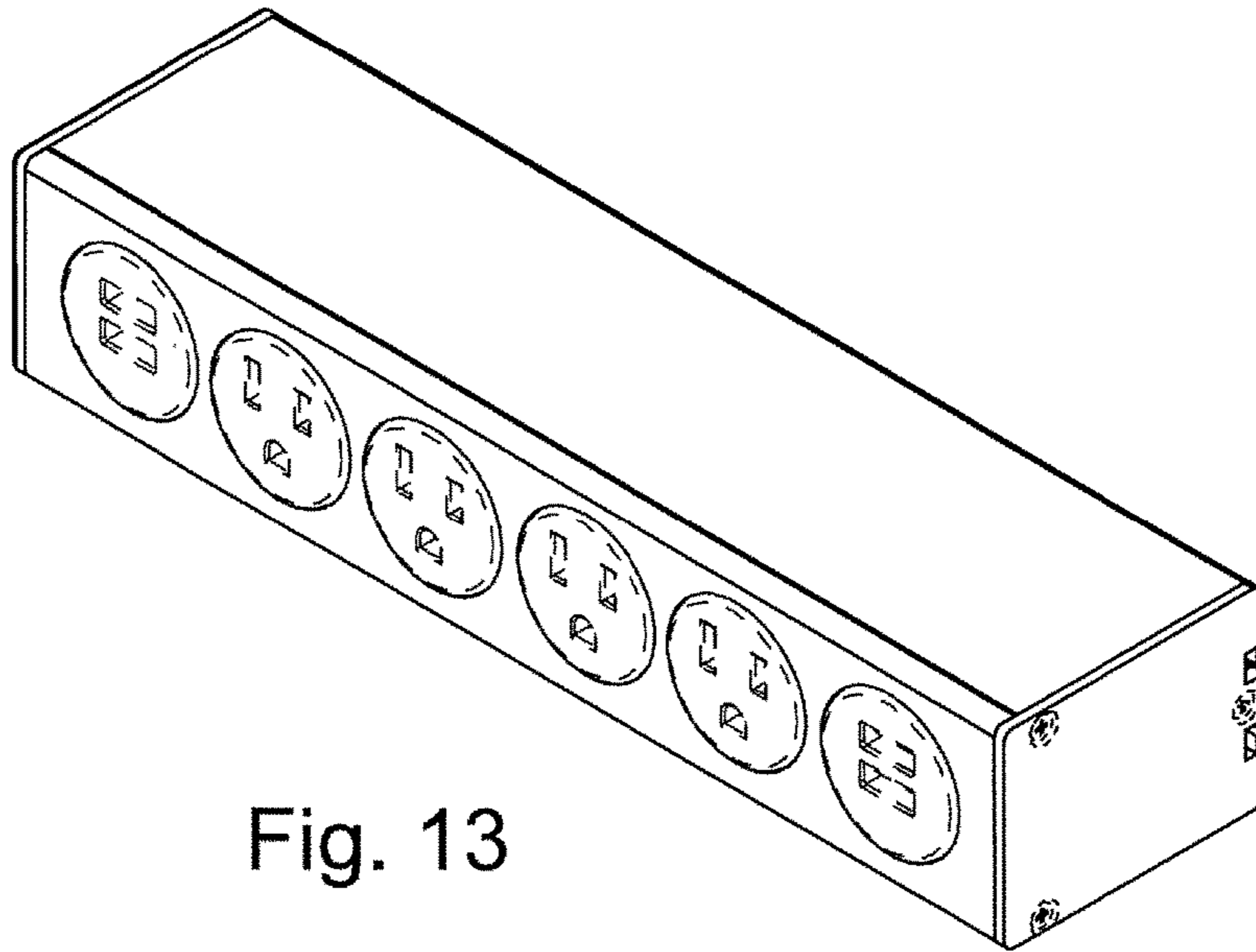

Fig. 13

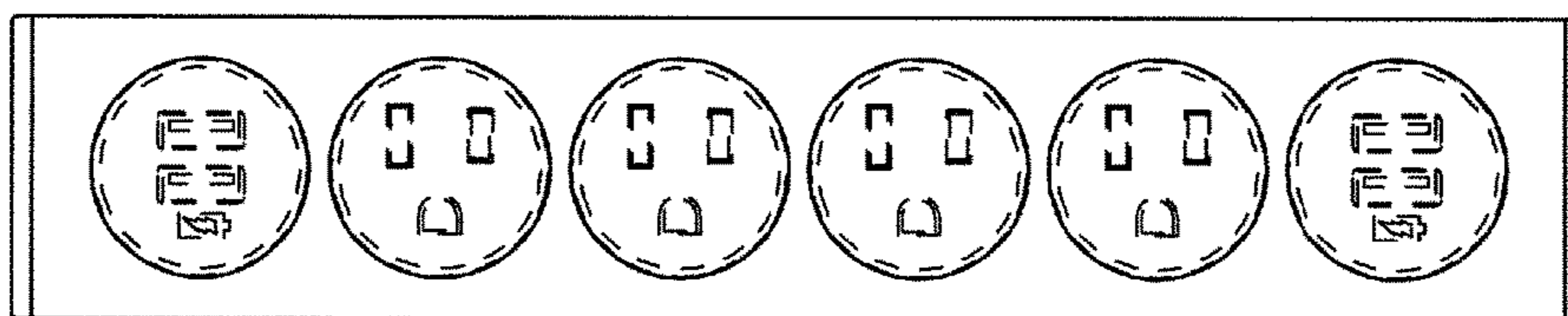

Fig. 14

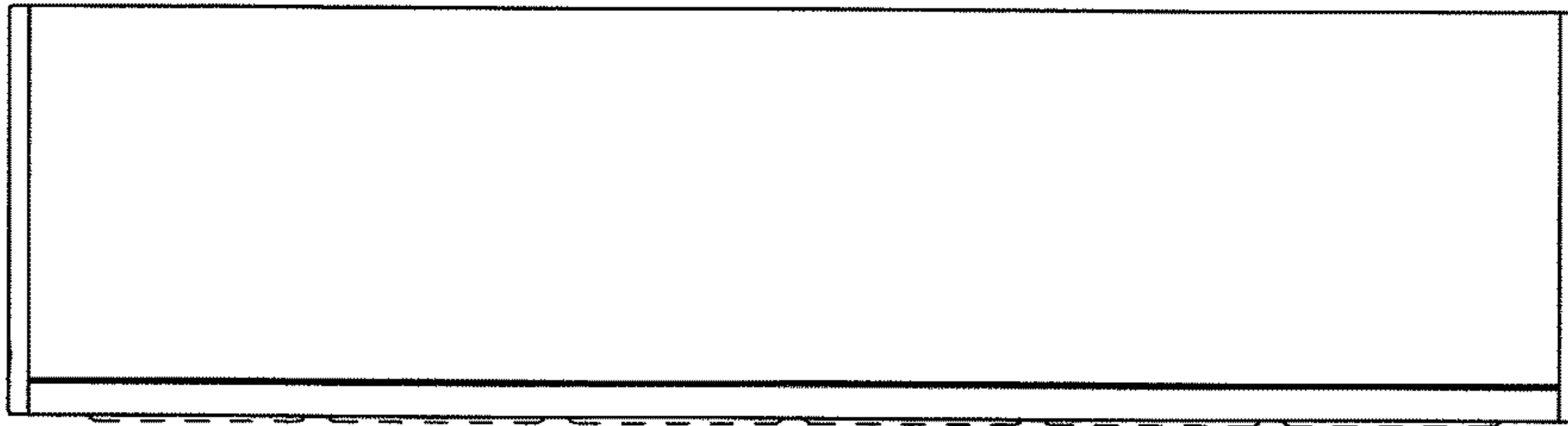

Fig. 15