



US00D815670S

(12) **United States Design Patent**
Terabe et al.

(10) **Patent No.:** **US D815,670 S**
(45) **Date of Patent:** **** Apr. 17, 2018**

(54) **MOLDING SAND INTRODUCING NOZZLE FOR TIGHT-FLASK MOLDING MACHINE**

(71) Applicant: **SINTOKOGIO, LTD.**, Nagoya-shi, Aichi (JP)

(72) Inventors: **Tokiya Terabe**, Toyokawa (JP);
Katsuhito Sato, Toyokawa (JP)

(73) Assignee: **Sintokogio, Ltd.**, Nagoya-shi, Aichi (JP)

(**) Term: **15 Years**

(21) Appl. No.: **29/583,639**

(22) Filed: **Nov. 8, 2016**

(30) **Foreign Application Priority Data**

May 17, 2016 (JP) 2016-010451

(51) **LOC (11) Cl.** **15-03**

(52) **U.S. Cl.**
USPC **D15/135**

(58) **Field of Classification Search**
USPC D15/122, 135, 136, 137, 138, 141, 142,
D15/199, 89, 91; D12/1, 2, 8; D8/313;
D7/339-341, 348-349, 402-404
(Continued)

(56) **References Cited**

U.S. PATENT DOCUMENTS

3,277,739 A 10/1966 Morse
D442,846 S * 5/2001 Bastian D8/313
(Continued)

FOREIGN PATENT DOCUMENTS

TW 343567 U 10/1998
TW D141728 S 8/2011
(Continued)

OTHER PUBLICATIONS

Taiwan Patent Office, Notice of Allowance in counterpart Taiwan Application No. 105306707, dated Aug. 4, 2017.
(Continued)

Primary Examiner — Ian Simmons

Assistant Examiner — Khawaja Anwar

(74) *Attorney, Agent, or Firm* — Leydig Voit & Mayer

(57) **CLAIM**

The ornamental design for a molding sand introducing nozzle for tight-flask molding machine, as shown and described.

DESCRIPTION

FIG. 1 is a front perspective view of a molding sand introducing nozzle for tight-flask molding machine of the present invention.

FIG. 2 is a rear perspective view of the molding sand introducing nozzle for tight-flask molding machine of FIG. 1.

FIG. 3 is a front view of the molding sand introducing nozzle for tight-flask molding machine of FIG. 1.

FIG. 4 is a rear view of the molding sand introducing nozzle for tight-flask molding machine of FIG. 1.

FIG. 5 is a top plan view of the molding sand introducing nozzle for tight-flask molding machine of FIG. 1.

FIG. 6 is a bottom view of the molding sand introducing nozzle for tight-flask molding machine of FIG. 1.

FIG. 7 is a right side view of the molding sand introducing nozzle for tight-flask molding machine of FIG. 1.

FIG. 8 is a left side view of the molding sand introducing nozzle for tight-flask molding machine of FIG. 1.

FIG. 9 is an enlarged sectional view taken along the line 9-9 of the molding sand introducing nozzle for tight-flask molding machine of FIG. 3; and,

FIG. 10 is a reference perspective view of the molding sand introducing nozzle for tight-flask molding machine of FIG. 1 in use, wherein the molding sand introducing nozzle is attached to an upper overlay frame part of a tight-flask molding machine for molding a cast, which is for illustrative purpose only and form no part of the claimed design.

The features shown in broken lines illustrate portions of the molding sand introducing nozzle for tight-flask molding machine and form no part of the claimed design.

1 Claim, 10 Drawing Sheets

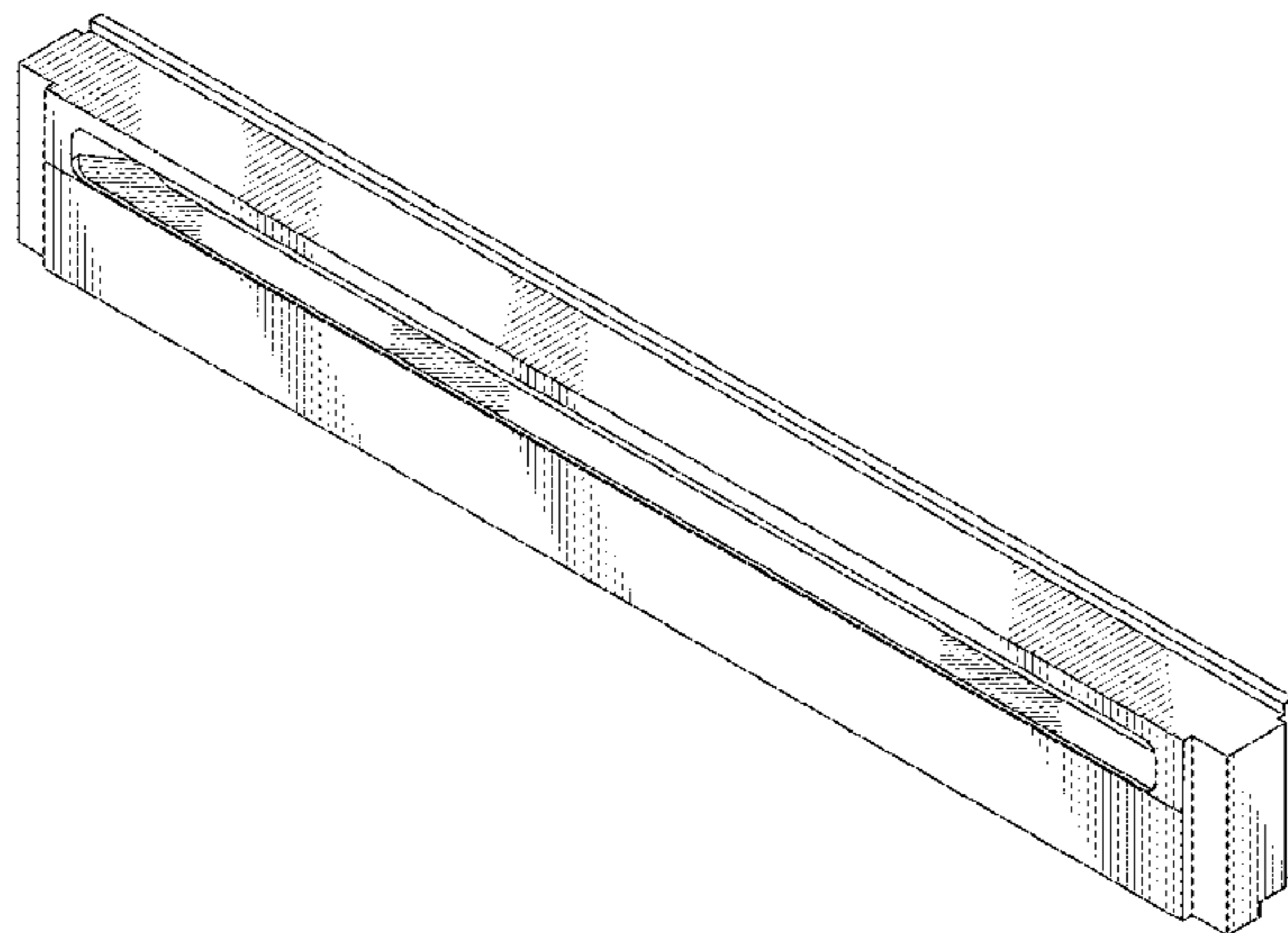

(58) **Field of Classification Search**

CPC B29C 45/0001; B29C 2043/3427; B29C 2043/3494; B29C 2045/0006; B29C 2045/0043; B29C 2045/0049; B29C 2045/14803; B29C 2945/76444; B29C 43/24; B29C 45/0005; B29C 45/0025; B29C 45/006; B29C 45/14778; B29C 45/14811; B29C 45/14819; B29C 45/1657; B29C 45/14311; B29C 45/1671; B29C 45/1761; B29C 45/2708; B29C 45/40; B29C 45/401; B29C 45/42; B29C 45/84; B29C 47/0004; B29C 47/0021

See application file for complete search history.

D749,156 S	2/2016	Sugiura et al.	
D750,980 S	3/2016	Takach et al.	
D755,004 S	5/2016	Bock et al.	
D758,462 S	6/2016	Bell	
D759,840 S	6/2016	Grovender	
D766,696 S	9/2016	Kemker	
D766,844 S	9/2016	Turksu et al.	
D767,364 S *	9/2016	Bertani	D8/313
D768,216 S	10/2016	Funakoshi et al.	
D768,741 S	10/2016	Funakoshi et al.	
D771,162 S *	11/2016	Lee	D15/91
D777,367 S	1/2017	Ma	
D779,977 S	2/2017	Jacob et al.	
D782,727 S	3/2017	Weiss et al.	
D783,422 S	4/2017	Kashimoto	
D793,808 S	8/2017	Weaden et al.	
2008/0303183 A1	12/2008	Rote et al.	
2013/0292481 A1	11/2013	Filson et al.	

(56) **References Cited**

U.S. PATENT DOCUMENTS

D479,884 S	9/2003	Berryman	
6,709,188 B2	3/2004	Ushimaru	
D498,542 S	11/2004	Brushaber	
D499,190 S	11/2004	Garelick et al.	
D506,693 S	6/2005	Kaczmarek	
D527,611 S	9/2006	Sato	
D547,336 S	7/2007	Kai	
D583,213 S *	12/2008	Kubota	D15/89
D604,141 S *	11/2009	Reed	D8/313
D612,364 S	3/2010	Kwolek	
D617,356 S	6/2010	Wang	
D690,331 S	9/2013	Kitamura	
D707,853 S	6/2014	Lafontaine	
D718,574 S *	12/2014	Nordwall	D7/402
D723,715 S	3/2015	Lafontaine	
D729,034 S *	5/2015	Kaishian	D8/313
D733,603 S	7/2015	Graf	
D736,449 S	8/2015	Getty	

FOREIGN PATENT DOCUMENTS

TW	151847 S	2/2013
TW	M459232 U	8/2013

OTHER PUBLICATIONS

Taiwan Patent Office, Notice of Allowance in counterpart Taiwan Application No. 105306709, dated Aug. 4, 2017.
 United States Patent and Trademark Office, Office Action in U.S. Appl. No. 29/583,642, dated Dec. 13, 2017.
 United States Patent and Trademark Office, Office Action in U.S. Appl. No. 29/583,645, dated Nov. 29, 2017.
 United States Patent and Trademark Office, Notice of Allowance in U.S. Appl. No. 29/583,635, dated Oct. 16, 2017.

* cited by examiner

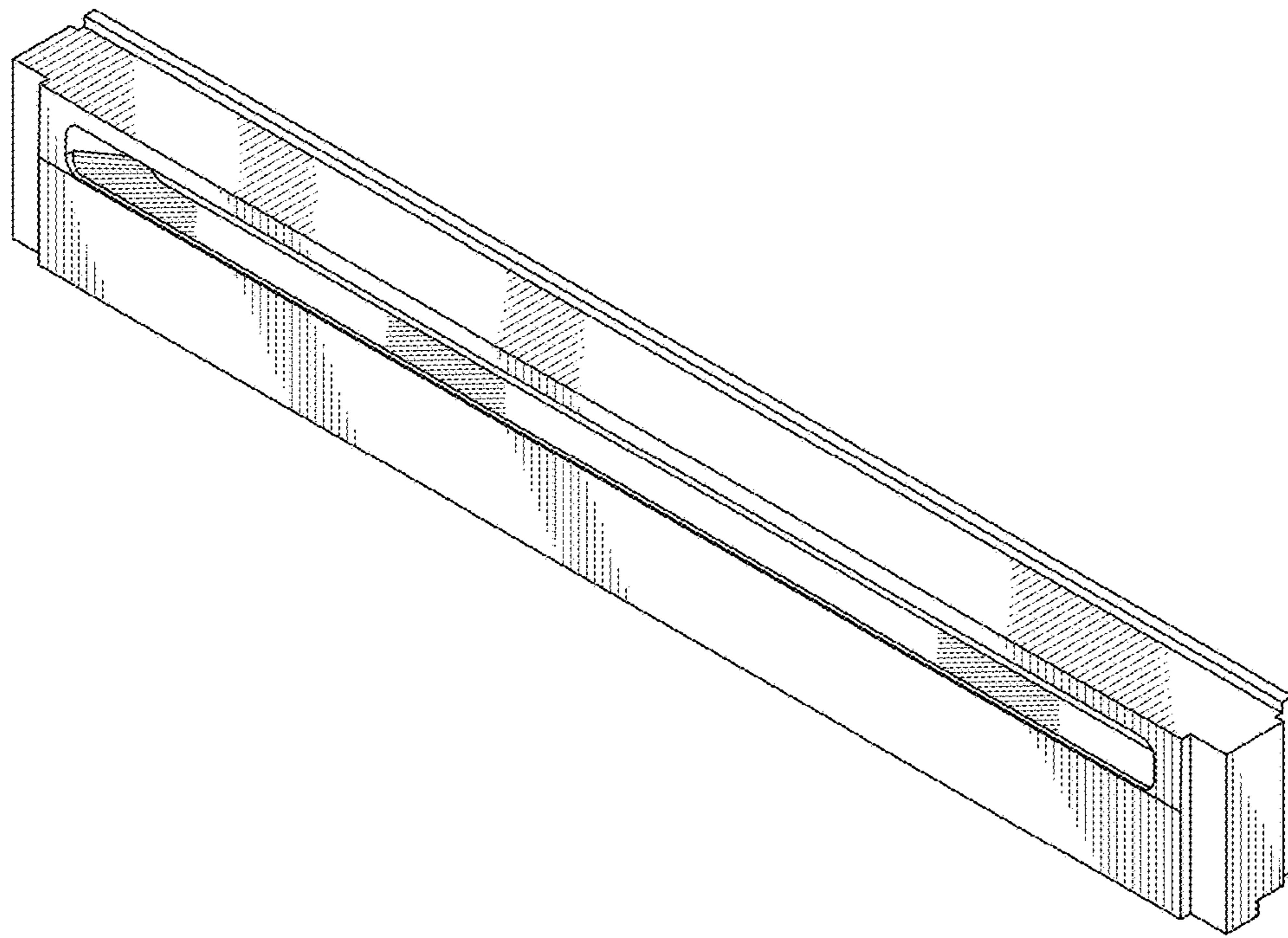

FIG. 1

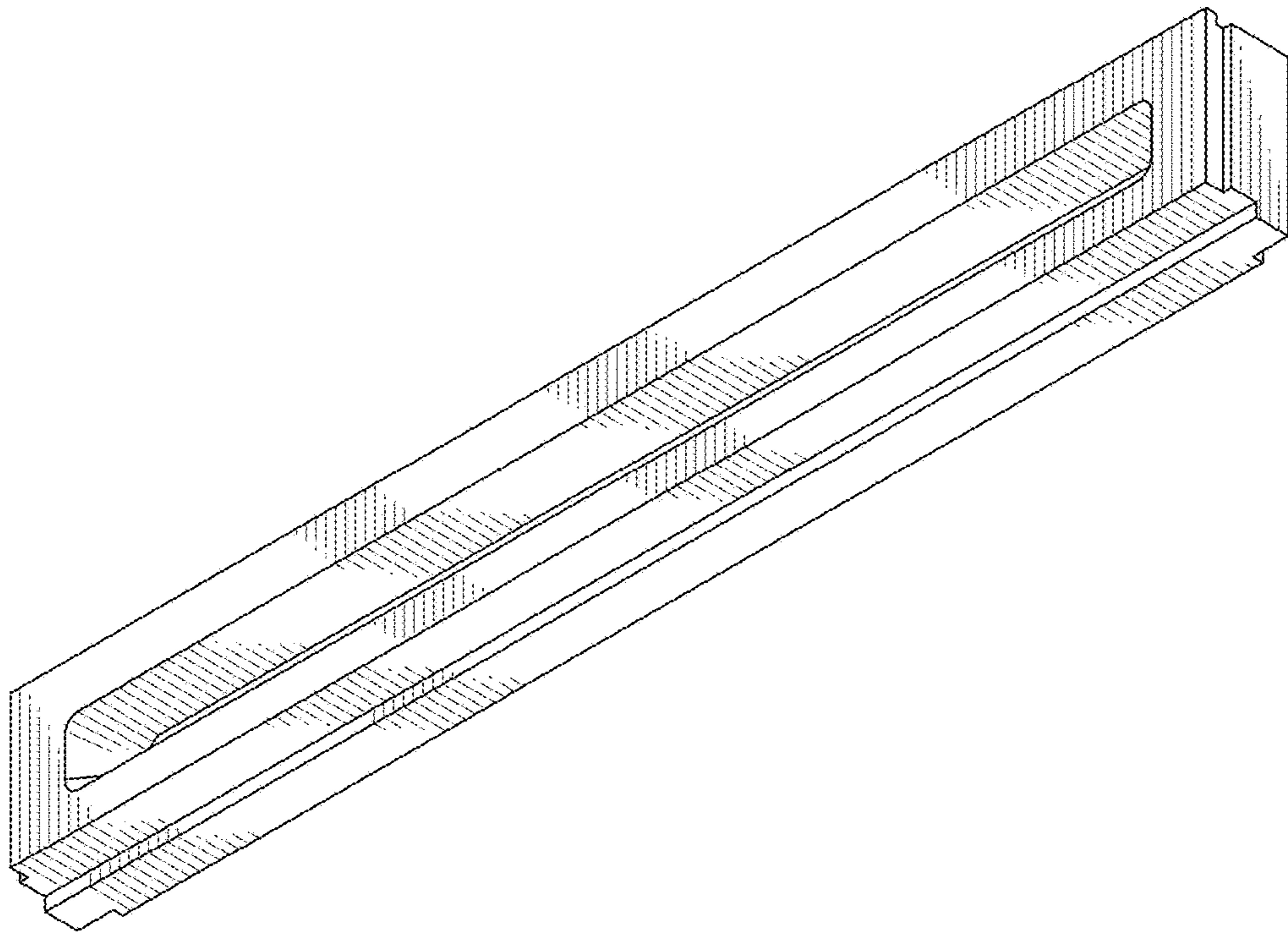

FIG. 2

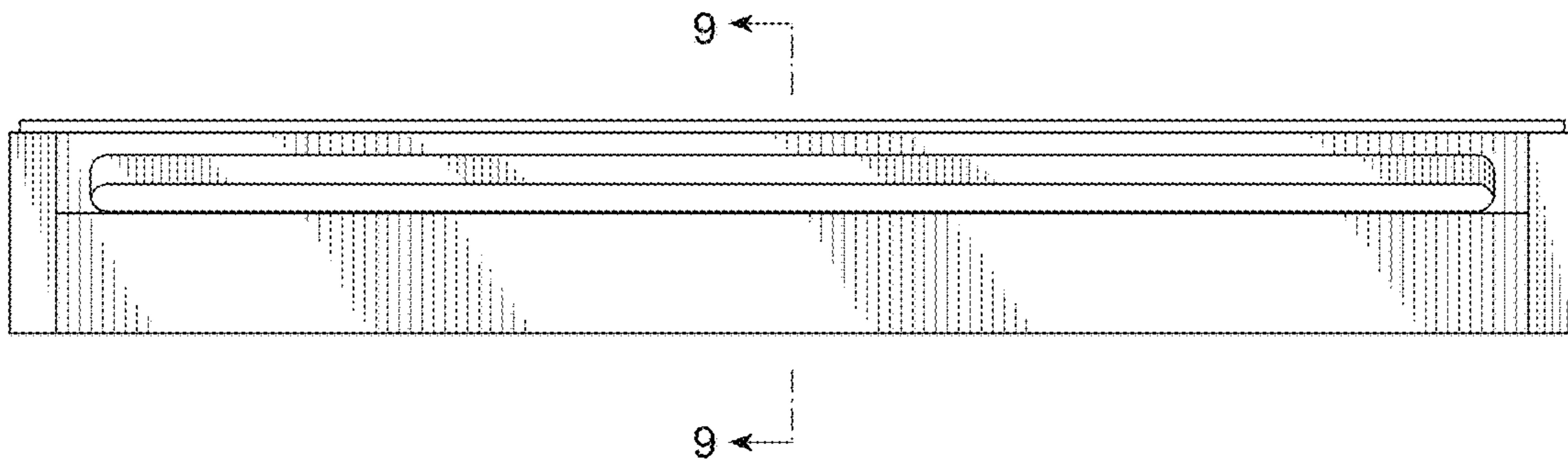

FIG. 3

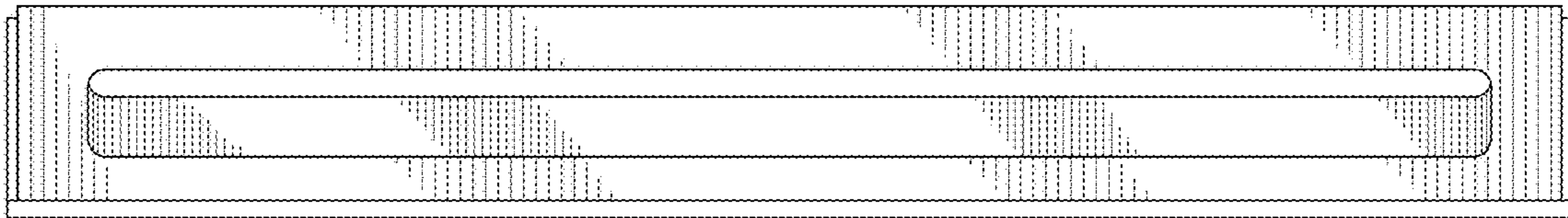

FIG. 4



FIG. 5



FIG. 6

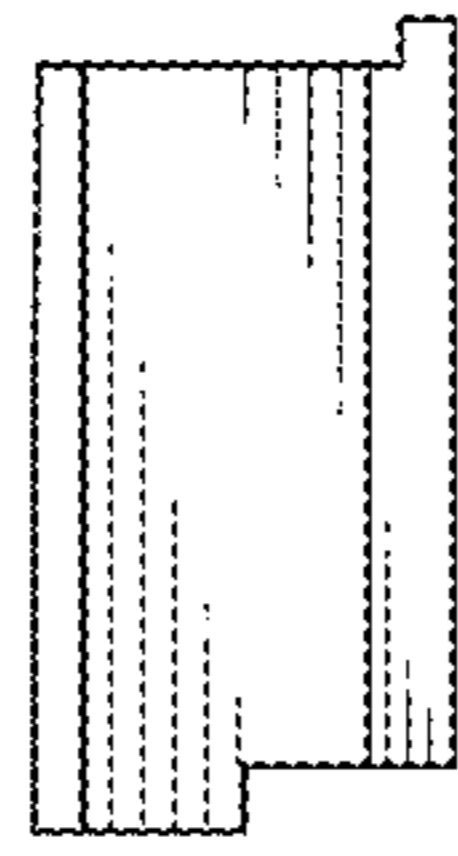

FIG. 7

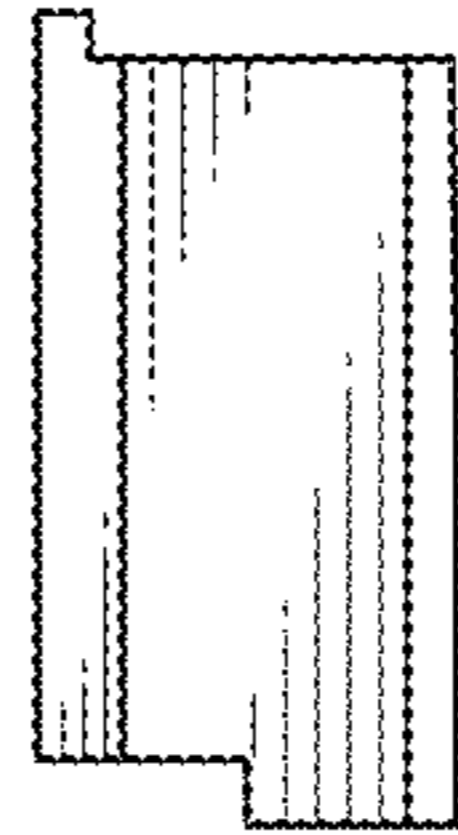

FIG. 8

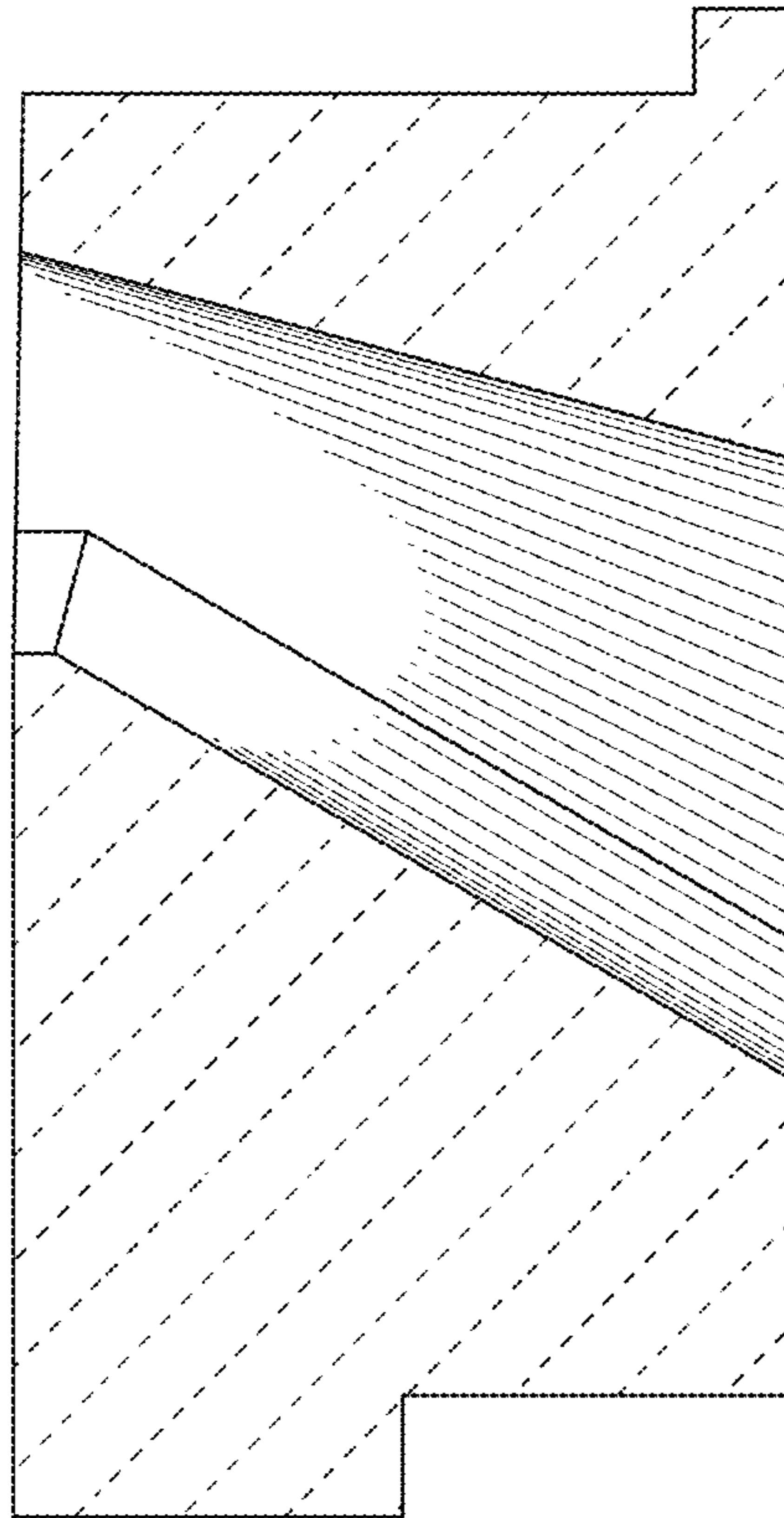

FIG. 9

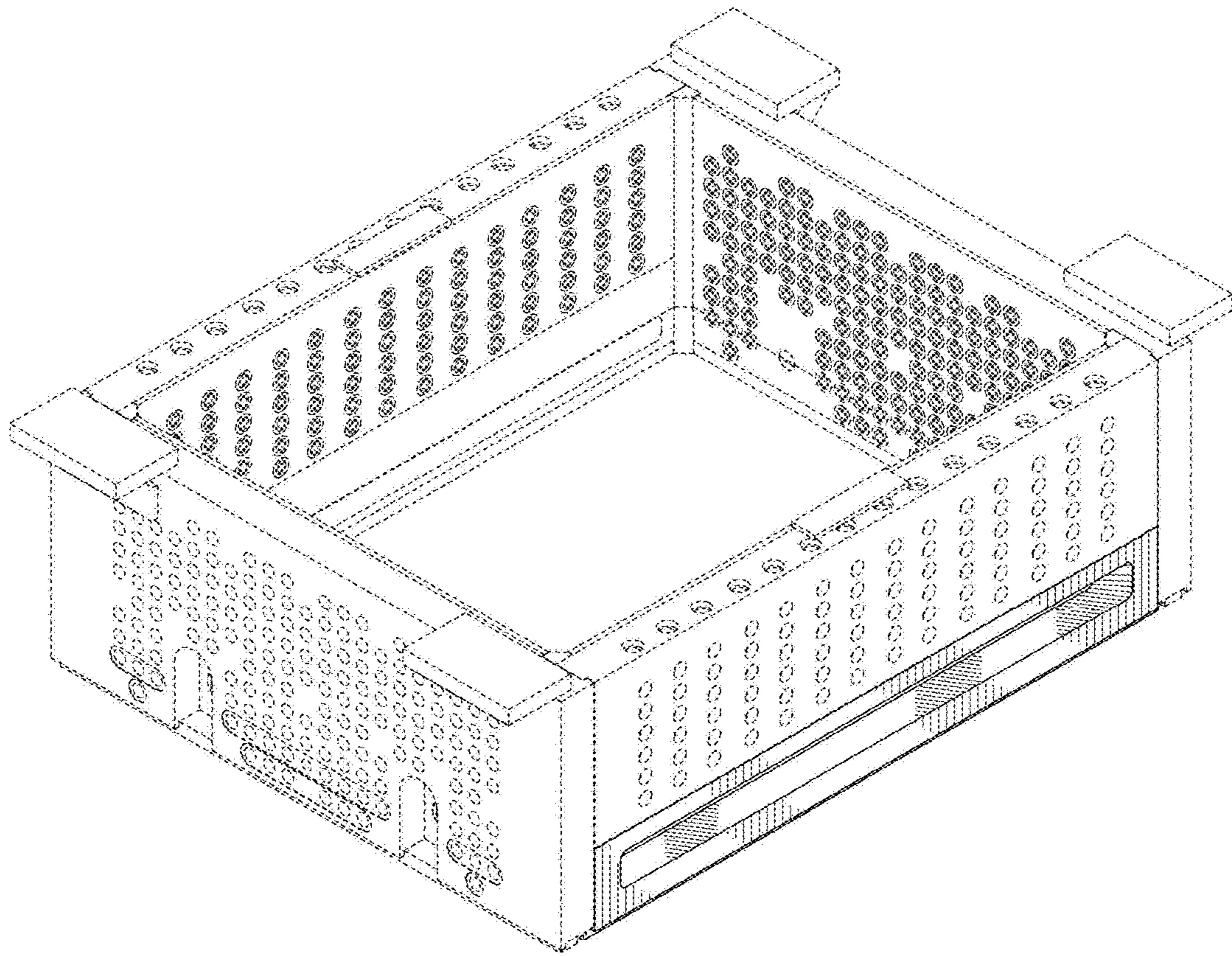

FIG. 10