



US00D815577S

(12) **United States Design Patent**
Chiang

(10) **Patent No.:** **US D815,577 S**

(45) **Date of Patent:** **** Apr. 17, 2018**

- (54) **MIRROR FOR VEHICLE**
- (71) Applicant: **Volvo Lastvagnar AB**, Göteborg (SE)
- (72) Inventor: **Sid Chiang**, Greensboro, NC (US)
- (73) Assignee: **Volvo Lastvagnar AB**, Gothenburg (SE)
- (**) Term: **15 Years**
- (21) Appl. No.: **29/593,302**
- (22) Filed: **Feb. 8, 2017**
- (51) **LOC (11) Cl.** **12-16**
- (52) **U.S. Cl.**
USPC **D12/187**
- (58) **Field of Classification Search**
USPC D12/187, 188, 189; D6/300, 309
CPC B60R 1/08; B60R 1/081; B60R 1/082;
B60R 1/074; B60R 1/076; B60R 1/78;
B60R 1/0605; B60R 1/0617; G02B 5/08;
G02B 7/18; G02B 7/182
See application file for complete search history.

(56) **References Cited**

U.S. PATENT DOCUMENTS

- D285,549 S * 9/1986 Haack D12/187
- D304,710 S * 11/1989 Sharp D12/187
- 4,991,814 A * 2/1991 Schmidt B60R 1/0605
248/479
- D321,163 S * 10/1991 Santo D12/187
- D426,182 S * 6/2000 Brown D12/189

- D545,741 S * 7/2007 Branham D12/187
- D552,020 S * 10/2007 Hofle D12/187
- D575,710 S * 8/2008 Zimmer D12/187
- D580,839 S * 11/2008 Moran D12/187
- D643,354 S * 8/2011 Balicki D12/187
- D702,609 S * 4/2014 Hovind D12/187
- D791,658 S * 7/2017 Ito D12/187
- D798,209 S * 9/2017 Tseng D12/187

OTHER PUBLICATIONS

Images of Mack CXU Pinnacle Truck, released 2006, 2 pages.

* cited by examiner

Primary Examiner — Karen S Acker
Assistant Examiner — Jerry Shiuan-Hua Hsu
(74) *Attorney, Agent, or Firm* — Tucker Ellis LLP

(57) **CLAIM**

The ornamental design for a mirror for vehicle, as shown and described.

DESCRIPTION

FIG. 1 is a front-left-bottom perspective view of a mirror for vehicle showing my new design.
FIG. 2 is a rear-left-top perspective view thereof.
FIG. 3 is a front view thereof.
FIG. 4 is a rear view thereof.
FIG. 5 is a left side view thereof.
FIG. 6 is a right side view thereof.
FIG. 7 is a top view thereof; and,
FIG. 8 is a bottom view thereof.
The broken lines illustrate portions of the mirror for vehicle that form no part of the claimed design.

1 Claim, 4 Drawing Sheets

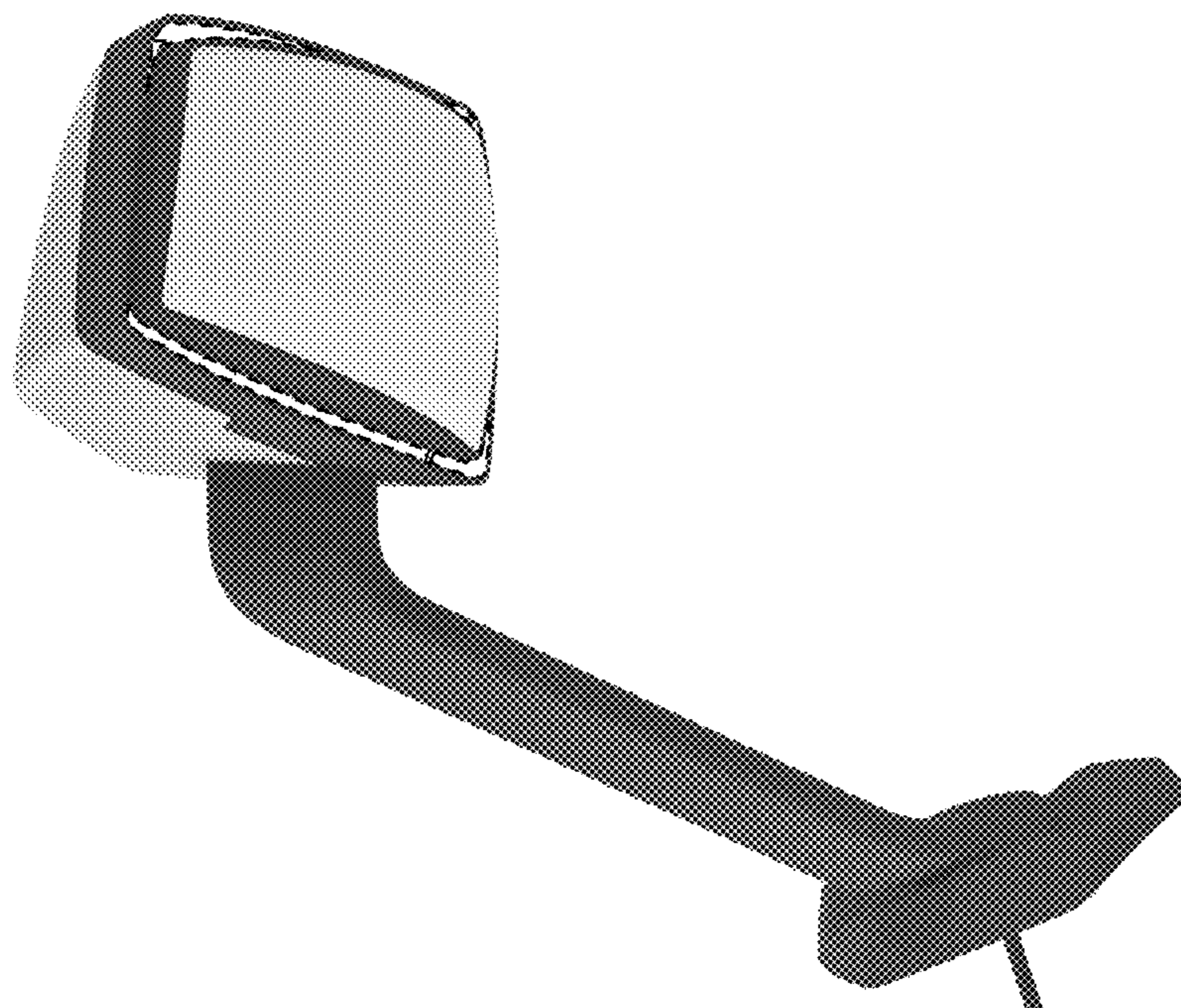

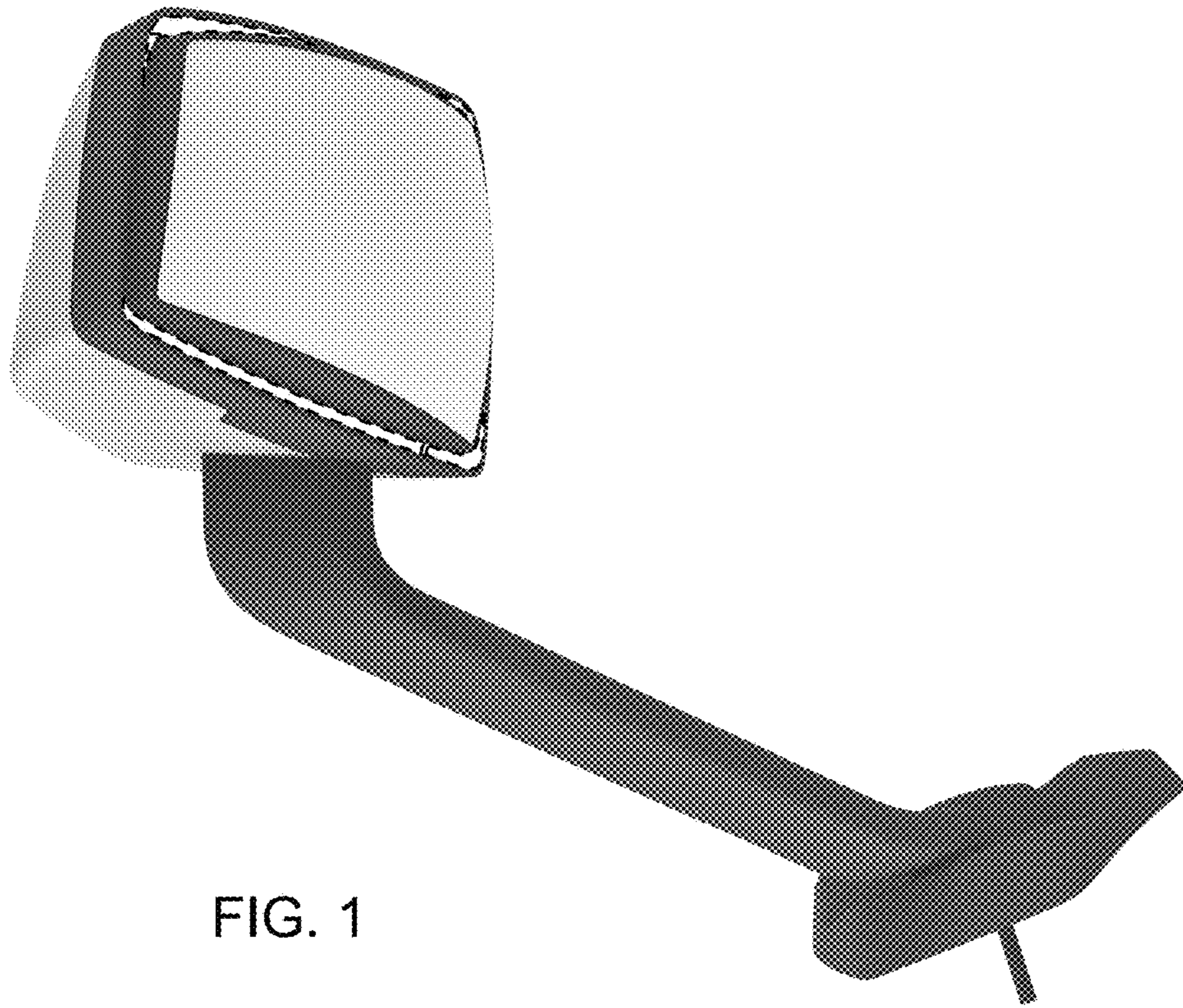

FIG. 1

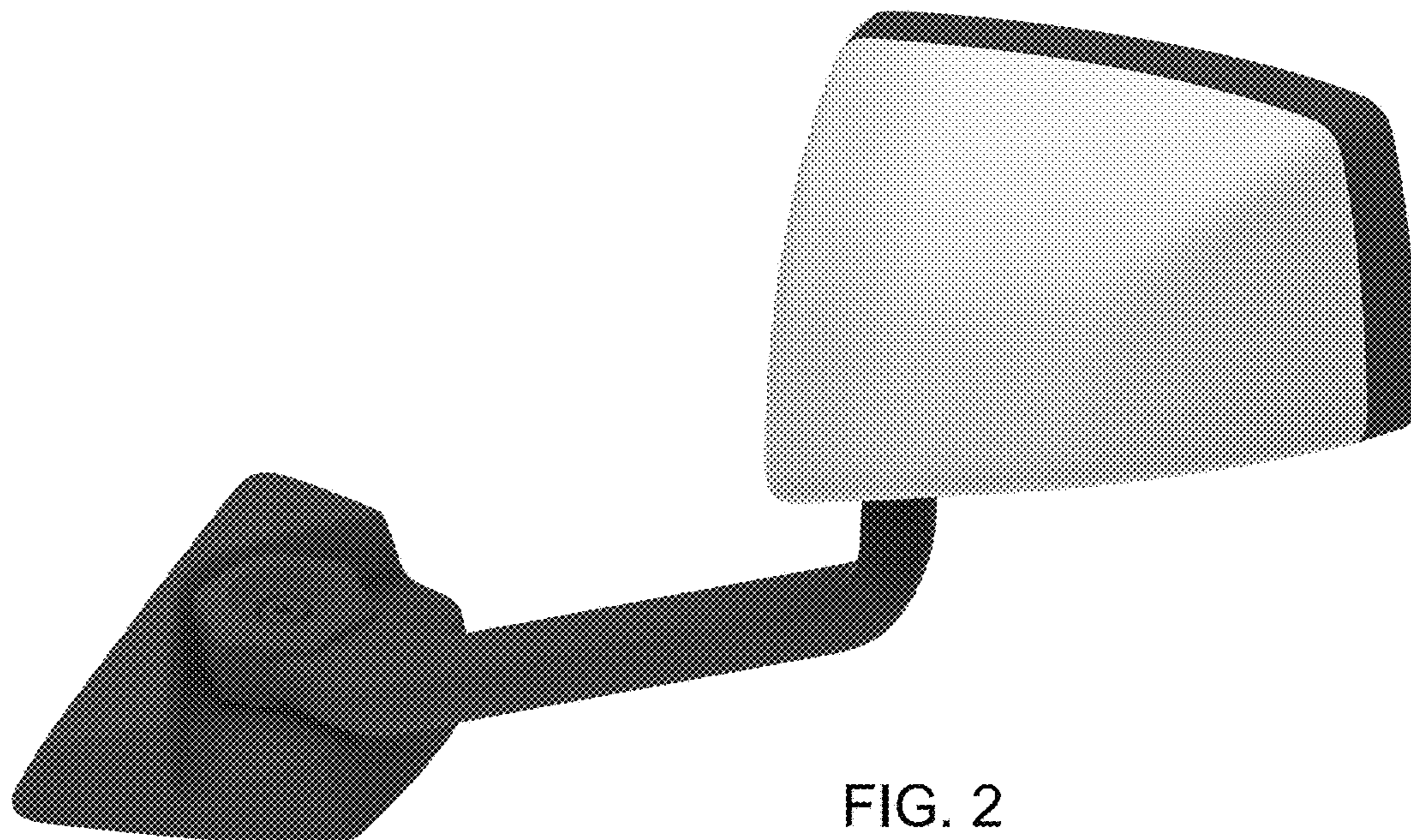

FIG. 2

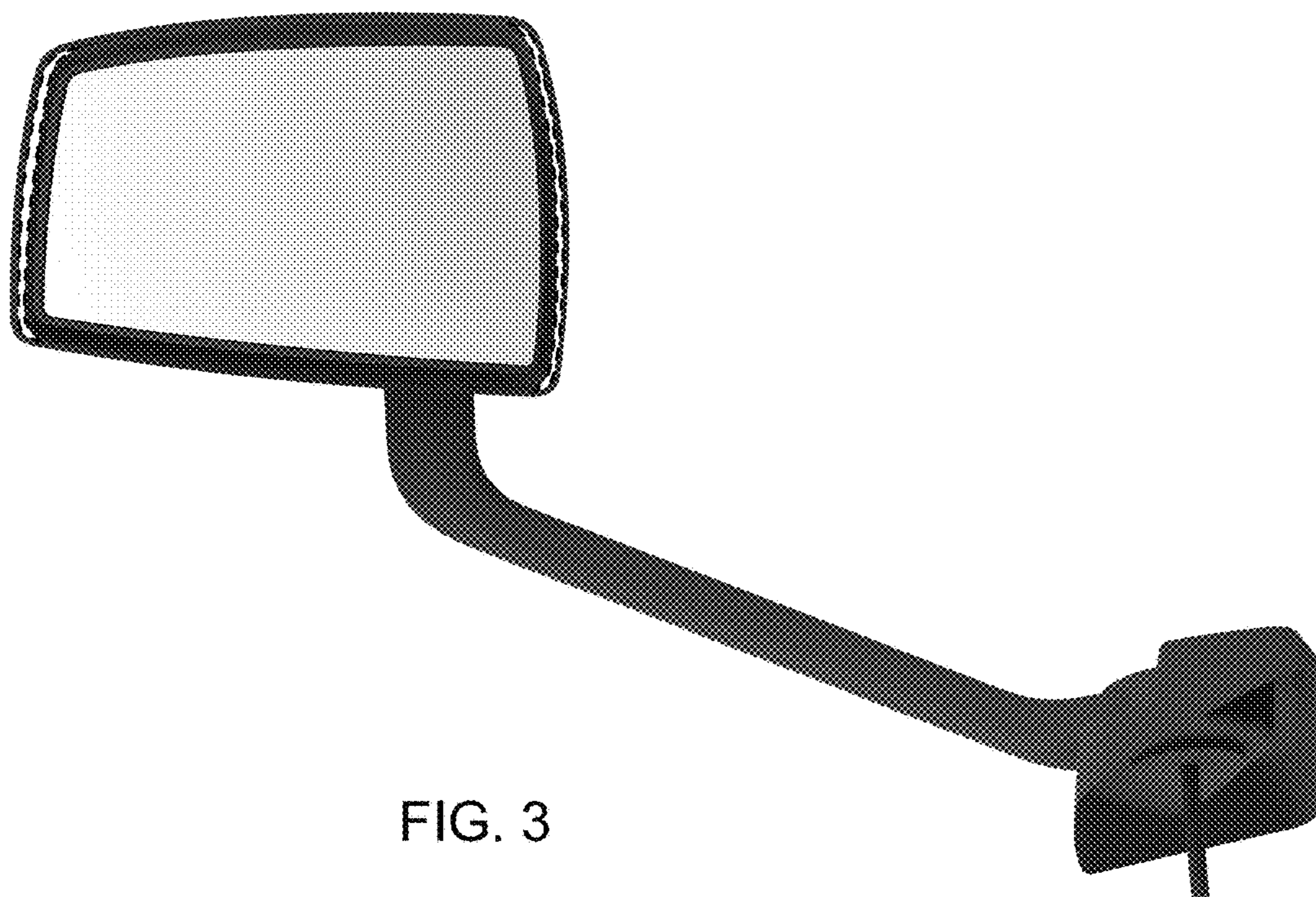

FIG. 3

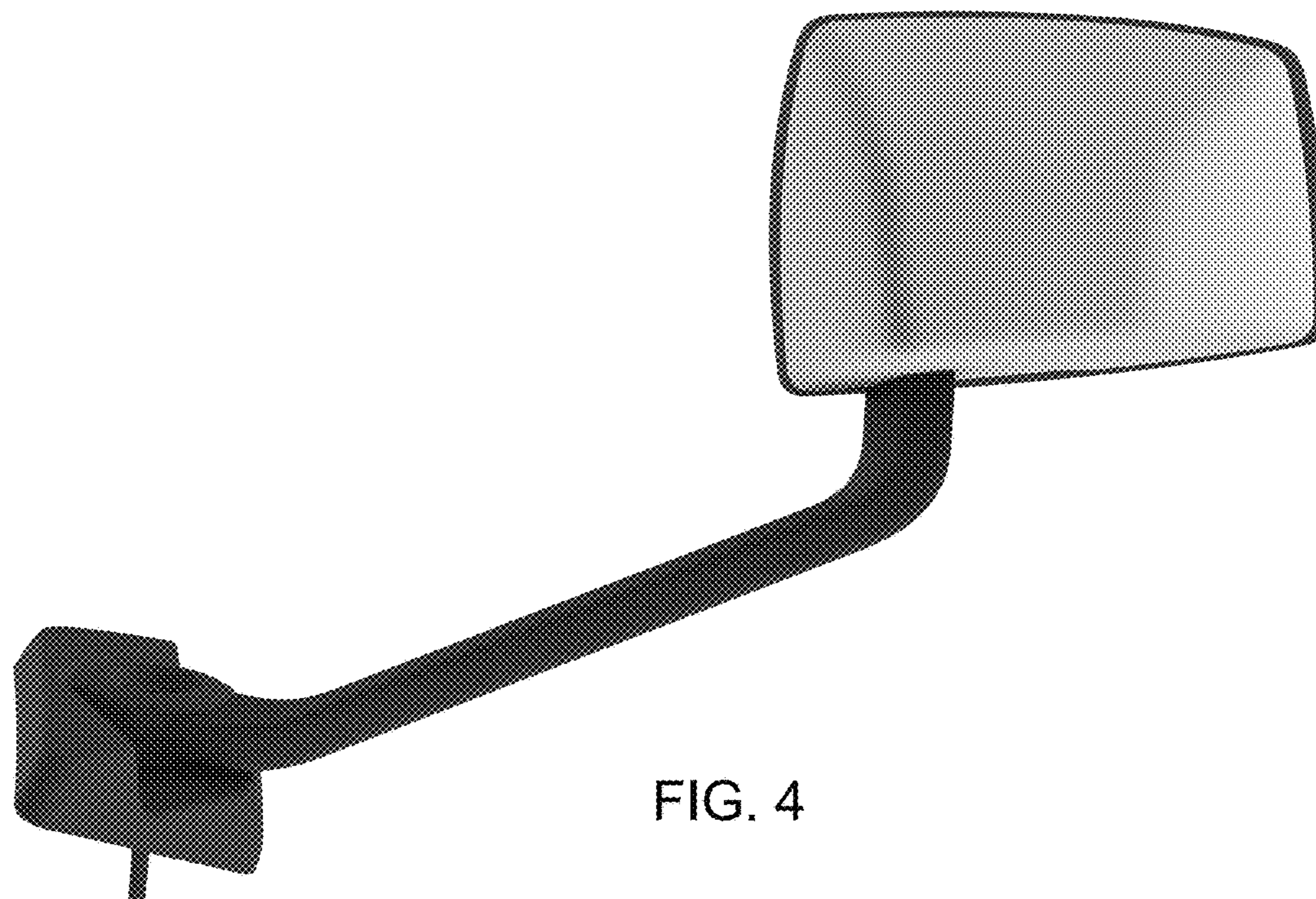

FIG. 4



FIG. 5

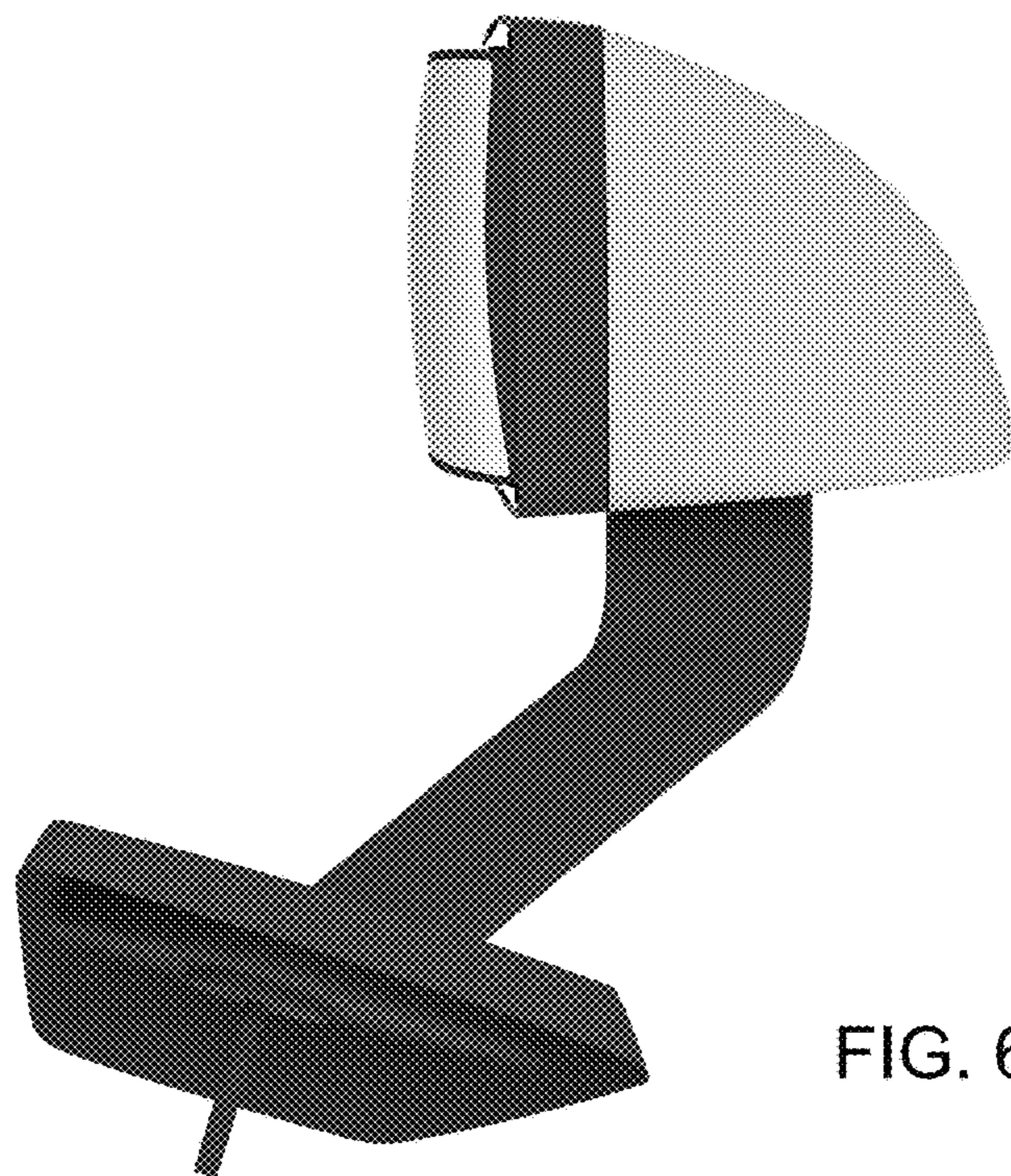

FIG. 6

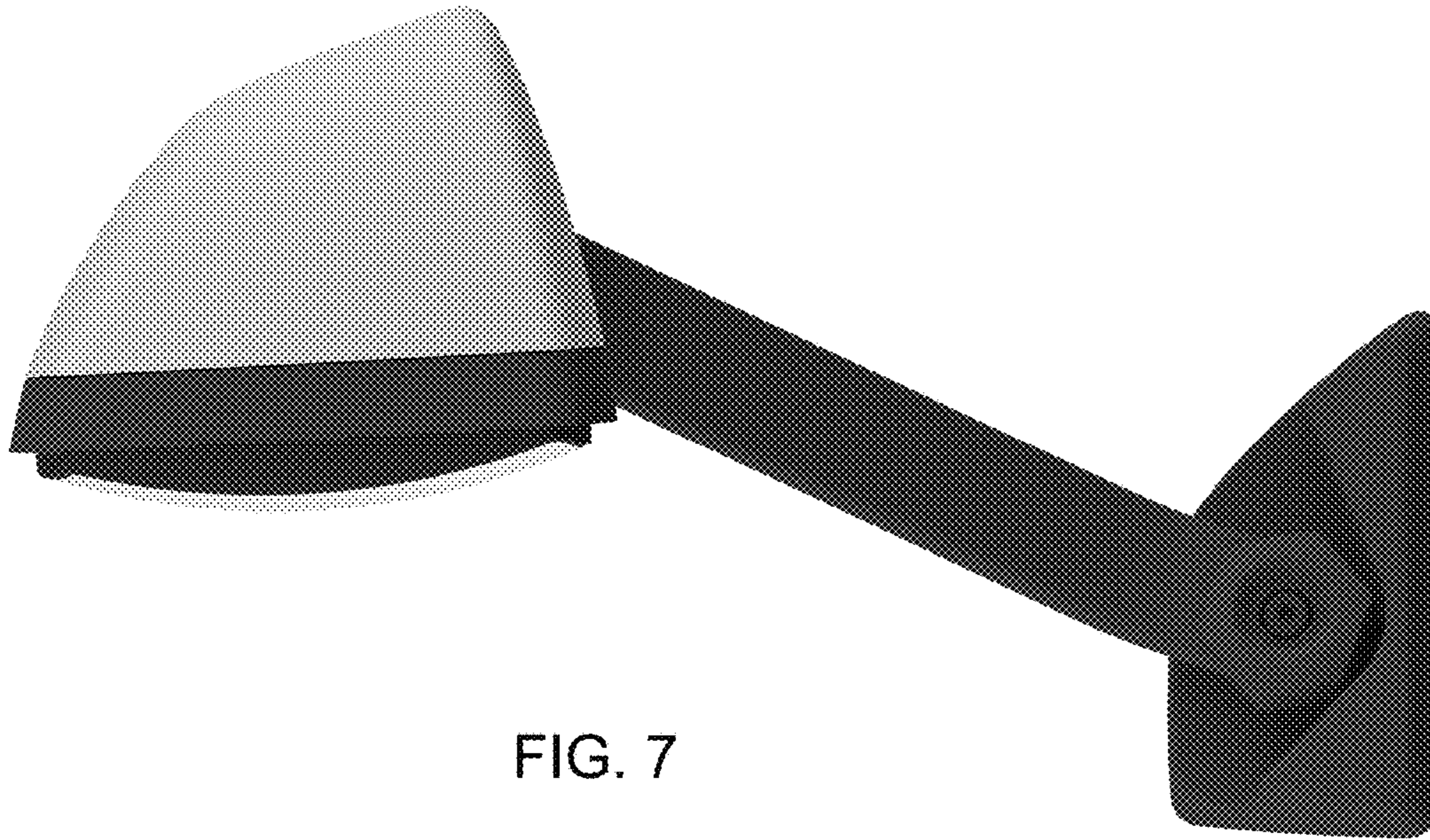

FIG. 7

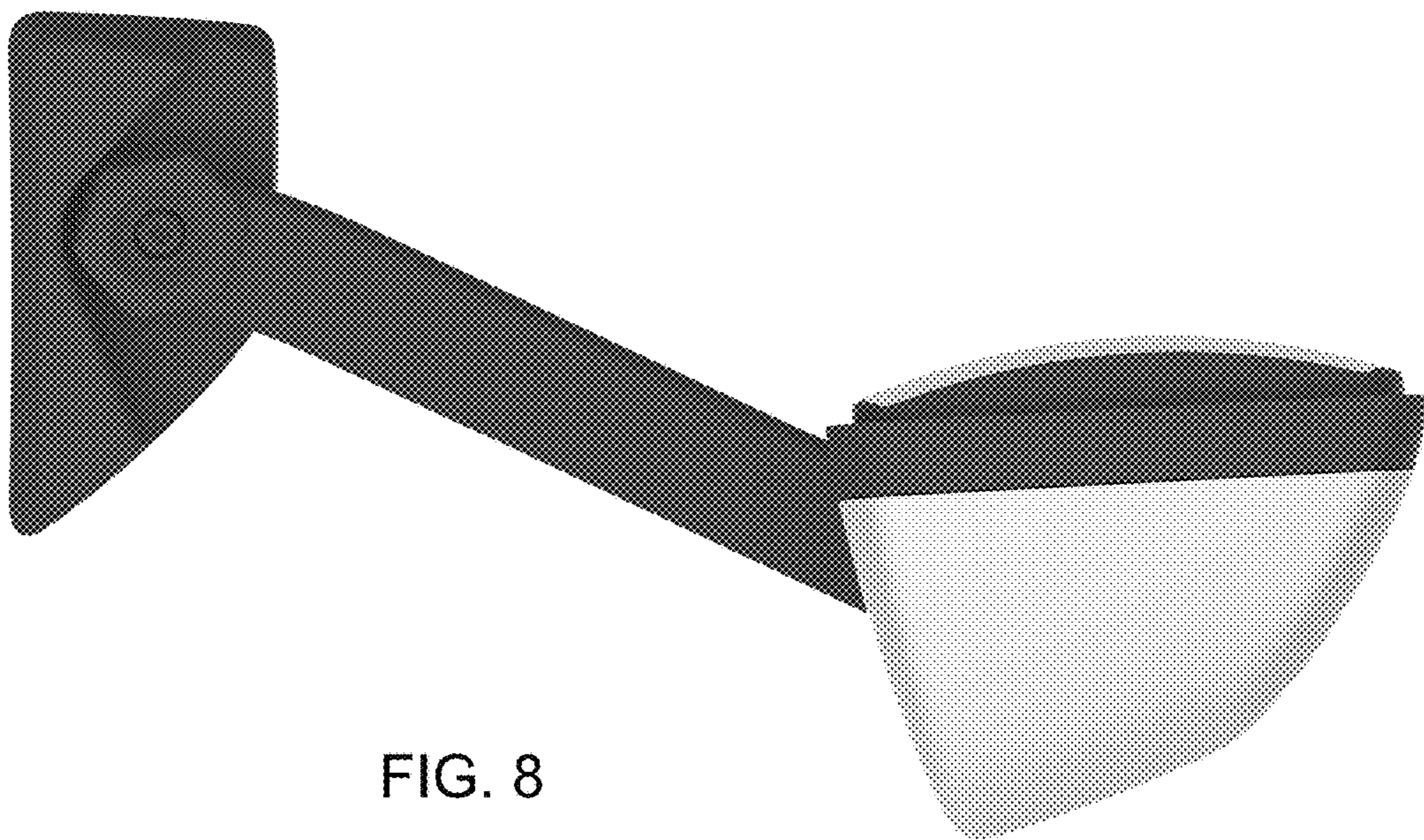

FIG. 8