



US00D814900S

(12) **United States Design Patent** (10) **Patent No.:** **US D814,900 S**
Kaye, Jr. et al. (45) **Date of Patent:** **** Apr. 10, 2018**

(54) **BLADE FOR OSCILLATING POWER TOOLS**

(71) Applicant: **BLACK & DECKER INC.**, New Britain, CT (US)

(72) Inventors: **Thomas R. Kaye, Jr.**, Fallston, MD (US); **Bradley J. Nohr**, Bel Air, MD (US)

(73) Assignee: **Black & Decker Inc.**, New Britain, CT (US)

(**) Term: **15 Years**

(21) Appl. No.: **29/591,013**

(22) Filed: **Jan. 16, 2017**

(51) **LOC (11) Cl.** **08-05**

(52) **U.S. Cl.**
USPC **D8/70; D15/140**

(58) **Field of Classification Search**
USPC **D8/70; D10/64; D15/138, 140; D24/146**

CPC **B23D 61/006; B23D 65/00; B24B 45/006; B26D 7/086; B26D 7/2614; Y10T 83/9457; Y10T 83/9319**

See application file for complete search history.

(56) **References Cited**

U.S. PATENT DOCUMENTS

694,597 A 3/1902 Wood
2,305,465 A 12/1942 Bangser
D137,633 S 4/1944 Jacobsen
2,682,184 A 6/1954 Szarkowski
2,693,365 A 11/1954 Zelewsky
2,766,791 A 10/1956 Givens
2,785,515 A 3/1957 Sansiq
2,997,819 A 8/1961 Schact
3,055,497 A 9/1962 Klonski
3,436,875 A 4/1969 Cheney
3,440,915 A 4/1969 Weyant
3,554,197 A 1/1971 Dobbie
3,656,393 A 4/1972 Goellner
3,905,374 A 9/1975 Winter
3,943,934 A 3/1976 Bent

4,015,371 A 4/1977 Grayston
4,059,930 A 11/1977 Alessio
4,106,181 A 8/1978 Mattchen
4,112,541 A 9/1978 Tetradis
4,252,121 A 2/1981 Arnegger
4,253,776 A 3/1981 Orain
4,265,285 A 5/1981 Fodor
4,386,609 A 6/1983 Mongeon
4,393,626 A 7/1983 Schroer
4,513,742 A 4/1985 Arnegger
4,590,837 A 5/1986 Nanba
4,597,227 A 7/1986 Gentischer et al.
4,599,077 A 7/1986 Vuillard
4,648,735 A 3/1987 Oddenino
4,700,478 A 10/1987 Mezger et al.
4,784,034 A 11/1988 Stones et al.
4,825,091 A 4/1989 Breyer et al.
4,891,884 A 1/1990 Torbet
RE33,335 E 9/1990 Gentischer et al.
4,980,976 A 1/1991 Junginger et al.
4,989,374 A 2/1991 Rudolf et al.
5,027,684 A 7/1991 Neukam
5,022,188 A 8/1991 Borst
5,038,478 A 8/1991 Mezger et al.
5,064,325 A 11/1991 McRoskey
5,085,589 A 2/1992 Kan
5,107,737 A 4/1992 Tagliaferri
5,122,142 A 6/1992 Pascaloff
5,157,873 A 10/1992 Rudolf et al.
5,199,223 A 4/1993 Rudolf et al.
5,219,378 A 6/1993 Arnold
5,235,719 A 8/1993 Wimberley
5,263,283 A 11/1993 Rudolf et al.
5,265,343 A 11/1993 Pascaloff
5,269,784 A 12/1993 Mast
D343,247 S * 1/1994 Walen D24/146
5,303,688 A 4/1994 Chiuminatta et al.
5,306,025 A 4/1994 Langhoff
5,306,285 A 4/1994 Miller et al.
5,309,805 A 5/1994 Mezger et al.
5,352,229 A 10/1994 Goble et al.
5,366,312 A 11/1994 Raines
5,382,249 A * 1/1995 Fletcher B23D 51/10
606/176
5,423,825 A 6/1995 Levine
5,423,845 A * 6/1995 McDaniel B23D 61/121
30/355
5,435,063 A 7/1995 Russo
D360,946 S * 8/1995 Goris D24/146
5,440,811 A 8/1995 Challis
D362,065 S * 9/1995 Goris D24/146
5,468,176 A 11/1995 Udert et al.
5,468,247 A 11/1995 Matthai et al.

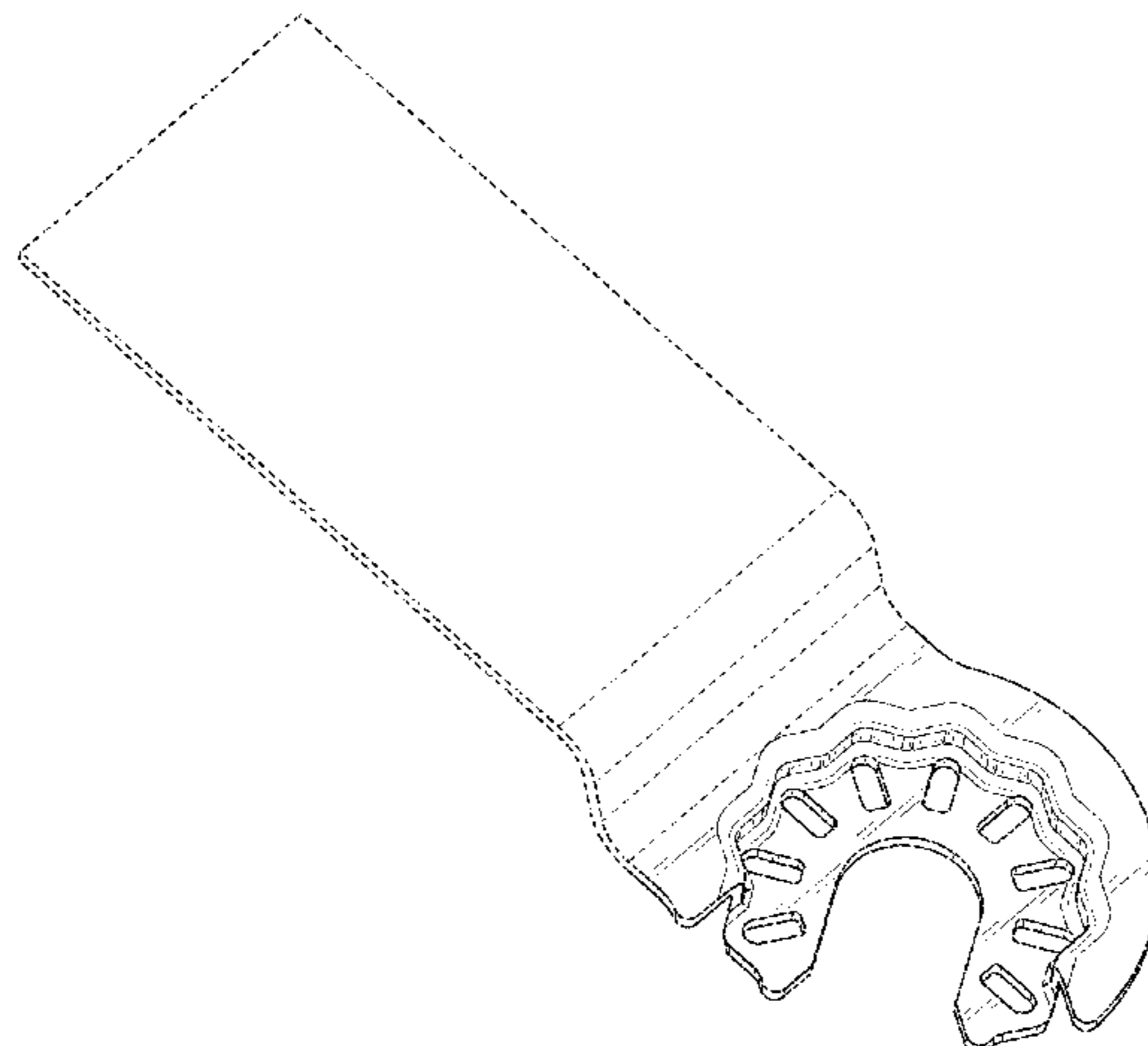

US D814,900 S

5,480,507 A	1/1996	Arnold		7,207,873 B2	4/2007	Hesse et al.	
5,489,285 A	2/1996	Goris		7,217,177 B2	5/2007	Frech et al.	
5,496,316 A	3/1996	Goris		D544,007 S	6/2007	Marasco	
D368,777 S	4/1996	Goble et al.		7,225,714 B2	6/2007	Rompel et al.	
5,507,763 A	4/1996	Petersen et al.		7,237,988 B2	7/2007	Steadings et al.	
D374,286 S	10/1996	Goble et al.		7,258,351 B2	8/2007	Hoffmann et al.	
D374,287 S	10/1996	Goble et al.		7,258,515 B2	8/2007	Krondorfer	
D374,482 S	10/1996	Goble et al.		7,328,752 B2	2/2008	Gass et al.	
5,658,304 A	8/1997	Lim		7,334,511 B2	2/2008	Hesselberg et al.	
5,676,680 A	10/1997	Lim		D563,186 S	3/2008	Ahn	
5,694,693 A	12/1997	Hutchins et al.		7,344,435 B2	3/2008	Pollak et al.	
5,702,415 A	12/1997	Matthai et al.		7,447,565 B2	11/2008	Cerwin	
5,729,904 A	3/1998	Trott		7,478,979 B2	1/2009	Zhou et al.	
5,735,866 A	4/1998	Adams et al.		7,481,608 B2	1/2009	Zhou et al.	
D394,315 S *	5/1998	Fisher	A61B 17/14 D24/146	7,497,860 B2	3/2009	Carusillo et al.	
				7,527,628 B2 *	5/2009	Fletcher	B23D 51/10 606/177
5,785,571 A	7/1998	Camp					
5,829,931 A	11/1998	Doumani		7,533,470 B2	5/2009	Nottingham et al.	
5,839,196 A	11/1998	Trott		7,537,065 B2	5/2009	Gallagher et al.	
5,848,473 A	12/1998	Brandenburg, Jr.		7,540,334 B2	6/2009	Gass et al.	
D404,485 S *	1/1999	Hutchins	D24/146	7,690,871 B2	4/2010	Steadings et al.	
5,857,237 A	1/1999	Dranginis		7,699,566 B2	4/2010	Nickels, Jr. et al.	
D405,177 S *	2/1999	Hutchins	D24/146	7,717,191 B2	5/2010	Trautner	
D406,223 S	3/1999	Tran		7,717,192 B2	5/2010	Schroeder et al.	
5,957,469 A	9/1999	Miles et al.		7,726,917 B2	6/2010	Mack	
6,022,353 A *	2/2000	Fletcher	B23D 51/10 606/79	7,735,575 B2	6/2010	Trautner	
				7,746,448 B2	6/2010	Franitza et al.	
6,073,939 A	6/2000	Steadings et al.		D619,152 S	7/2010	Evatt et al.	
6,082,515 A	7/2000	Oono et al.		7,753,381 B2	7/2010	Nickels, Jr. et al.	
6,099,397 A	8/2000	Wurst		7,762,349 B2	7/2010	Trautner et al.	
6,116,996 A	9/2000	Yanase		7,784,166 B2	8/2010	Tanner	
6,132,282 A	10/2000	Camp		D623,034 S	9/2010	Evatt et al.	
6,132,300 A	10/2000	Martin		7,798,245 B2	9/2010	Trautner	
6,179,301 B1	1/2001	Steadings et al.		7,833,241 B2	11/2010	Gant	
6,196,554 B1	3/2001	Gaddis et al.		7,841,601 B2	11/2010	Mack	
6,241,259 B1	6/2001	Gaddis et al.		7,854,274 B2	12/2010	Trautner et al.	
6,340,022 B1	1/2002	Schroer		D633,769 S	3/2011	Evatt et al.	
D455,490 S *	4/2002	Pascaloff	D24/146	D633,928 S	3/2011	Nilsson et al.	
D459,805 S *	7/2002	Pascaloff	D24/146	7,901,424 B2	3/2011	Fletcher et al.	
6,430,465 B2	8/2002	Cutler		7,950,152 B2	5/2011	Gallego	
6,434,835 B1	8/2002	Grunikiewicz et al.		7,976,253 B2	7/2011	Steadings et al.	
6,435,521 B2	8/2002	Steadings et al.		7,987,920 B2	8/2011	Schroeder et al.	
D462,766 S	9/2002	Jacobs et al.		7,997,586 B2 *	8/2011	Ziegler	B24B 23/04 279/7
6,488,287 B2	12/2002	Gaddis et al.					
6,499,381 B2	12/2002	Ladish et al.		D646,539 S	10/2011	Maras	
6,503,253 B1 *	1/2003	Fletcher	B23D 51/10 606/79	D646,540 S	10/2011	Maras	
				D646,542 S	10/2011	Wackwitz	
6,536,536 B1	3/2003	Gass et al.		8,038,156 B2	10/2011	Nickels, Jr. et al.	
6,569,001 B2	5/2003	Rudolf et al.		D648,762 S	11/2011	Mack	
6,629,484 B2	10/2003	Soyama et al.		8,047,100 B2	11/2011	King	
6,678,062 B2	1/2004	Haugen et al.		D651,062 S *	12/2011	Wackwitz	D8/70
6,705,807 B1	3/2004	Rudolph et al.		8,070,168 B2	12/2011	Mack	
6,723,101 B2	4/2004	Fletcher et al.		8,082,671 B2	12/2011	Saegesser	
D489,823 S *	5/2004	Fisher	D24/146	D651,499 S *	1/2012	Tong	D8/70
6,747,745 B2	6/2004	Ishikawa et al.		D651,874 S *	1/2012	Davidian	D10/64
6,796,888 B2 *	9/2004	Jasch	B23B 31/008 451/342	D651,875 S *	1/2012	Davidian	D10/64
				D651,876 S *	1/2012	Davidian	D10/64
6,802,764 B2	10/2004	Besch		D651,877 S *	1/2012	Davidian	D10/64
6,832,764 B2	12/2004	Steadings et al.		D651,878 S *	1/2012	Davidian	D10/64
6,834,730 B2	12/2004	Gass et al.		D652,274 S *	1/2012	Davidian	D10/64
6,865,813 B2	3/2005	Pollak		D653,523 S *	2/2012	Wackwitz	D15/138
6,869,346 B2	3/2005	Wendt et al.		8,109,343 B2	2/2012	Schroeder et al.	
6,896,679 B2 *	5/2005	Danger	A61B 17/142 606/178	8,113,520 B2 *	2/2012	Zaiser	B24B 23/04 279/128
6,945,862 B2	9/2005	Jasch et al.		8,151,679 B2	4/2012	Bohne	
6,949,110 B2	9/2005	Ark et al.		D665,242 S	8/2012	Wackwitz	
6,968,933 B2	11/2005	Buckhouse et al.		D669,754 S *	10/2012	Wackwitz	D8/70
7,001,403 B2	2/2006	Hausmann et al.		D681,082 S *	4/2013	Neal, Jr.	D15/139
7,015,445 B2	3/2006	Bishop		D682,651 S	5/2013	McRoberts et al.	
D525,707 S *	7/2006	Kullmer	D24/146	D682,652 S	5/2013	McRoberts et al.	
7,077,735 B2	7/2006	Krondorfer et al.		D693,193 S *	11/2013	Bozic	D8/20
7,093,668 B2	8/2006	Gass et al.		D694,077 S *	11/2013	Bozic	D8/20
7,107,691 B2	9/2006	Nottingham et al.		D694,596 S	12/2013	Davidian et al.	
7,115,027 B2	10/2006	Thomaschewski		D694,597 S	12/2013	Davidian et al.	
7,121,358 B2	10/2006	Gass et al.		D694,598 S	12/2013	Davidian et al.	
7,128,503 B2	10/2006	Steadings et al.		D706,595 S	6/2014	Kaye et al.	
7,169,025 B2	1/2007	Schumacher		8,915,499 B2	12/2014	Kaye et al.	
7,175,625 B2	2/2007	Culbert		8,925,931 B2	1/2015	Sergiyenko et al.	
7,189,239 B2	3/2007	Fisher et al.		9,073,195 B2	7/2015	Kaye, Jr. et al.	

US D814,900 S

D741,136	S *	10/2015	Yang	D15/140	2011/0309589	A1*	12/2011	Maras	B25F 3/00
9,186,770	B2	11/2015	Montplaisir et al.						279/143
9,242,361	B2	1/2016	Kaye, Jr. et al.		2011/0315414	A1	12/2011	Kuntner et al.	
D750,461	S *	3/2016	McRoberts	D8/70	2011/0316241	A1*	12/2011	Zhang	B23D 61/006
D790,942	S *	7/2017	Turner	D8/61					279/143
2001/0041524	A1	11/2001	Steiger et al.		2011/0316242	A1*	12/2011	Zhang	B27B 5/32
2002/0070037	A1	6/2002	Jasch						279/143
2002/0104421	A1	8/2002	Wurst		2012/0025476	A1	2/2012	Nickels, Jr. et al.	
2002/0116023	A1	8/2002	Fletcher et al.		2012/0031636	A1	2/2012	King	
2002/0198556	A1	12/2002	Ark et al.		2012/0066919	A1*	3/2012	Holba	B25F 3/00
2003/0014067	A1*	1/2003	Kullmer	B23D 61/006					30/507
				606/176	2012/0073410	A1	3/2012	Hoffman et al.	
2003/0032971	A1	2/2003	Hausmann et al.		2012/0090863	A1	4/2012	Puzio et al.	
2004/0098000	A1	5/2004	Kleinwachter		2012/0144676	A1*	6/2012	Davidian	B23D 61/006
2004/0138668	A1*	7/2004	Fisher	B23D 51/10					30/142
				606/82	2012/0144971	A1	6/2012	Bohne	
2004/0204731	A1	10/2004	Gant		2012/0169018	A1	7/2012	Lu et al.	
2004/0243136	A1	12/2004	Gupta et al.		2012/0311876	A1*	12/2012	Zhang	B23D 61/006
2005/0178261	A1	8/2005	Thomaschewski						30/347
2005/0245935	A1	11/2005	Casey et al.		2013/0104719	A1	5/2013	Rubens et al.	
2006/0150428	A1	7/2006	Baculy		2013/0193655	A1	8/2013	Kaye et al.	
2006/0172669	A1	8/2006	Hesse et al.		2014/0035242	A1	2/2014	Kaye et al.	
2006/0217048	A1	9/2006	Frech et al.		2014/0190328	A1*	7/2014	Karlen	B23D 61/006
2006/0272468	A1	12/2006	Gupta et al.						83/853
2006/0282108	A1	12/2006	Tanner		2014/0252729	A1	9/2014	Xu	
2007/0060030	A1	3/2007	Pollak et al.		2014/0299345	A1	10/2014	McRoberts et al.	
2007/0093190	A1	4/2007	Schomisch		2014/0325855	A1	11/2014	Bozic	
2007/0229853	A1	10/2007	Cheng		2016/0184956	A1	6/2016	Klabunde et al.	
2007/0266837	A1	11/2007	Nickels et al.		2016/0199919	A1	7/2016	Klabunde et al.	
2007/0295156	A1	12/2007	Ziegler et al.		2016/0288288	A1	10/2016	Klabunde et al.	
2007/0295165	A1	12/2007	Tanaka et al.						
2008/0027449	A1	1/2008	Gundlapalli et al.						
2008/0190259	A1	8/2008	Bohne						
2008/0196911	A1	8/2008	Krapf et al.						
2009/0013540	A1	1/2009	Bohne						
2009/0023371	A1	1/2009	Bfickle et al.						
2009/0051094	A1	2/2009	Sandmeier						
2009/0093815	A1	4/2009	Fletcher et al.						
2009/0138017	A1	5/2009	Carusillo et al.						
2009/0197514	A1	8/2009	Peisert						
2009/0198465	A1	8/2009	Decker et al.						
2009/0277022	A1	11/2009	Limberg et al.						
2009/0312761	A1	12/2009	Boykin et al.						
2009/0312762	A1	12/2009	Boykin						
2009/0312779	A1	12/2009	Boykin et al.						
2009/0318065	A1	12/2009	Zaiser et al.						
2009/0320625	A1	12/2009	Kildevaeld						
2009/0321625	A1	12/2009	Sieradzki et al.						
2010/0003906	A1	1/2010	Zaiser et al.						
2010/0009613	A1	1/2010	Frueh						
2010/0052269	A1	3/2010	Zaiser et al.						
2010/0056029	A1*	3/2010	Grunikiewicz	B23B 31/008					
				451/442					
2010/0193207	A1	8/2010	Mok et al.						
2010/0197208	A1	8/2010	Blickle et al.						
2010/0288099	A1	11/2010	Steiger						
2010/0300714	A1	12/2010	Trautner						
2011/0000690	A1	1/2011	Kildevaeld						
2011/0011605	A1*	1/2011	Kildevaeld	B23D 51/10					
				173/1					
2011/0067894	A1	3/2011	Bernardi						
2011/0072946	A1	3/2011	Bemardi et al.						
2011/0086582	A1	4/2011	Takemura et al.						
2011/0097978	A1	4/2011	Hofmann et al.						
2011/0127731	A1	6/2011	Woecht et al.						
2011/0139472	A1	6/2011	Bohne						
2011/0147023	A1	6/2011	Herr						
2011/0227300	A1*	9/2011	Zhang	B24B 23/04					
				279/143					
2011/0260414	A1*	10/2011	Ota	B24B 23/02					
				279/8					
2011/0266757	A1	11/2011	Steadings et al.						
2011/0266758	A1*	11/2011	Sergyeyenko	B24B 23/04					
				279/106					
2011/0266759	A1	11/2011	Goldman						
2011/0277611	A1*	11/2011	Chen	B23D 61/006					
				83/699.51					
2011/0291368	A1	12/2011	Chen et al.						

FOREIGN PATENT DOCUMENTS

AU	2006305634		4/2007
CH	657411	A5	8/1986
CN	201728642		2/2011
DE	1878647	U	8/1963
DE	2915292	A1	10/1980
DE	2935731	A1	4/1981
DE	3203670	A1	8/1983
DE	3520417	A1	12/1985
DE	3833735	A1	4/1989
DE	8618695	U1	9/1989
DE	4036904	C1	5/1992
DE	4209146	A1	9/1992
DE	29605728	U1	9/1996
DE	29607061	U1	10/1996
DE	29810157	U1	8/1998
DE	19736933	C1	10/1998
DE	29907671	U1	8/1999
DE	29809788	U1	9/1999
DE	19825408	A1	12/1999
DE	20303018	U1	4/2003
DE	10231393		1/2004
DE	10307840	B3	6/2004
DE	10325392	A1	12/2004
DE	102004020982	A1	11/2005
DE	202006001643	U1	3/2006
DE	102004050799	A1	4/2006
DE	102007018465	A1	10/2008
DE	102007018467	A1	10/2008
DE	202009004549	U1	6/2009
DE	202008001759	U1	7/2009
DE	102008001234	A1	10/2009
DE	202009013147	U1	1/2010
DE	202008011959	U1	2/2010
DE	102009030854	A1	1/2011
DE	202011050511	U1	11/2011
DE	202011051408	U1	2/2012
DE	102011005818	A1	9/2012
DE	102011085561	A1	12/2012
DE	102012201624	A1	8/2013
EP	0443362	A2	8/1991
EP	0554929	A1	8/1993
EP	0695607	A1	2/1996
EP	0776634	A2	6/1997
EP	0962283	A1	12/1999
EP	1694477	A1	6/2005

EP	1687120	A1	8/2006
EP	1819490	A1	8/2007
EP	1852218	A1	11/2007
EP	1882538	A2	1/2008
EP	2085182	A1	8/2009
EP	2143531	A1	1/2010
EP	2152475	A1	2/2010
EP	2159000	A1	3/2010
JP	1158205	A	6/1989
JP	2006263914	A	10/2006
WO	WO-9424945	A1	11/1994
WO	WO-03097299	A1	11/2003
WO	WO-2004043269	A1	5/2004
WO	WO-2005056256	A1	6/2005
WO	WO-2006017066	A2	2/2006
WO	WO-2008151866	A1	12/2008
WO	WO-2009151958	A2	12/2009
WO	WO-2009151959	A1	12/2009
WO	WO-2009151965	A1	12/2009
WO	WO-2010020458	A1	2/2010
WO	WO-2013067960	A1	5/2013

OTHER PUBLICATIONS

Kornmeier, Martin—Extended European Search Report re: Related European Patent Application No. 13163355.4—Nov. 27, 2017—5 pages—European Patent Office—Munich.

Zimmer Inc., Brochure “Air Drive Blades—The Next Generation” dated Jun. 28, 1993, 1 page; © 1993 Zimmer, Inc.

Zimmer, Inc., Brochure “More Versatile ‘Graft’ Blades Available” dated Feb. 15, 1993, 2 pages; © 1993 Zimmer, Inc.

Materials from Stryker Corporation Brochure published prior to Jan. 1, 1994.

Aloe Medical Instruments “Gall Ball Retractor” Item B-1323, p. 115 © 1965.

Stryker Maintenance Manual entitled “System II OrthoPower 90 Battery Powered Surgical Instruments”—For Use With: 298-92, 94,96, 98 (Stryker Surgical Brochure 298-92-16 Rev (Mar. 1986). Sketch A related to p. 9 of the Stryker Maintenance Manual entitled “System II OrthoPower 90 Battery Powered Surgical Instruments” (Mar. 1986).

Copies of pp. 2, 3 and 5 of Stryker prior art brochure/-catalog No. 1420 Standard Bone Saw Handpiece, 1100 Series saw blades, and No. 1470 Sagittal Plane bone saw with Series 1370 blades.

Hall Surgical brochure—New Opposed-Tooth Blades—published prior to Jan. 1, 1994.

Dremel 6300-05 120-volt Multi-Max Oscillating Kit (retrieved on Sep. 30, 2014) viewed on the internet.<https://web.archive.org/web/20091224220316/http://www.amazon.com/Dremel-6300-05-120-Volt-Multi-Max-Oscillating/dp/B002WTCDXO> published on Dec. 24, 2009 as per Wayback Machine.

Dewaele, Karl—European Search Report—Jun. 20, 2014—7 pages—The Hague.

O’Connell, Wayne—Patent Examination Report No. 3 re Australian Patent Application No. 2011201633—Oct. 2, 2014—6 pages—Woden ACT, Canberra Australia.

Dewaele, Karl—Examination Report re: European Patent Appln. No. 15160839.5-1701—Nov. 9, 2016—6 pages.

* cited by examiner

Primary Examiner — Darlington Ly
(74) Attorney, Agent, or Firm — Scott B. Markow

(57) CLAIM

The ornamental design for a blade for oscillating power tools, as shown and described.

DESCRIPTION

FIG. 1 is a top perspective view of a blade for oscillating power tools showing our new design in accordance to a first embodiment;

FIG. 2 is a right side elevation view thereof;
 FIG. 3 is a left side elevation view thereof;
 FIG. 4 is a rear elevation view thereof;
 FIG. 5 is a front elevation view thereof;
 FIG. 6 is a top plan view thereof;
 FIG. 7 is a bottom plan view thereof; and
 FIG. 8 is a bottom perspective view thereof.
 FIG. 9 is a top perspective view of a blade for oscillating power tools showing our new design in accordance to a second embodiment;
 FIG. 10 is a right side elevation view thereof;
 FIG. 11 is a left side elevation view thereof;
 FIG. 12 is a rear elevation view thereof;
 FIG. 13 is a front elevation view thereof;
 FIG. 14 is a top plan view thereof;
 FIG. 15 is a bottom plan view thereof; and
 FIG. 16 is a bottom perspective view thereof.
 FIG. 17 is a top perspective view of a blade for oscillating power tools showing our new design in accordance to a third embodiment;
 FIG. 18 is a right side elevation view thereof;
 FIG. 19 is a left side elevation view thereof;
 FIG. 20 is a rear elevation view thereof;
 FIG. 21 is a front elevation view thereof;
 FIG. 22 is a top plan view thereof;
 FIG. 23 is a bottom plan view thereof; and
 FIG. 24 is a bottom perspective view thereof.
 FIG. 25 is a top perspective view of a blade for oscillating power tools showing our new design in accordance to a fourth embodiment;
 FIG. 26 is a right side elevation view thereof;
 FIG. 27 is a left side elevation view thereof;
 FIG. 28 is a rear elevation view thereof;
 FIG. 29 is a front elevation view thereof;
 FIG. 30 is a top plan view thereof;
 FIG. 31 is a bottom plan view thereof; and
 FIG. 32 is a bottom perspective view thereof.
 FIG. 33 is a top perspective view of a blade for oscillating power tools showing our new design in accordance to a fifth embodiment;
 FIG. 34 is a right side elevation view thereof;
 FIG. 35 is a left side elevation view thereof;
 FIG. 36 is a rear elevation view thereof;
 FIG. 37 is a front elevation view thereof;
 FIG. 38 is a top plan view thereof;
 FIG. 39 is a bottom plan view thereof; and
 FIG. 40 is a bottom perspective view thereof.
 FIG. 41 is a top perspective view of a blade for oscillating power tools showing our new design in accordance to a sixth embodiment;
 FIG. 42 is a right side elevation view thereof;
 FIG. 43 is a left side elevation view thereof;
 FIG. 44 is a rear elevation view thereof;
 FIG. 45 is a front elevation view thereof;
 FIG. 46 is a top plan view thereof;
 FIG. 47 is a bottom plan view thereof; and
 FIG. 48 is a bottom perspective view thereof.
 FIG. 49 is a top perspective view of a blade for oscillating power tools showing our new design in accordance to a seventh embodiment;
 FIG. 50 is a right side elevation view thereof;
 FIG. 51 is a left side elevation view thereof;
 FIG. 52 is a rear elevation view thereof;
 FIG. 53 is a front elevation view thereof;
 FIG. 54 is a top plan view thereof;

FIG. 55 is a bottom plan view thereof; and
FIG. 56 is a bottom perspective view thereof.
FIG. 57 is a top perspective view of a blade for oscillating power tools showing our new design in accordance to an eighth embodiment;
FIG. 58 is a right side elevation view thereof;
FIG. 59 is a left side elevation view thereof;
FIG. 60 is a rear elevation view thereof;
FIG. 61 is a front elevation view thereof;
FIG. 62 is a top plan view thereof;
FIG. 63 is a bottom plan view thereof; and,
FIG. 64 is a bottom perspective view thereof.
The broken lines in the drawings illustrate portions of the blade for oscillating power tools that form no part of the claimed design.

1 Claim, 48 Drawing Sheets

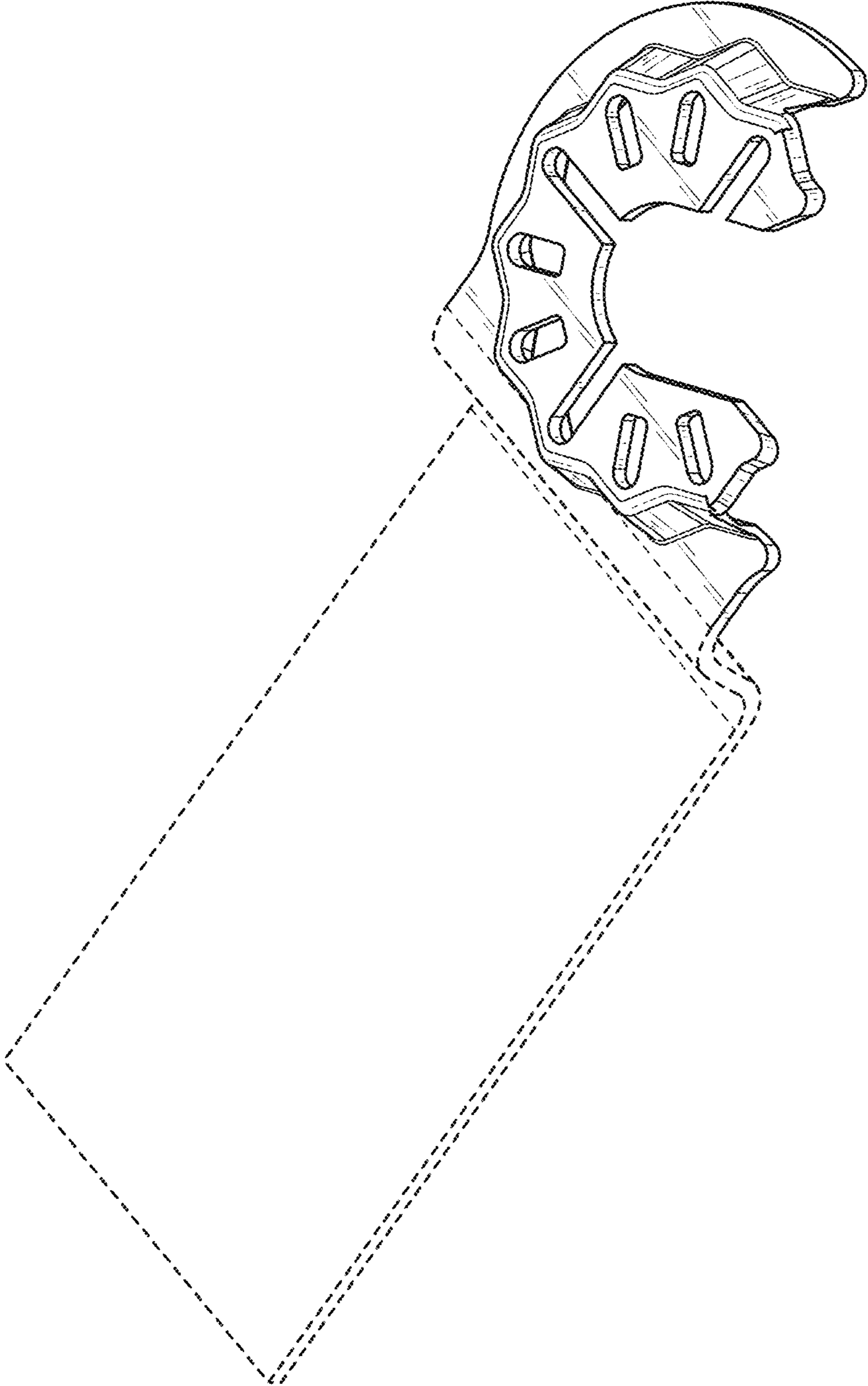

FIG. 1

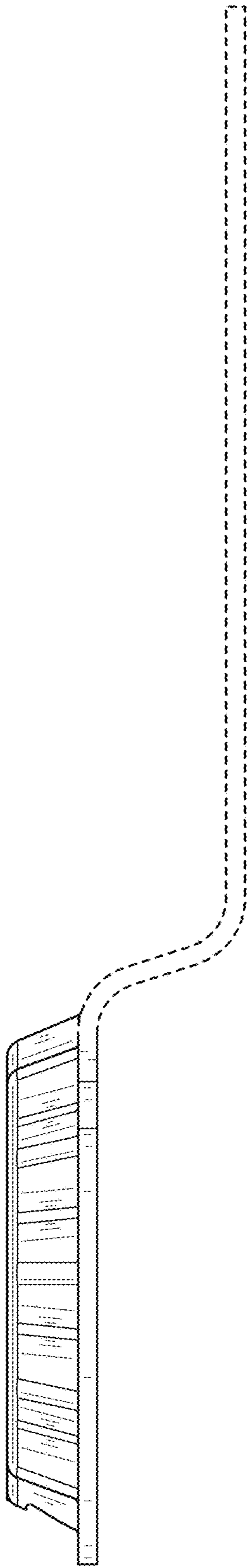

FIG. 2

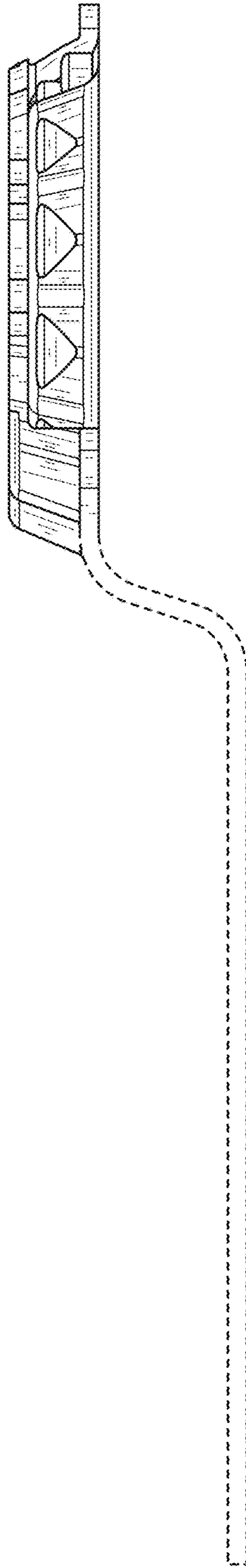

FIG. 3

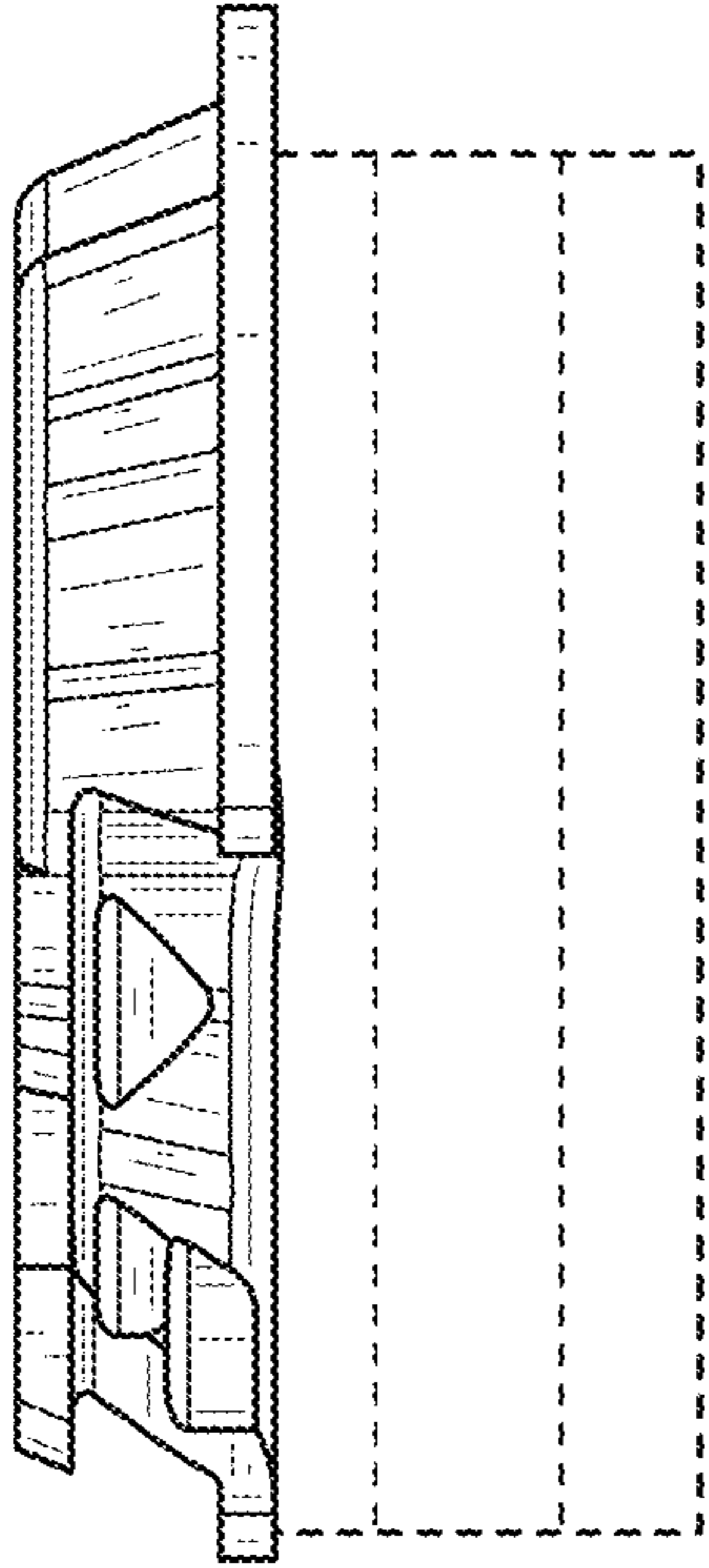

FIG. 4

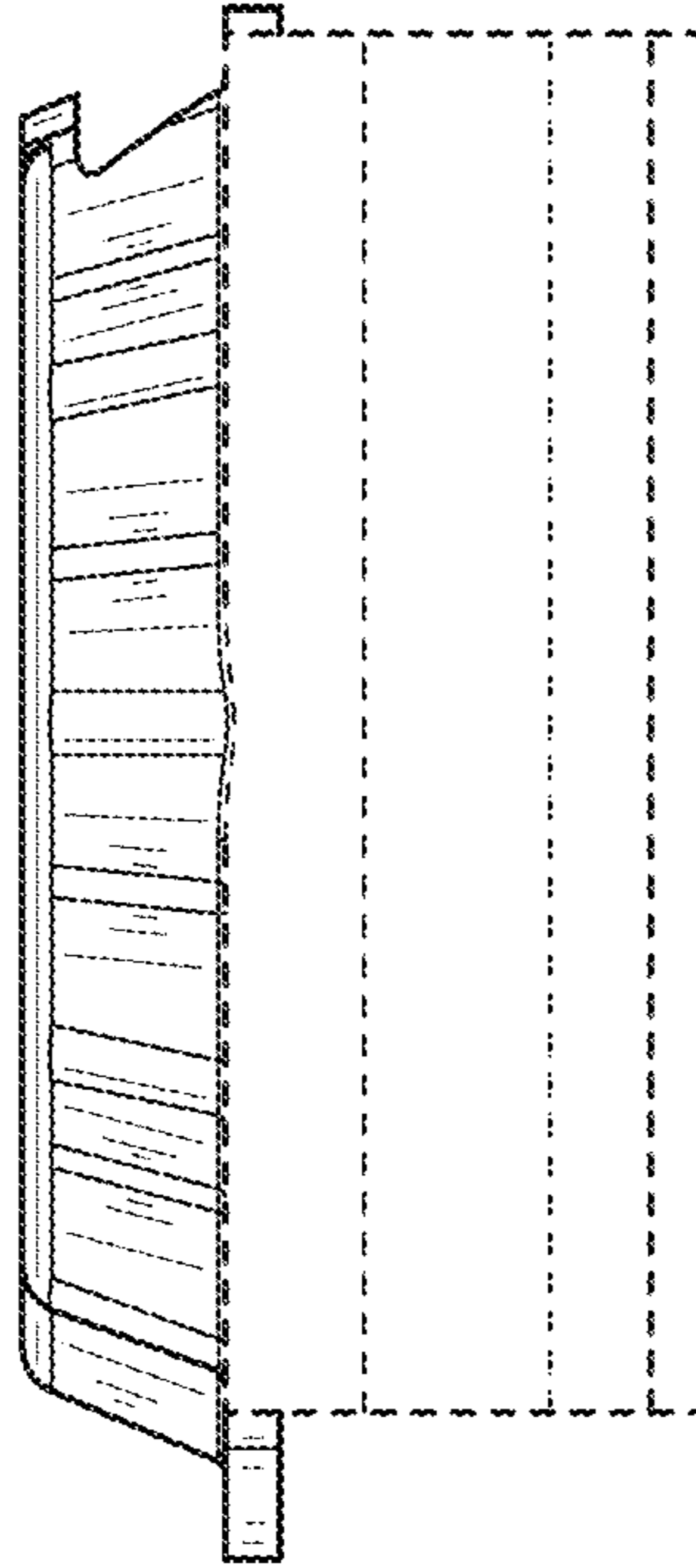

FIG. 5

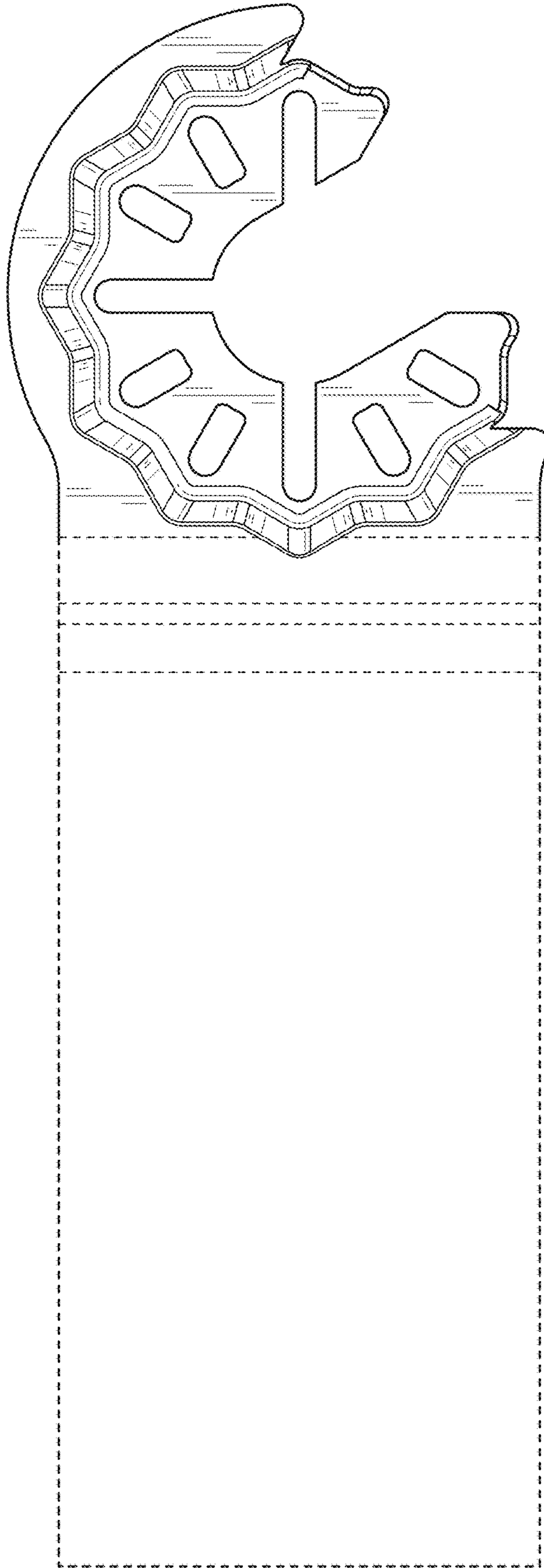

FIG. 6

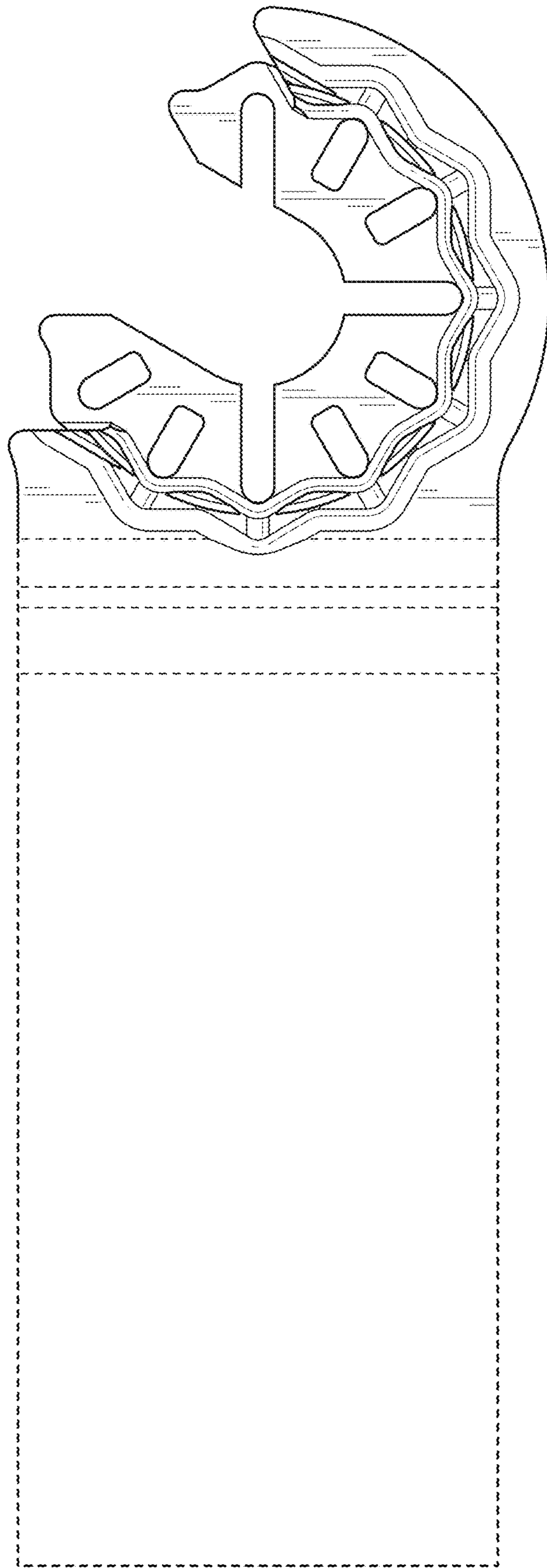

FIG. 7

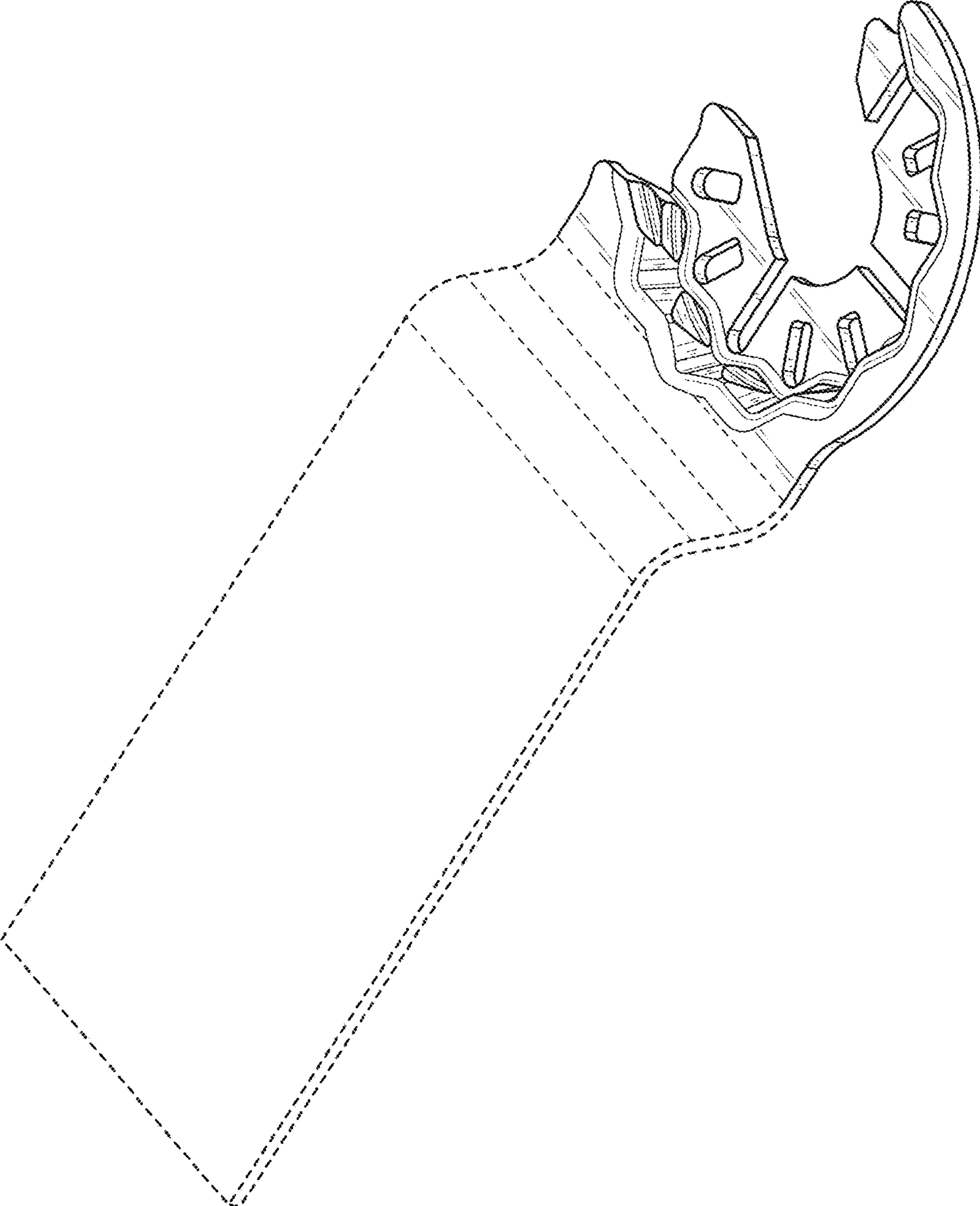

FIG. 8

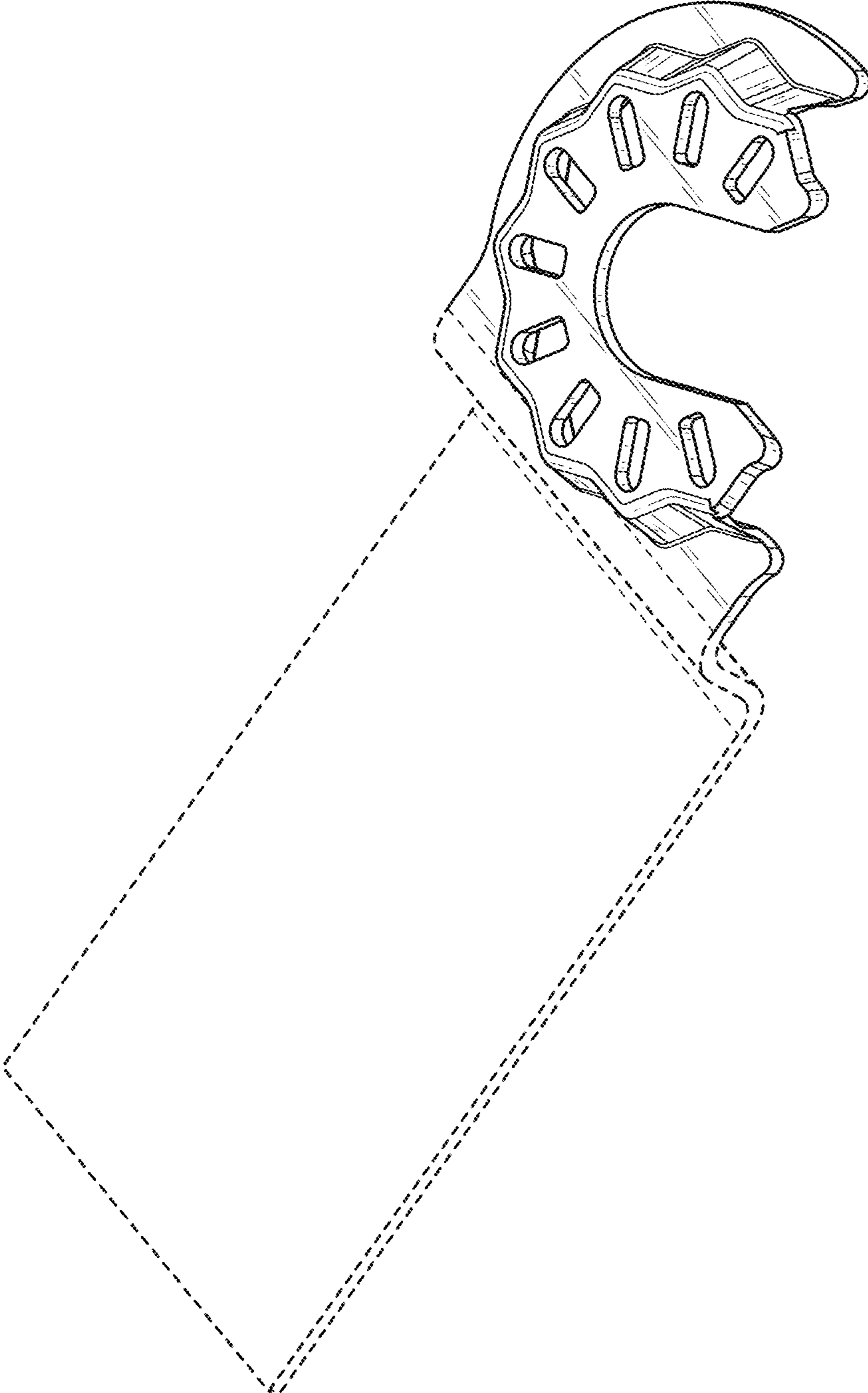

FIG. 9

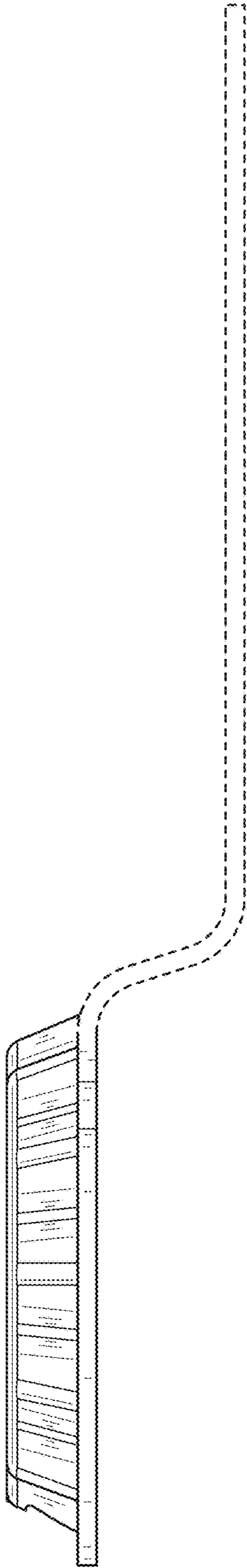

FIG. 10



FIG. 11

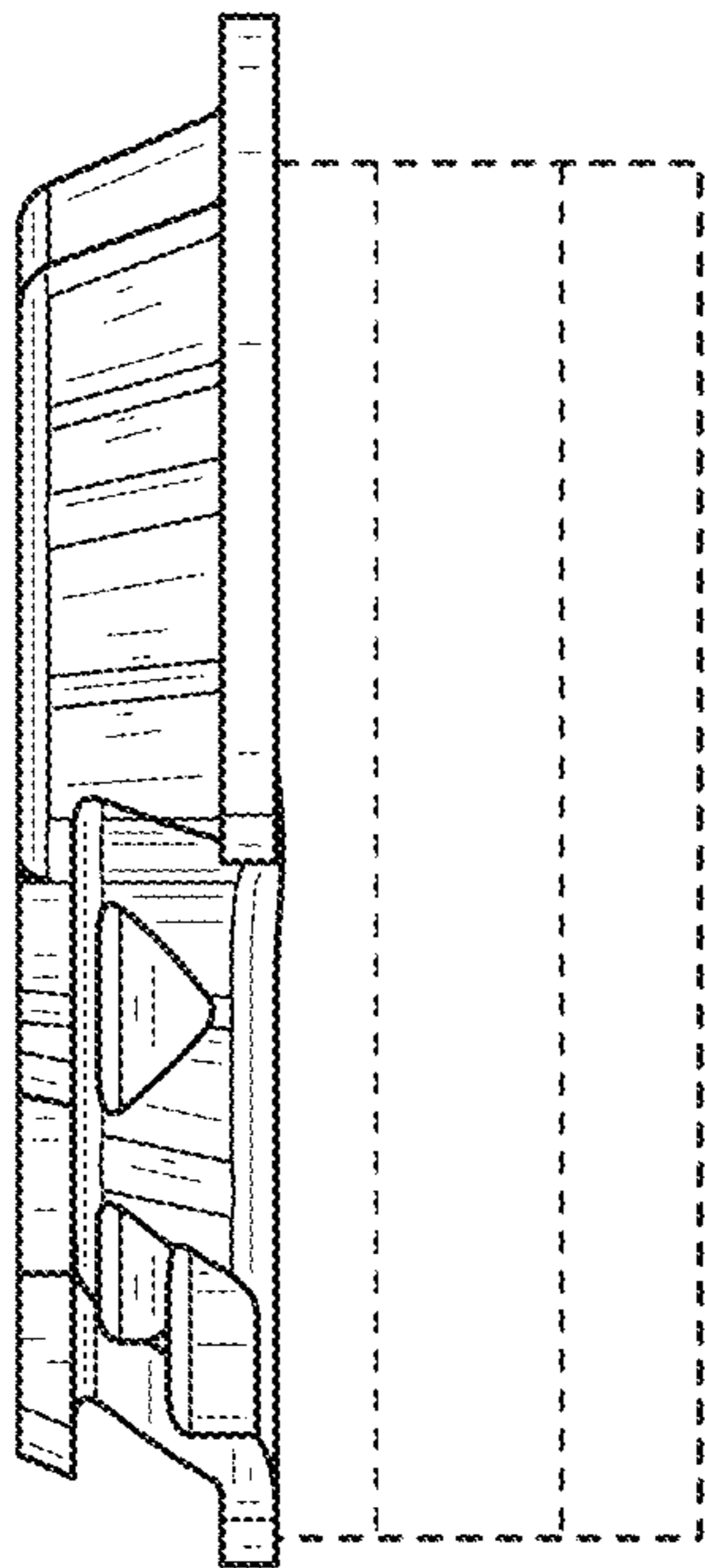

FIG. 12

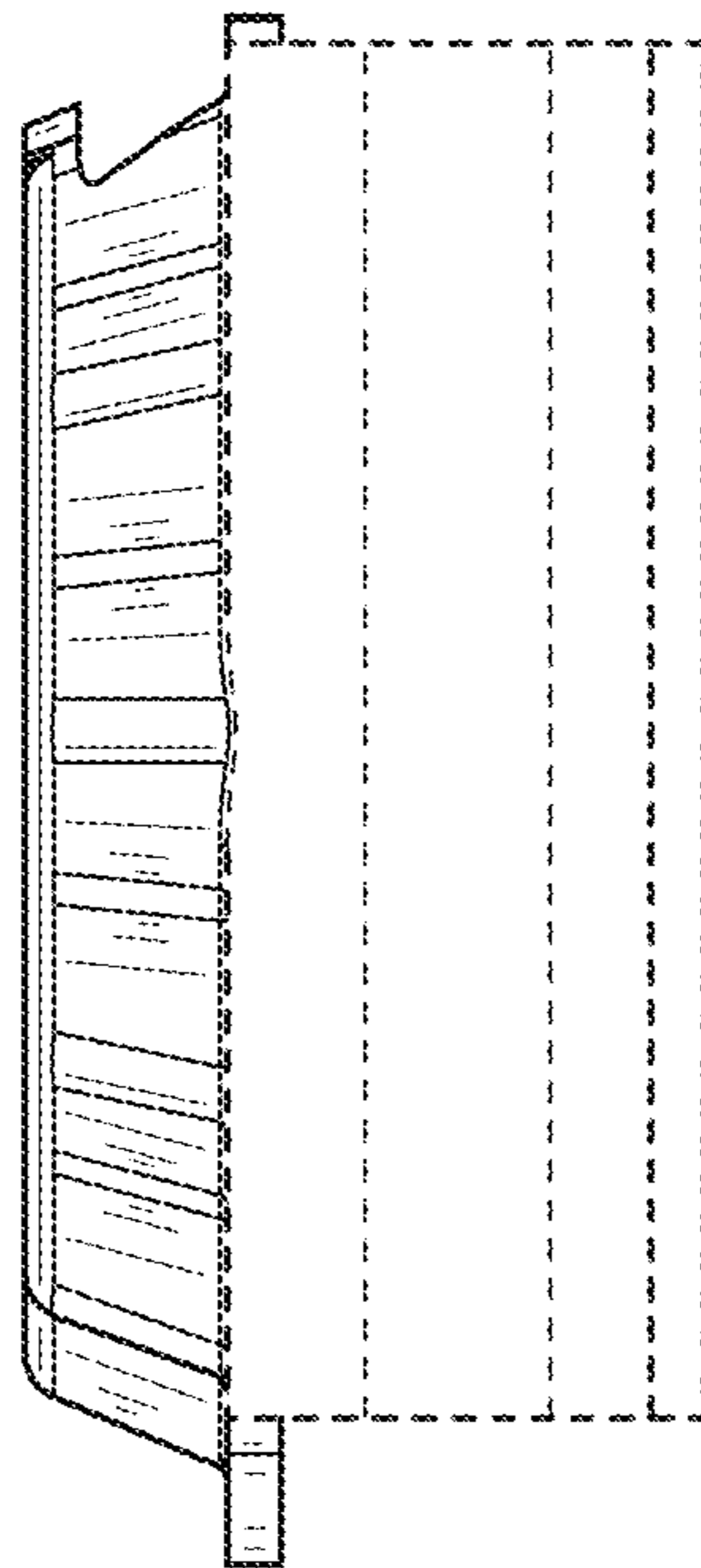

FIG. 13

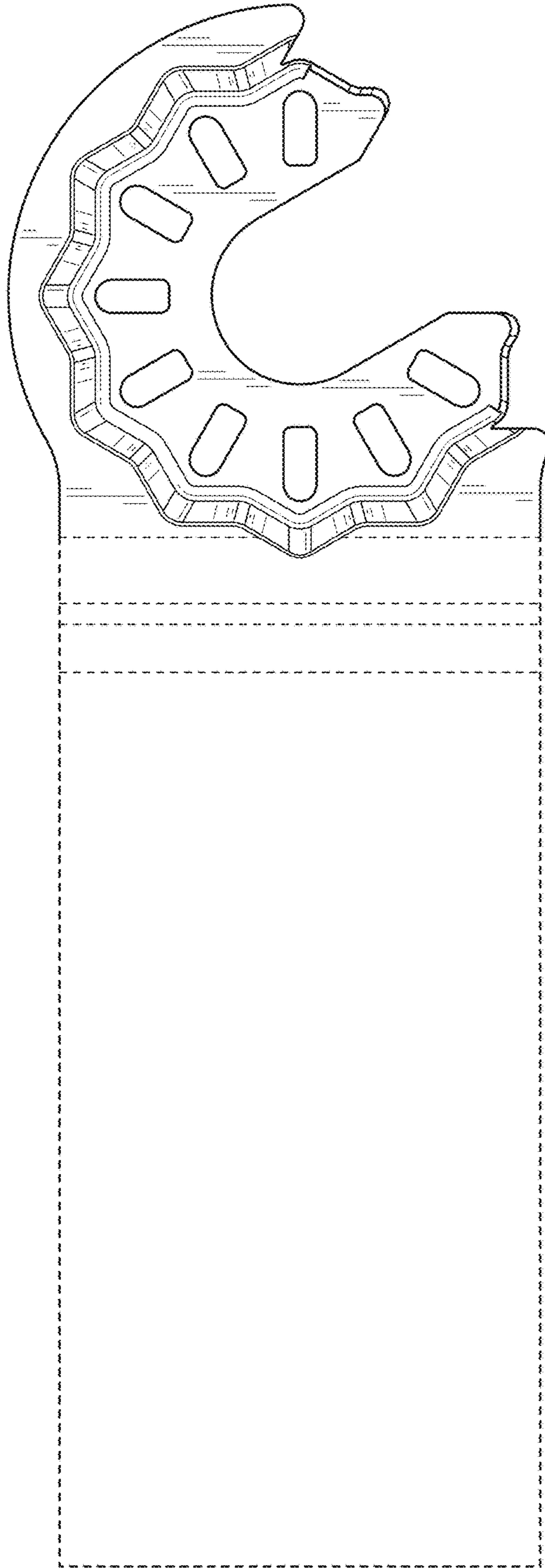

FIG. 14

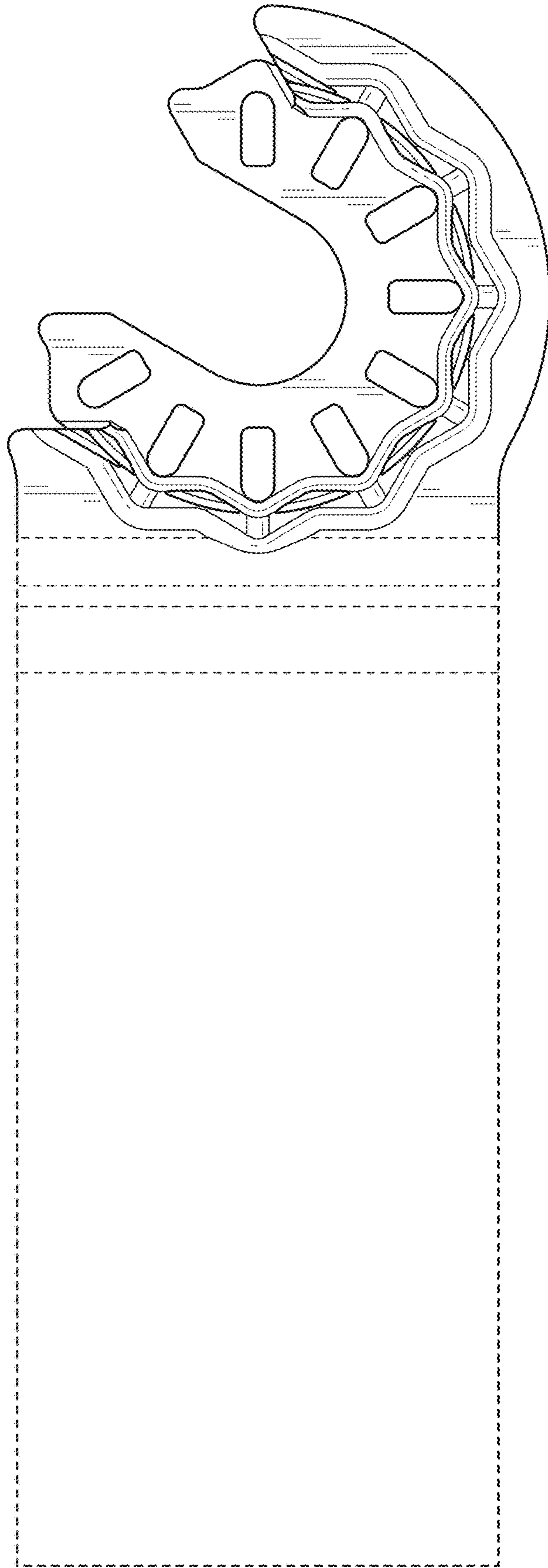

FIG. 15

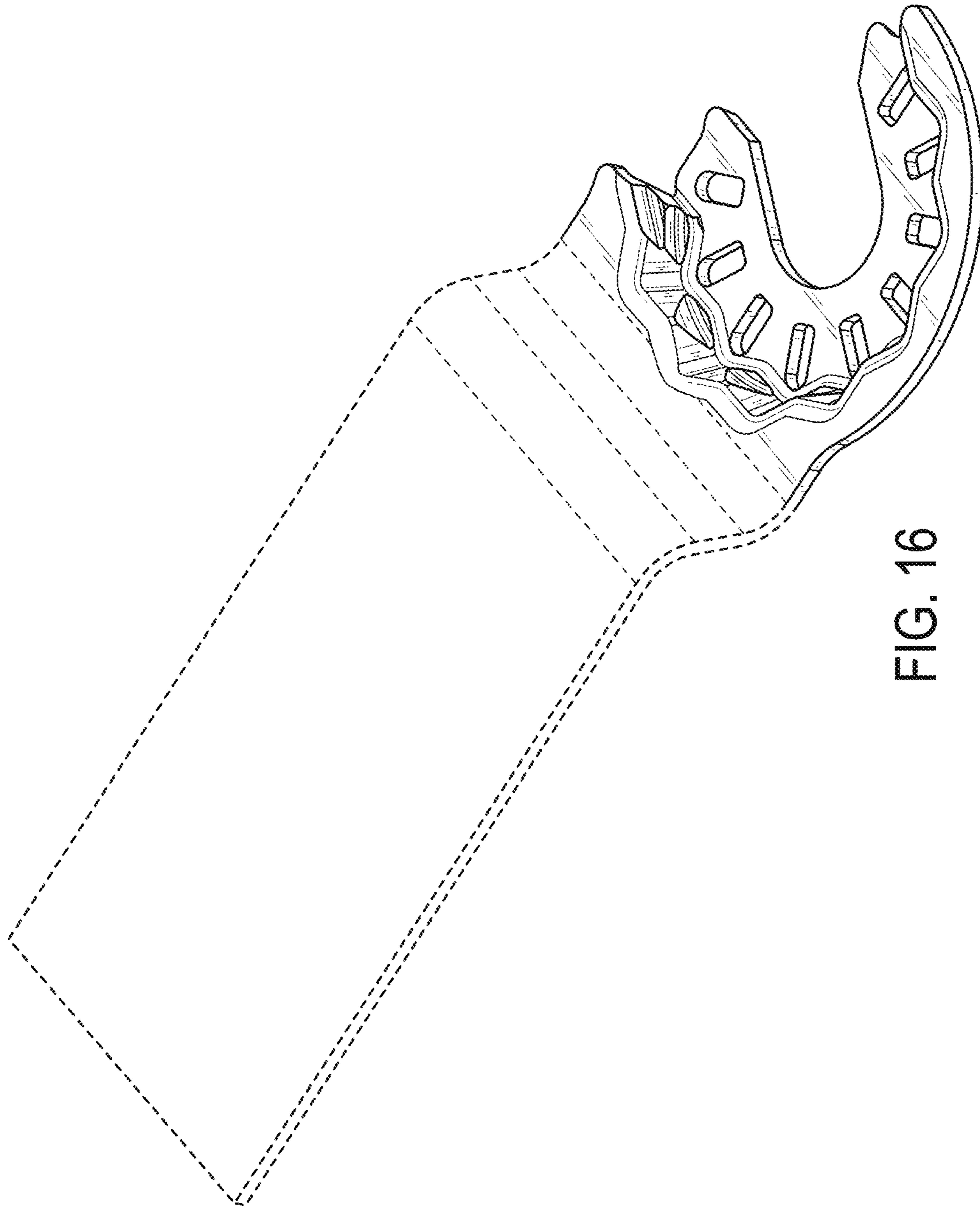

FIG. 16

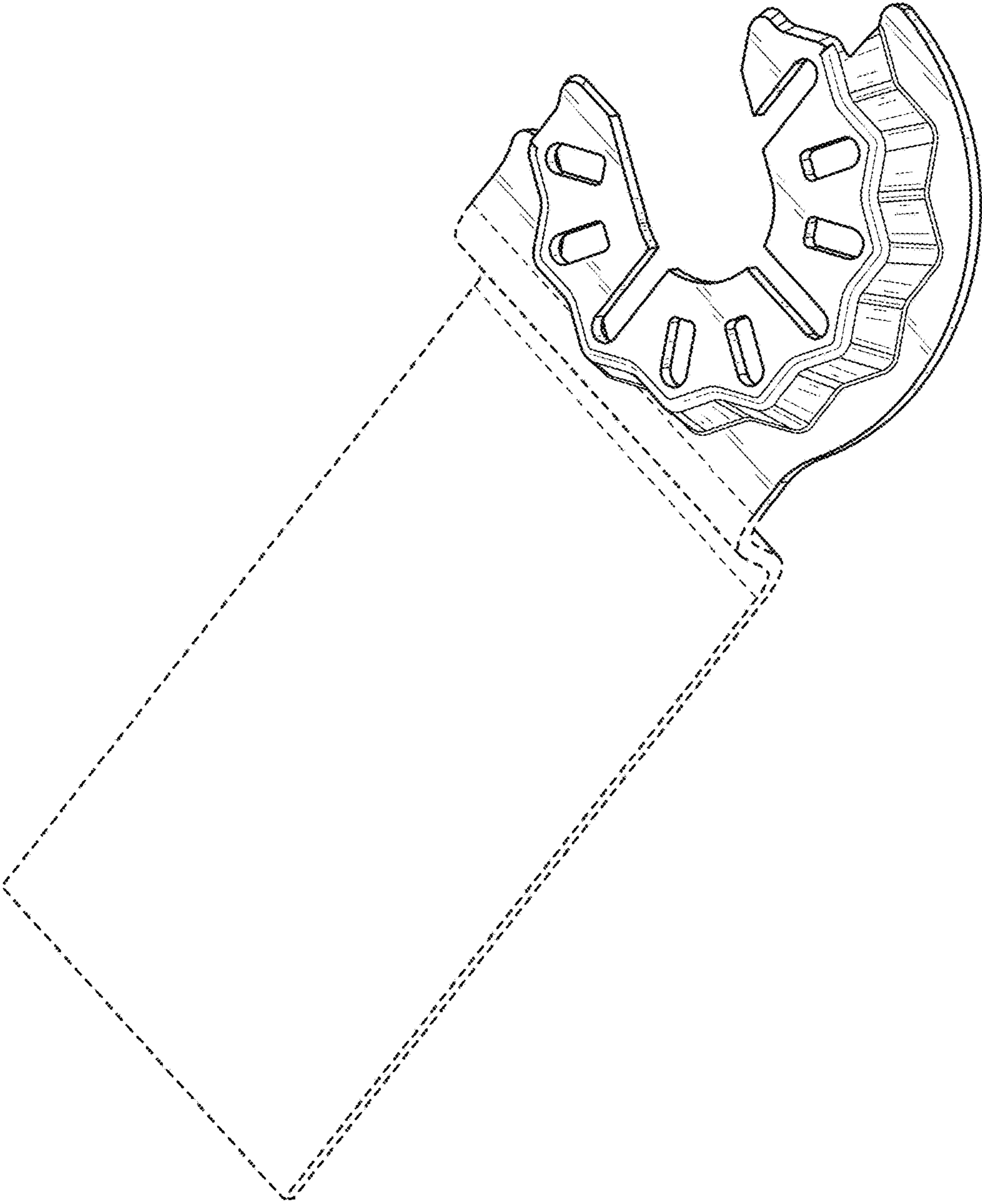

FIG. 17

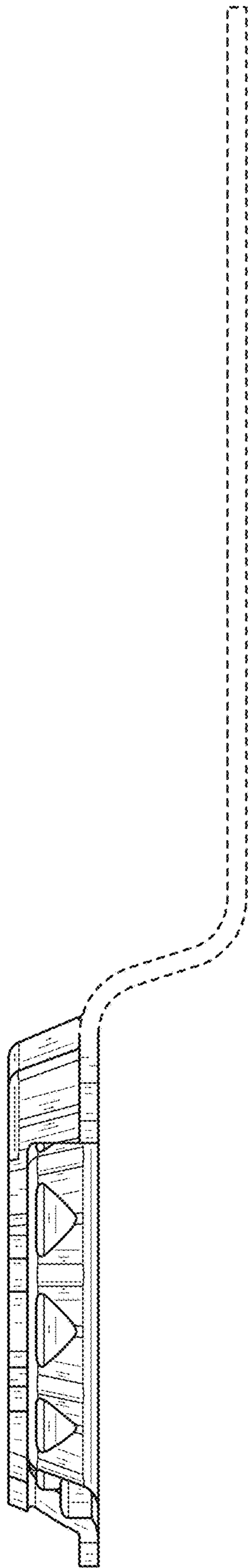

FIG. 18

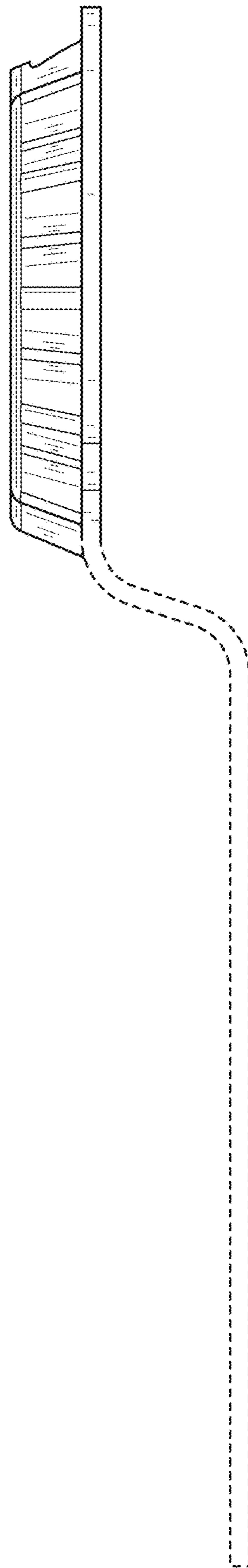

FIG. 19

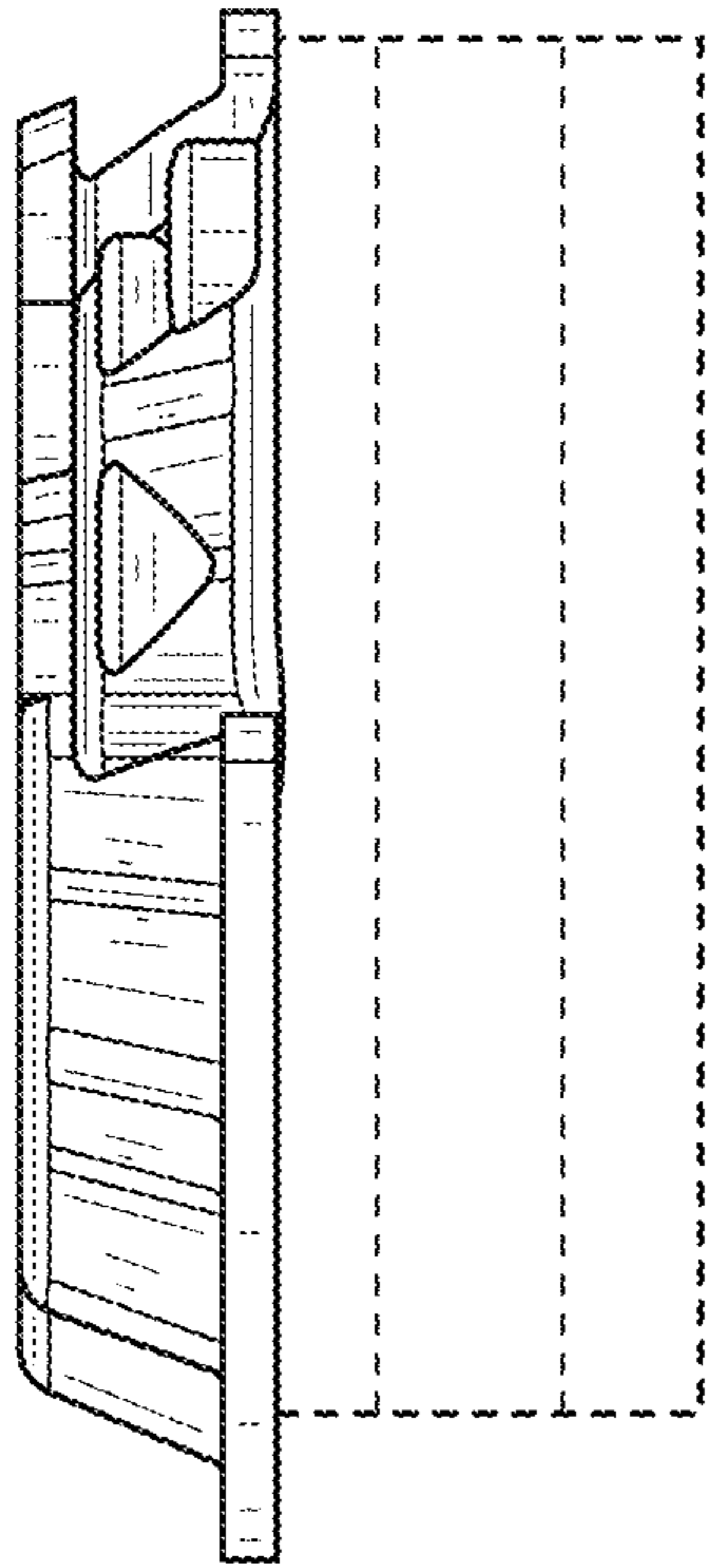

FIG. 20

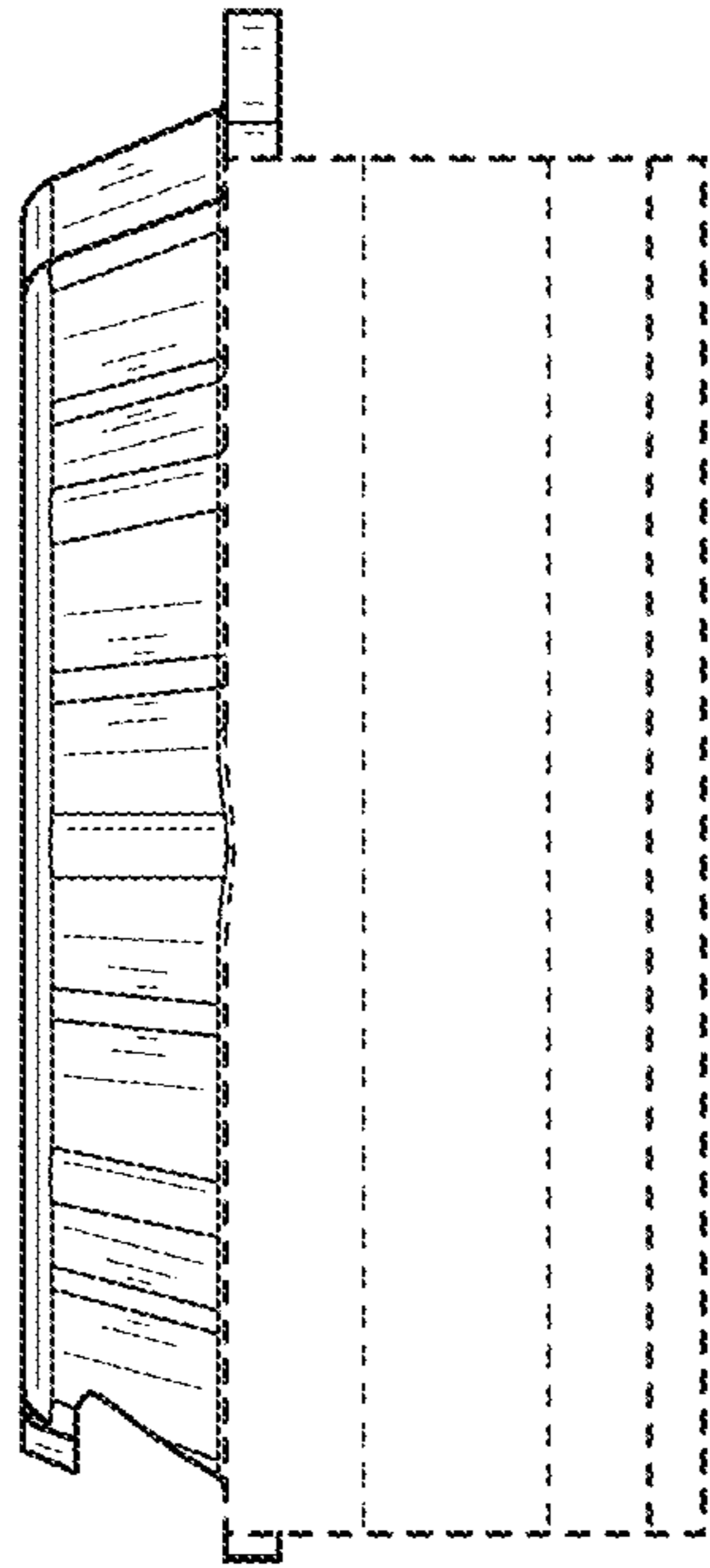

FIG. 21

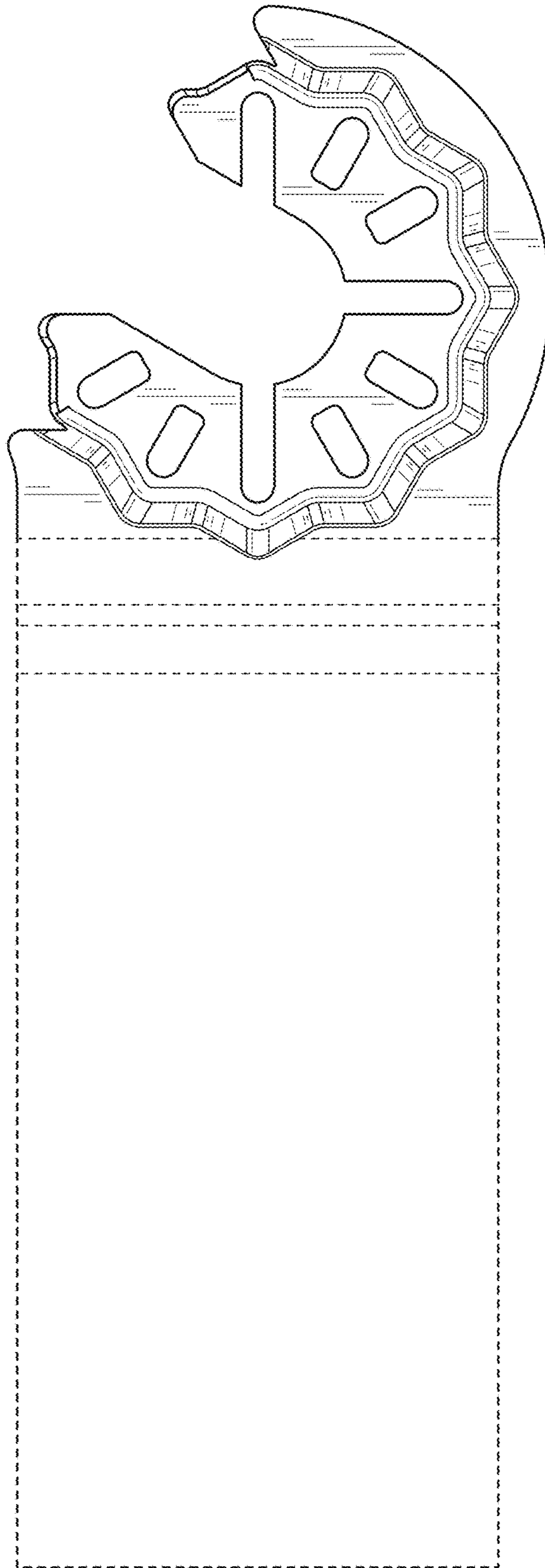

FIG. 22

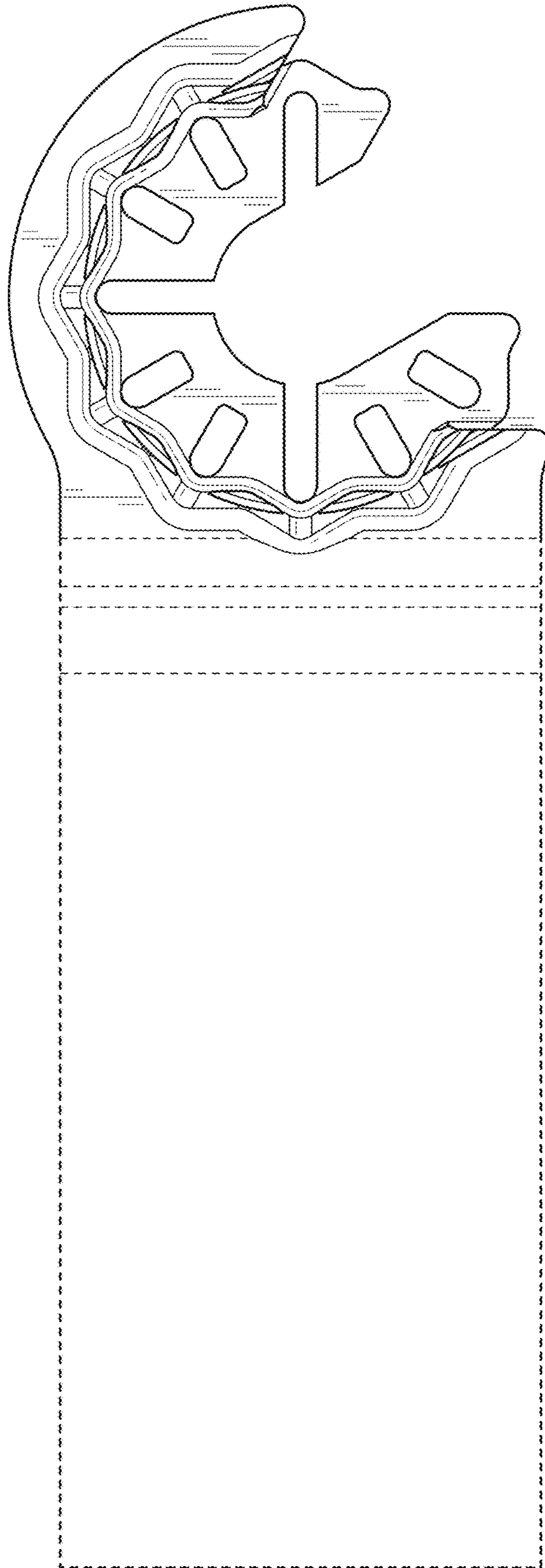

FIG. 23

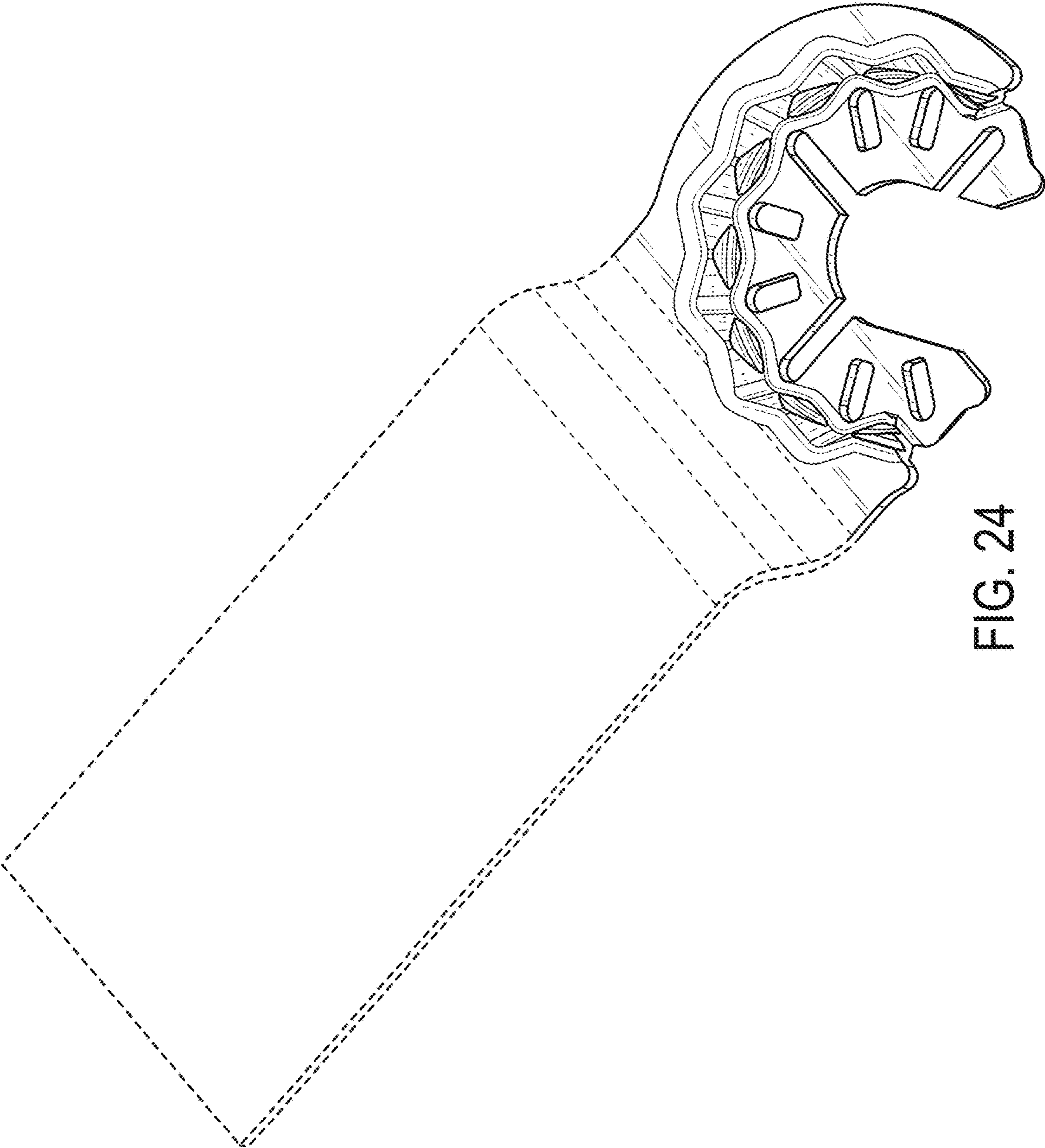

FIG. 24

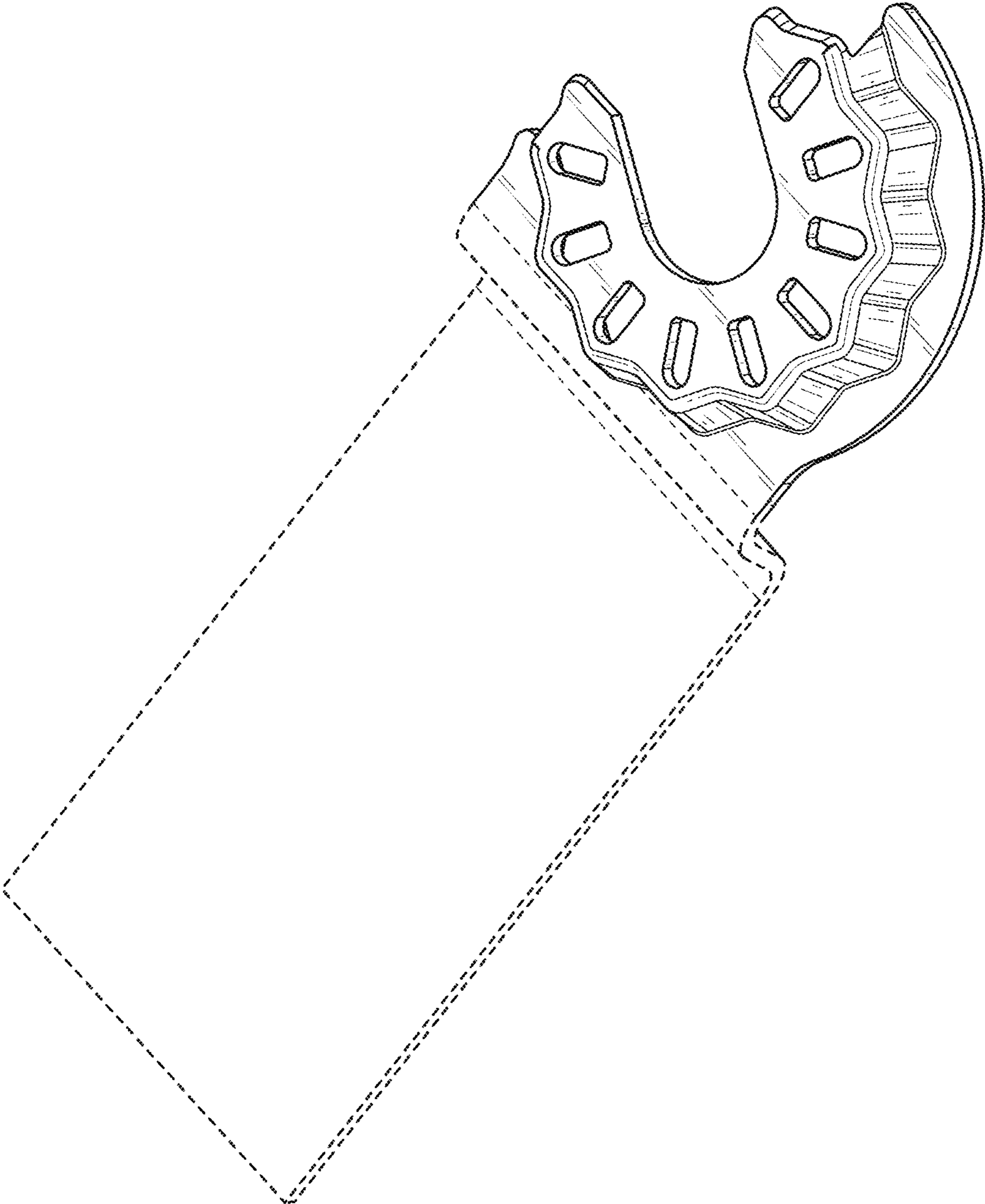

FIG. 25

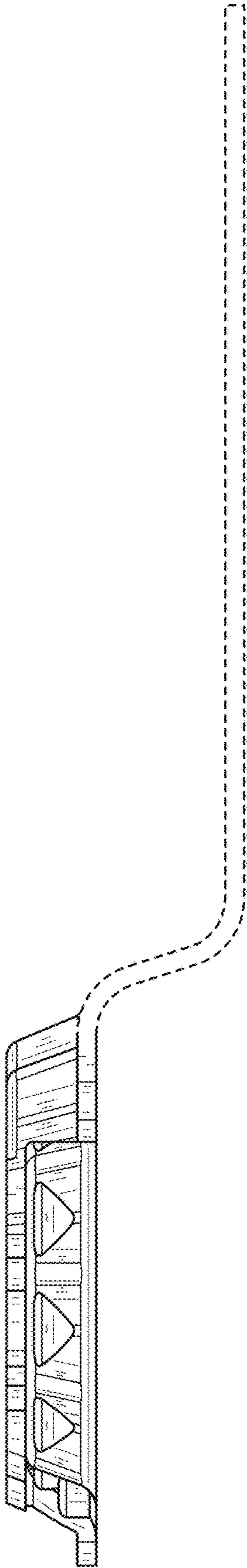

FIG. 26

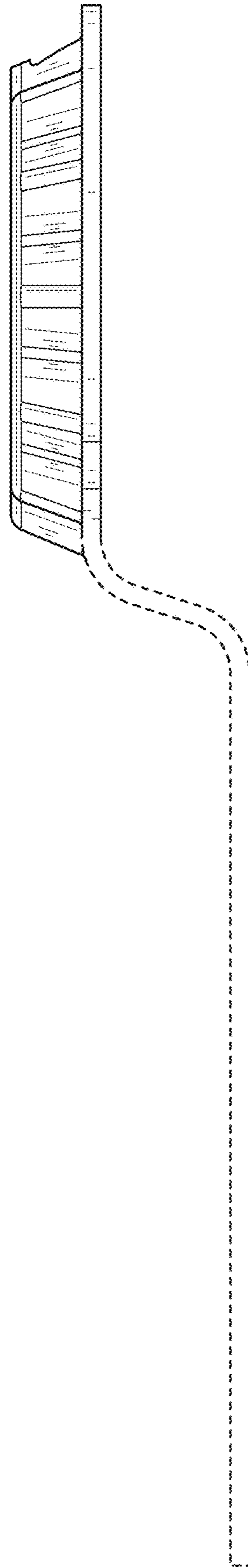

FIG. 27

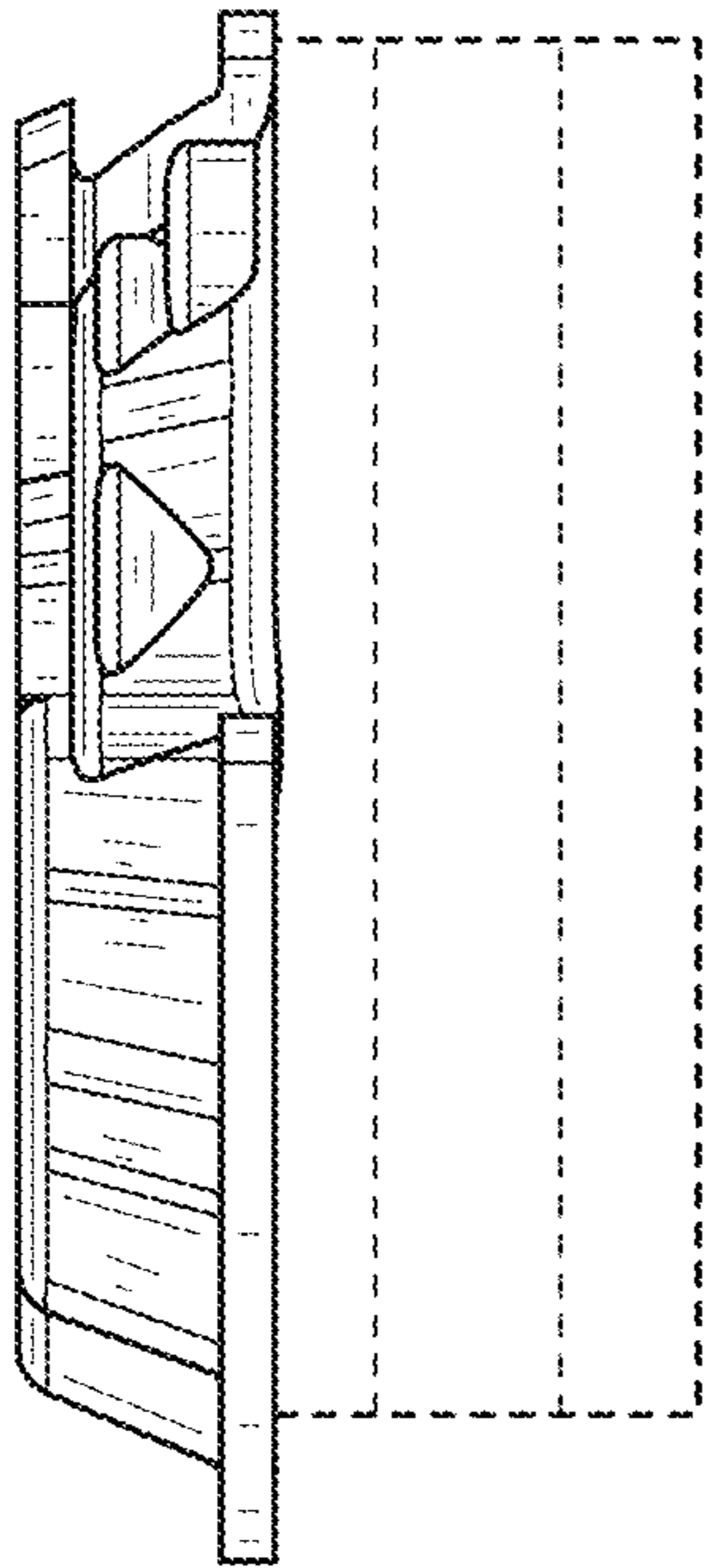

FIG. 28

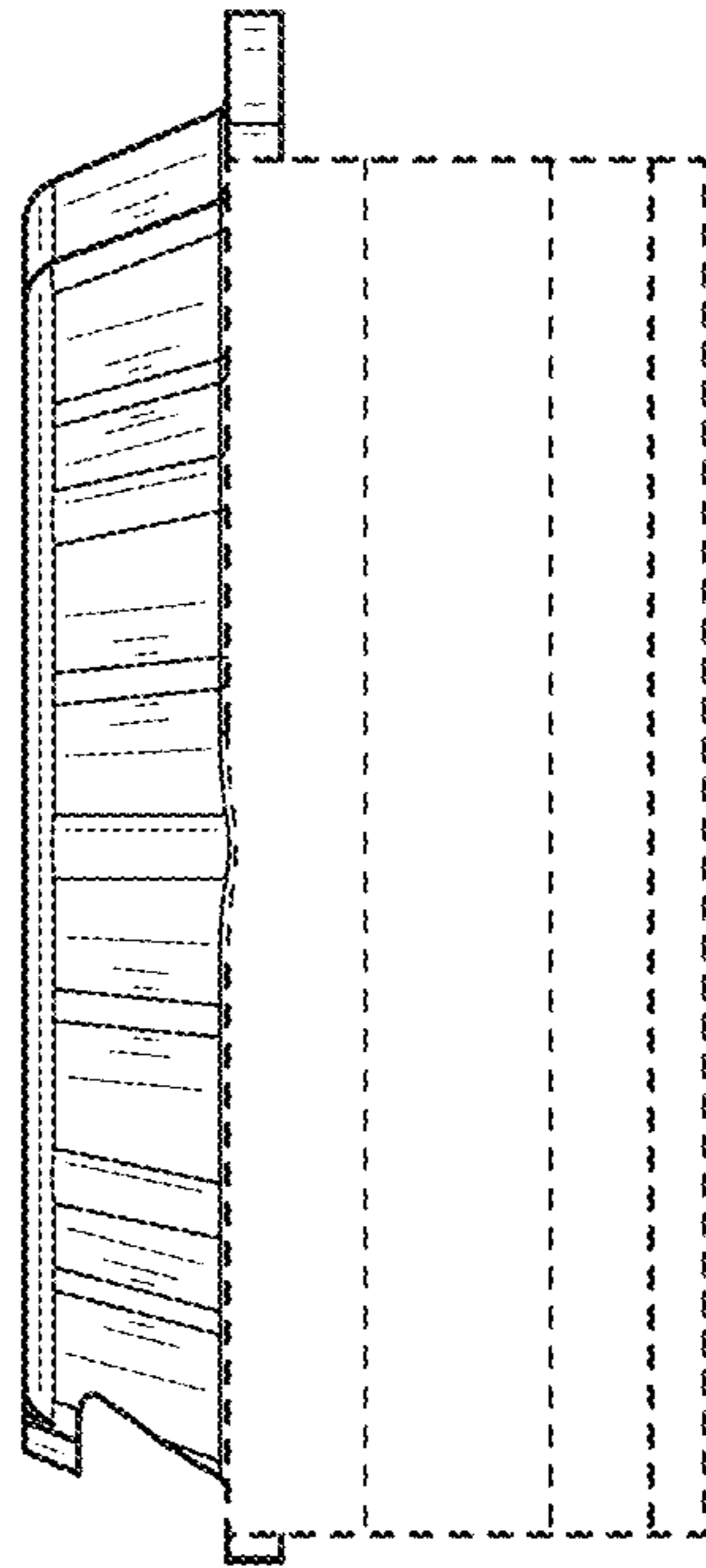

FIG. 29

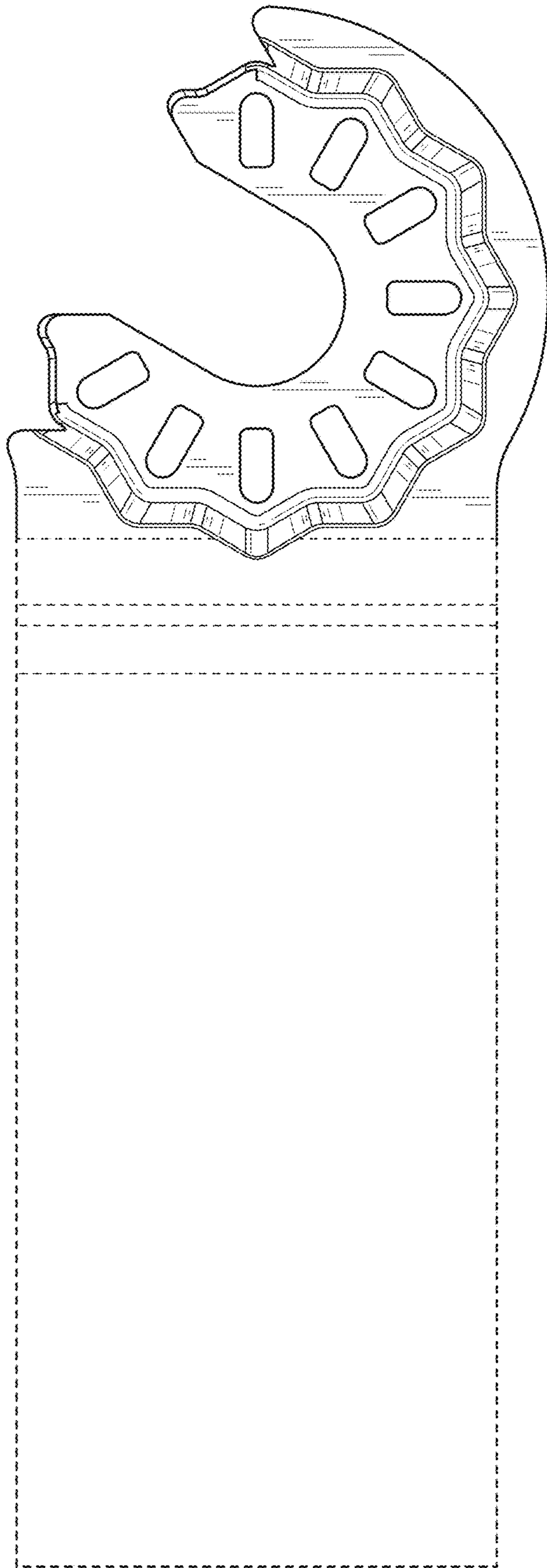

FIG. 30

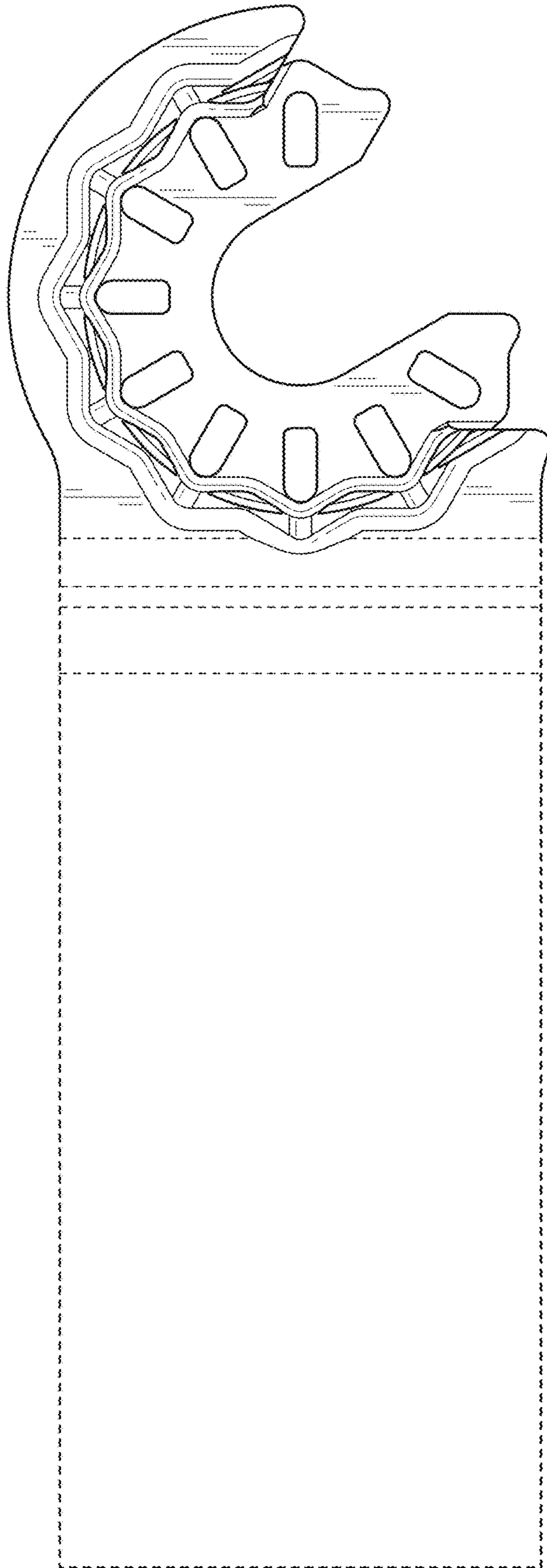

FIG. 31

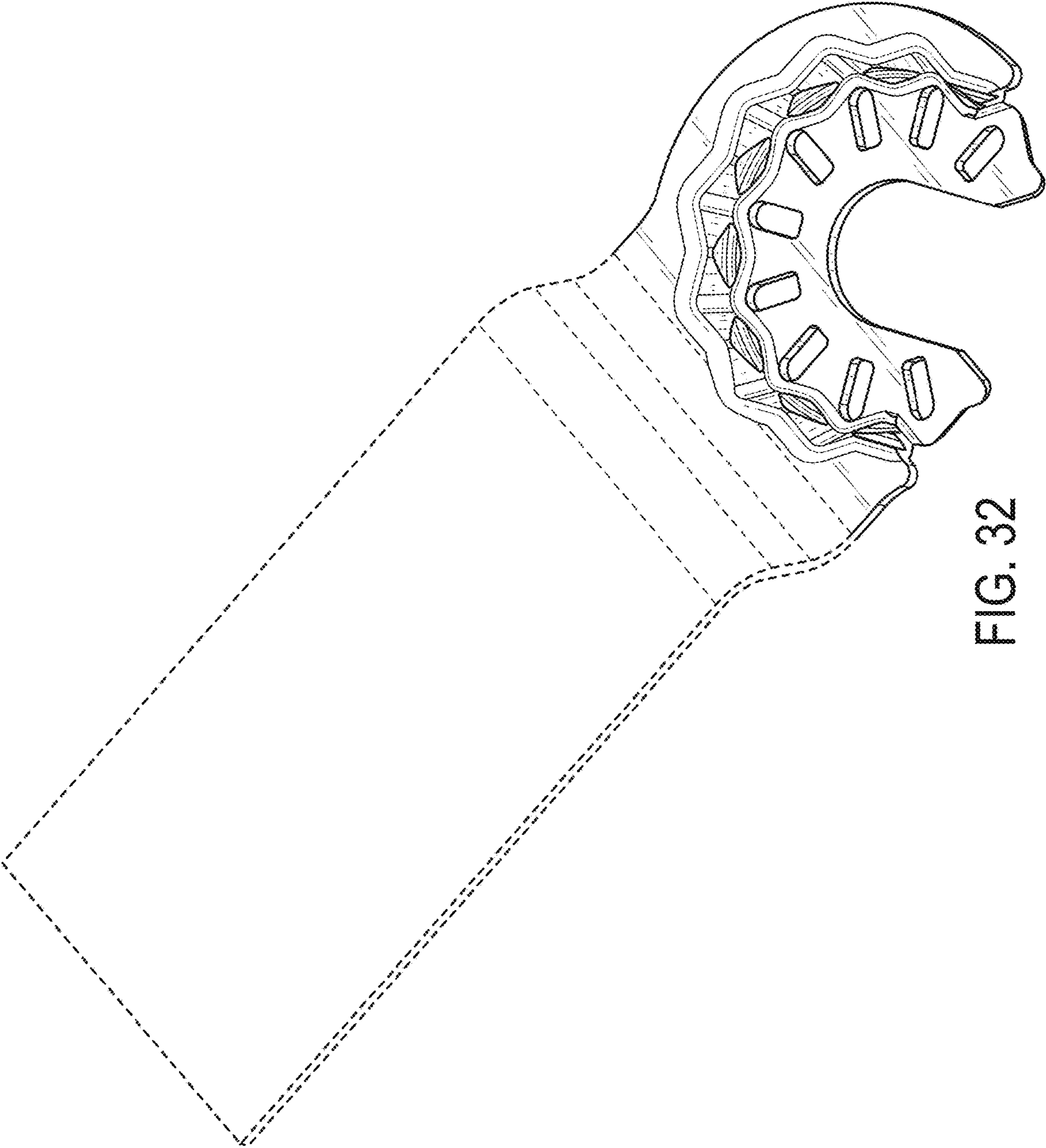

FIG. 32

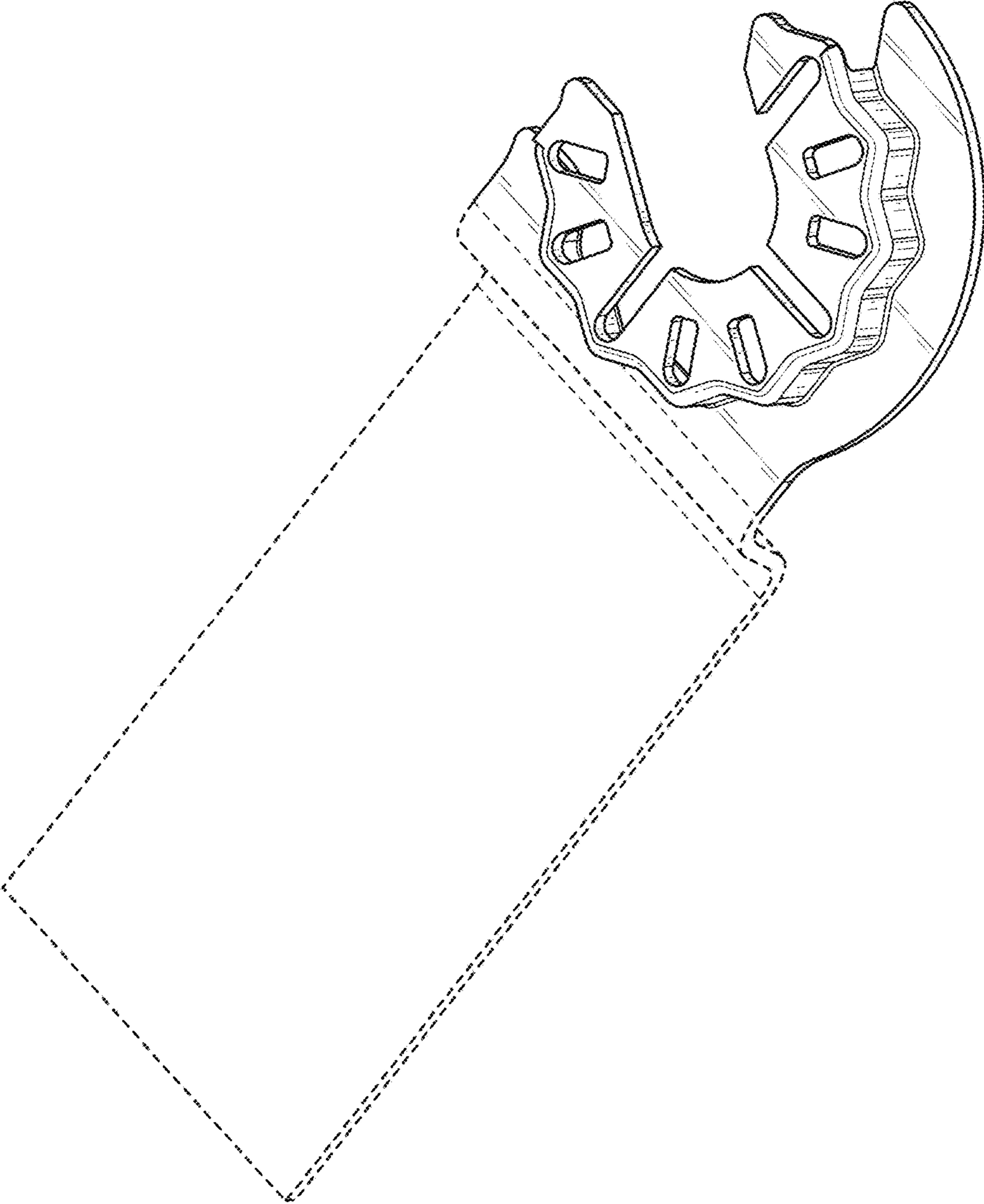

FIG. 33

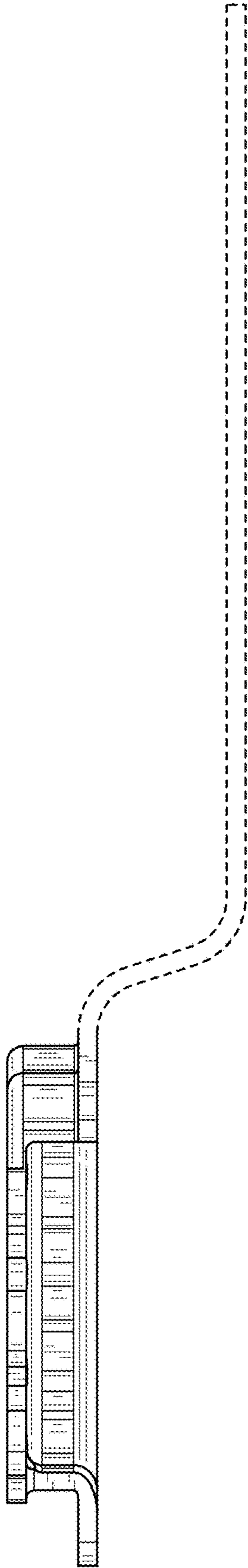

FIG. 34

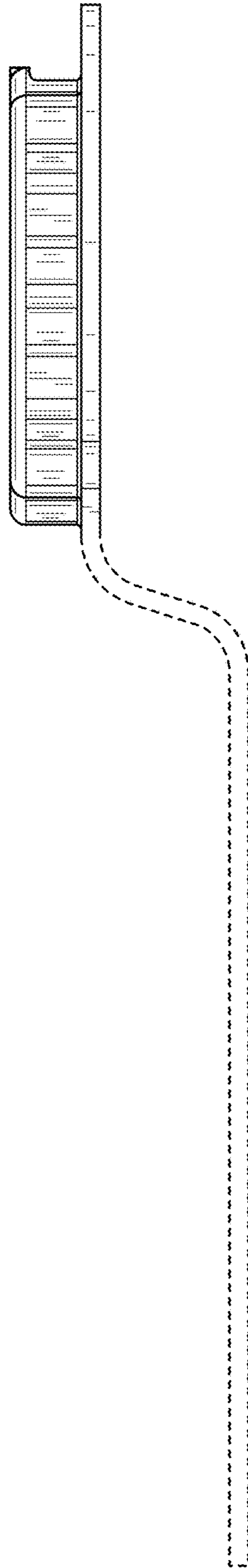

FIG. 35

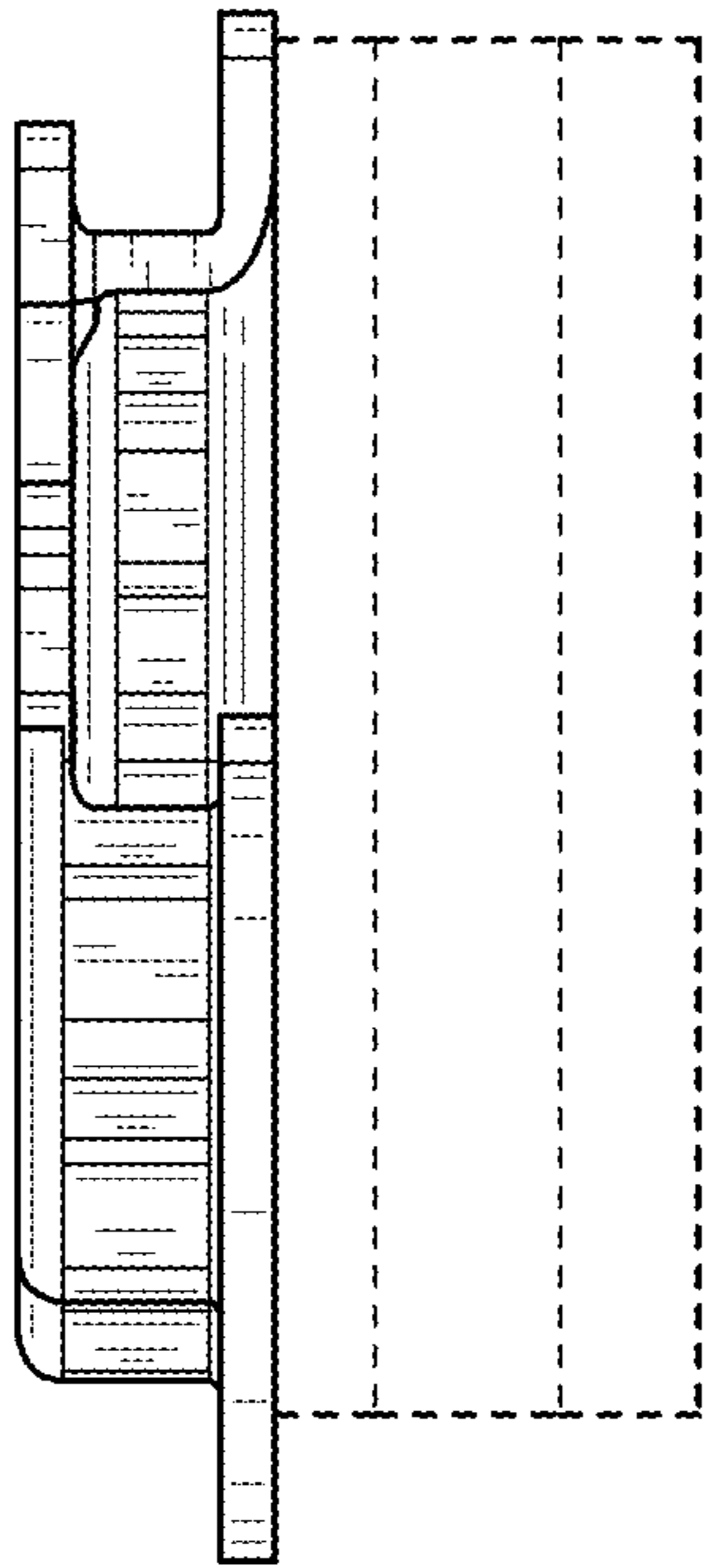

FIG. 36

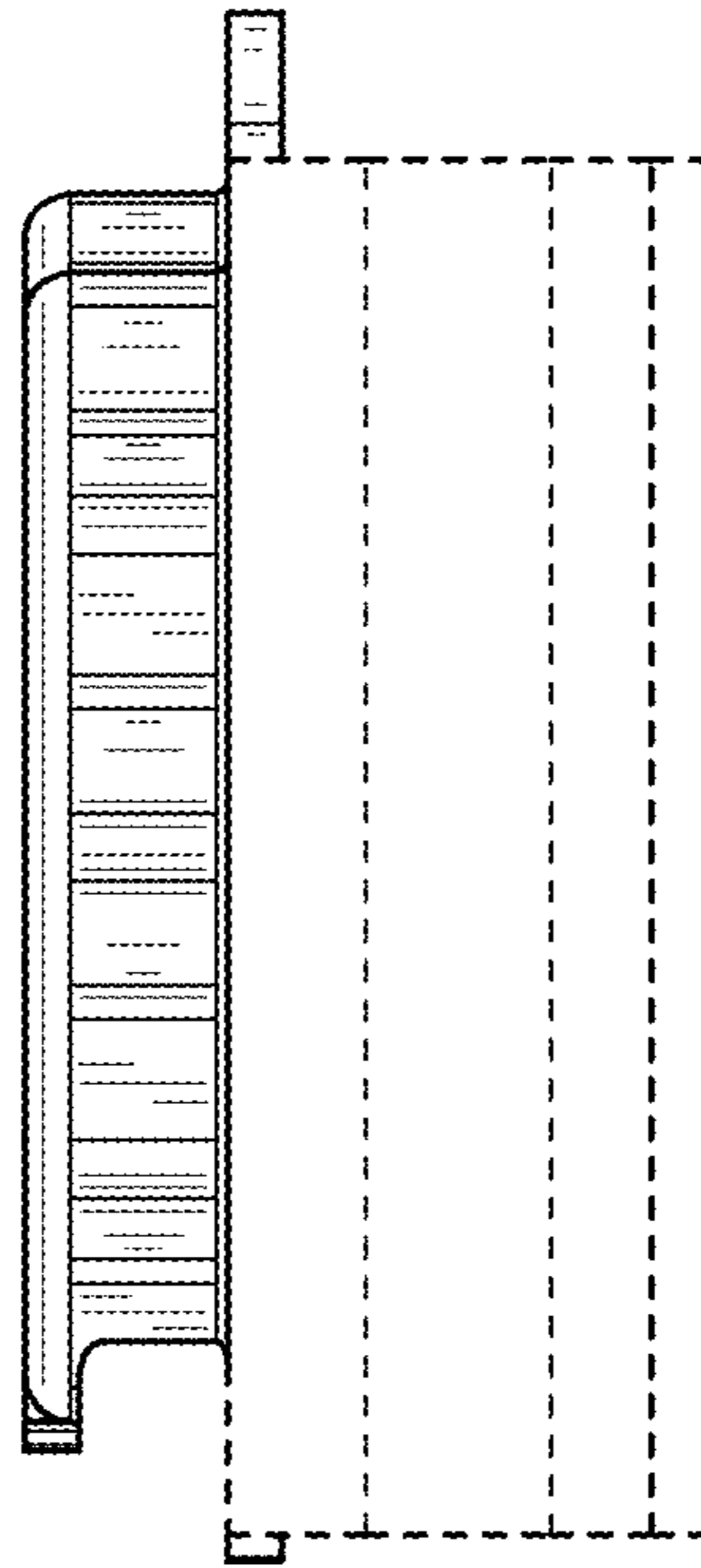

FIG. 37

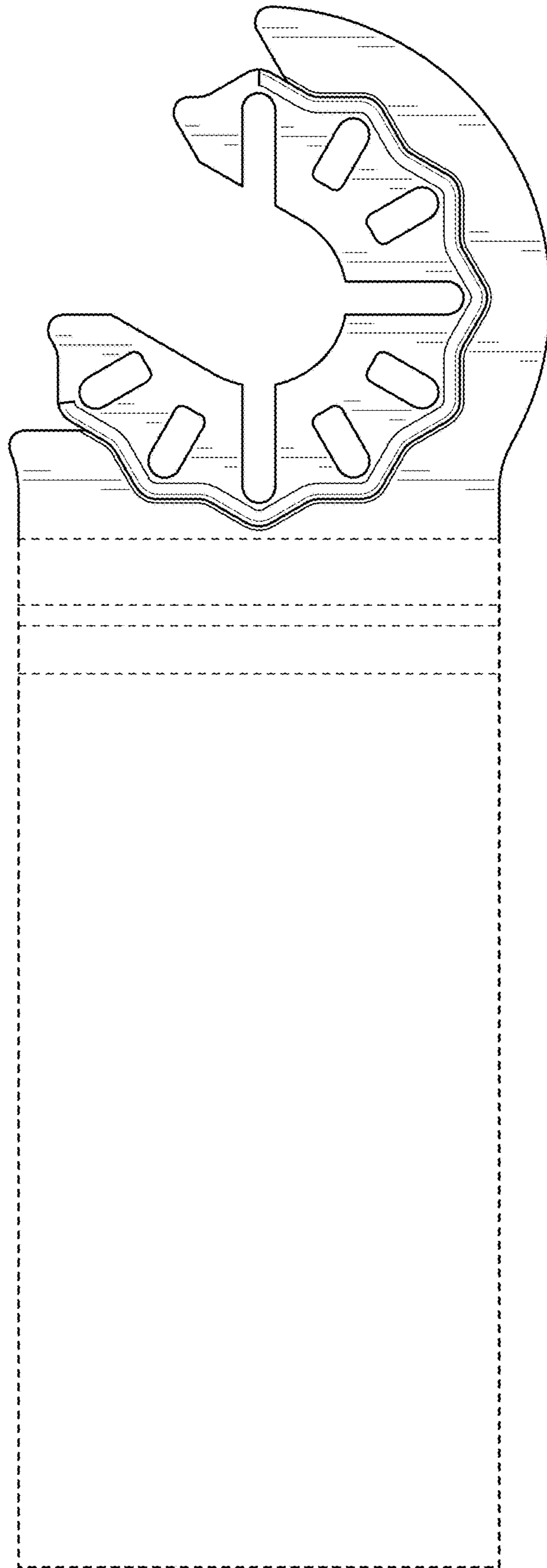

FIG. 38

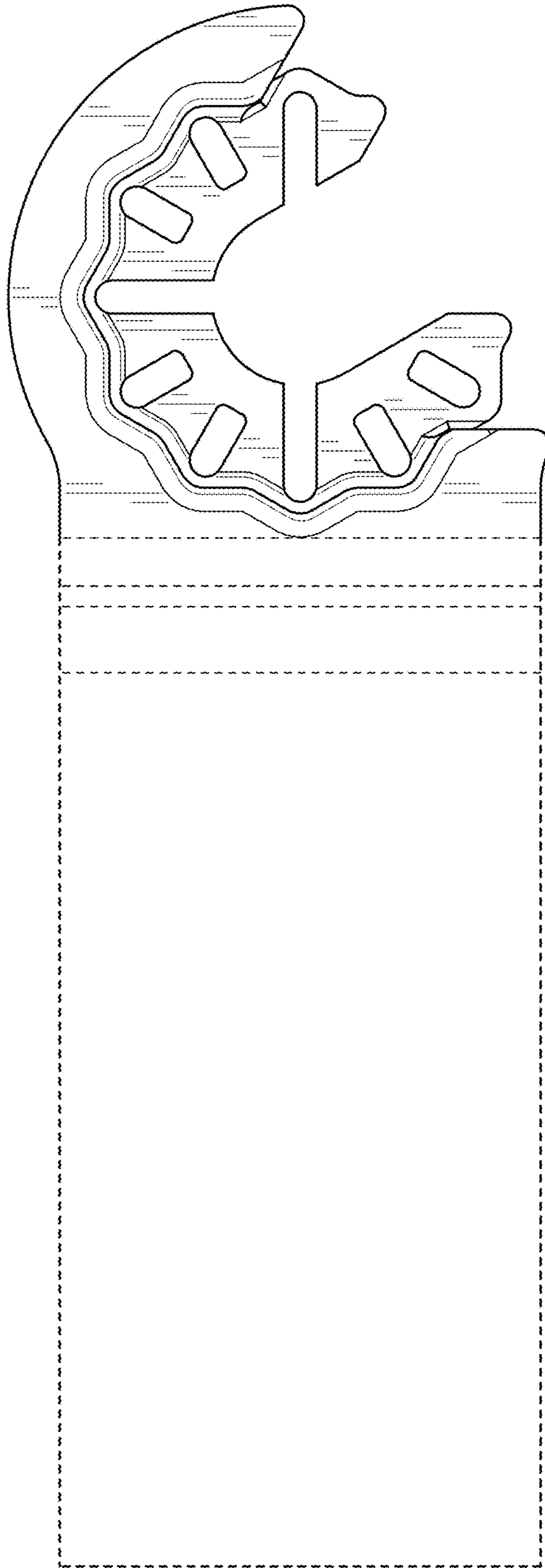

FIG. 39

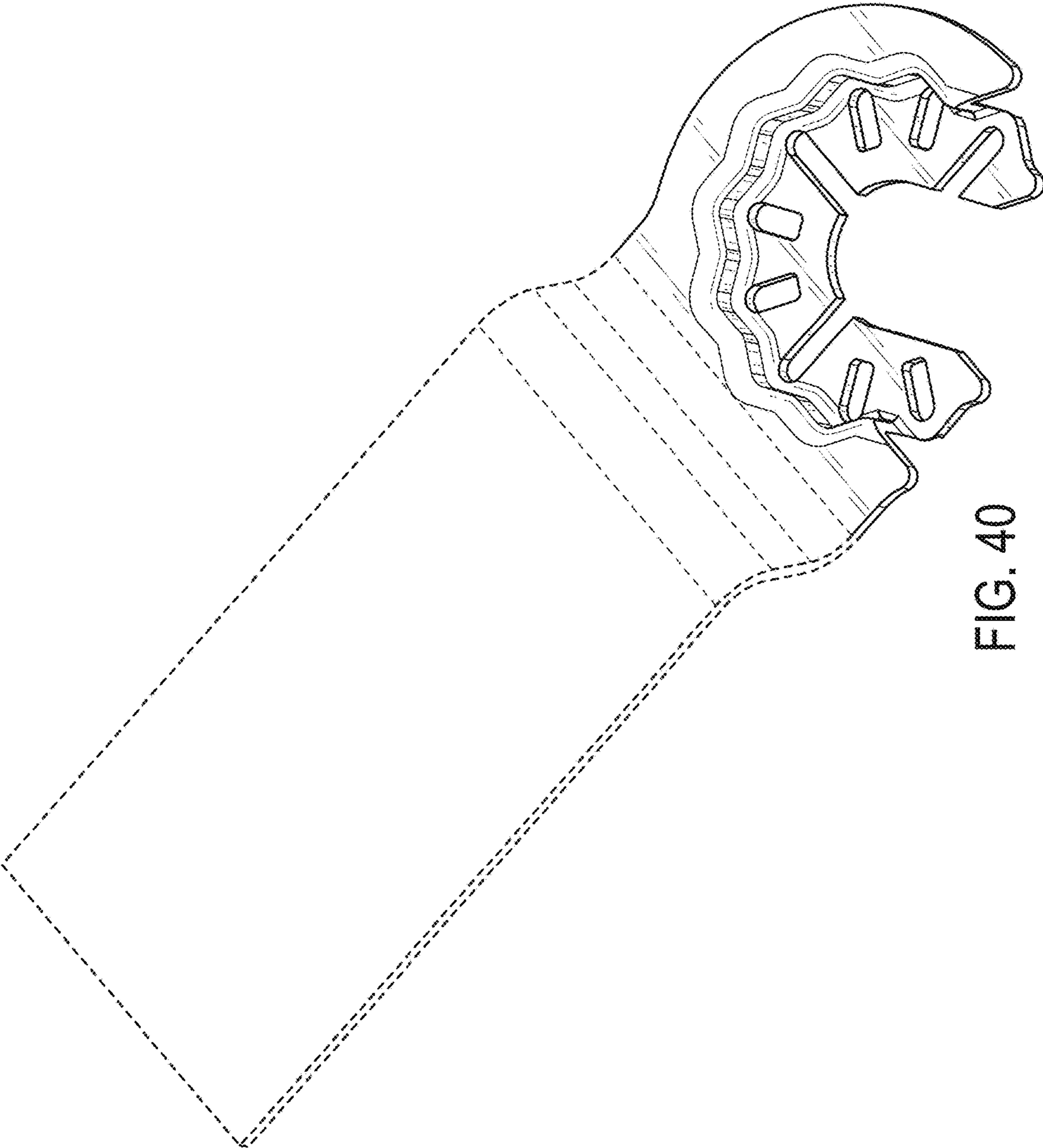

FIG. 40

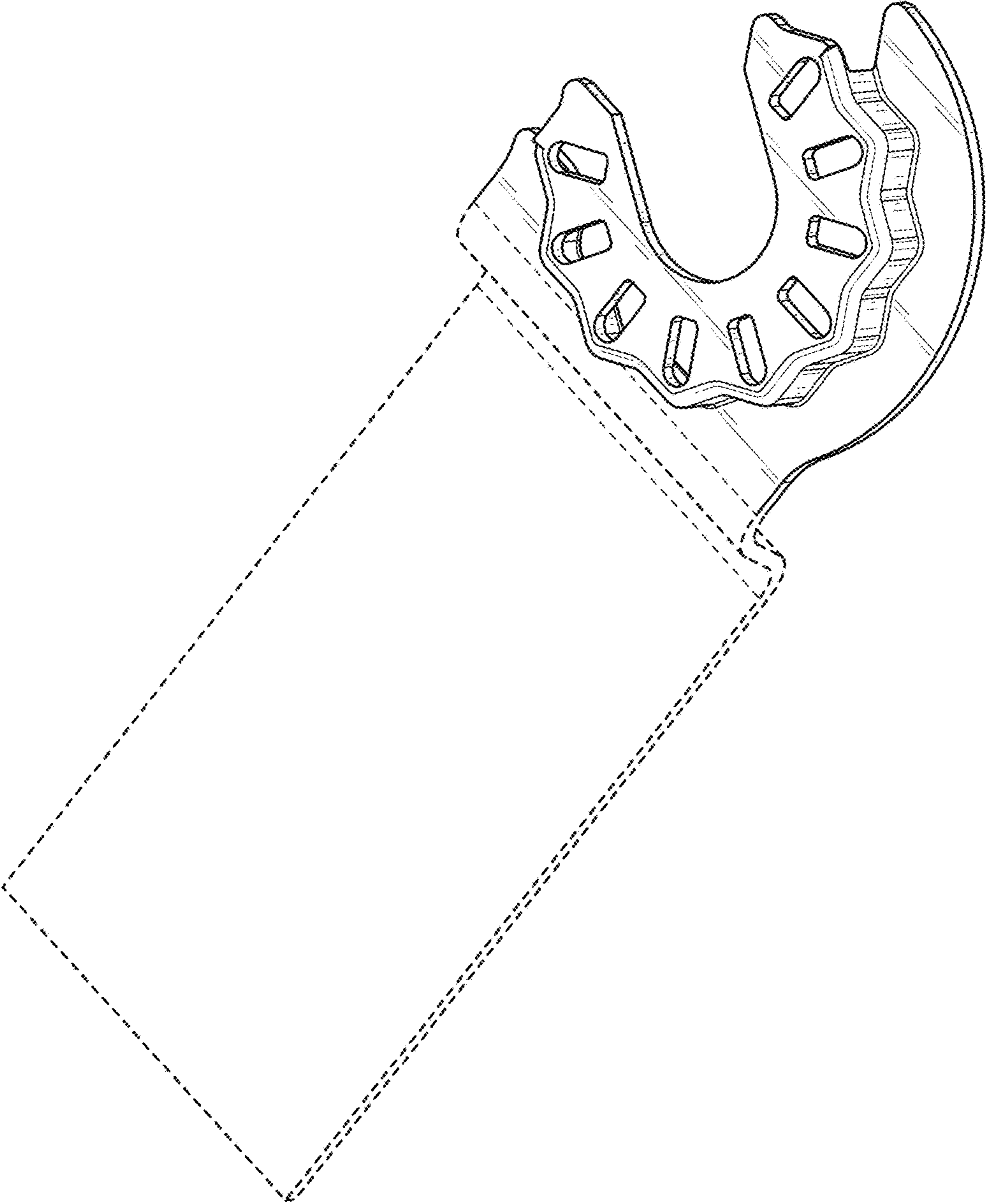

FIG. 41

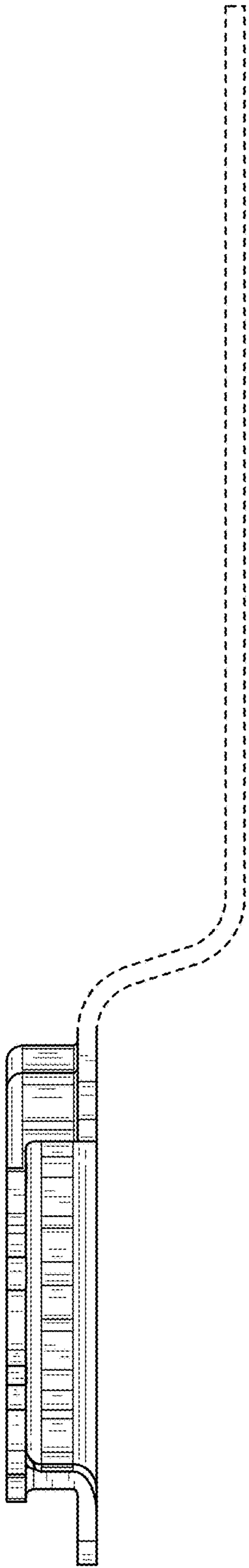

FIG. 42



FIG. 43

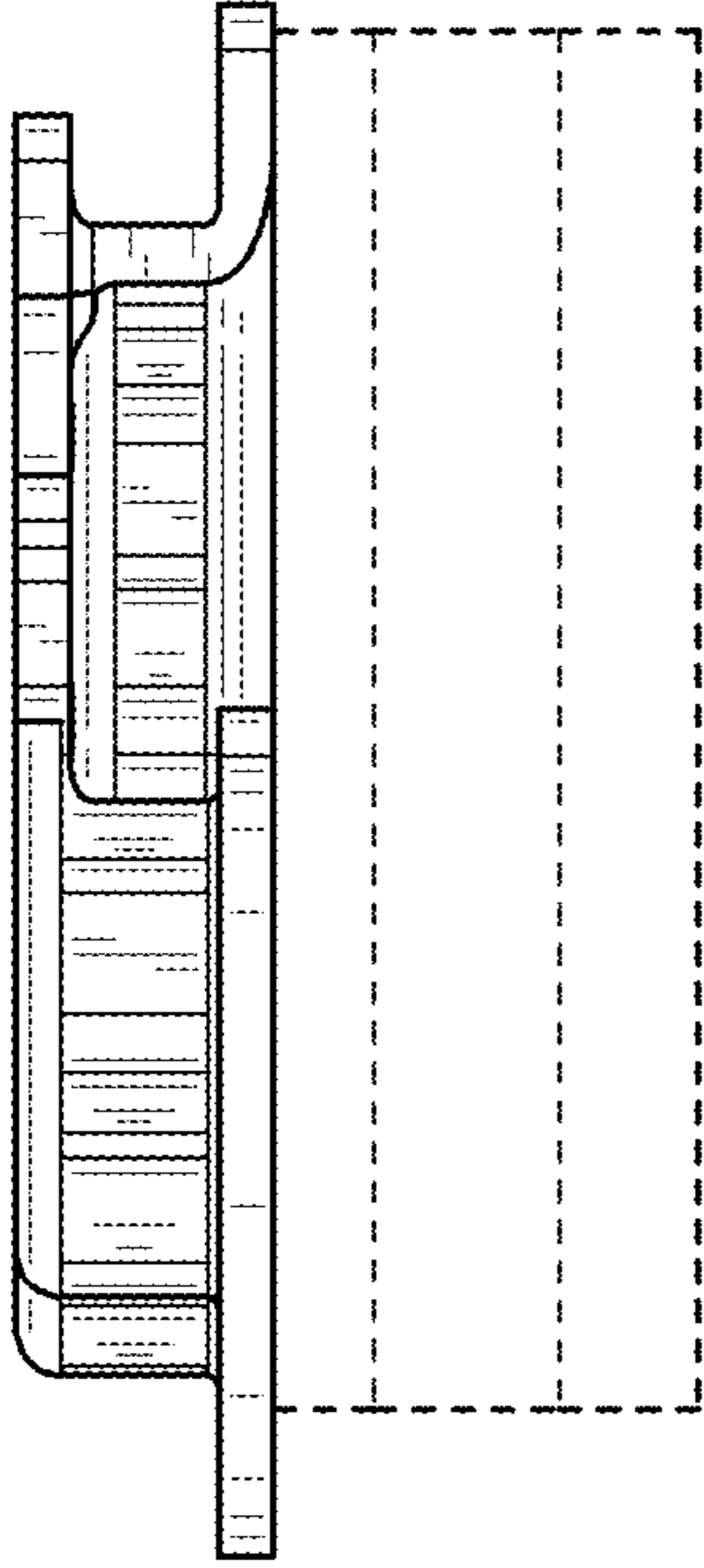

FIG. 44

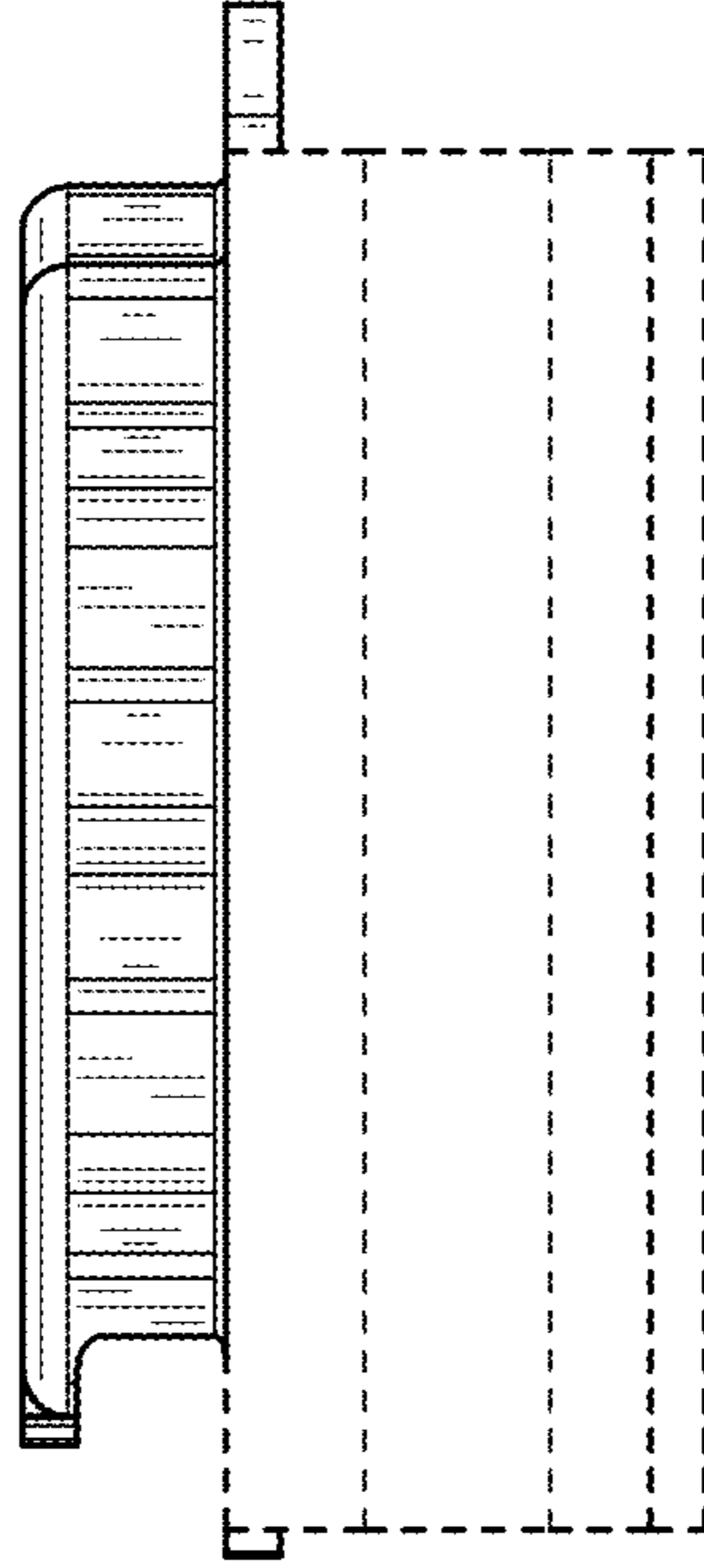

FIG. 45

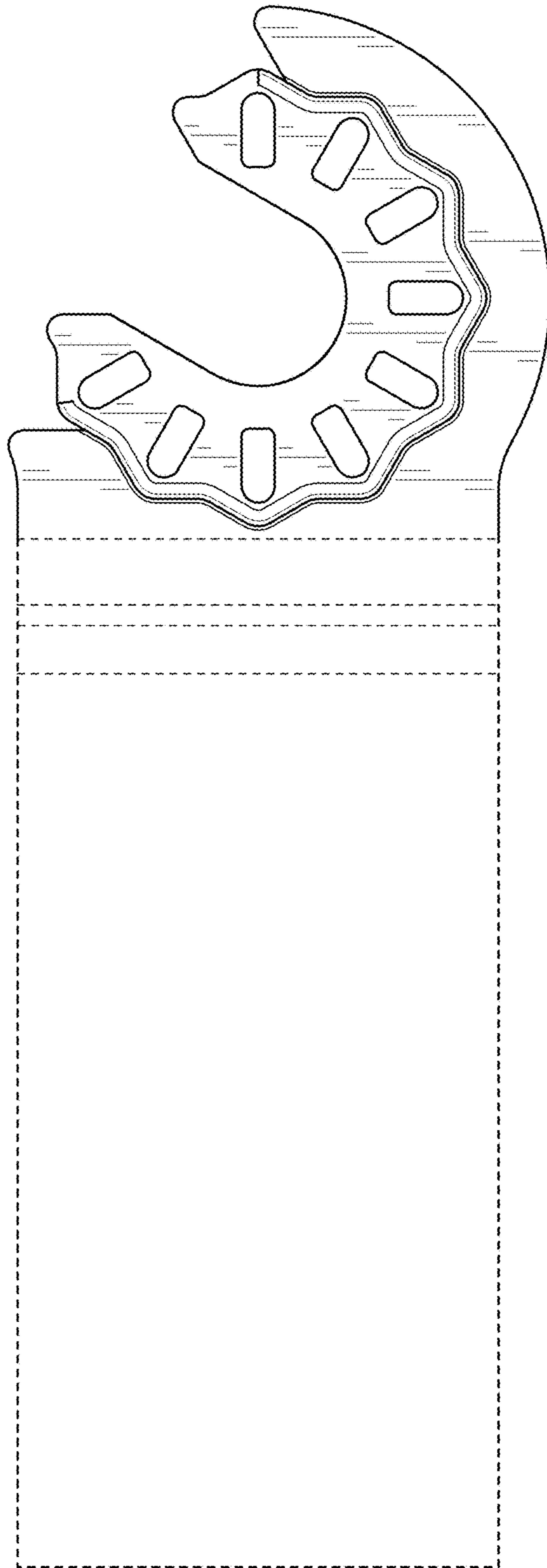

FIG. 46

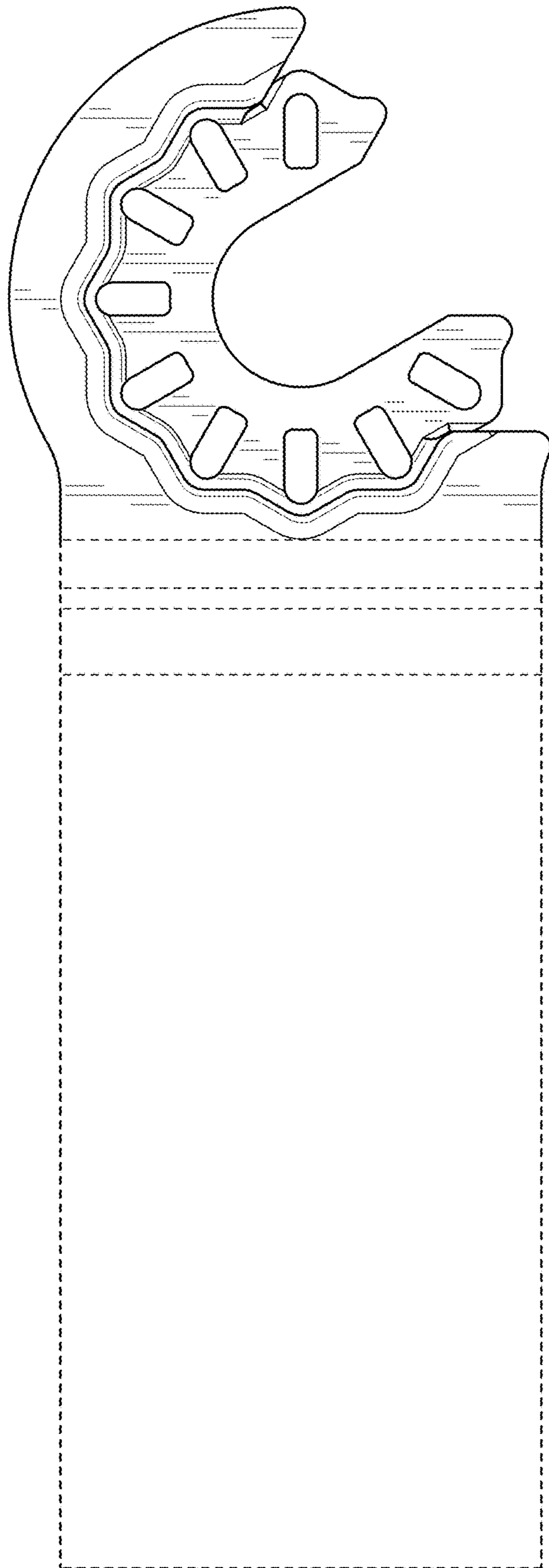

FIG. 47

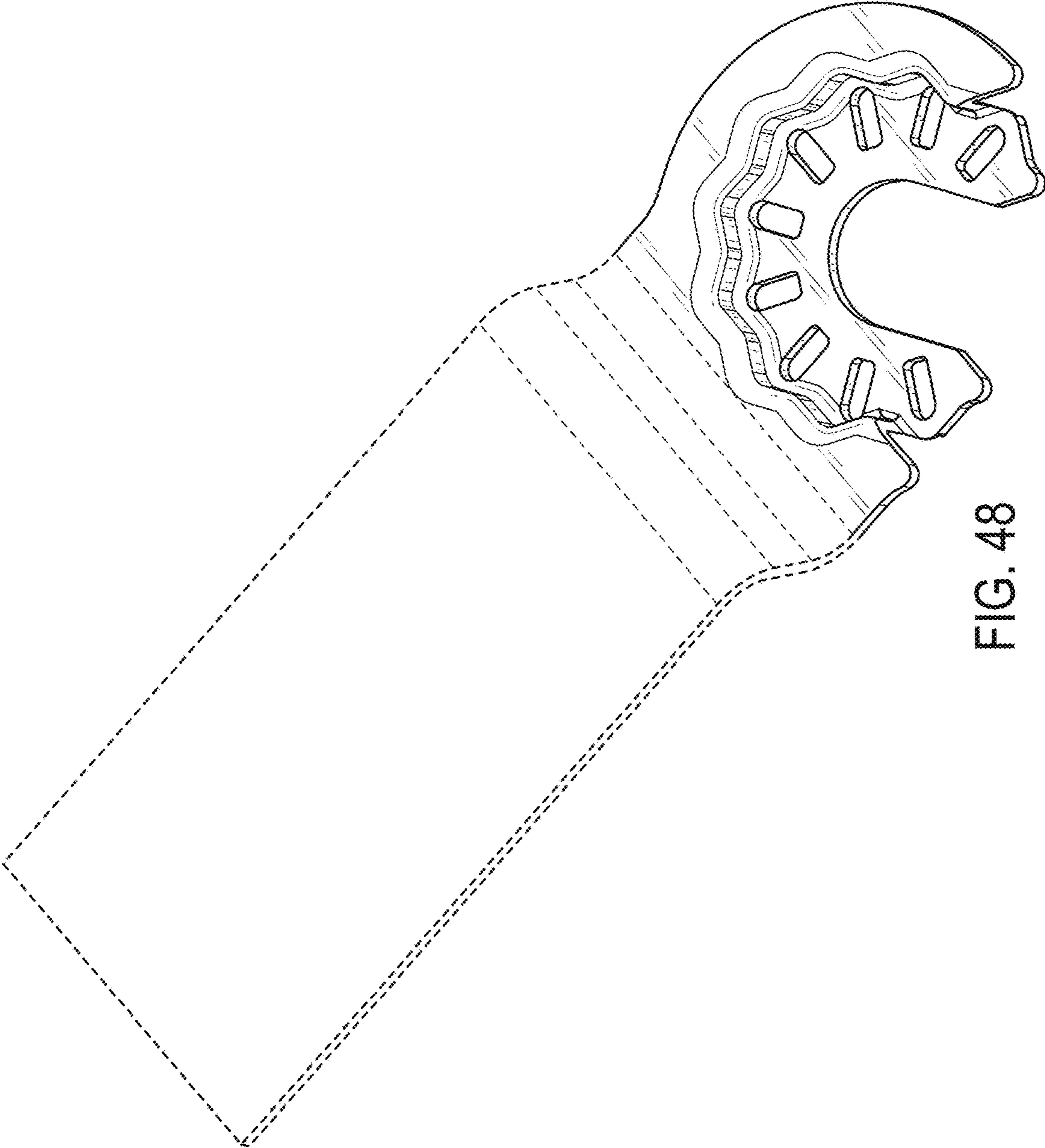

FIG. 48

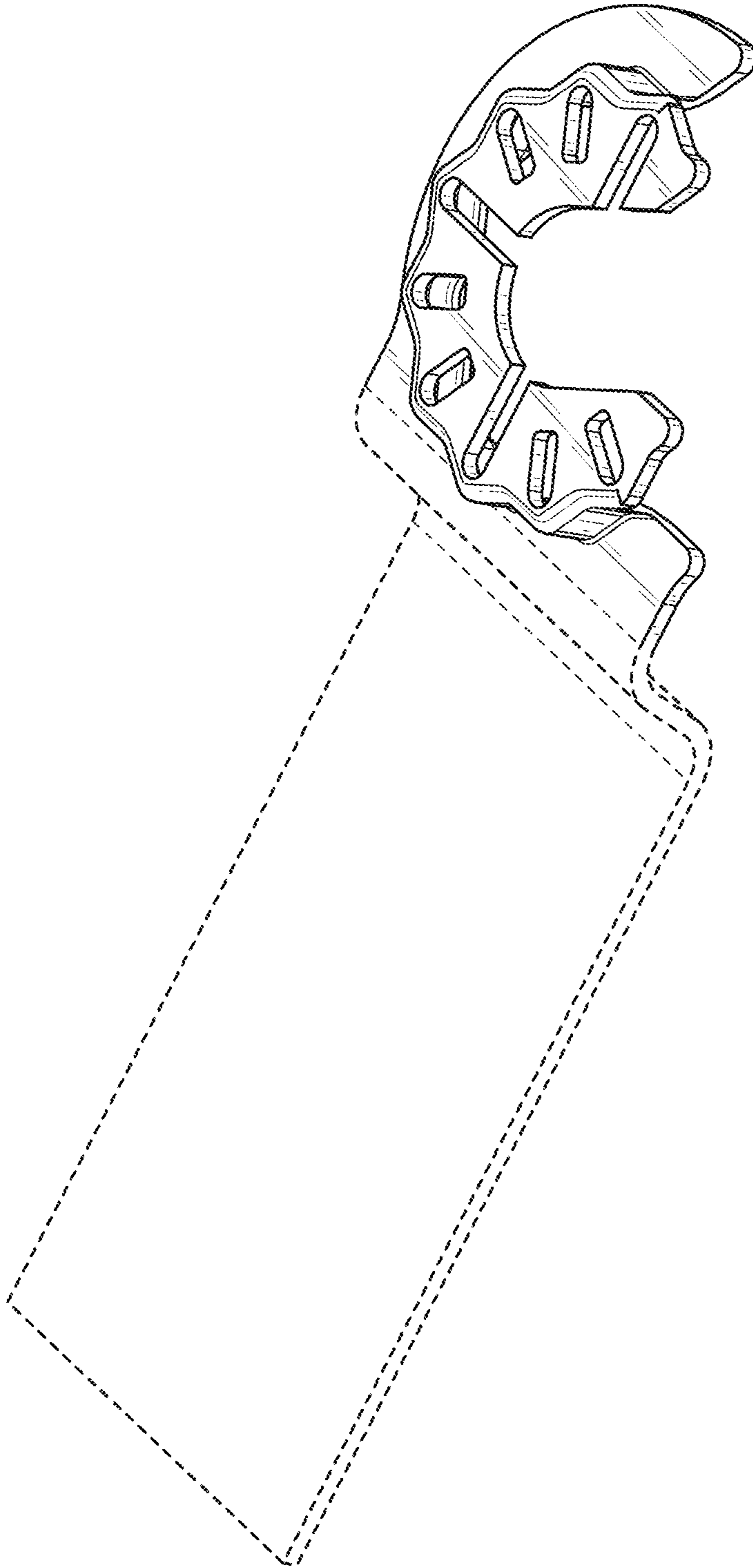

FIG. 49

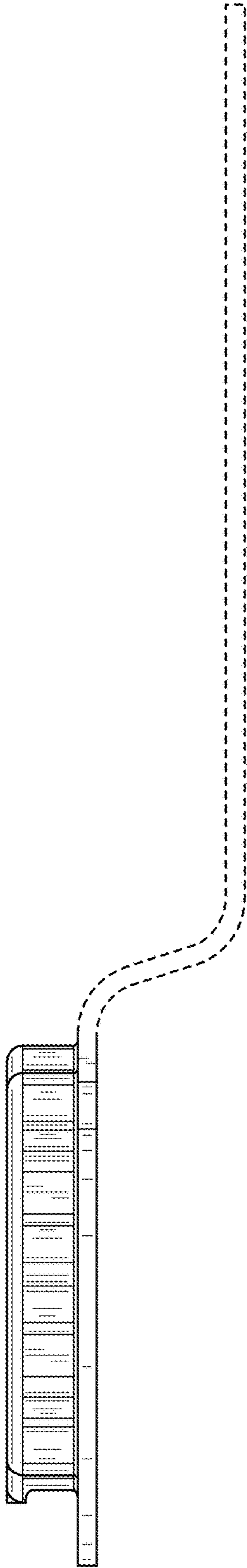

FIG. 50

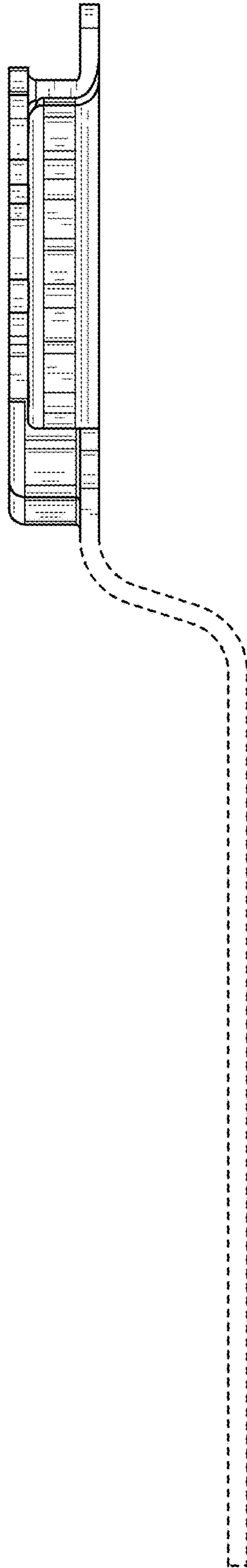

FIG. 51

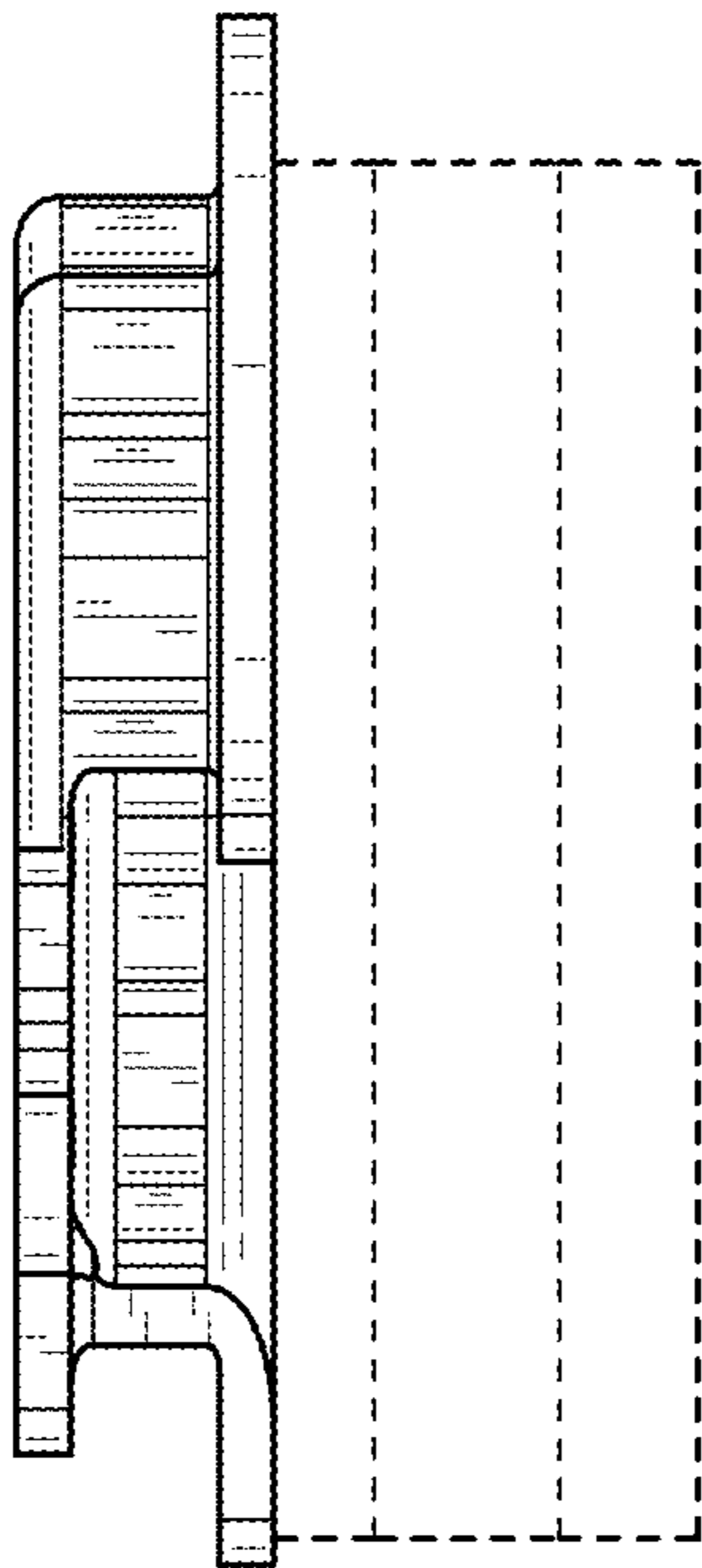

FIG. 52

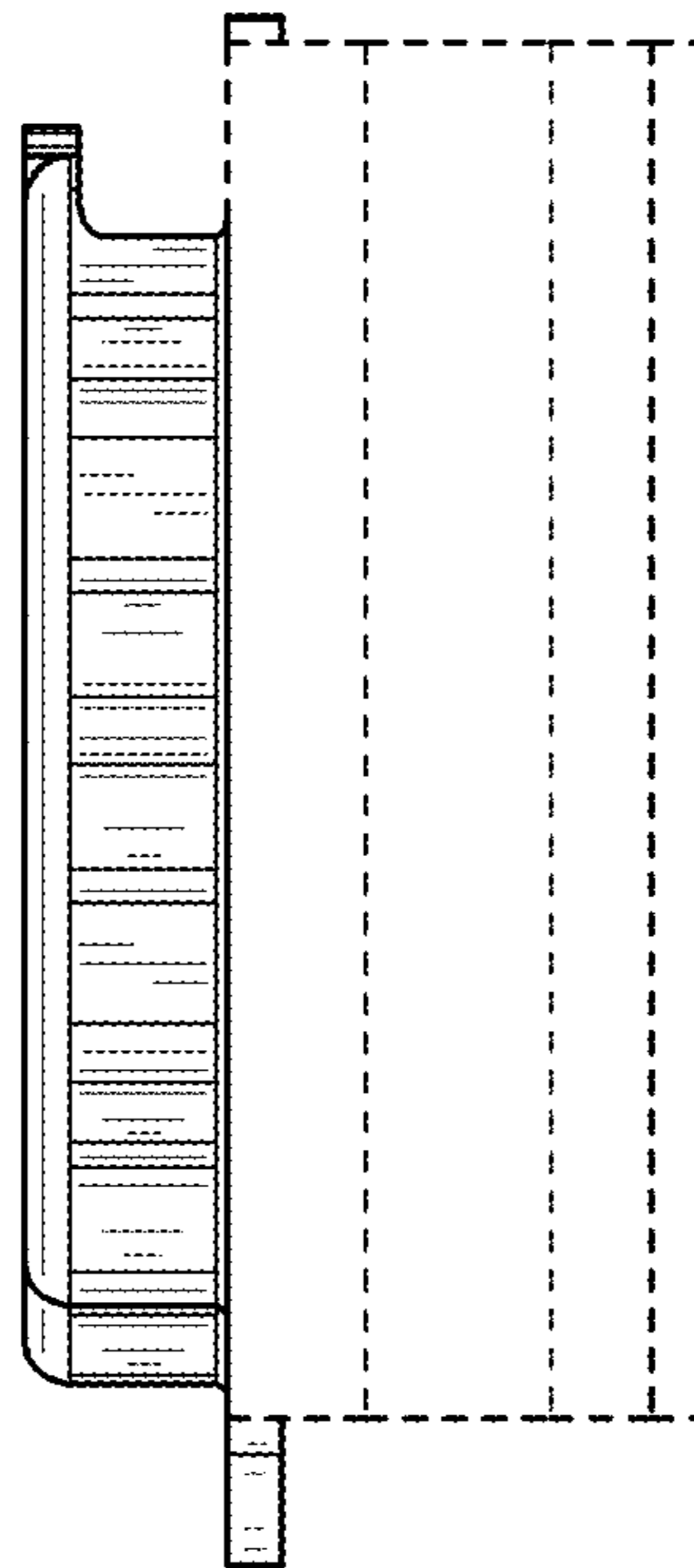

FIG. 53

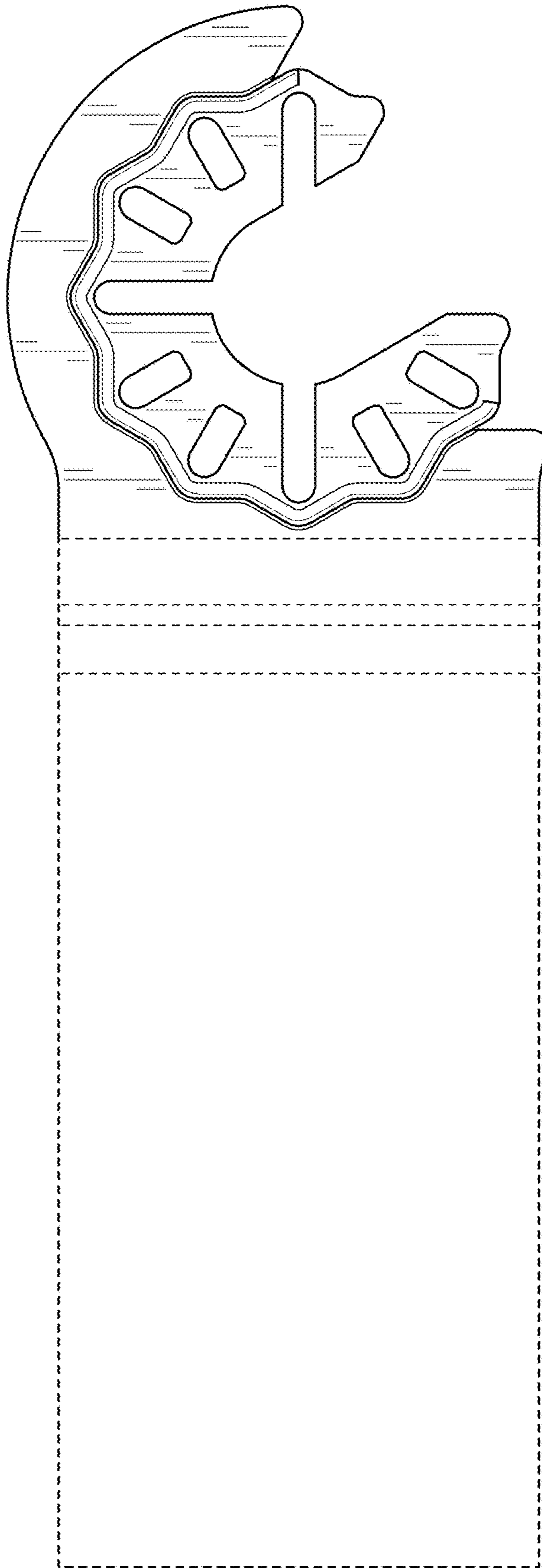

FIG. 54

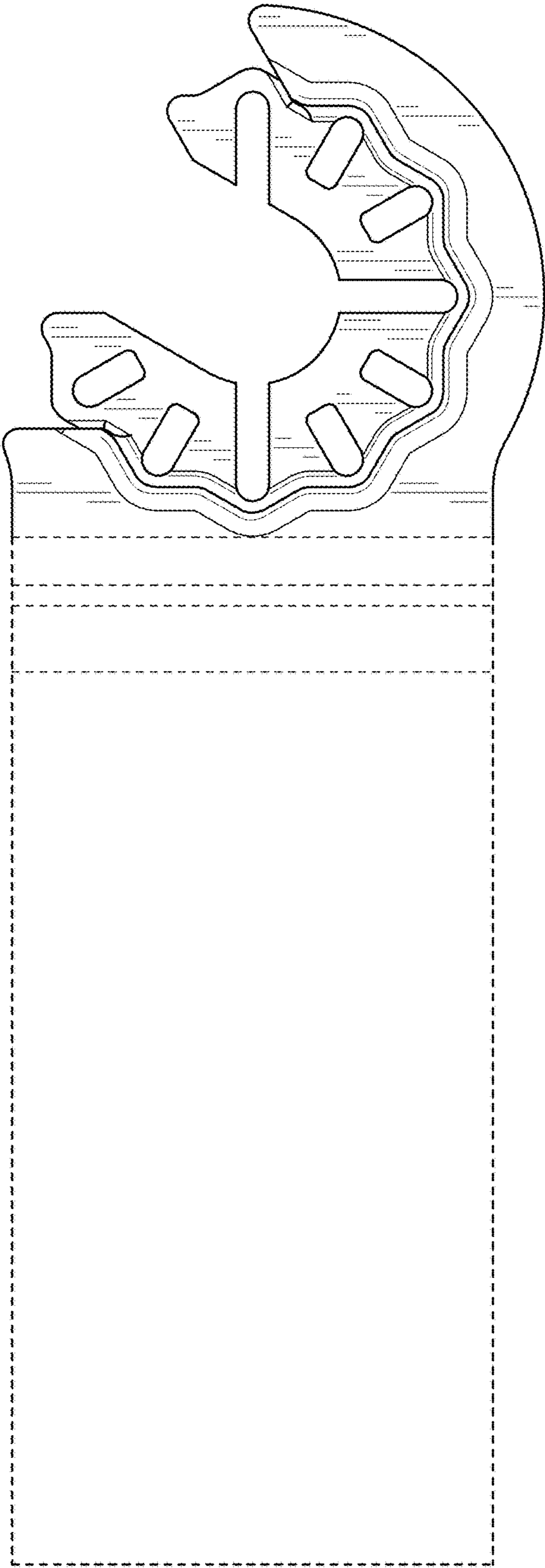

FIG. 55

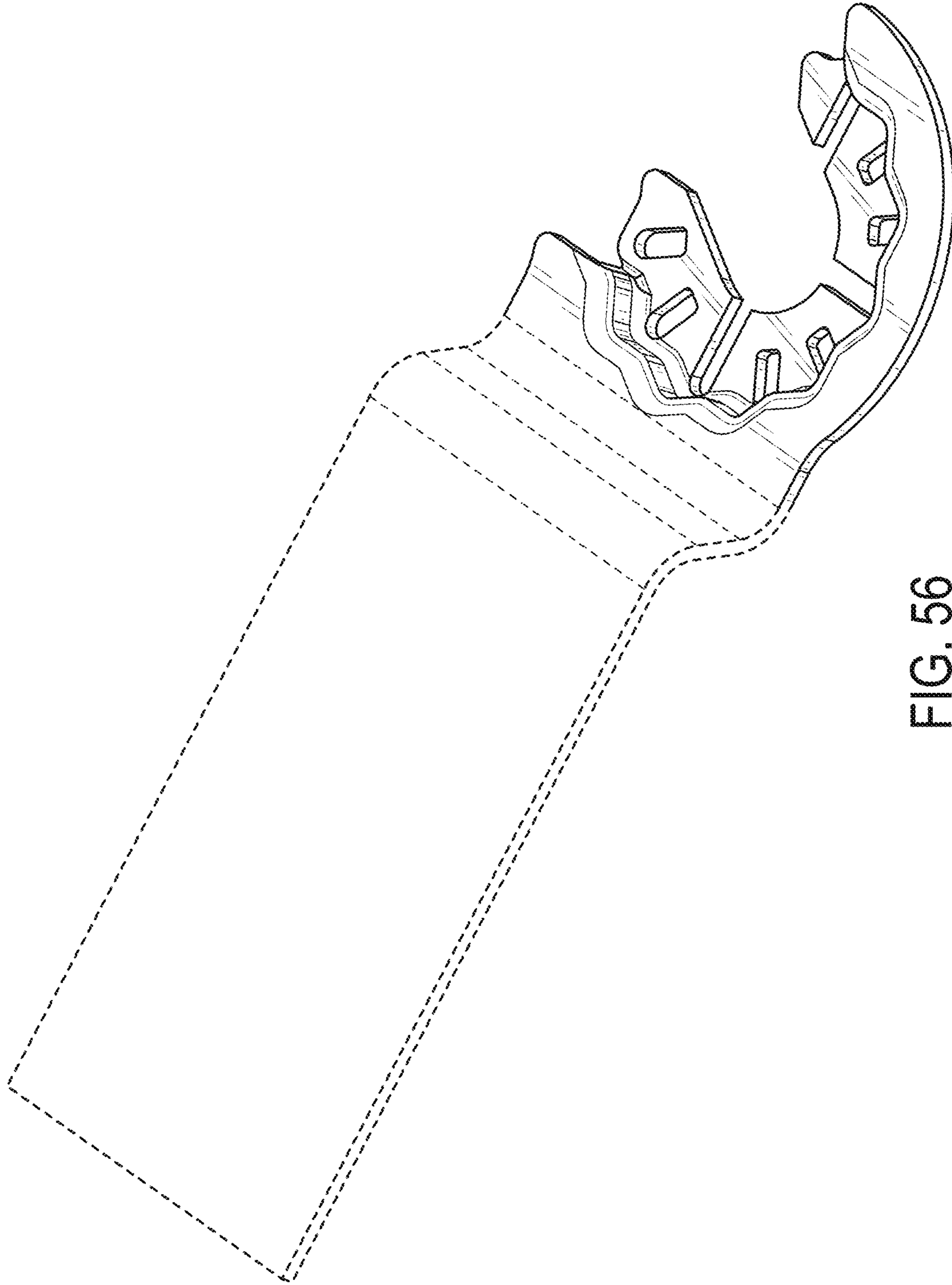

FIG. 56

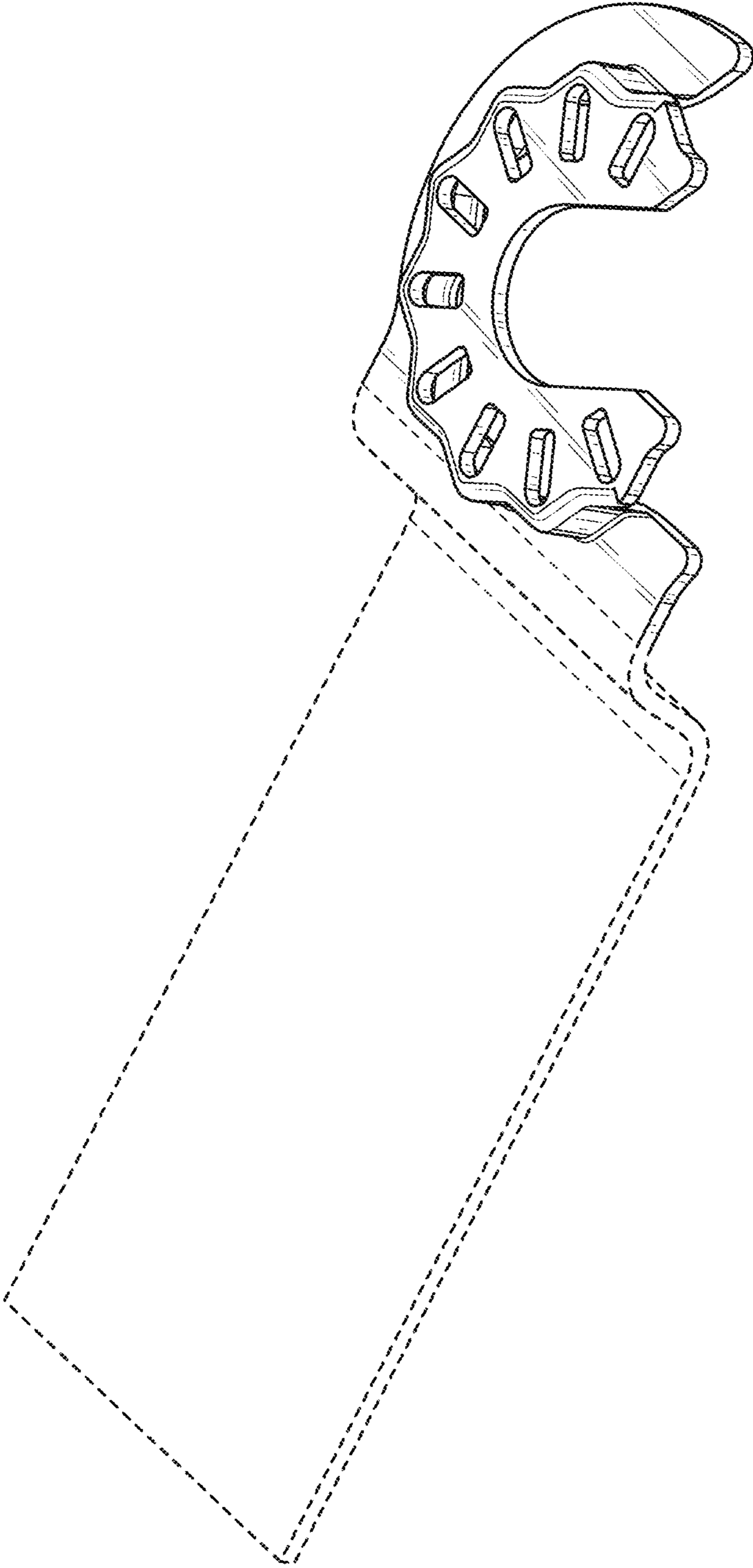

FIG. 57



FIG. 58

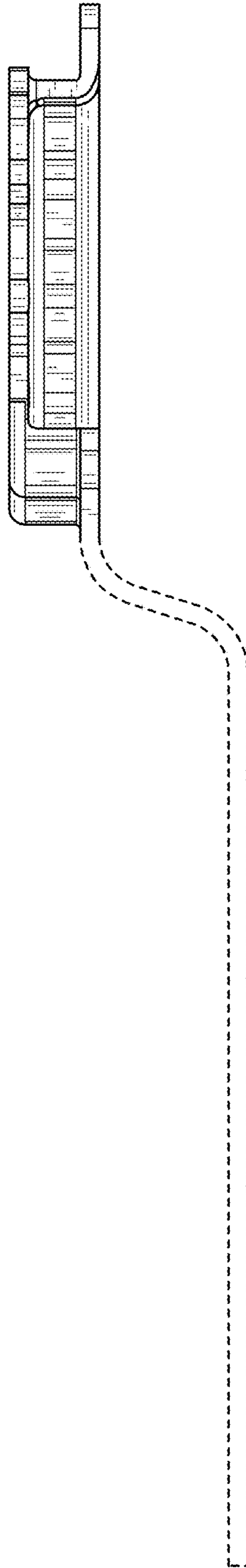

FIG. 59

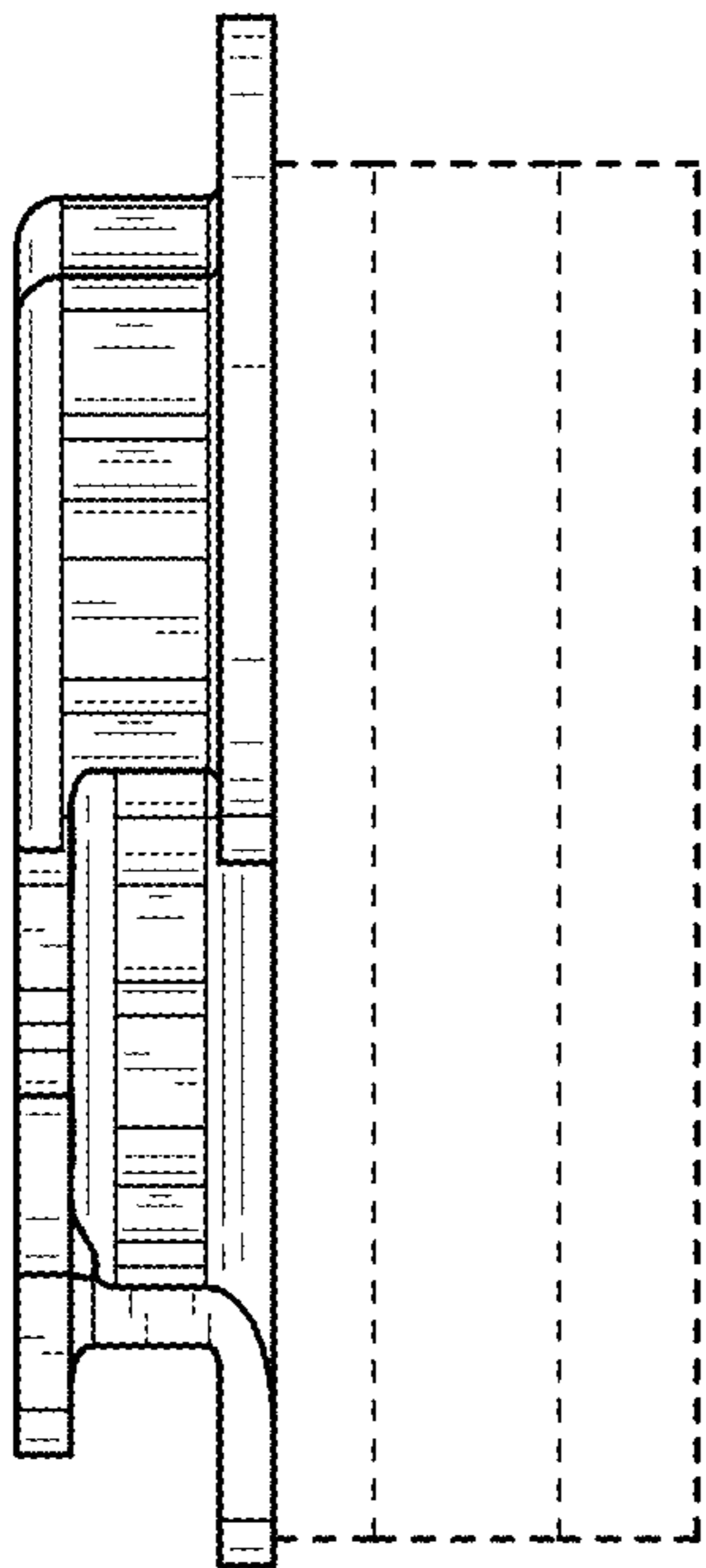

FIG. 60

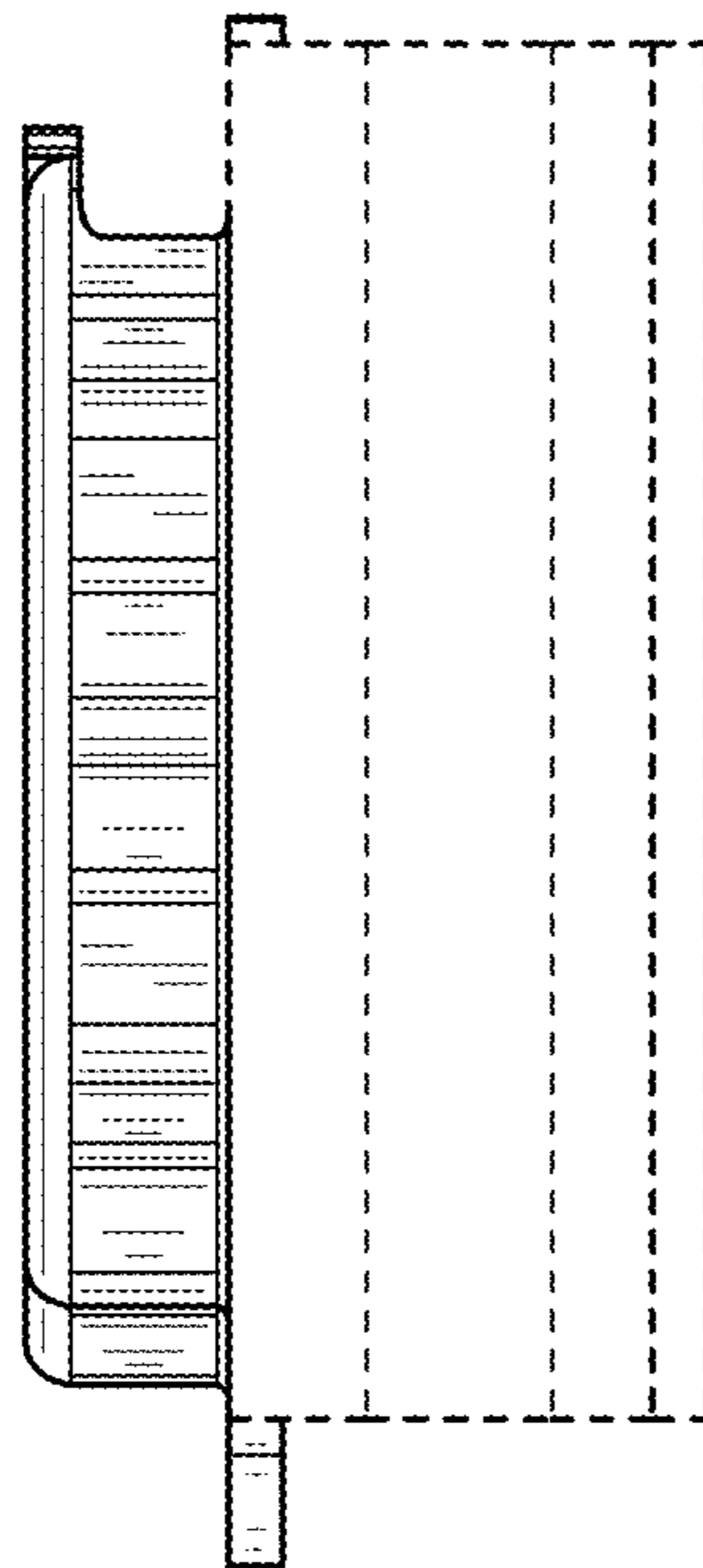

FIG. 61

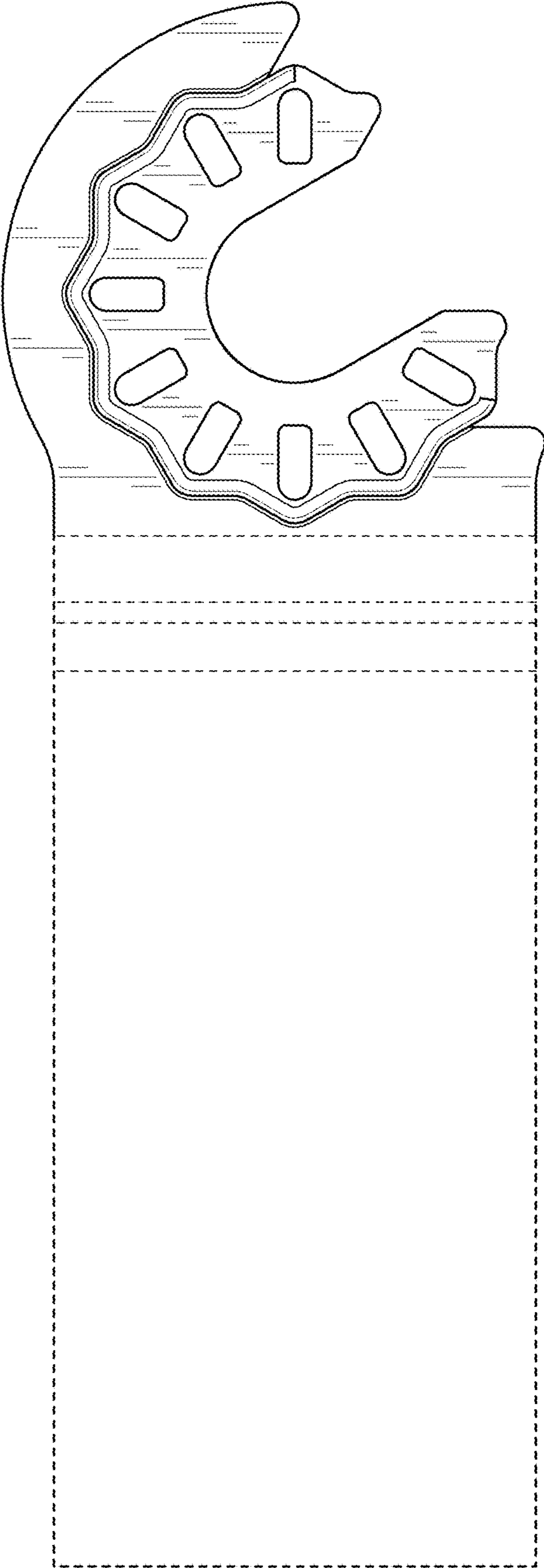

FIG. 62

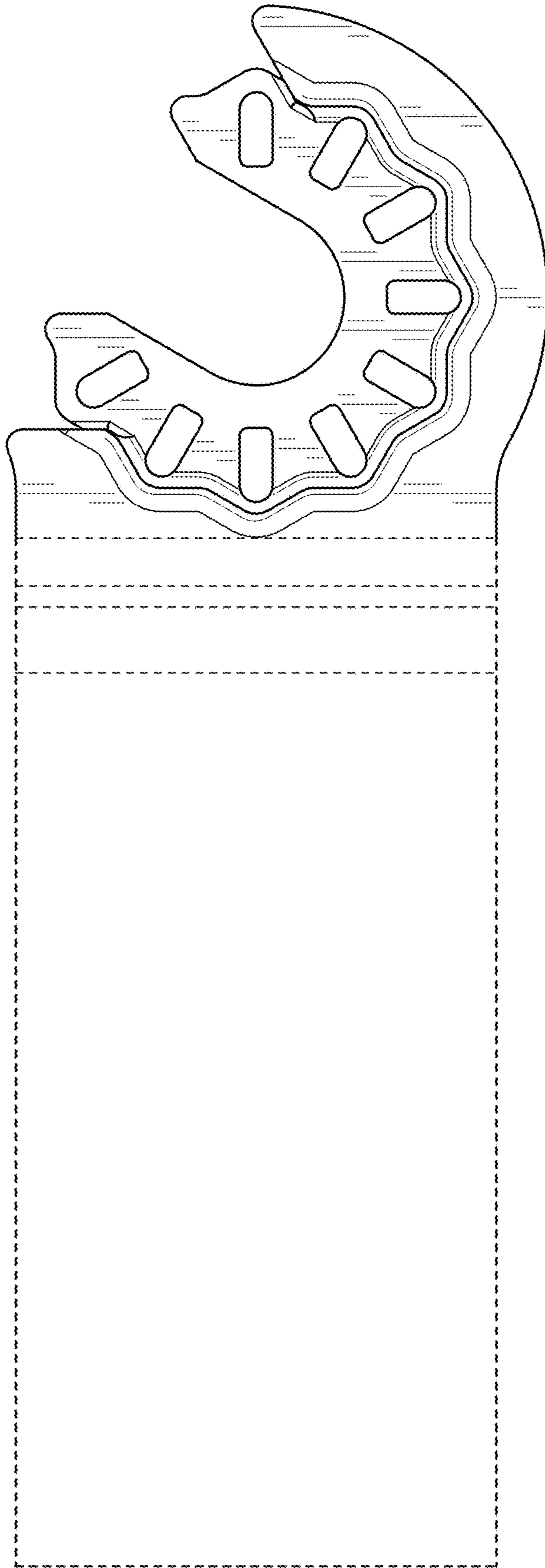

FIG. 63

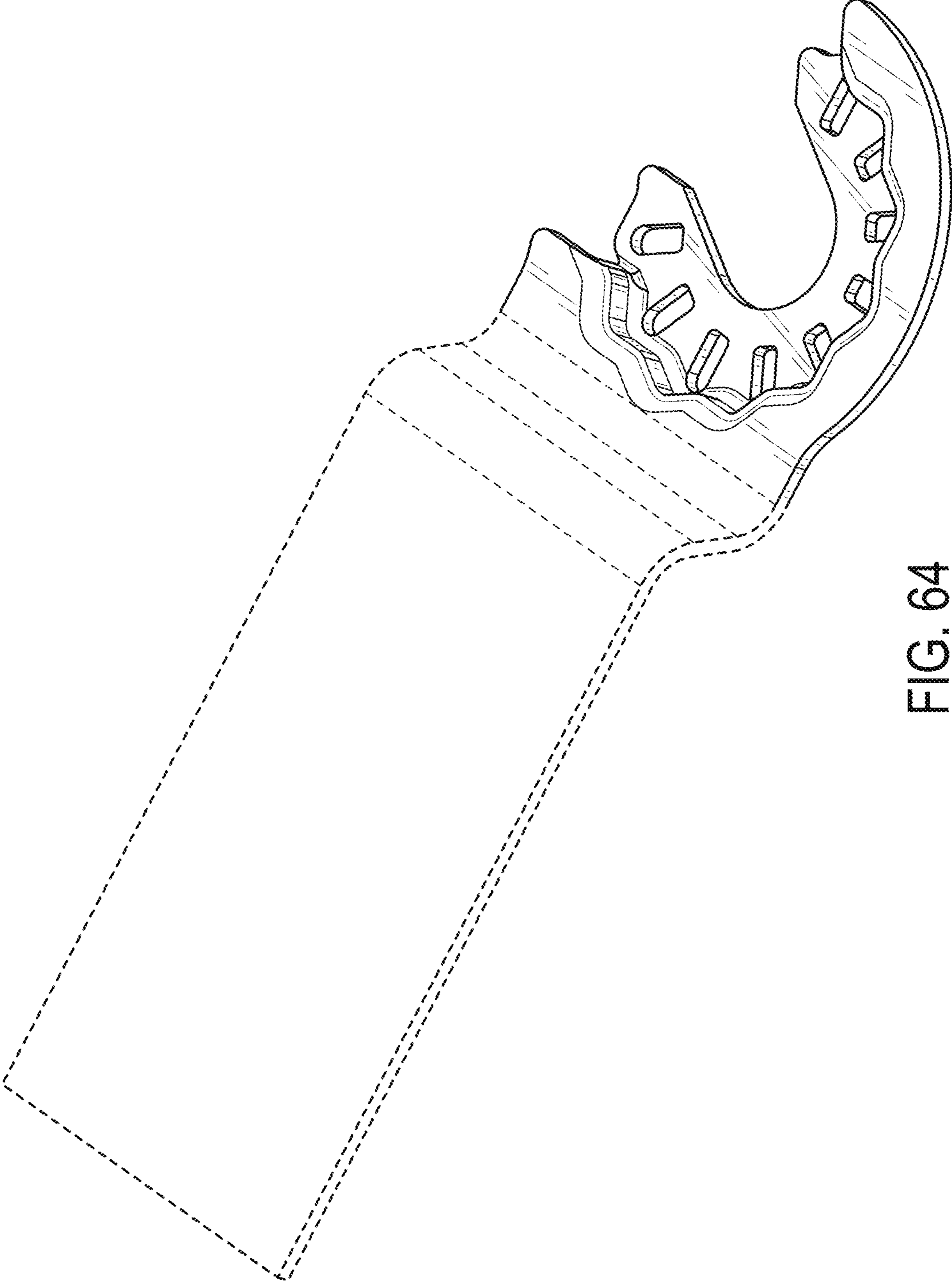

FIG. 64