



US00D814628S

(12) **United States Design Patent**
Longmuir

(10) **Patent No.:** **US D814,628 S**
(45) **Date of Patent:** **** *Apr. 3, 2018**

(54) **CONDOM**

(71) Applicant: **Shona Longmuir**, Irvine (GB)

(72) Inventor: **Shona Longmuir**, Irvine (GB)

(*) Notice: This patent is subject to a terminal disclaimer.

(**) Term: **14 Years**

(21) Appl. No.: **29/509,490**

(22) Filed: **Nov. 18, 2014**

(51) **LOC (11) Cl.** **24-04**

(52) **U.S. Cl.**
USPC **D24/105**

(58) **Field of Classification Search**
USPC D24/105, 106, 211, 215; D7/300.2;
D8/303; D20/16; D21/440; D27/101
(Continued)

(56) **References Cited**

U.S. PATENT DOCUMENTS

D57,978 S * 5/1921 Kavan D20/16
1,875,049 A * 8/1932 Lewis G09F 23/16
40/430

(Continued)

FOREIGN PATENT DOCUMENTS

EM 002350355 11/2013

Primary Examiner — Richelle G Shelton

(74) *Attorney, Agent, or Firm* — Fross Zelnick Lehrman & Zissu P.C.; Charles T. J. Weigell, Esq.

(57) **CLAIM**

The ornamental design for a condom, as shown and described.

DESCRIPTION

The patent or application file contains at least one drawing executed in color. Copies of this patent or patent application

publication with color drawings(s) will be provided by the Office upon request and payment of the necessary fee.

FIG. 1 is a front perspective view of a condom showing my new design;

FIG. 2 is a front view thereof;

FIG. 3 is a rear view thereof

FIG. 4 is a bottom view thereof;

FIG. 5 is a front perspective view of a second embodiment of the condom

FIG. 6 is a front view thereof;

FIG. 7 is a rear view thereof;

FIG. 8 is a bottom view thereof;

FIG. 9 is a front perspective view of a third embodiment of the condom

FIG. 10 is a front view thereof;

FIG. 11 is a rear view thereof

FIG. 12 is a bottom view thereof;

FIG. 13 is a front perspective view of a fourth embodiment of the condom

FIG. 14 is a front view thereof;

FIG. 15 is a rear view thereof

FIG. 16 is a bottom view thereof;

FIG. 17 is a front perspective view of a fifth embodiment of the condom

FIG. 18 is a front view thereof;

FIG. 19 is a rear view thereof

FIG. 20 is a bottom view thereof;

FIG. 21 is a front perspective view of a sixth embodiment of the condom

FIG. 22 is a front view thereof;

FIG. 23 is a rear view thereof

FIG. 24 is a bottom view thereof;

FIG. 25 is a front perspective view of a seventh embodiment of the condom

FIG. 26 is a front view thereof;

FIG. 27 is a rear view thereof

FIG. 28 is a bottom view thereof;

FIG. 29 is a front perspective view of an eight embodiment of the condom

FIG. 30 is a front view thereof;

FIG. 31 is a rear view thereof; and,

FIG. 32 is a bottom view thereof.

(Continued)

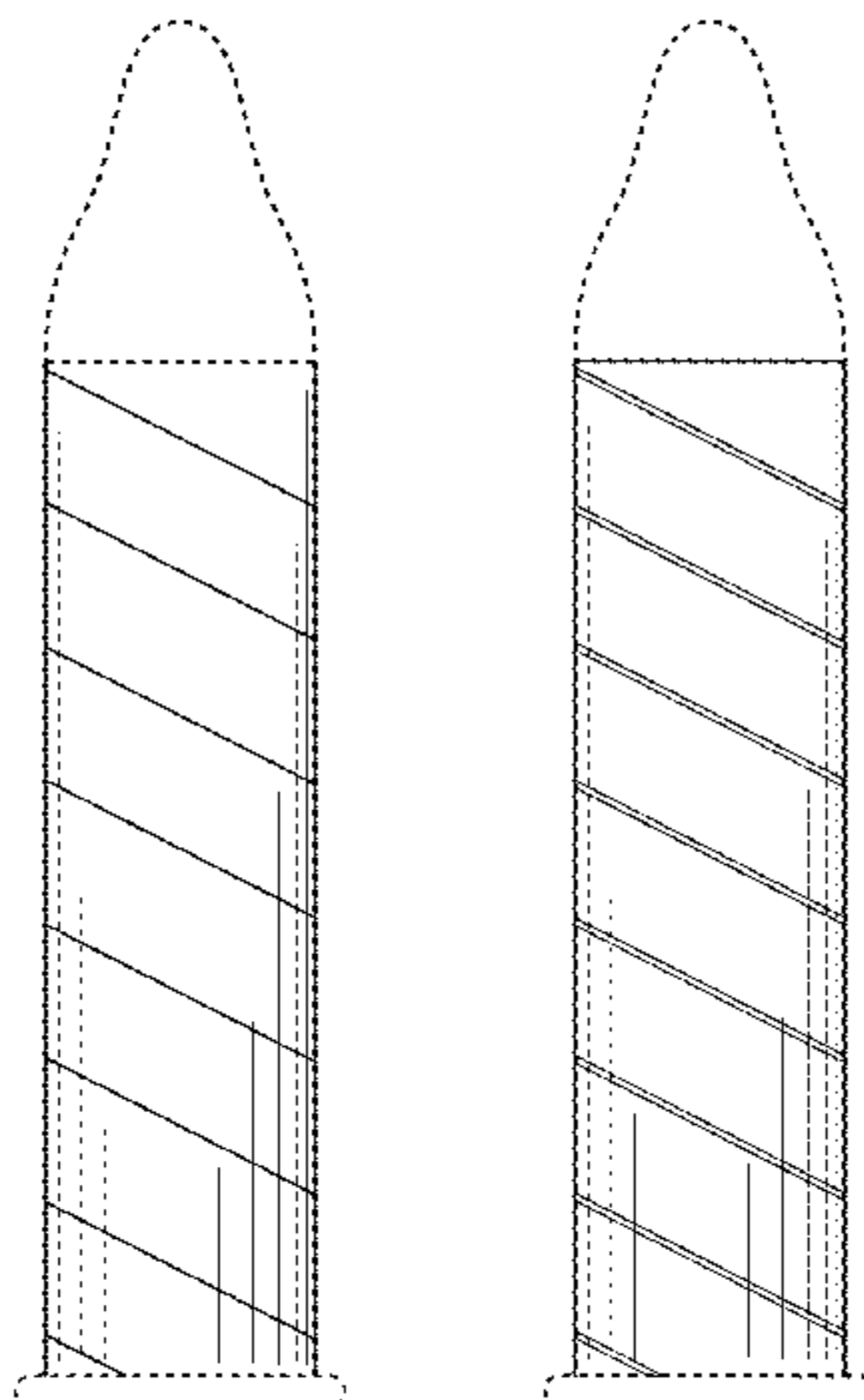

The broken line showing and all within of the base and tip of the condom forms no part of the claimed design.

**1 Claim, 32 Drawing Sheets
(15 of 32 Drawing Sheet(s) Filed in Color)**

(58) **Field of Classification Search**

CPC .. A61F 6/02; A61F 6/04; A61H 19/00; A61H 19/34; A61H 19/44

See application file for complete search history.

(56) **References Cited**

U.S. PATENT DOCUMENTS

2,041,909	A *	5/1936	Emmert	G09F 13/00
				40/427
D128,270	S *	7/1941	Torbeck et al.	D20/16
D195,350	S *	6/1963	Simkins	D20/16
D199,661	S *	12/1964	Rosen	30/141
D364,655	S *	11/1995	Weinstein	D21/440
5,623,945	A *	4/1997	Shecterle	A61F 6/04
				128/842
D426,311	S *	6/2000	Horowitz	D24/215
D427,477	S *	7/2000	Pope	D7/300.2
D544,039	S *	6/2007	Mora	D20/16
D593,195	S *	5/2009	Osterberg	D24/105
D602,153	S *	10/2009	Osterberg	D24/105
D731,073	S *	6/2015	Lv	D24/215
D731,074	S *	6/2015	Zhang	D24/215
D733,903	S *	7/2015	Tong	D24/215
2009/0074899	A1*	3/2009	Lipson	B29C 47/0023
				425/133.1

* cited by examiner

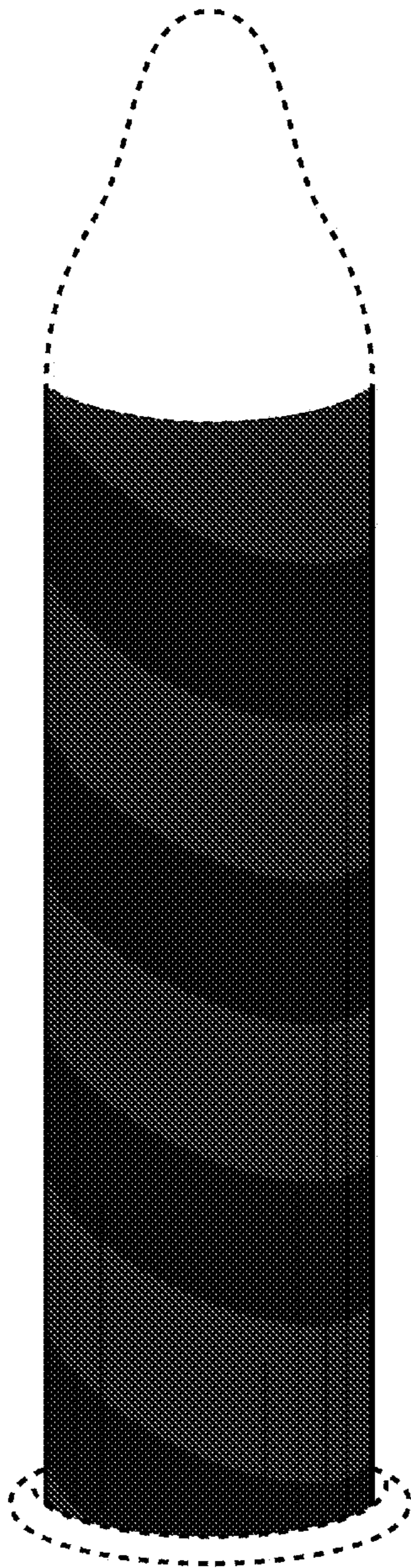

FIG. 1

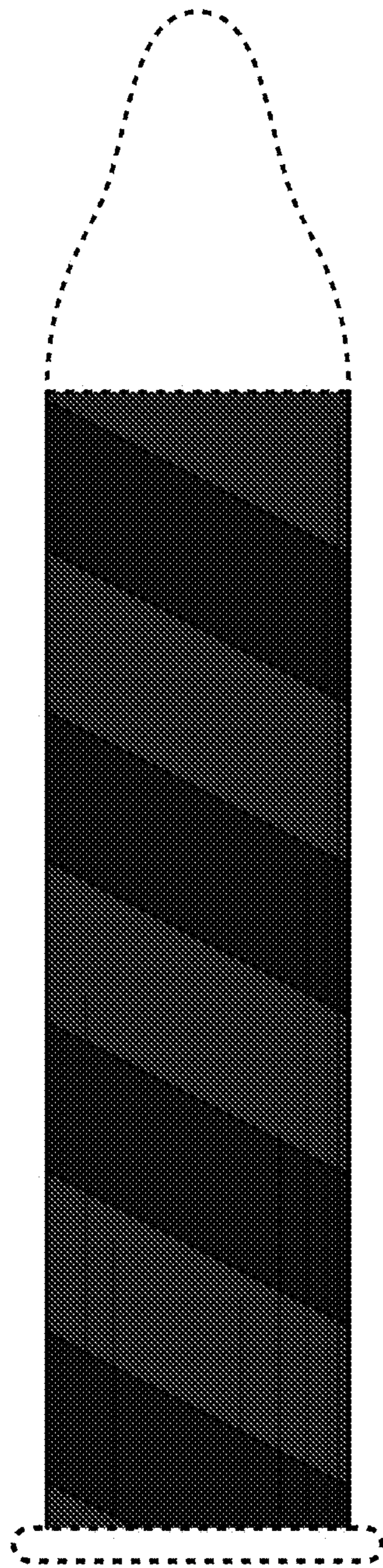

FIG. 2

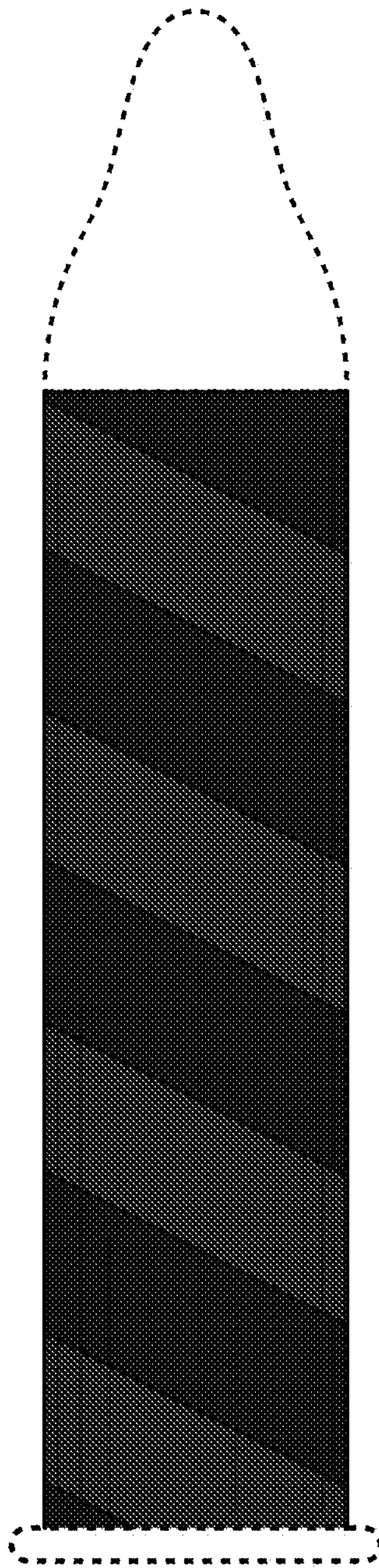

FIG. 3

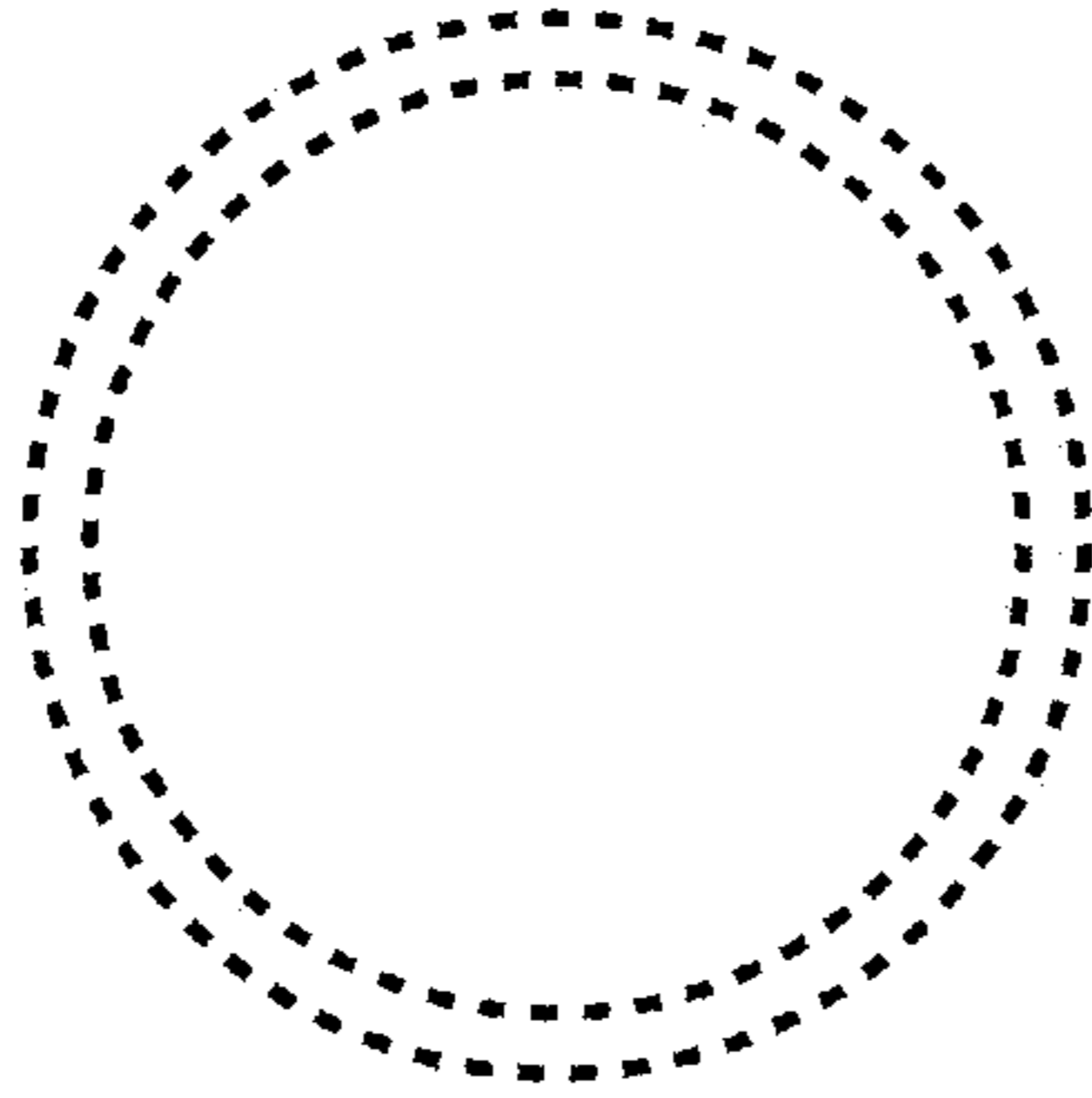

FIG. 4

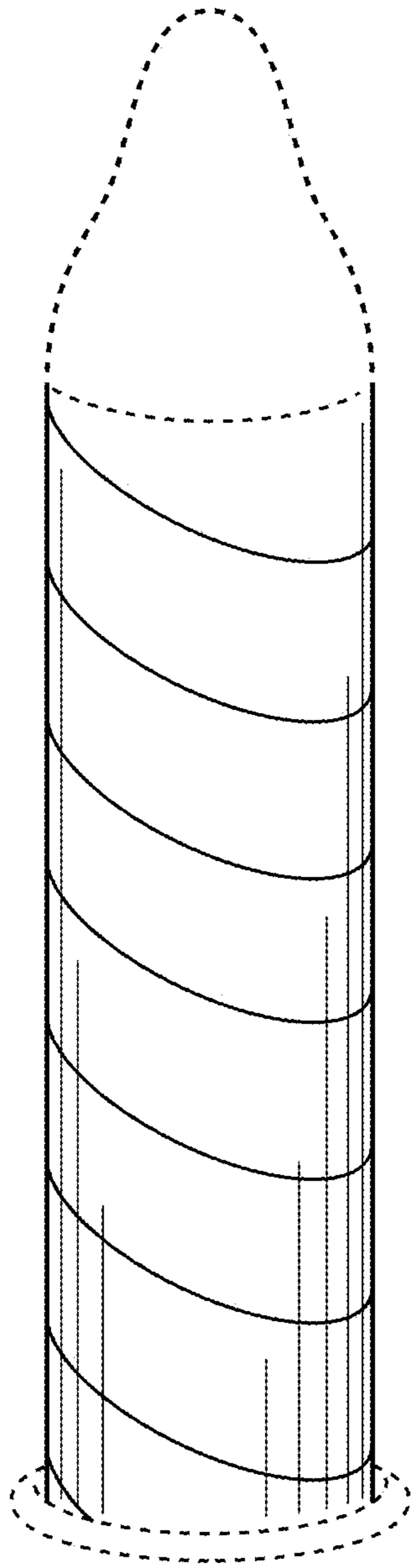

FIG. 5

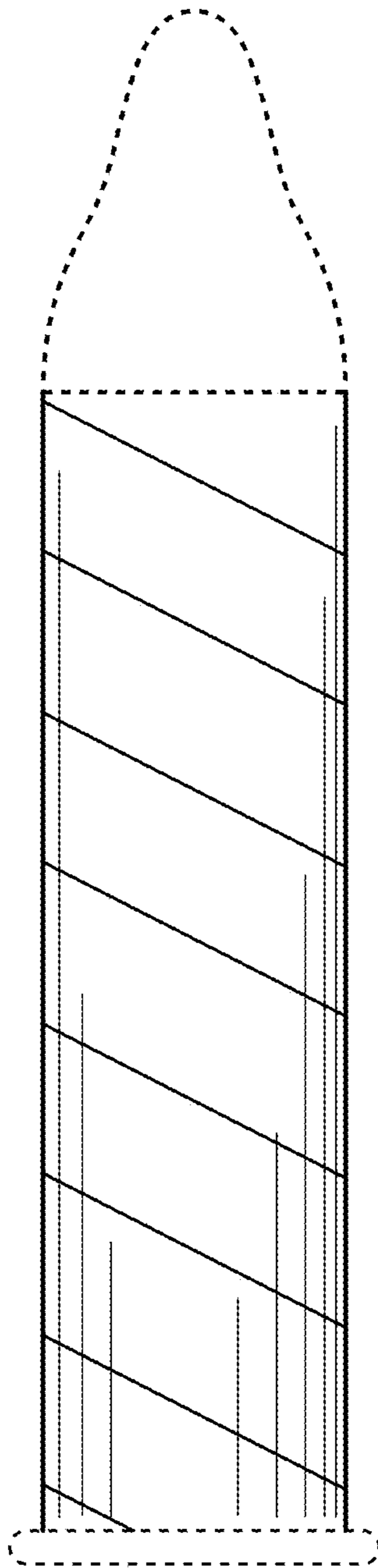

FIG. 6

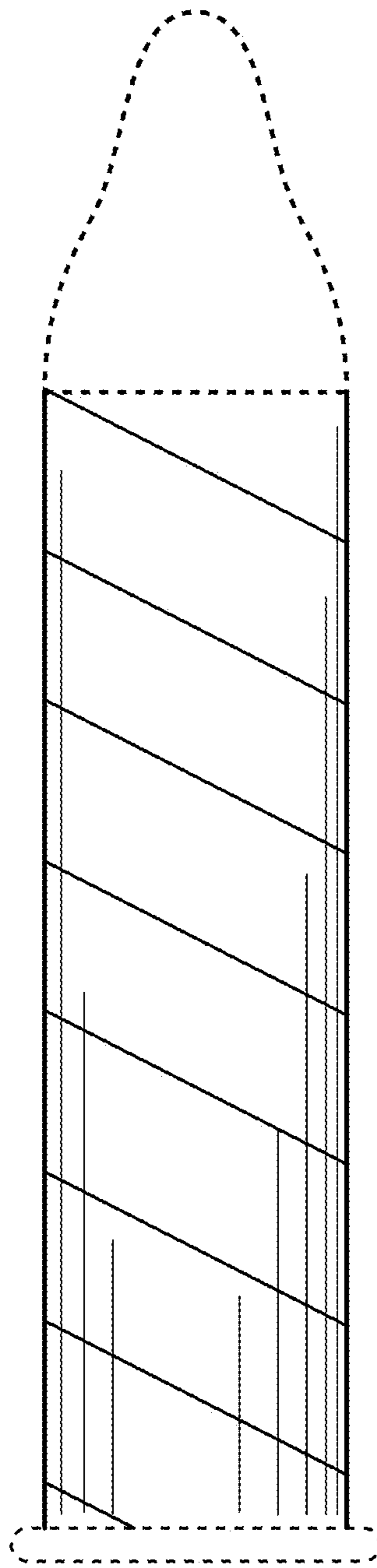

FIG. 7

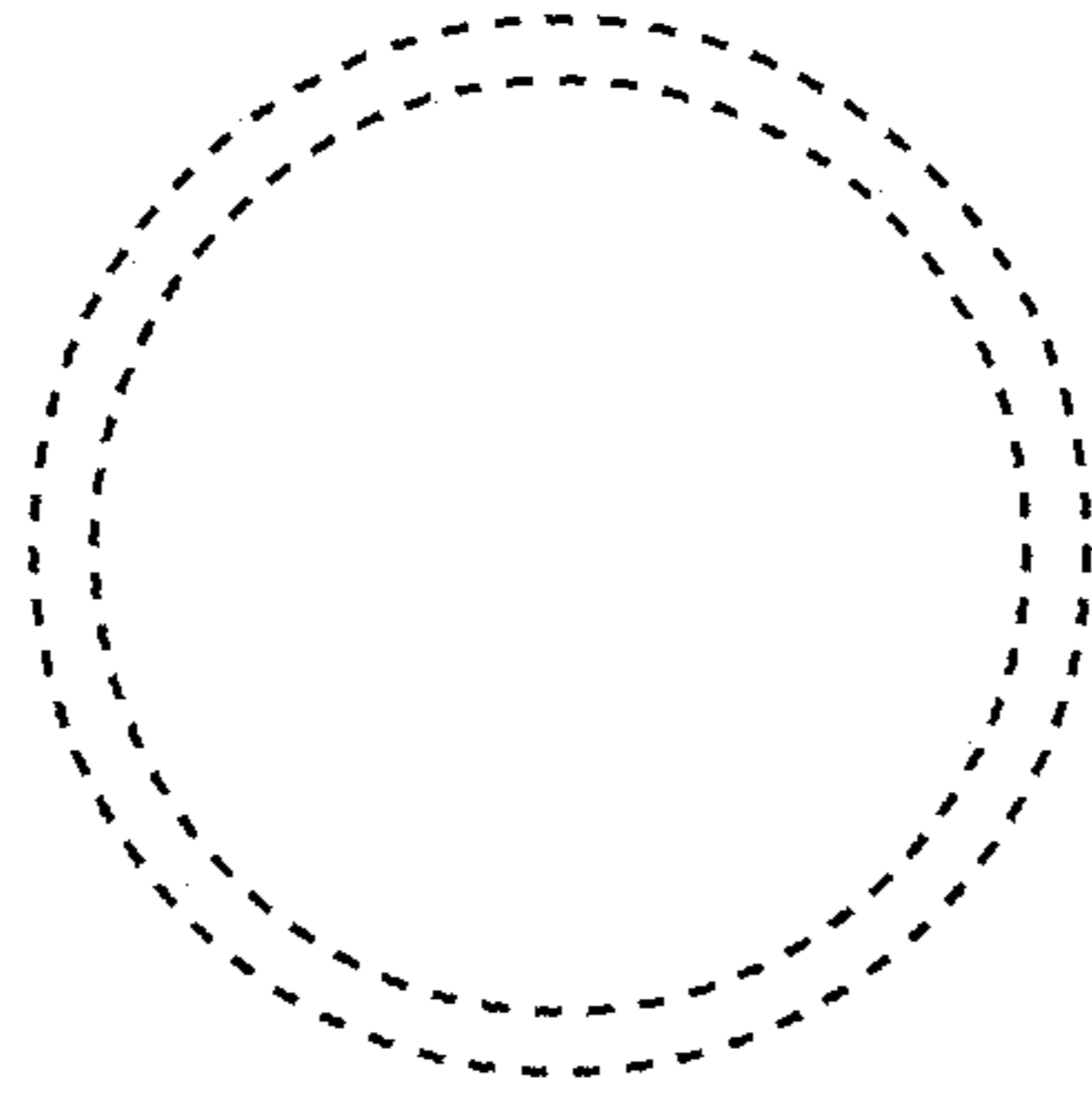

FIG. 8

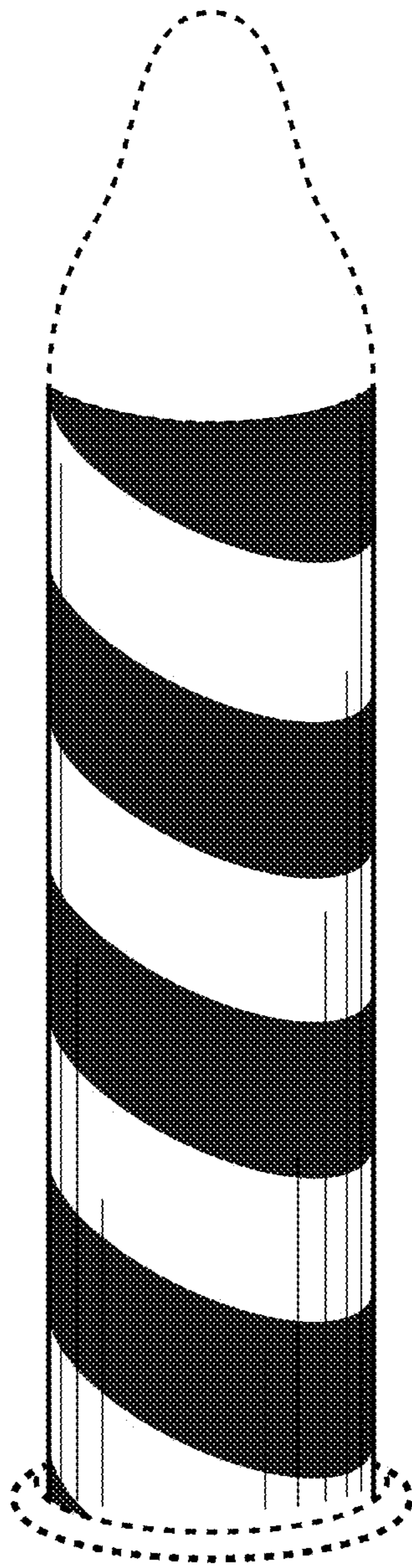

FIG. 9

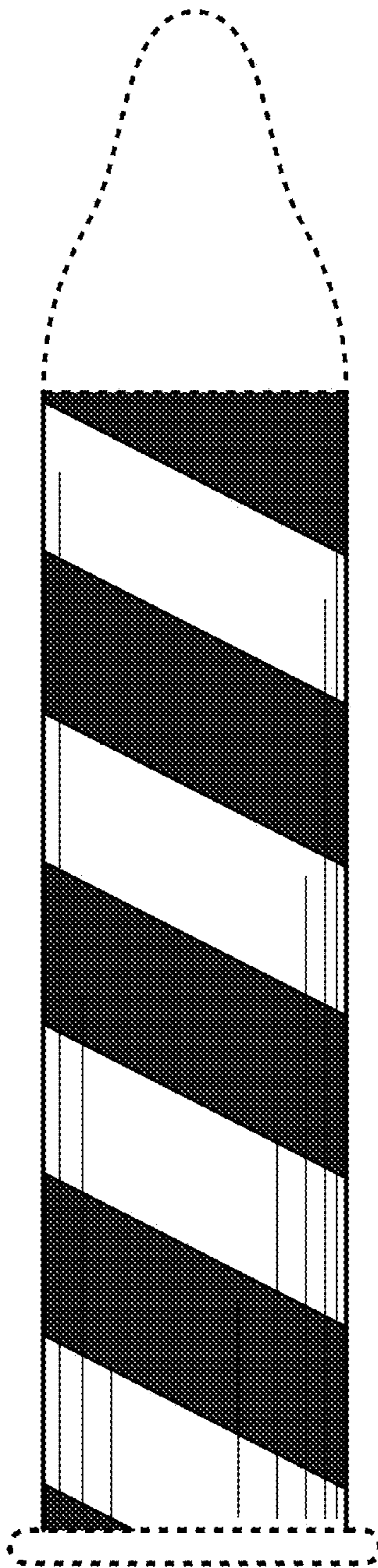

FIG. 10

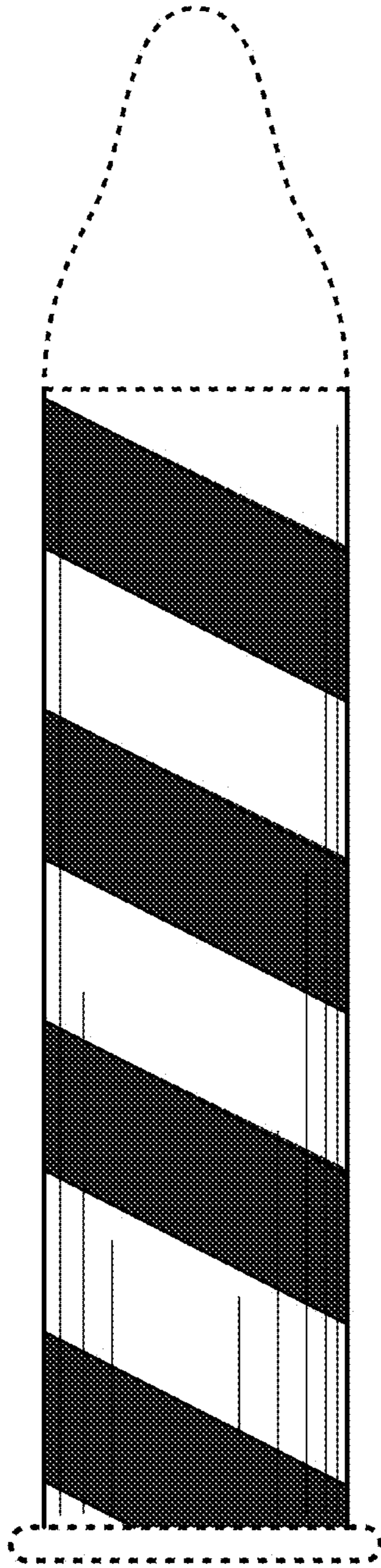

FIG. 11

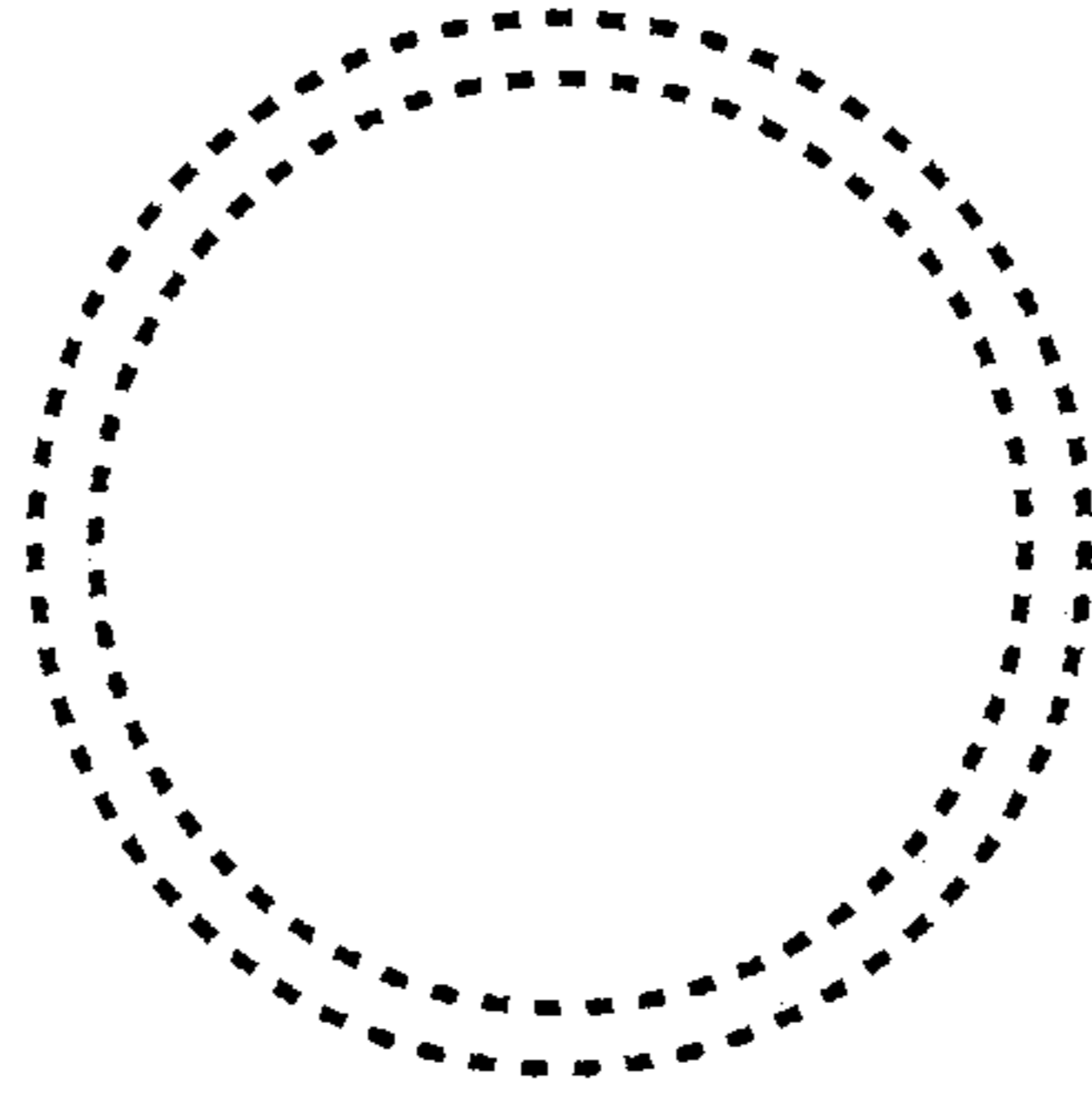

FIG. 12

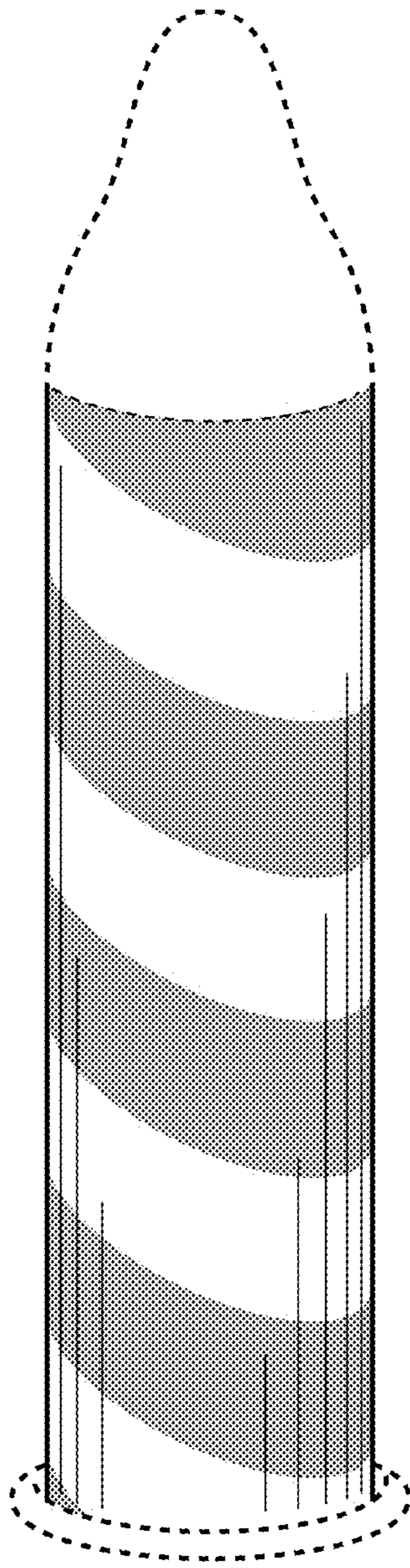

FIG. 13

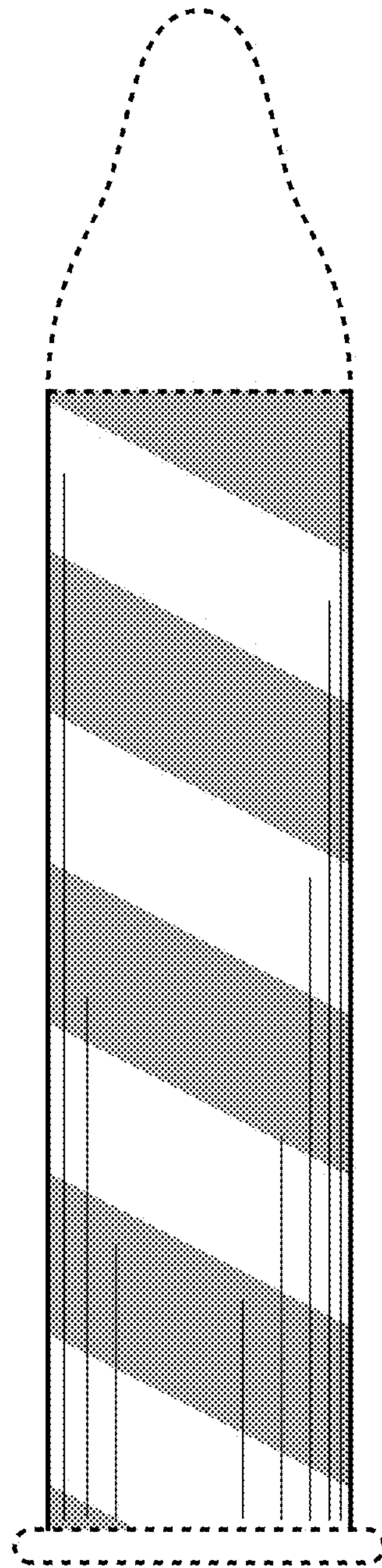

FIG. 14

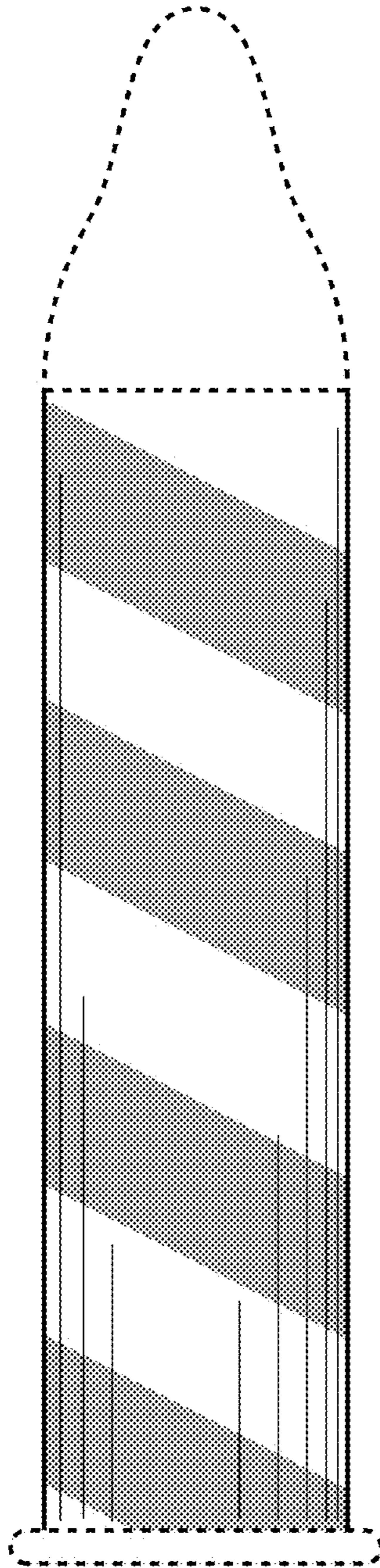

FIG. 15

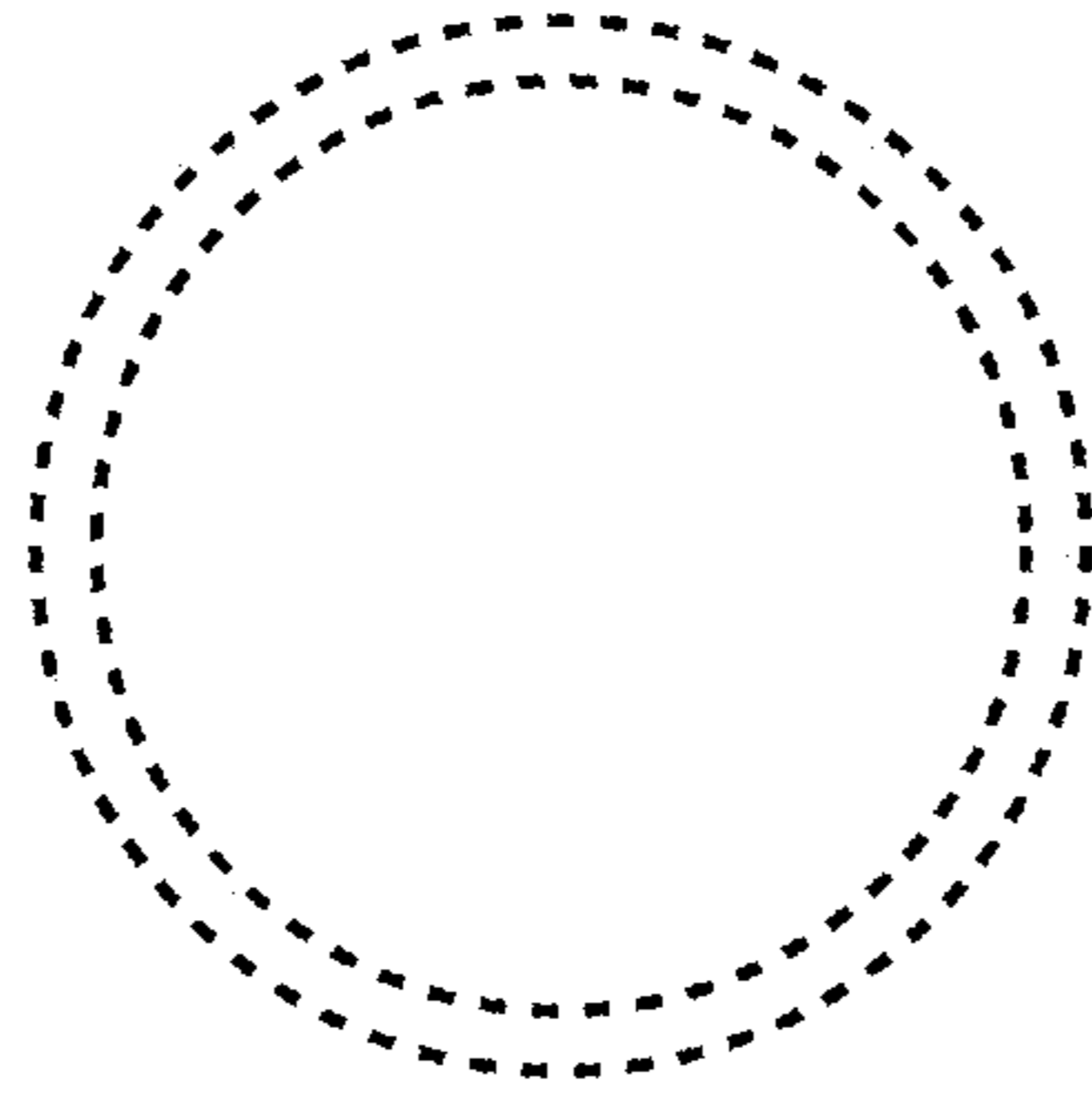

FIG. 16

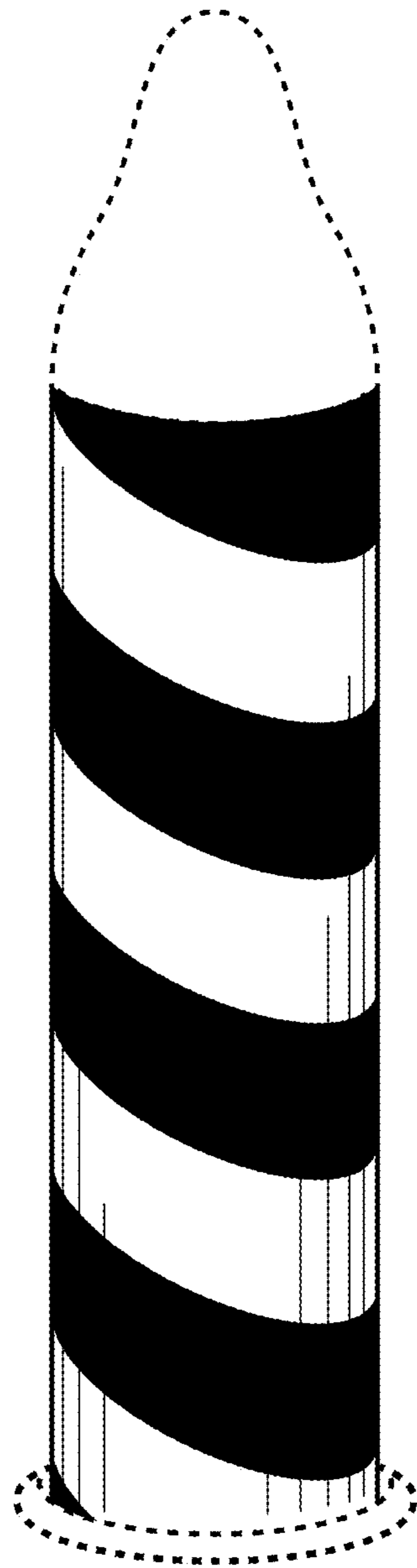

FIG. 17

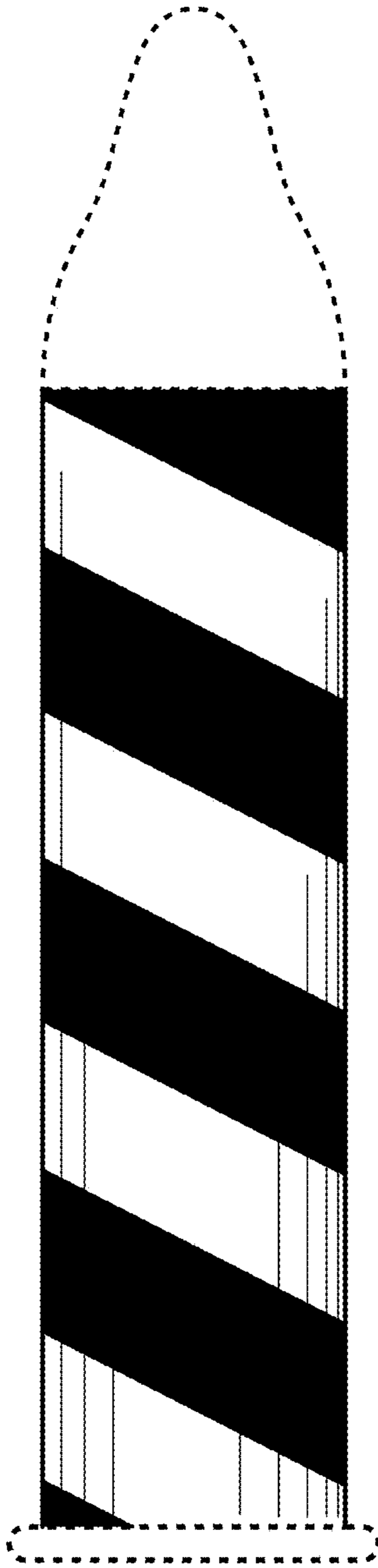

FIG. 18

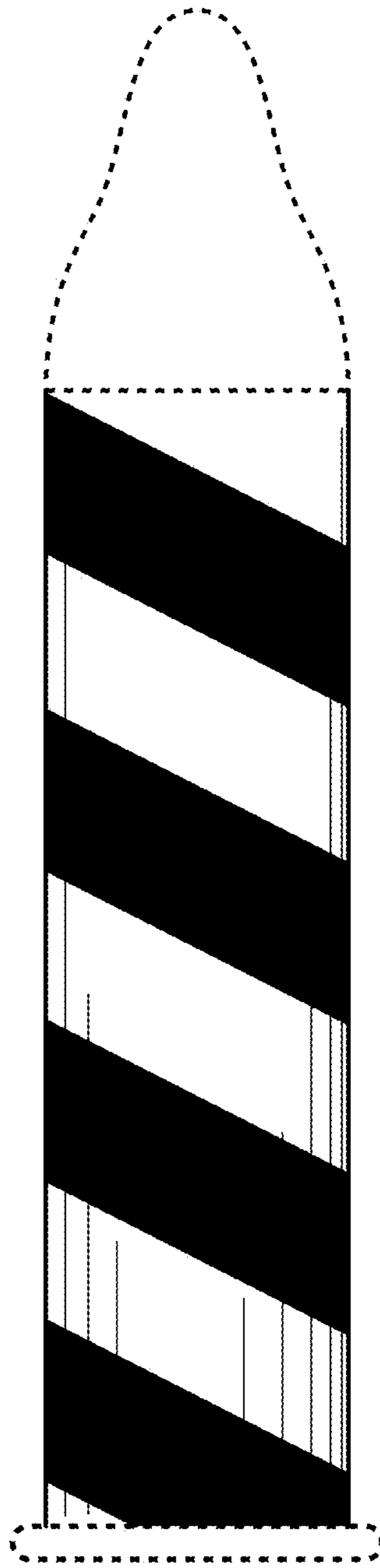

FIG. 19

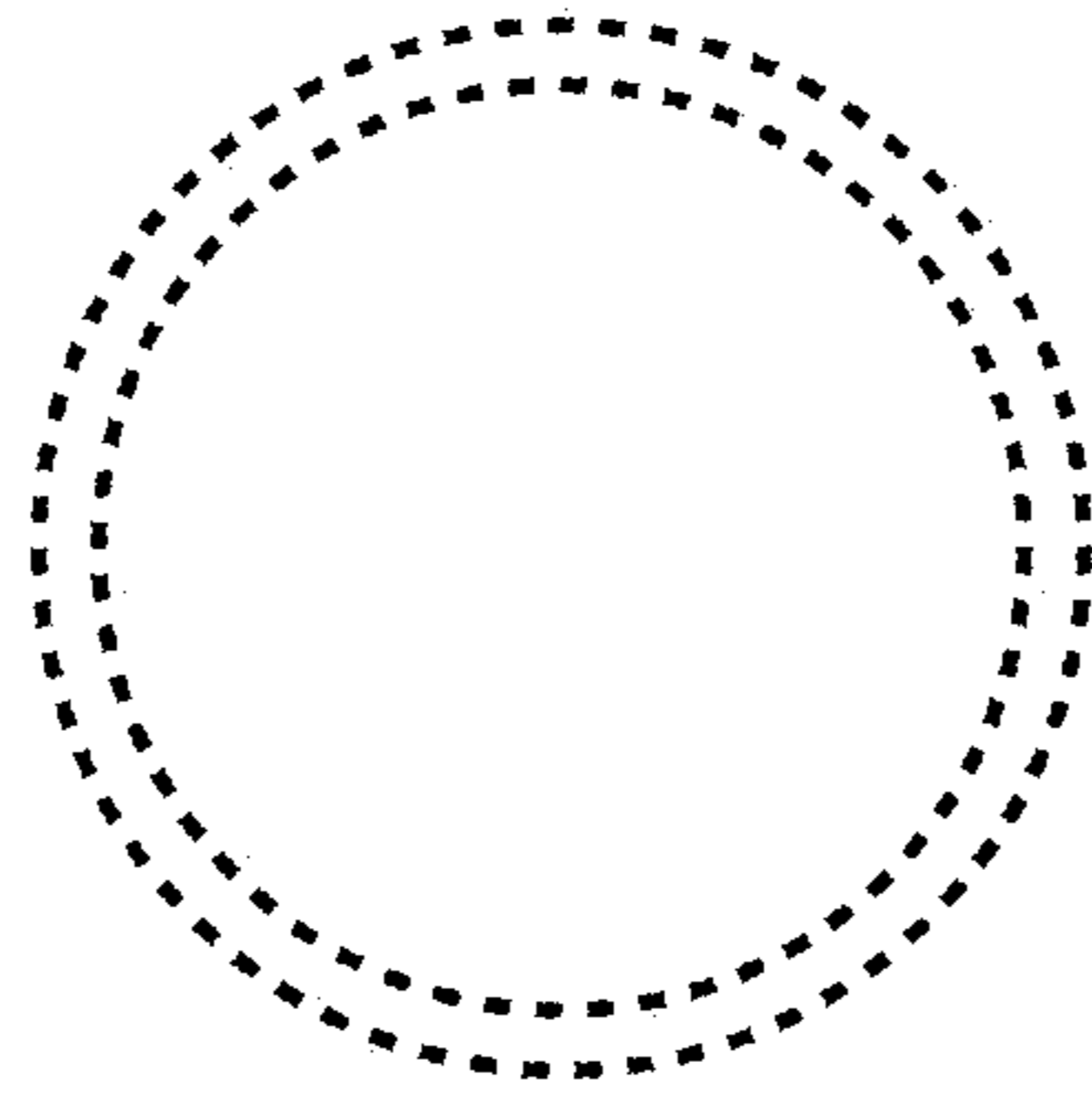

FIG. 20

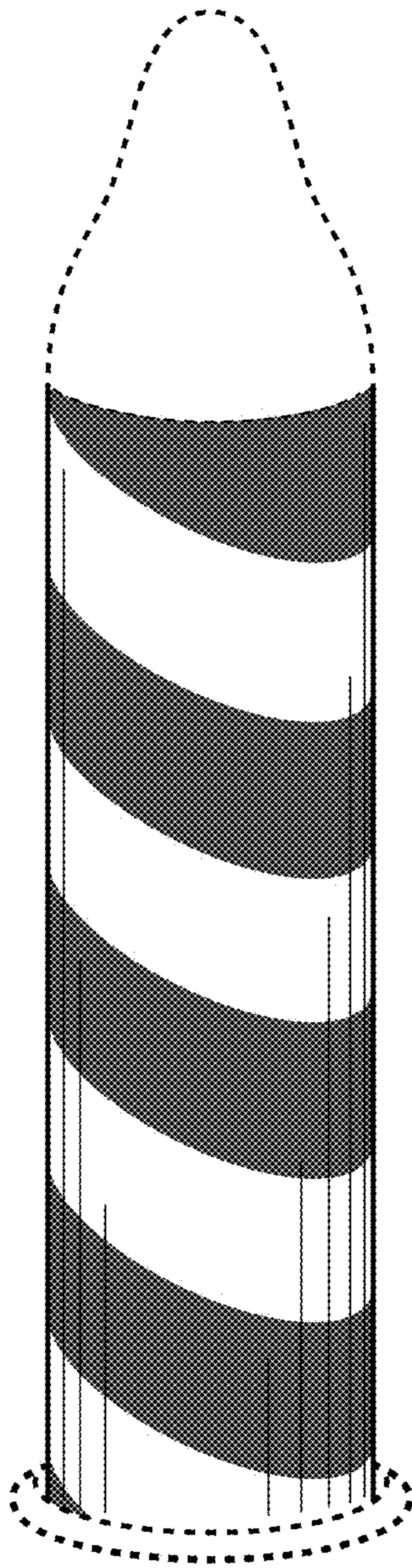

FIG. 21

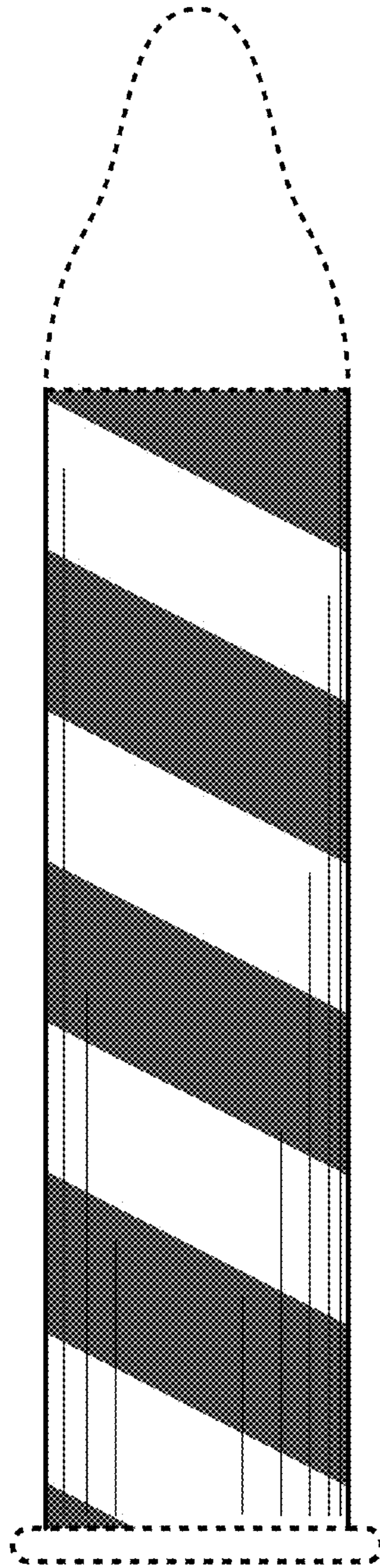

FIG. 22

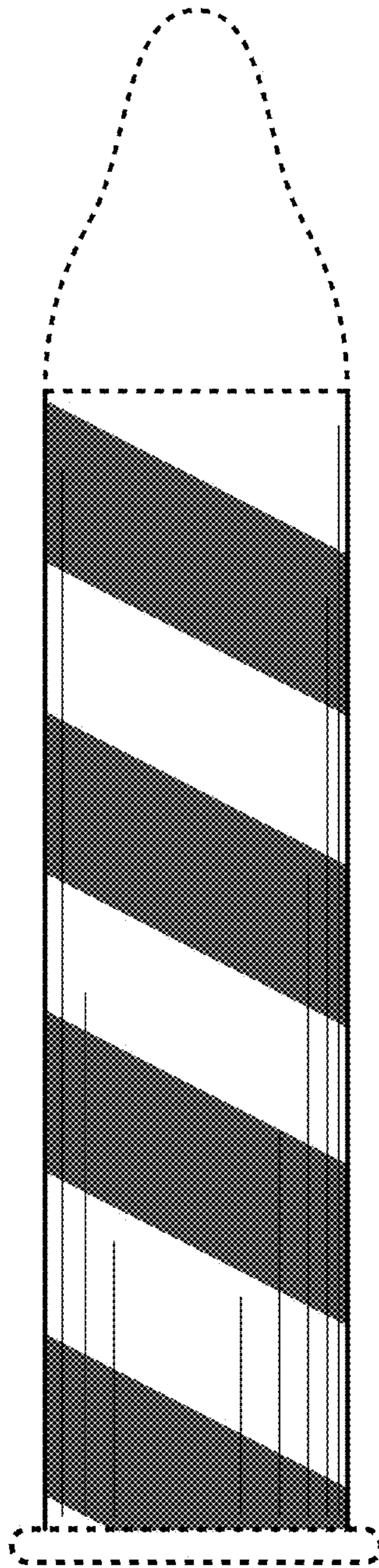

FIG. 23

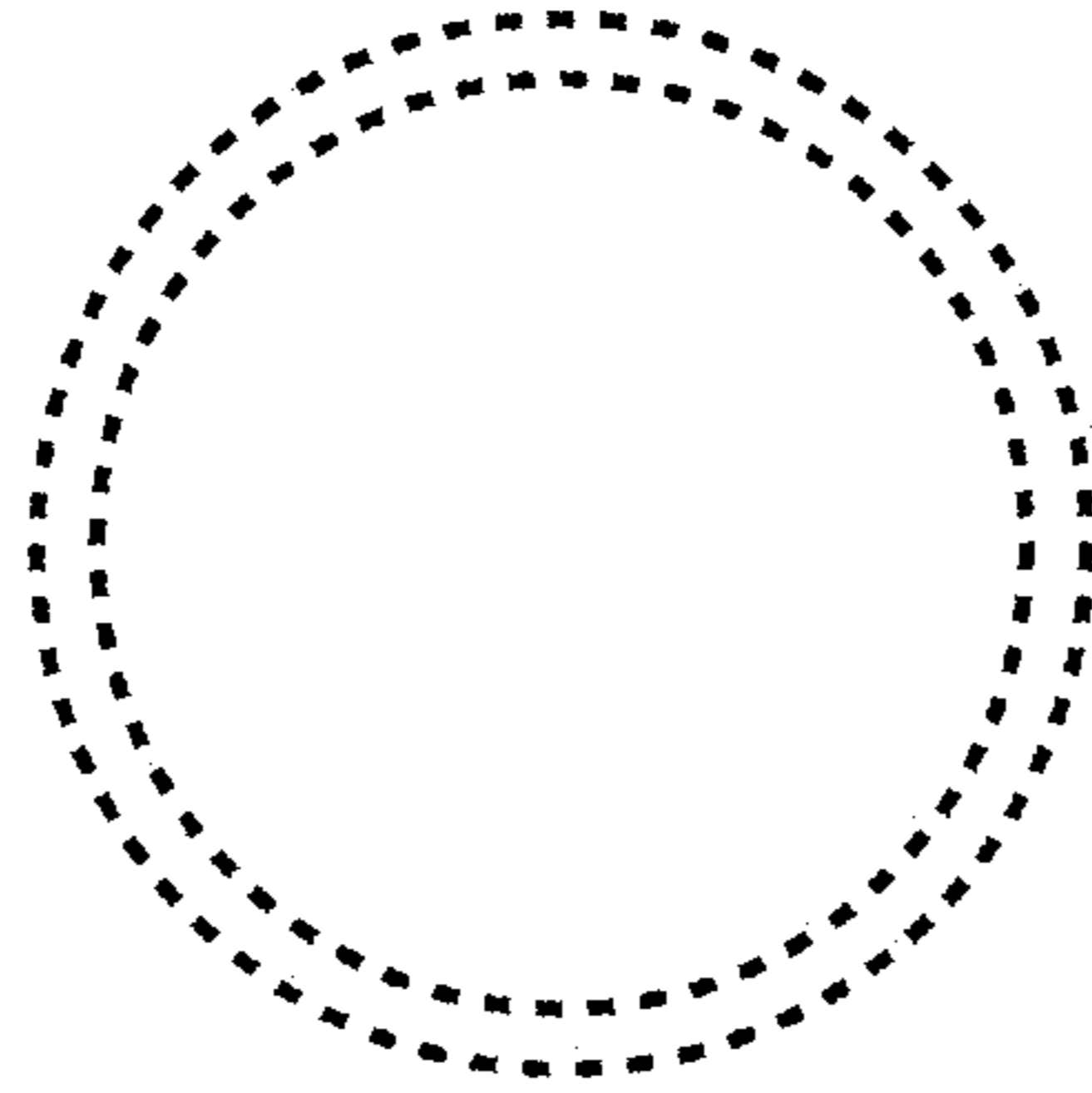

FIG. 24

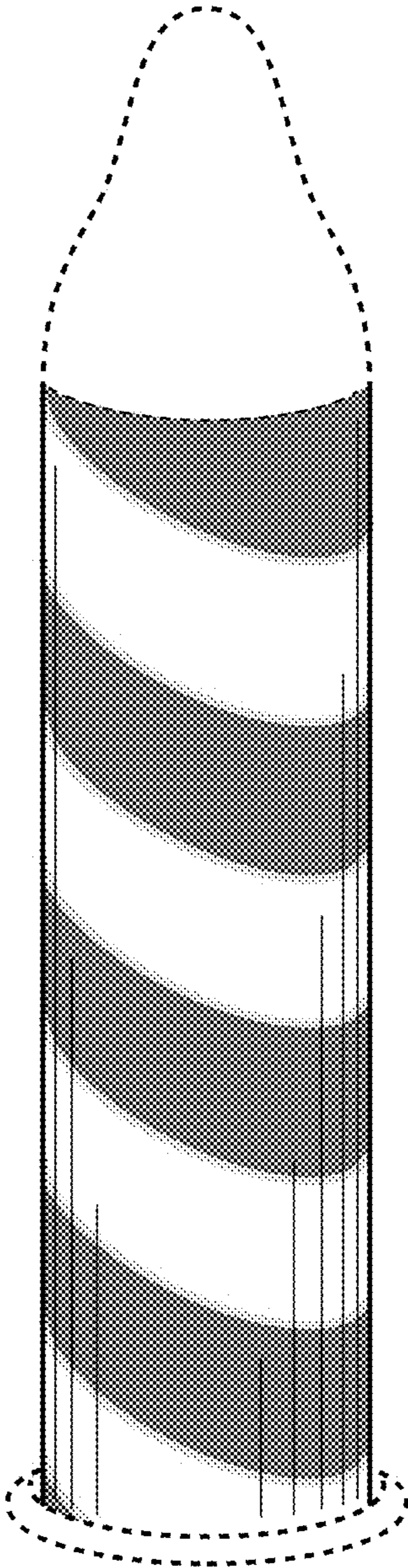

FIG. 25

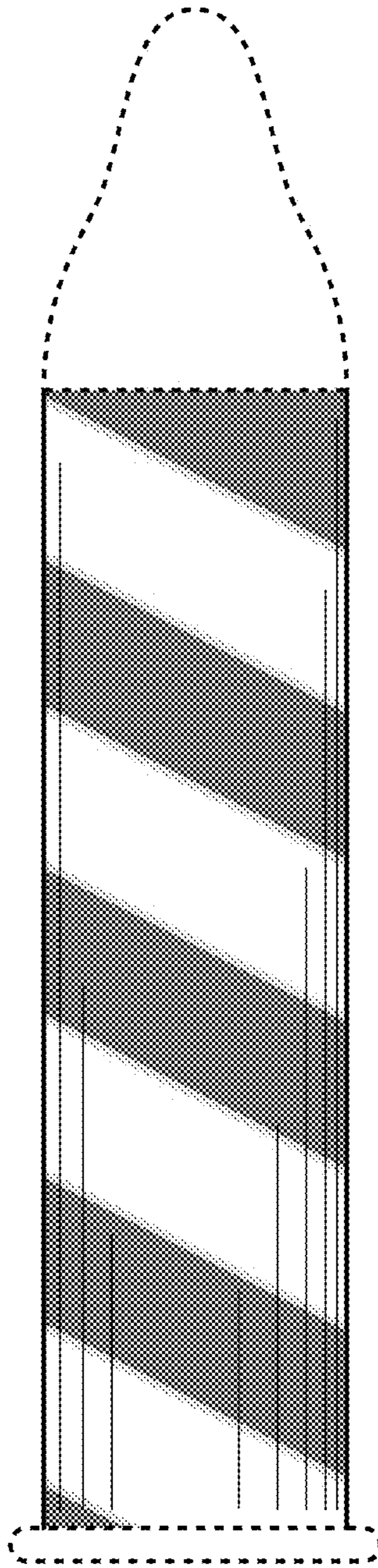

FIG. 26

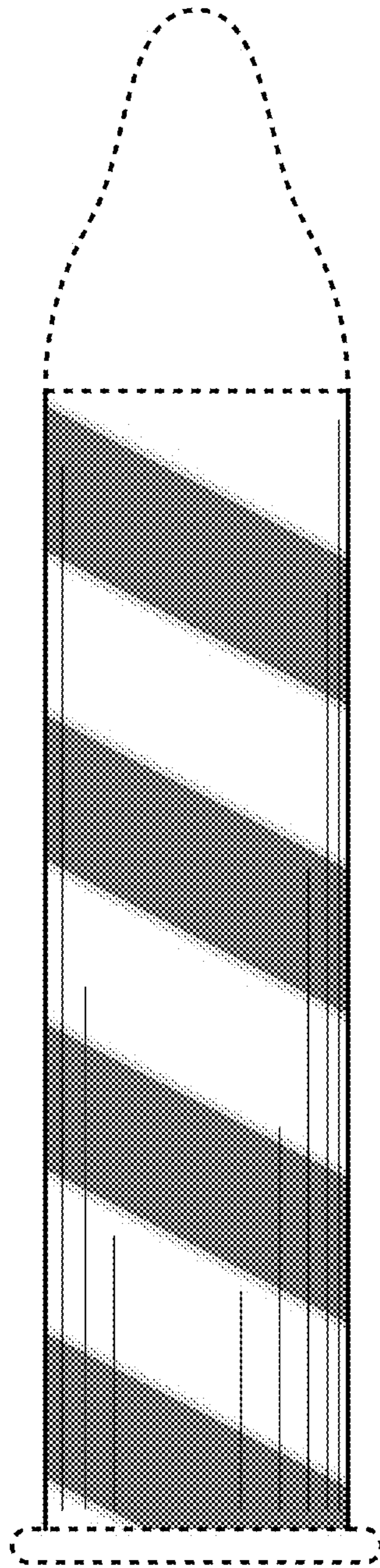

FIG. 27

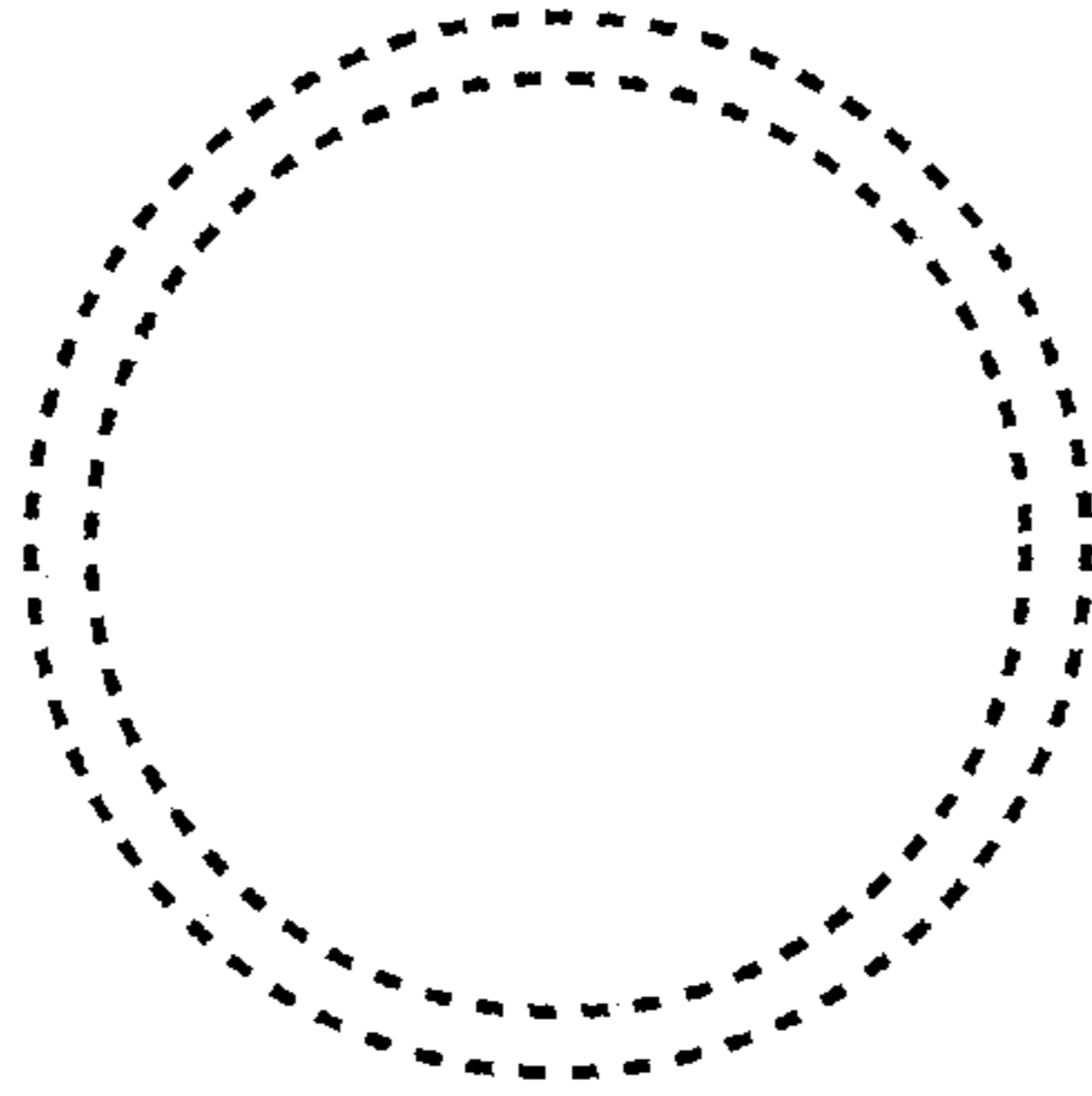

FIG. 28

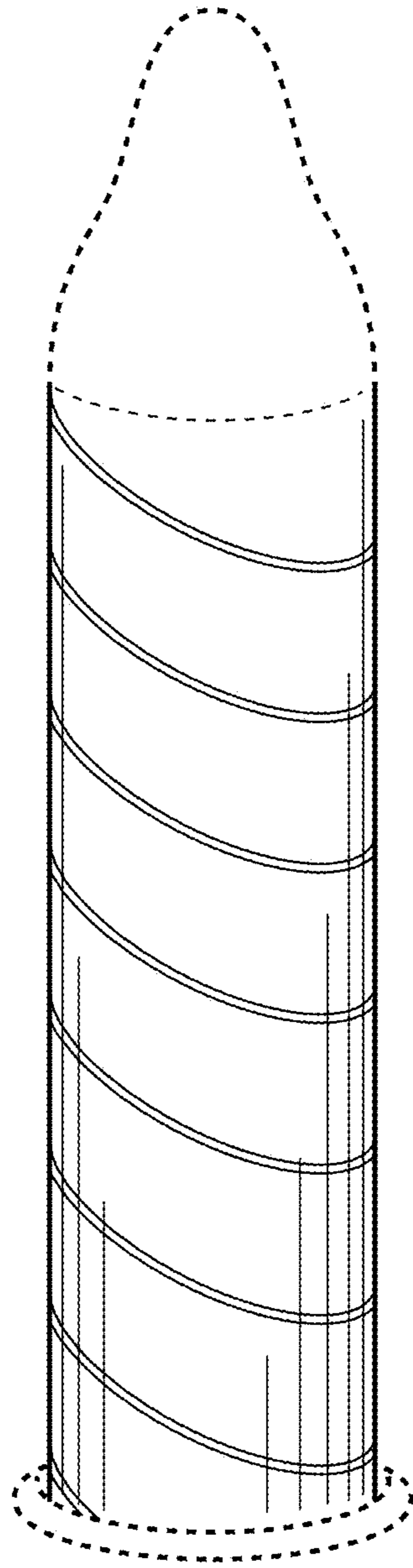

FIG. 29

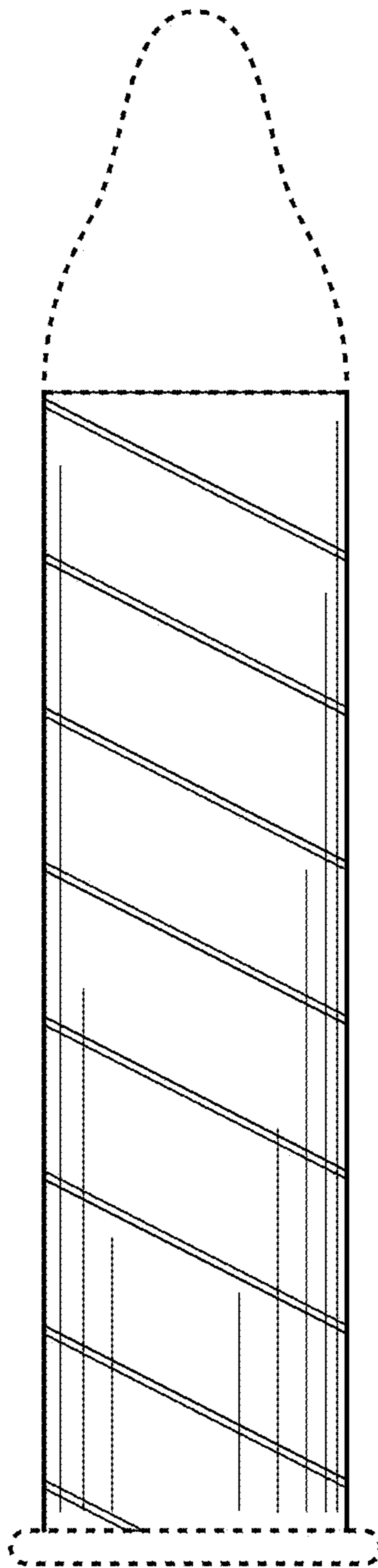

FIG. 30

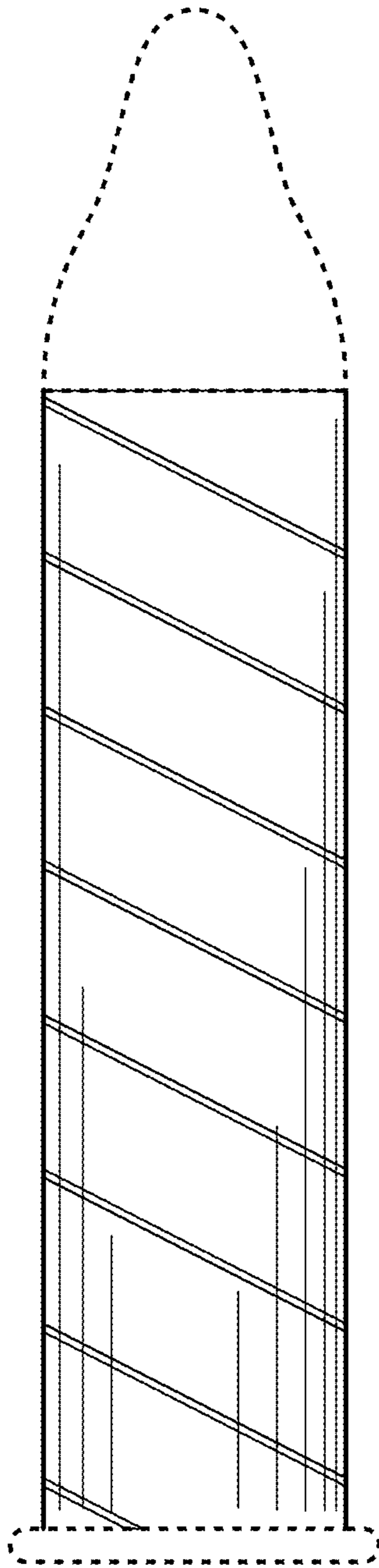

FIG. 31

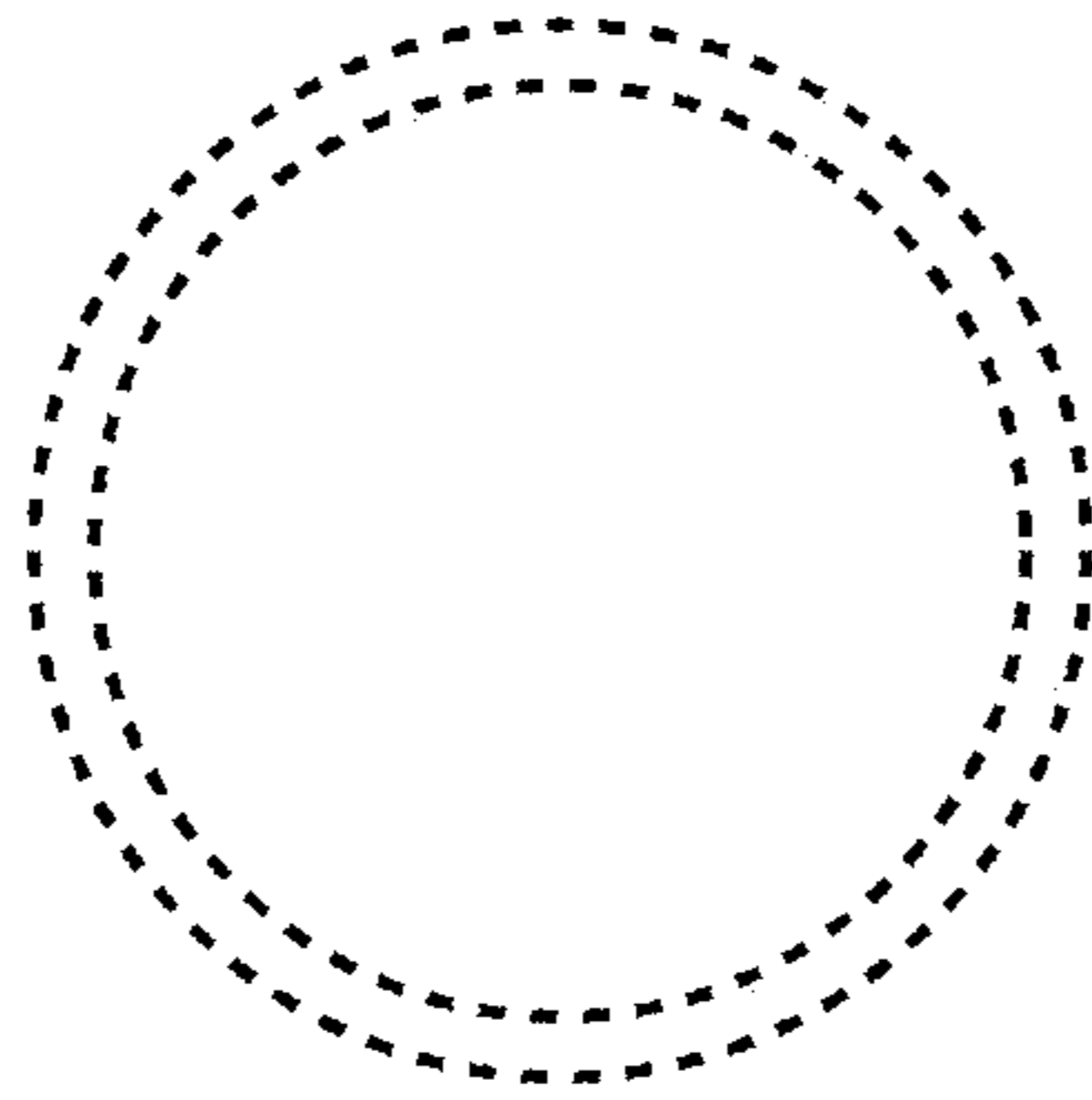

FIG. 32