



US00D814557S

(12) **United States Design Patent**
Canivell Grifols

(10) **Patent No.:** **US D814,557 S**

(45) **Date of Patent:** **** Apr. 3, 2018**

(54) **HEADSTOCK**

(71) Applicant: **LLEVINAC, S.L.**, Barcelona (ES)

(72) Inventor: **Jordi Canivell Grifols**, Barcelona (ES)

(73) Assignee: **LLEVINAC, S.L.**, Barcelona (ES)

(**) Term: **15 Years**

(21) Appl. No.: **29/571,427**

(22) Filed: **Jul. 18, 2016**

(30) **Foreign Application Priority Data**

Jan. 19, 2016 (EM) 002951004-0001

(51) **LOC (11) Cl.** **17-03**

(52) **U.S. Cl.**
USPC **D17/20**

(58) **Field of Classification Search**
USPC D17/14-21, 99; D21/324
CPC .. G10D 3/00; G10D 3/02; G10D 3/06; G10D
3/08; G10D 3/12; G10D 3/14; G10D
1/00; G10D 1/06; G10D 1/08; G10D
1/085; G10H 3/00; G10H 3/18; G10H
3/181

See application file for complete search history.

(56) **References Cited**

U.S. PATENT DOCUMENTS

D209,706 S *	12/1967	Podall	D17/20
D277,765 S *	2/1985	Sugai	D17/20
D404,061 S *	1/1999	Roth	D17/20
D416,935 S *	11/1999	DeCola	D17/20
D516,609 S *	3/2006	Rose	D17/20
D589,512 S *	3/2009	Gray	D14/400
D681,104 S *	4/2013	Yi	D17/20

2002/0162443 A1*	11/2002	Pittman	G10D 1/00 84/291
2003/0070527 A1*	4/2003	Gregory	G10D 3/14 84/290
2005/0204891 A1*	9/2005	Cherubini	G10D 3/14 84/290

OTHER PUBLICATIONS

Youtube, 20:14 Guitar—Adam Guitars, posted on Apr. 11, 2016, [online], [site visited on Sep. 14, 2017]. Available from Internet, URL: <https://www.youtube.com/watch?v=7lqpcBbbcW4> (Year: 2016).*

(Continued)

Primary Examiner — Sheryl Lane

Assistant Examiner — Samantha N Wood

(74) *Attorney, Agent, or Firm* — Knobbe Martens Olson & Bear LLP

(57) **CLAIM**

The ornamental design for a headstock, as shown and described.

DESCRIPTION

FIG. 1 is a first perspective view of a headstock showing my new design.

FIG. 2 is a top plan view thereof.

FIG. 3 is a left side elevational view thereof.

FIG. 4 is a right side elevational view thereof.

FIG. 5 is a front elevational view thereof.

FIG. 6 is a rear elevational view thereof.

FIG. 7 is an enlarged view of the headstock as shown in FIG. 1; and,

FIG. 8 is an enlarged view of the headstock as shown in FIG. 5.

The broken lines in FIGS. 1-8 showing portions of a guitar body and neck are included for the purpose of illustrating environmental structure and form no part of the claimed design.

1 Claim, 8 Drawing Sheets

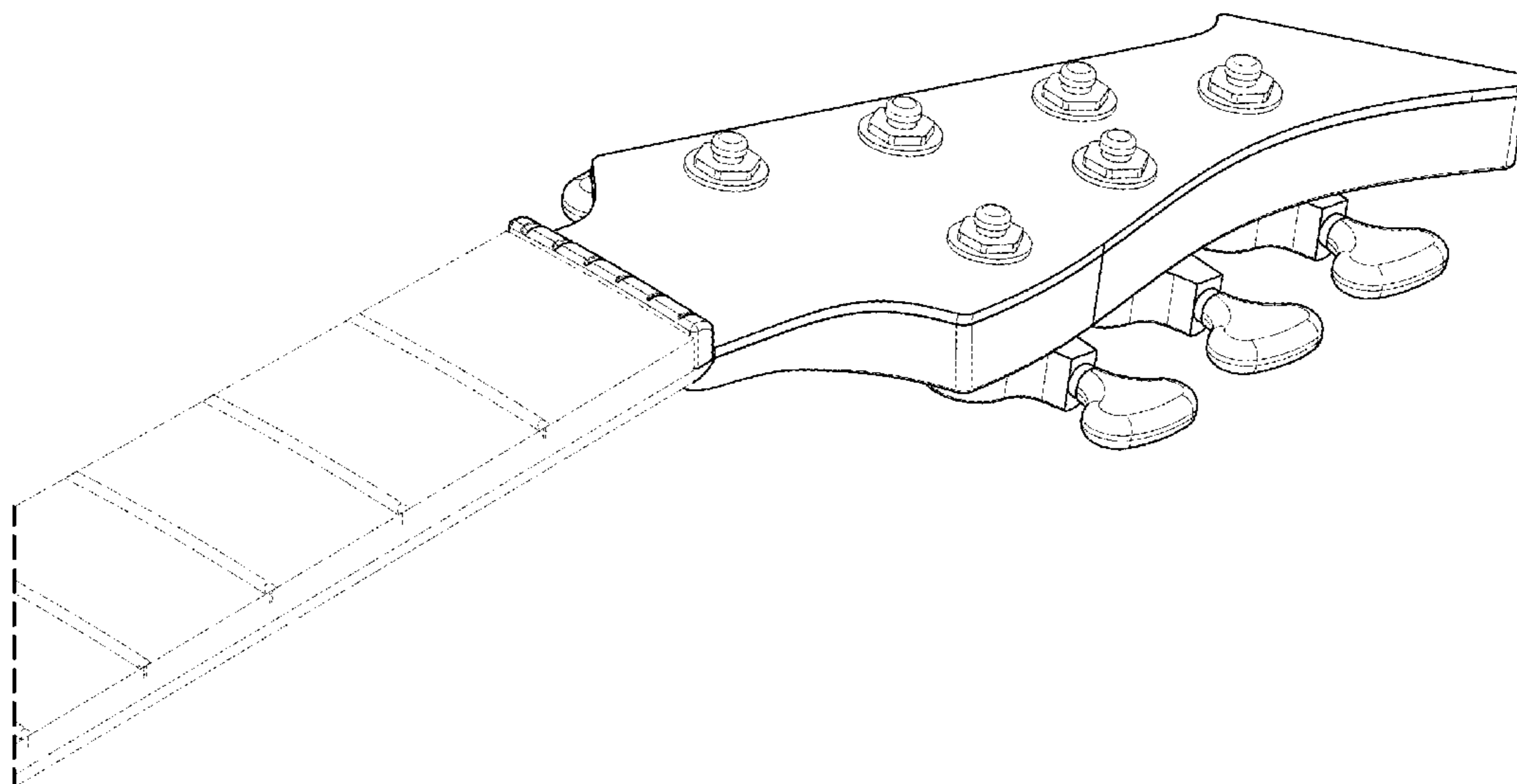

(56)

References Cited

OTHER PUBLICATIONS

Wikimedia, ESPLTD Alexi Laiho Headstock, posted on Jul. 2, 2009, [online], [site visited on Sep. 14, 2017]. Available from Internet, URL: <https://commons.wikimedia.org/wiki/File:ESPLTDALEXIHEADSTOCK.JPG> (Year: 2009).*

Youtube, 20:14 Guitar—First Demo, posted on Jan. 14, 2016, [online], [site visited on Sep. 14, 2017]. Available from Internet, URL: <https://www.youtube.com/watch?v=g4JrxAakXtl>(Year: 2016).*

* cited by examiner

FIG. 1

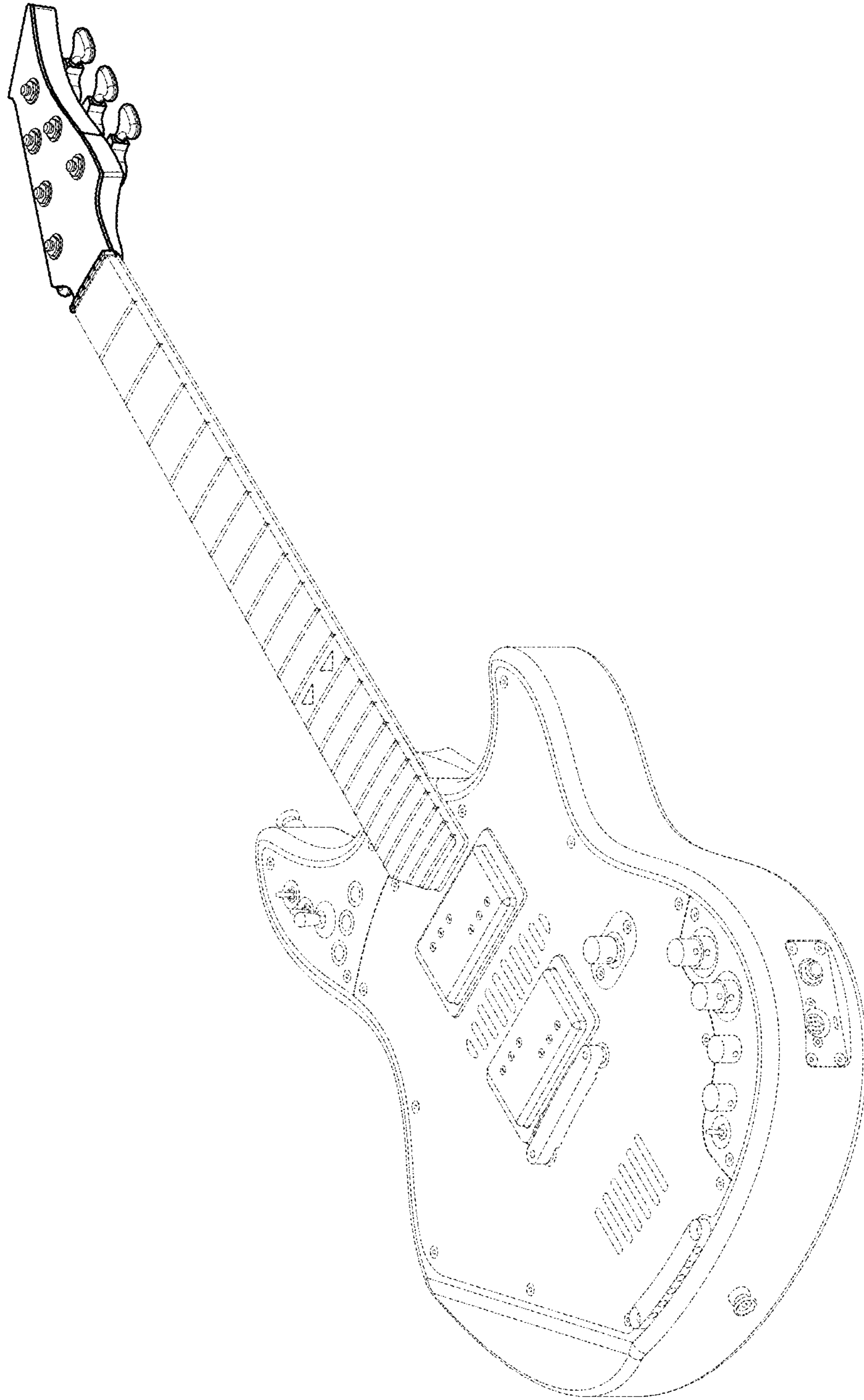

FIG. 2

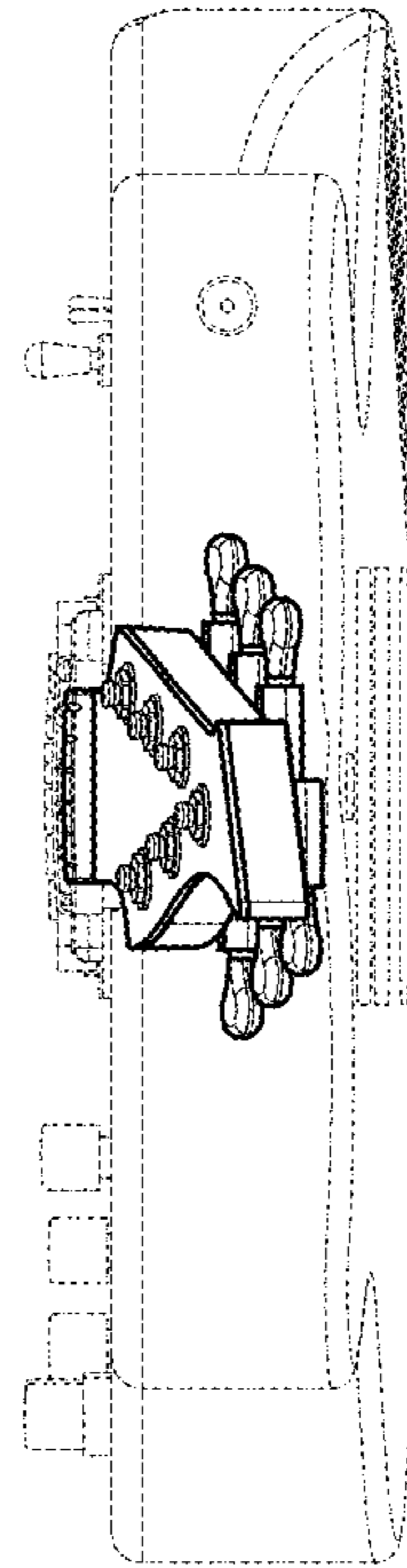

FIG. 3

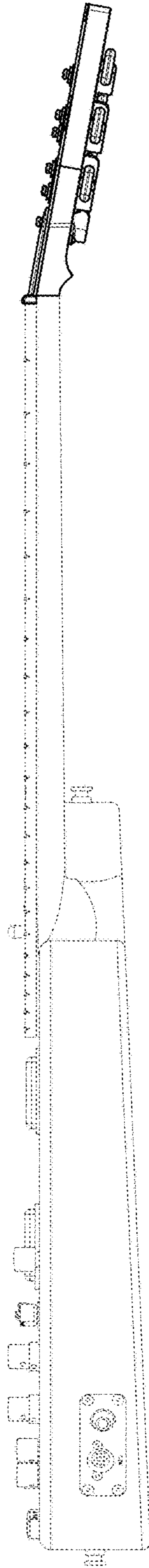

FIG. 4

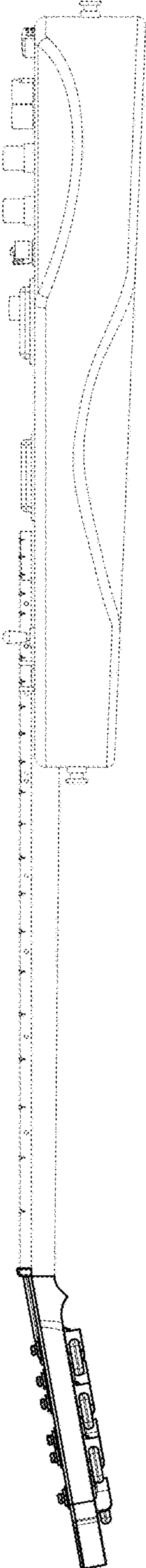

FIG. 5

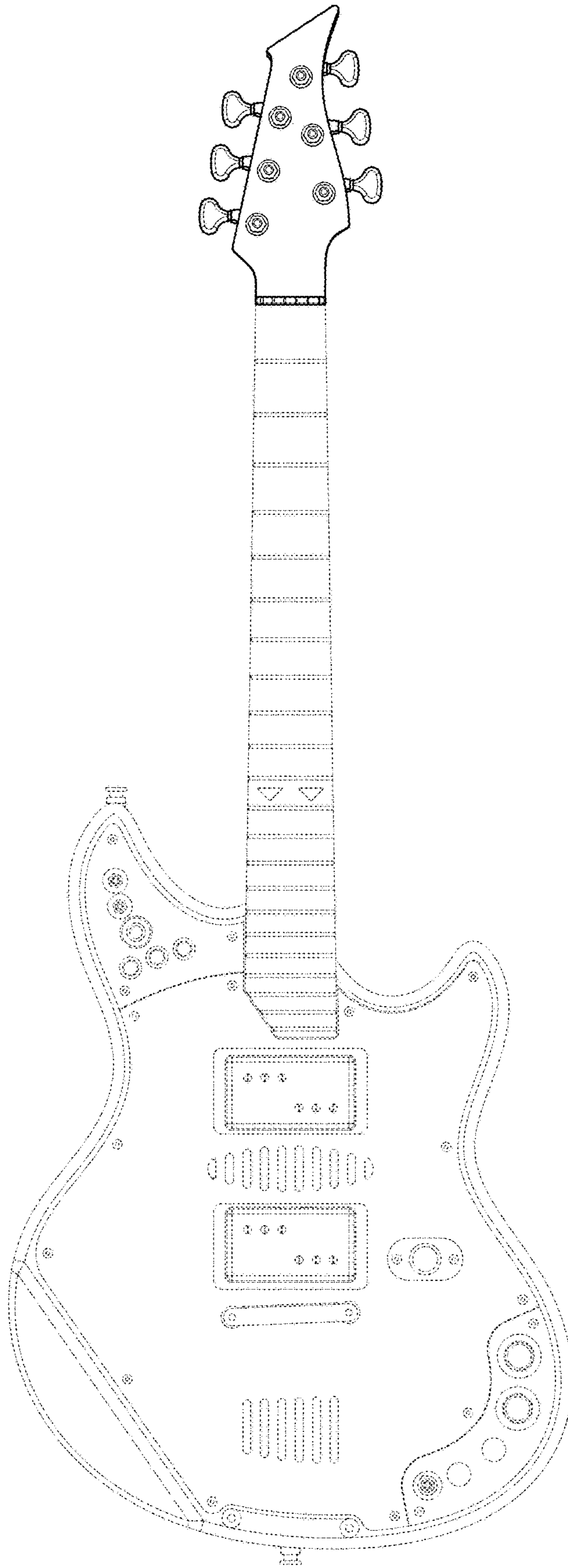

FIG. 6

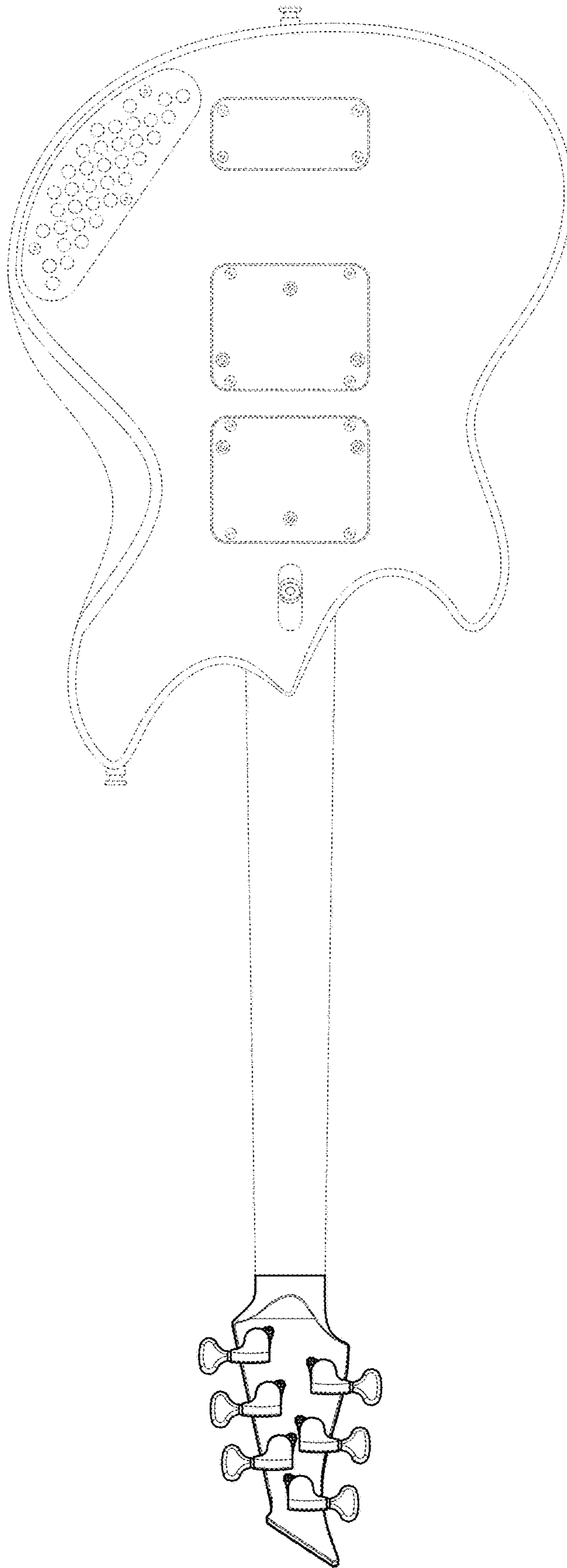

FIG. 7

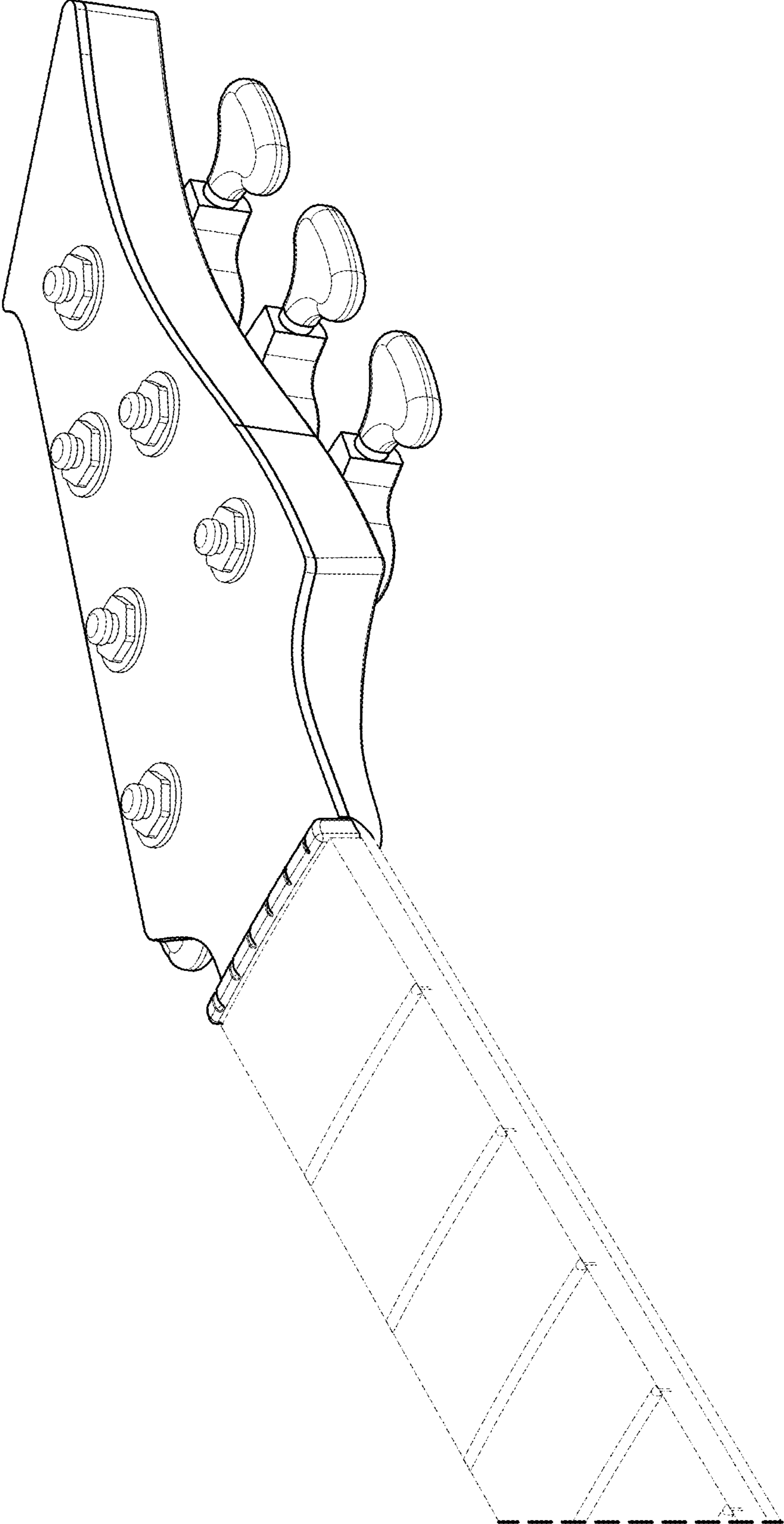

FIG. 8

