



US00D814538S

(12) **United States Design Patent** (10) **Patent No.:** **US D814,538 S**
Page (45) **Date of Patent:** **** Apr. 3, 2018**

(54) **WELDING APPARATUS**

(71) Applicant: **Justin Vaughn Page**, Lloydminster (CA)

(72) Inventor: **Justin Vaughn Page**, Lloydminster (CA)

(**) Term: **15 Years**

(21) Appl. No.: **29/576,675**

(22) Filed: **Sep. 6, 2016**

Related U.S. Application Data

(63) Continuation of application No. 12/619,252, filed on Nov. 16, 2009, now Pat. No. 9,434,030.

(51) **LOC (11) Cl.** **15-09**

(52) **U.S. Cl.**
USPC **D15/144**

(58) **Field of Classification Search**
USPC D8/29.1, 30, 123, 133; D15/144, 14.1, D15/144.2

(Continued)

(56) **References Cited**

U.S. PATENT DOCUMENTS

1,922,913 A 8/1933 Free et al.
2,800,867 A 7/1957 Ross

(Continued)

FOREIGN PATENT DOCUMENTS

CA 10019600 10/1977
JP 6106346 A 4/1994

(Continued)

OTHER PUBLICATIONS

Justin V. Page, Australian Application No. 2009319652, Notice of Acceptance, dated Jan. 3, 2014.

(Continued)

Primary Examiner — Patricia A Palasik

(74) *Attorney, Agent, or Firm* — Michael G. Johnston; Moore & Van Allen PLLC

(57) **CLAIM**

The ornamental design for a welding apparatus, as shown and described.

DESCRIPTION

FIG. 1 is a top front perspective view of a welding apparatus in a first position showing my new design.

FIG. 2 is a top rear perspective view of the welding apparatus as shown in FIG. 1 showing my new design.

FIG. 3 is a top plan view of the welding apparatus as shown in FIG. 1 showing my new design.

FIG. 4 is a rear elevation view of the welding apparatus as shown in FIG. 1 showing my new design.

FIG. 5 is a first end elevation view of the welding apparatus as shown in FIG. 1 showing my new design.

FIG. 6 is a second end elevation view of the welding apparatus as shown in FIG. 1 showing my new design.

FIG. 7 is a top rear perspective view of the welding apparatus as shown in FIG. 1 in a second position showing my new design.

FIG. 8 is a top front perspective view of the welding apparatus as shown in FIG. 1 including an orbital welder and a cover in an open position showing my new design.

FIG. 9 is a top rear perspective view of the welding apparatus as shown in FIG. 8 with the cover in a closed position showing my new design.

FIG. 10 is a top plan view of the welding apparatus as shown in FIG. 8 showing my new design.

FIG. 11 is a front elevation view of the welding apparatus as shown in FIG. 8 showing my new design.

FIG. 12 is a first end elevation view of the welding apparatus as shown in FIG. 8 showing my new design.

FIG. 13 is a second end elevation view of the welding apparatus as shown in FIG. 8 showing my new design; and,

FIG. 14 is a top front perspective view of the welding apparatus as shown in FIG. 8 with the cover in a closed position showing my new design.

1 Claim, 10 Drawing Sheets

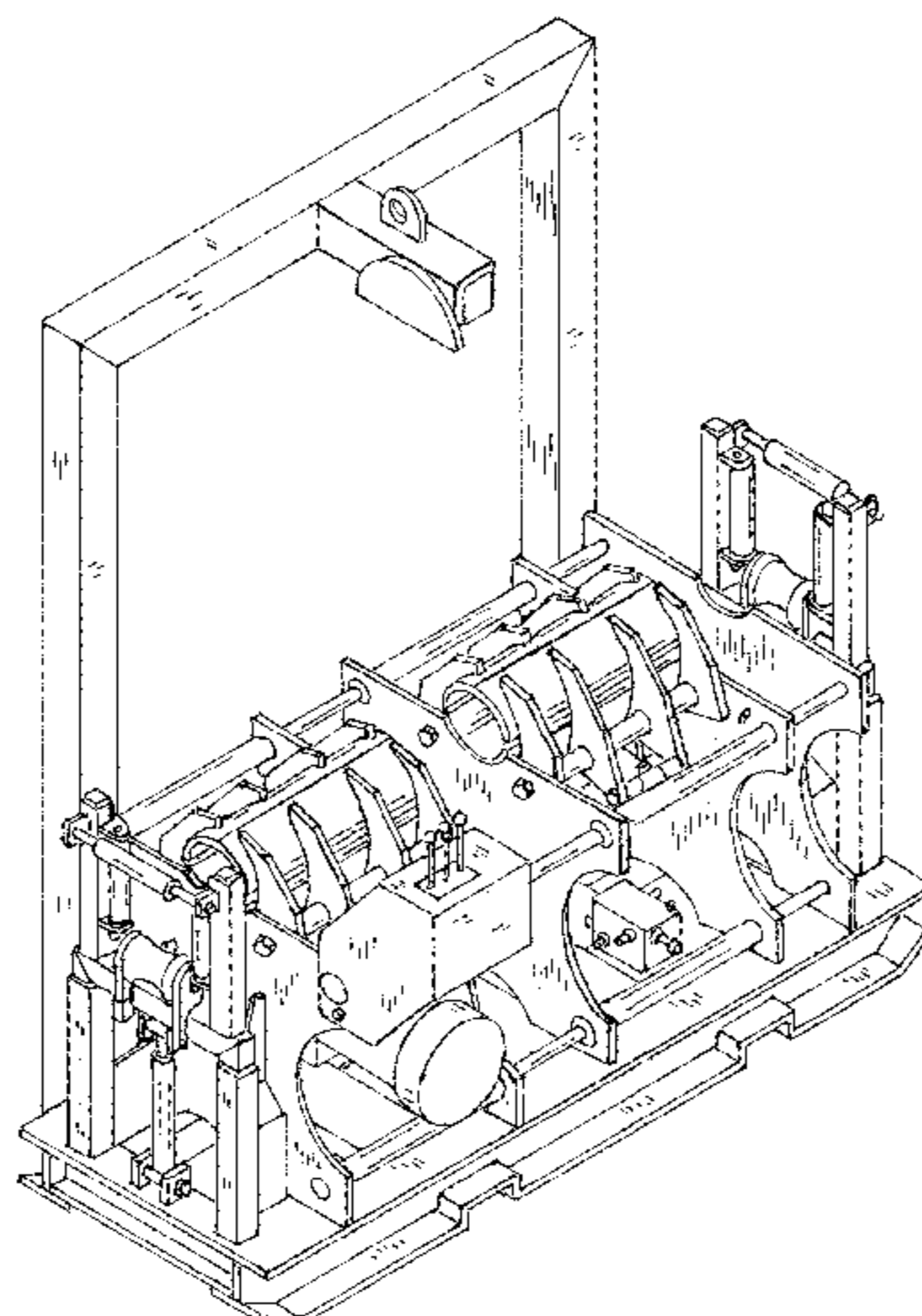

(58) **Field of Classification Search**
 CPC ... B23K 37/0533; B29C 53/20; B29C 65/106;
 B29C 65/782; B29C 65/784; B29C
 65/7802; B29C 66/0222; B29C 66/1142;
 B29C 66/5221; B29C 66/00141
 See application file for complete search history.

6,367,788 B1 * 4/2002 Babchuk B23K 37/0443
 269/45
 6,431,534 B1 8/2002 Orosz et al.
 7,161,115 B2 1/2007 Stecher et al.
 9,434,030 B2 9/2016 Page

(56) **References Cited**
 U.S. PATENT DOCUMENTS

JP 10047536 2/1998
 JP 2006281217 A 10/2006

FOREIGN PATENT DOCUMENTS

3,196,245 A 7/1965 Nelson et al.
 3,284,883 A 11/1966 Boyd et al.
 3,596,898 A 8/1971 Hilburn
 3,653,574 A 4/1972 Dearman
 3,785,160 A 1/1974 Banjavich et al.
 3,828,413 A 8/1974 Cooper et al.
 3,870,288 A 3/1975 McLamon
 3,881,715 A 5/1975 Creek
 3,894,326 A 7/1975 Merriman
 4,009,360 A 2/1977 Beetham
 4,192,167 A 3/1980 Huebner et al.
 4,263,084 A 4/1981 Takala
 4,356,615 A 11/1982 Dearman
 4,716,271 A 12/1987 Hulsizer
 5,040,716 A 8/1991 Stetz
 5,356,067 A * 10/1994 Leduc B23K 37/0531
 228/212
 5,732,455 A 3/1998 Diede
 5,738,386 A 4/1998 Barefoot et al.
 5,814,182 A * 9/1998 McElroy, II B29C 65/2084
 156/304.2
 5,830,312 A * 11/1998 Weimer B25B 5/003
 156/158
 5,837,966 A * 11/1998 Timmons, Jr. B23K 9/0286
 219/124.34
 5,865,430 A * 2/1999 Conover B23K 37/0533
 228/49.3
 6,212,747 B1 4/2001 Porter et al.
 6,212,748 B1 4/2001 Porter et al.

OTHER PUBLICATIONS

Huisman Equipment, Line-up Systems, accessed Feb. 3, 2012,
[http://www.huismanequipment.com/en/products/
 pipelay_components/lineup_systems](http://www.huismanequipment.com/en/products/pipelay_components/lineup_systems).
 Magnatech Orbital Welding Systems, The Autoweld System-Orbital
 Welding Equipment/Automated Welding Equipment, [www.
 magnatech-ip.com](http://www.magnatech-ip.com).
 AMI, Arc Machines, Inc., www.arcmachines.com.
 Pro-Fusion, Accu-Fit Tub Alignment Clamps, [www.pro-
 fusiononline.com](http://www.pro-fusiononline.com).
 McElroy, McElroy's Operator's Manual No. 412 & No. 618 Fusion
 Machines, www.mcelroy.com.
 Mannion, Bernards, "The Fundamentals of Orbital Welding," Weld-
 ing Design & Fabrication Magazine, Feb. 1999.
 Justin V. Page, International Application No. PCT/CA2009/001665,
 International Search Report and Written Opinion, dated Feb. 2,
 2010.
 Zap-Lok, Zap-Lok Pipeline Systems, Inc., [http://zap-lok.com/
 works.html](http://zap-lok.com/works.html), printed Jun. 29, 2010.
 U.S. Appl. No. 12/619,252, Office Action, dated Aug. 20, 2012.
 U.S. Appl. No. 12/619,252, Final Office Action, dated Apr. 18, 2013.
 U.S. Appl. No. 12/619,252, Office Action, dated Jan. 9, 2014.
 U.S. Appl. No. 12/619,252, Final Office Action, dated Aug. 7, 2014.
 U.S. Appl. No. 12/619,252, Office Action, dated Jun. 23, 2015.

* cited by examiner

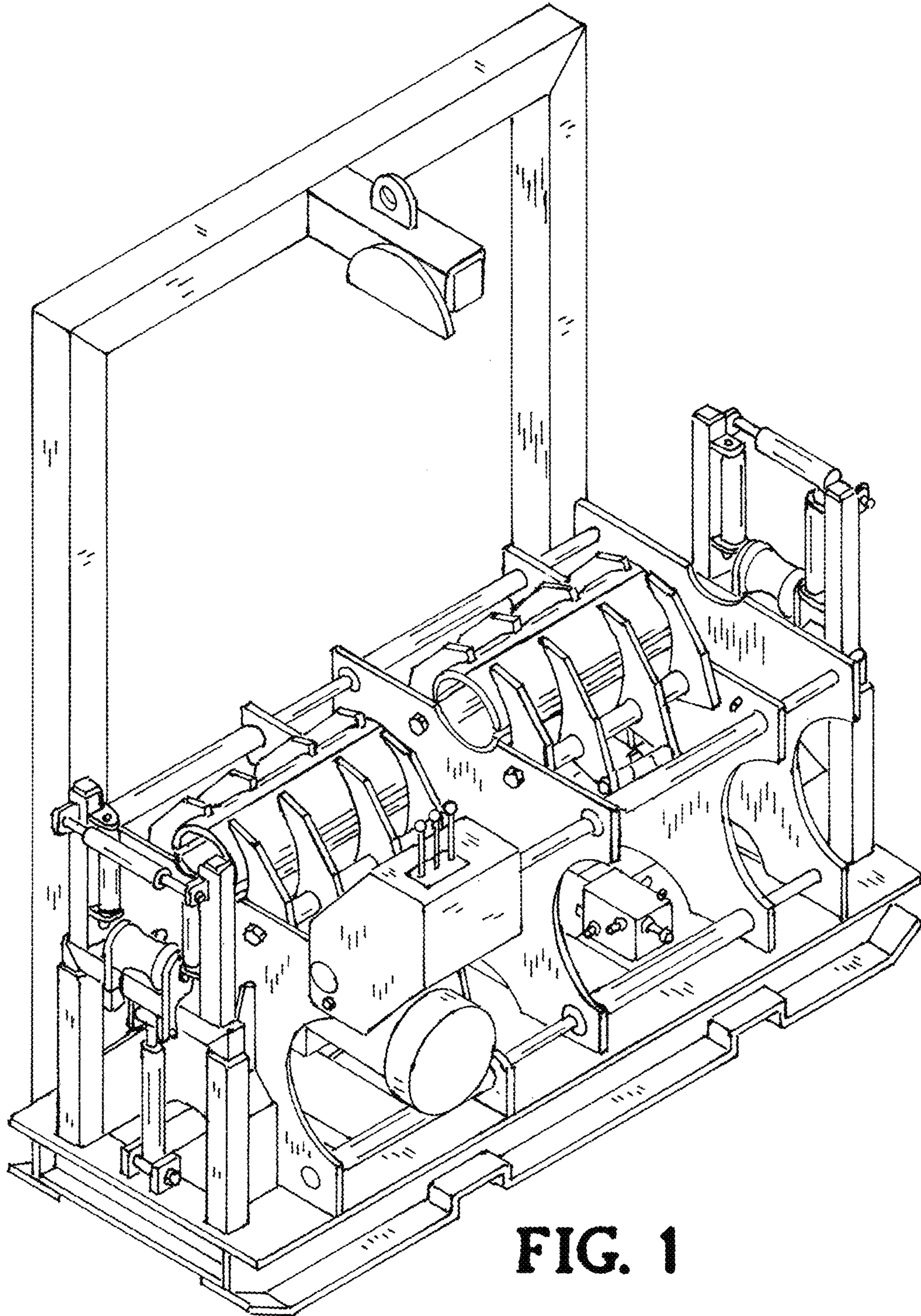

FIG. 1

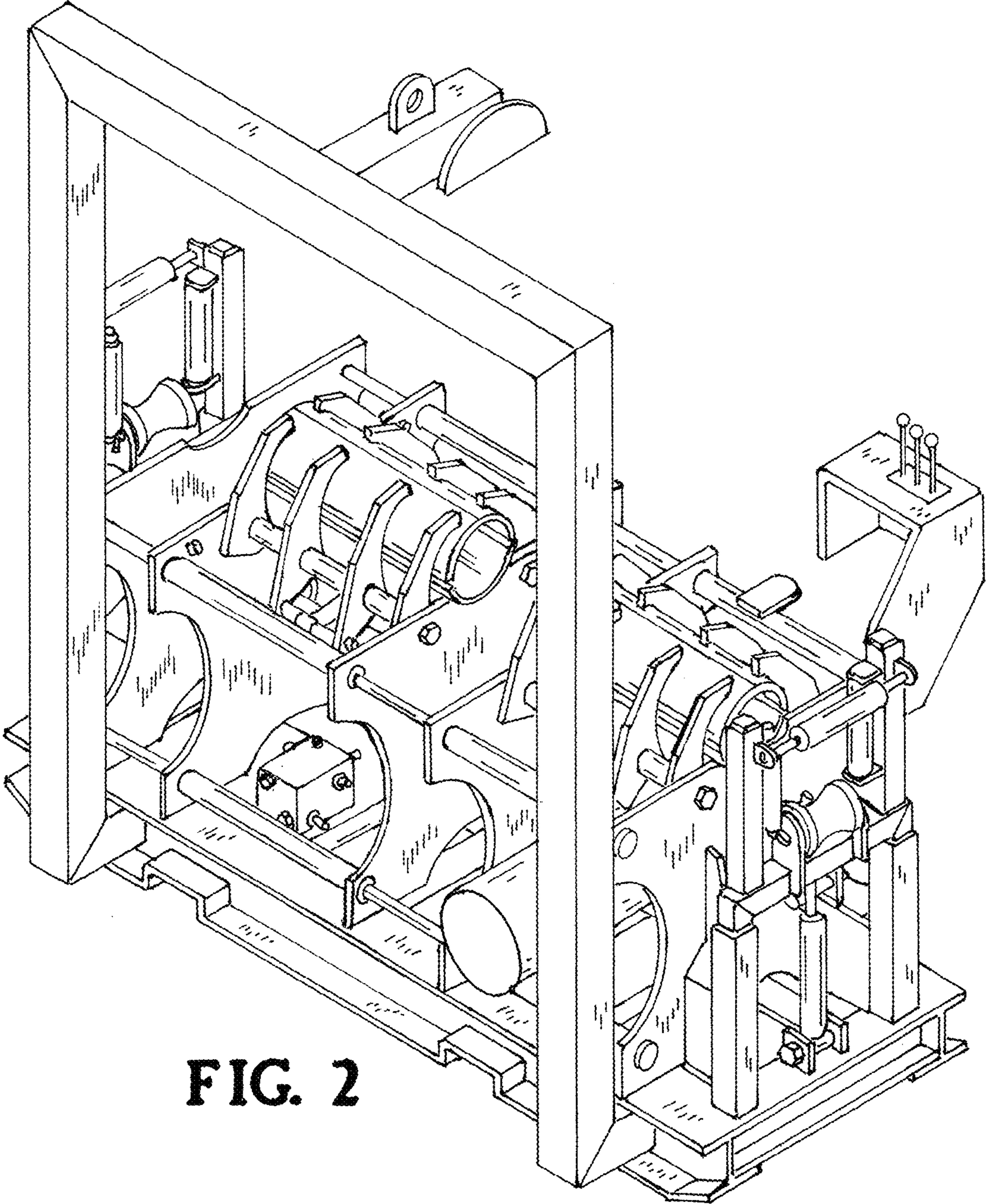

FIG. 2

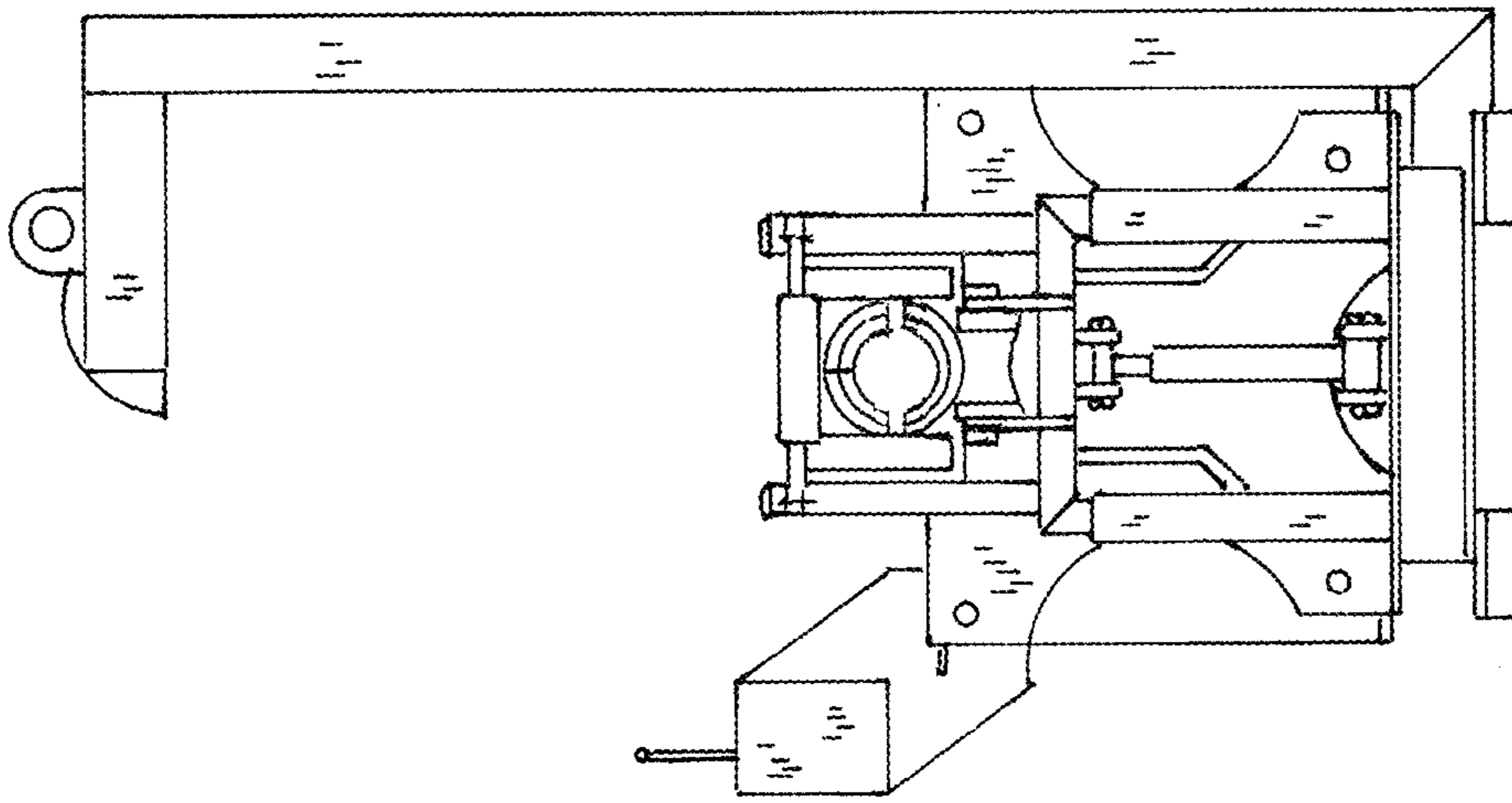

FIG. 6

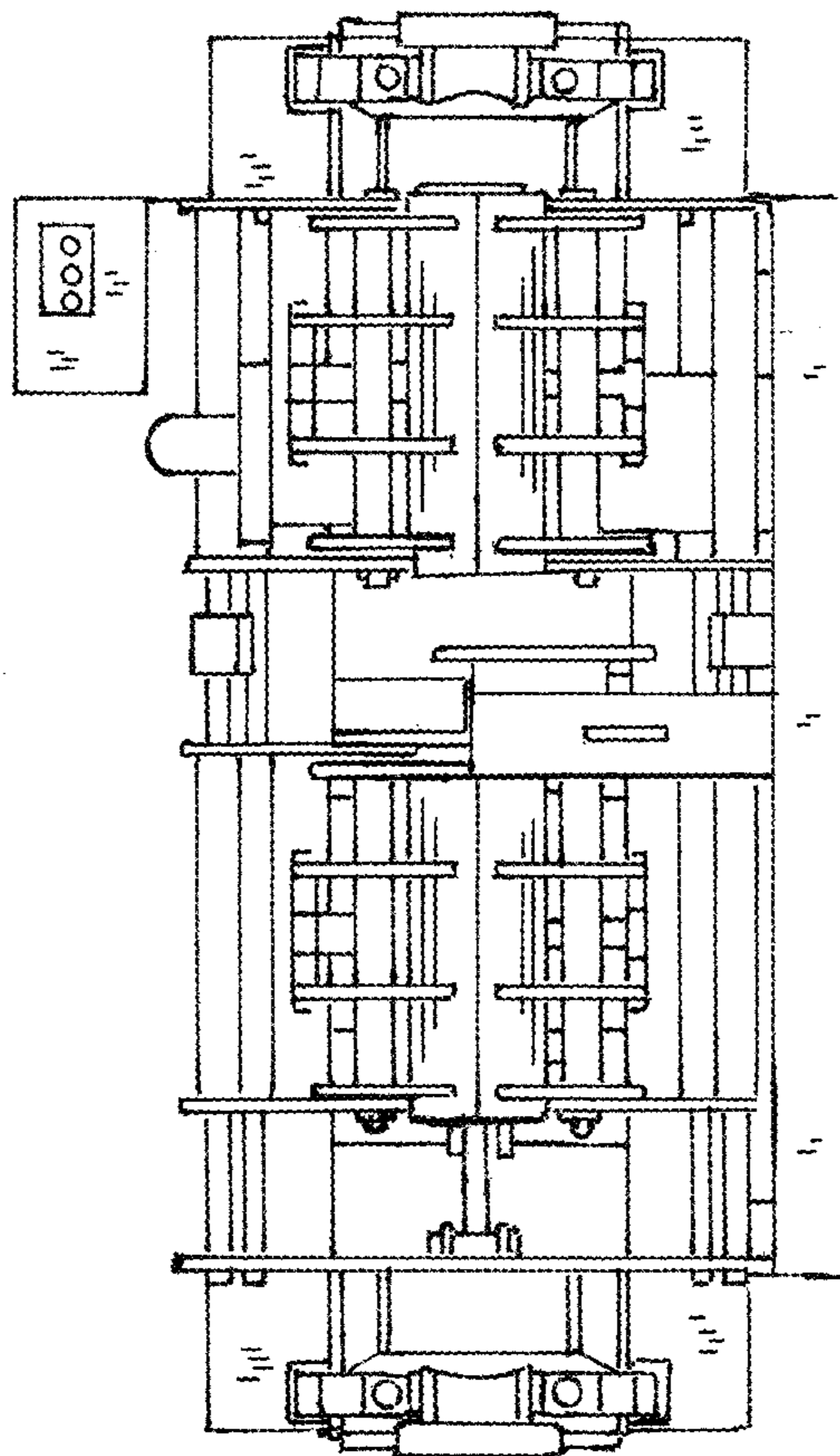

FIG. 3

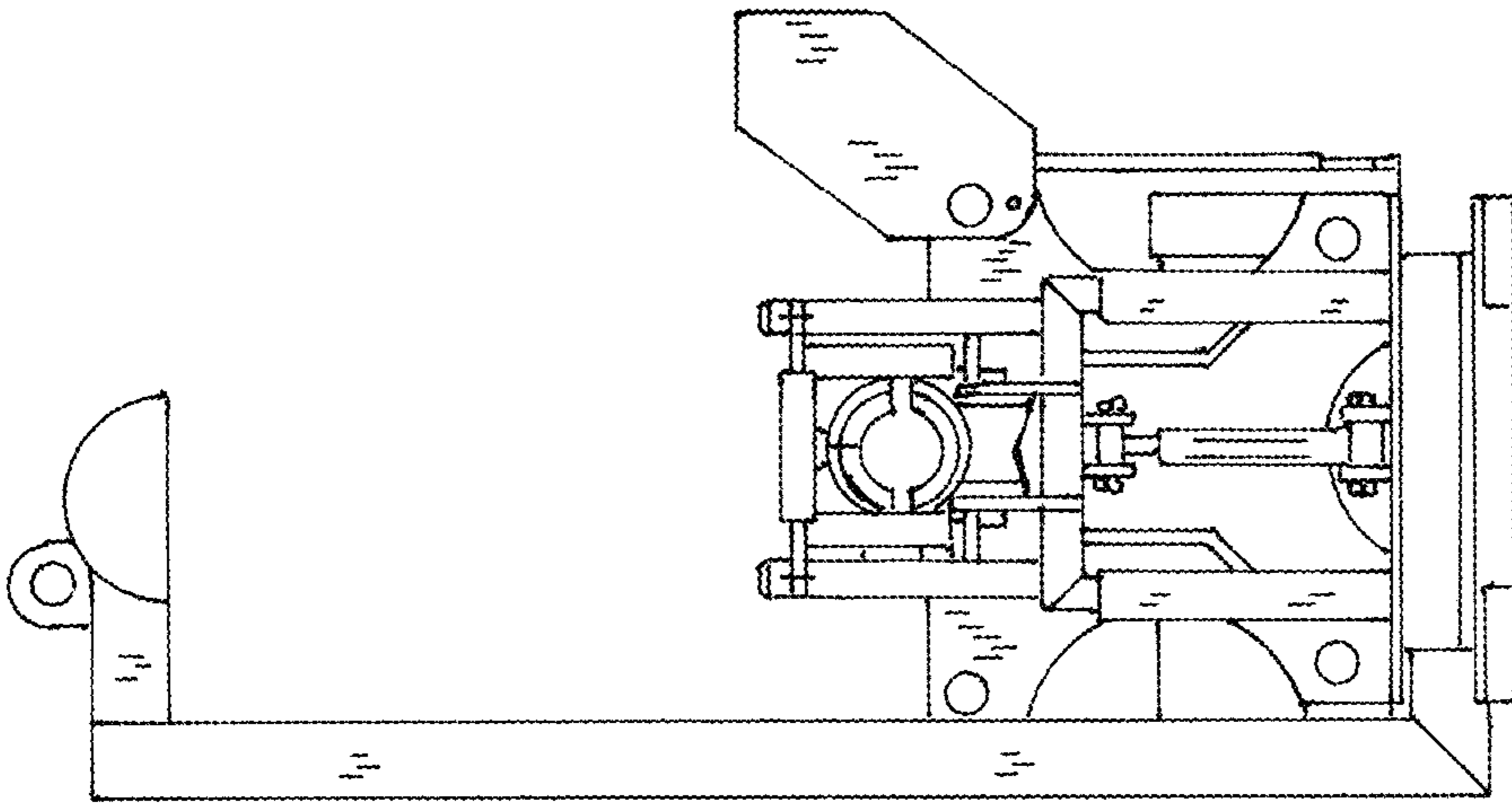

FIG. 5

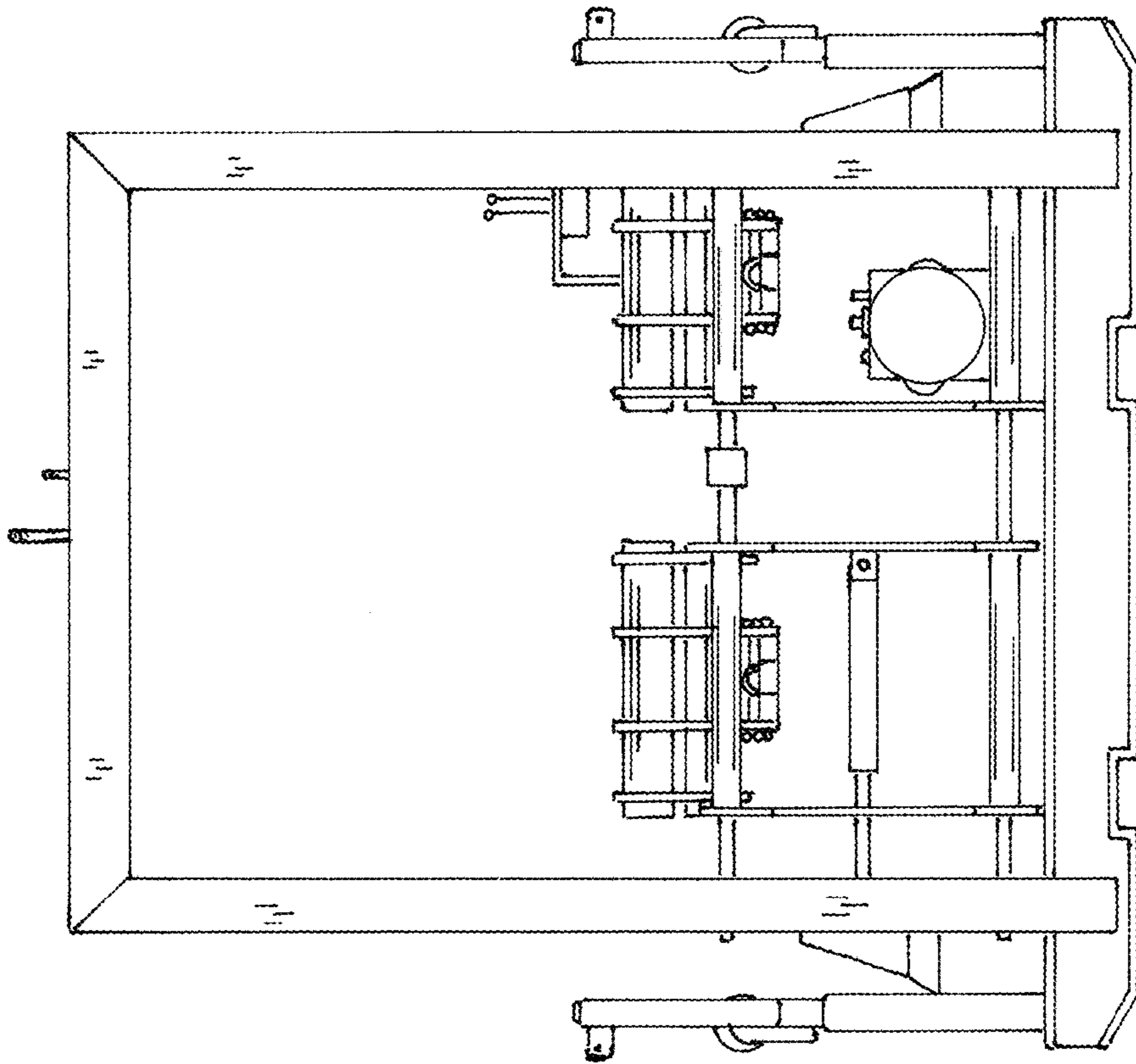

FIG. 4

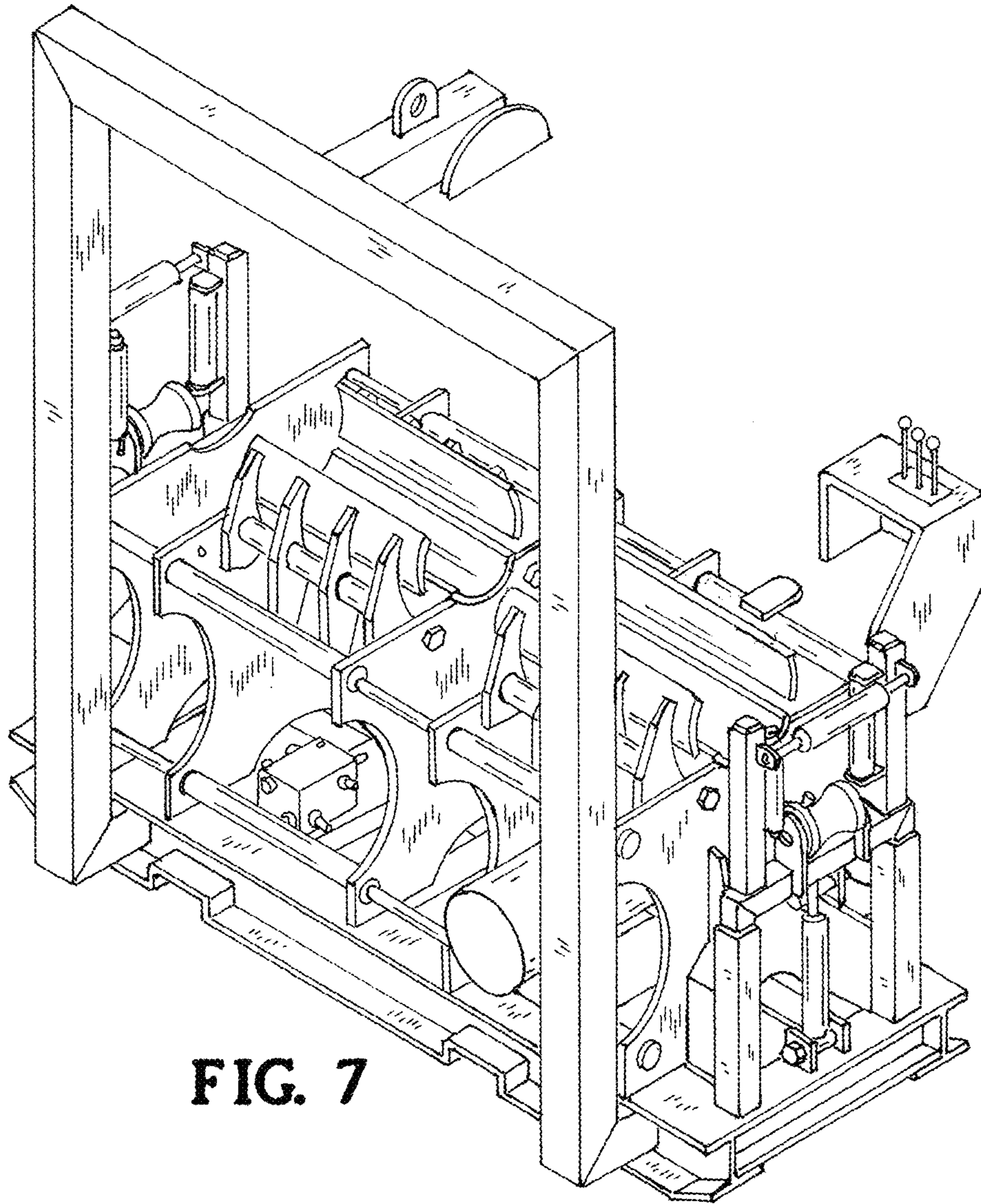

FIG. 7

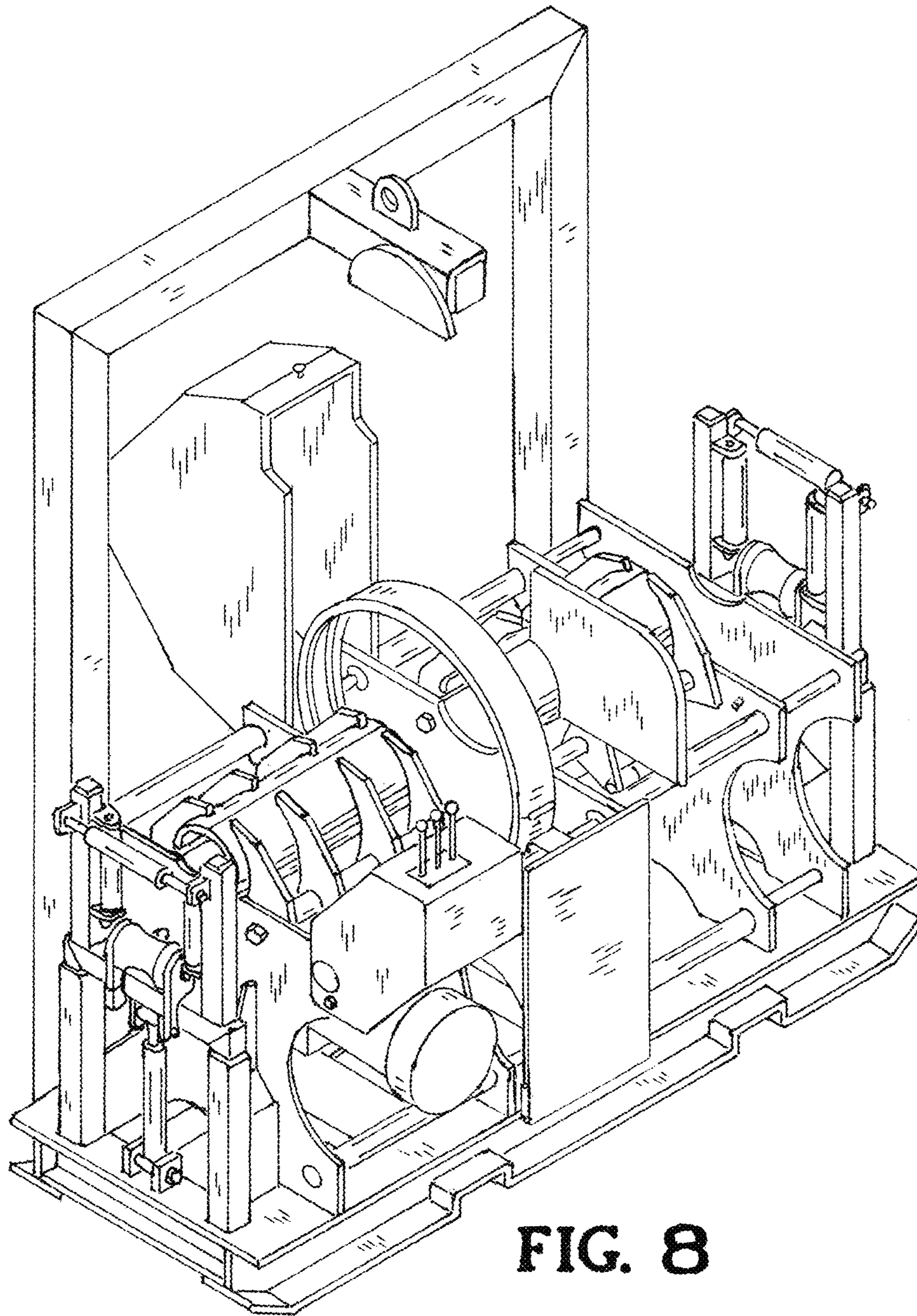

FIG. 8

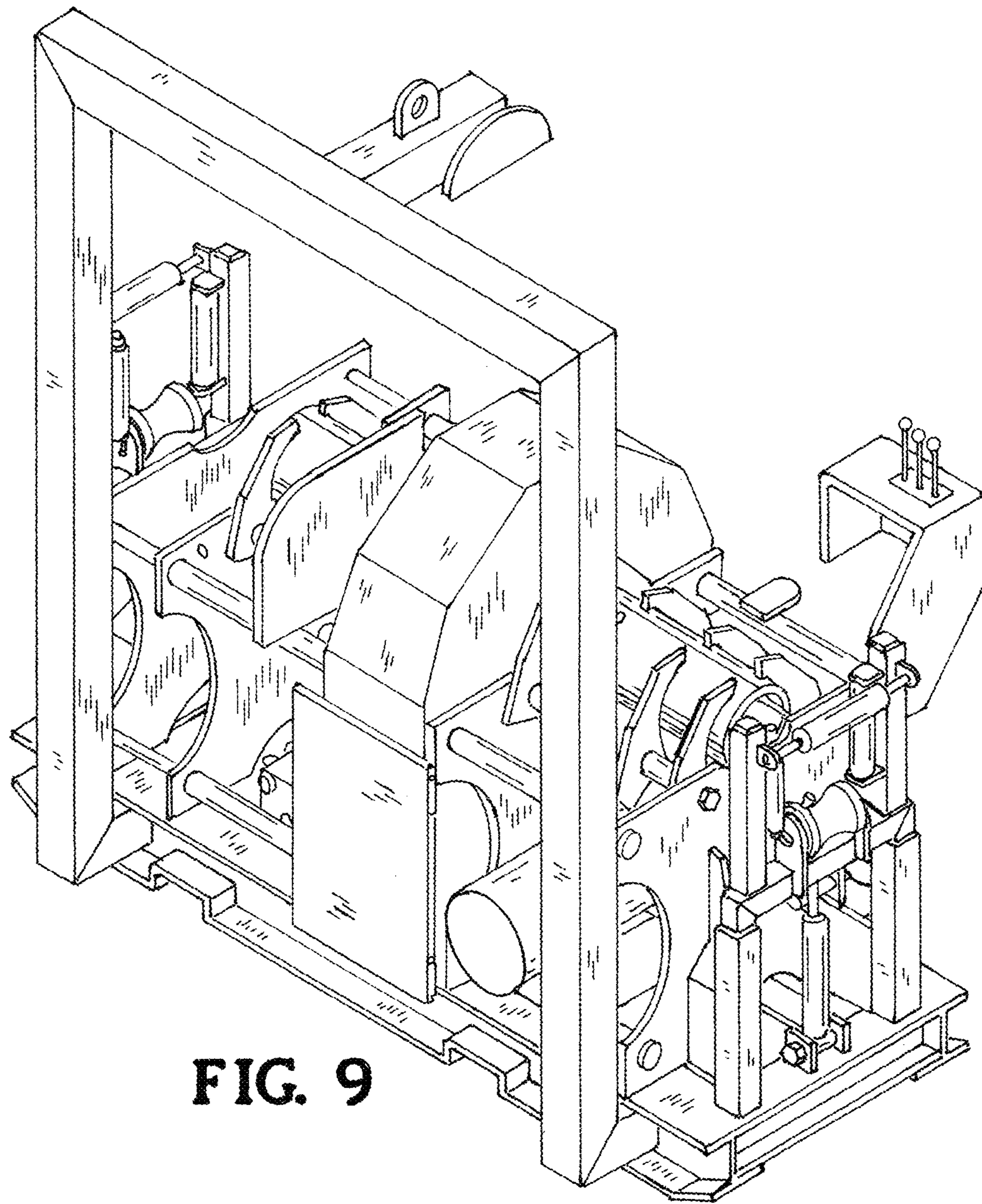

FIG. 9

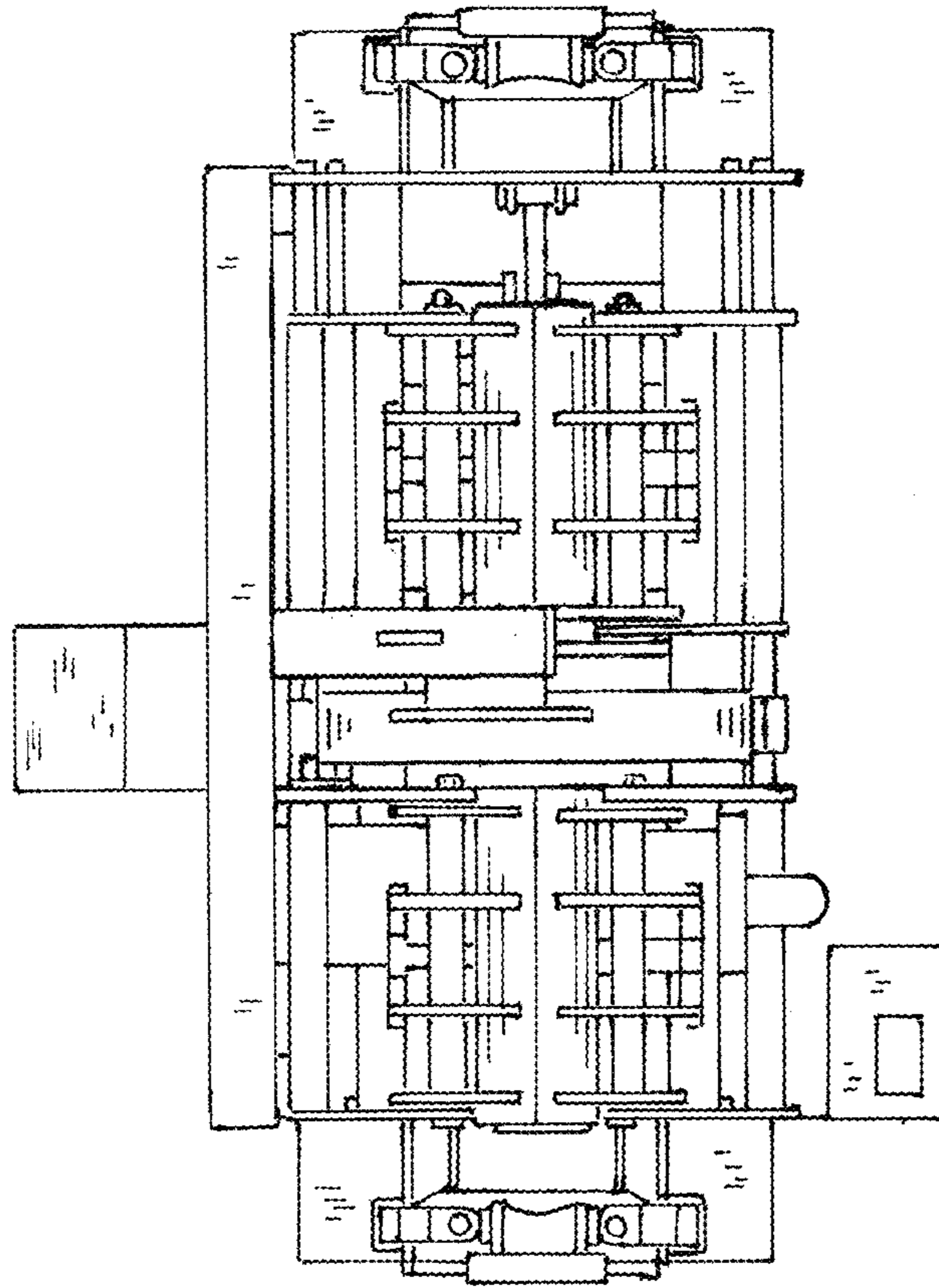

FIG. 10

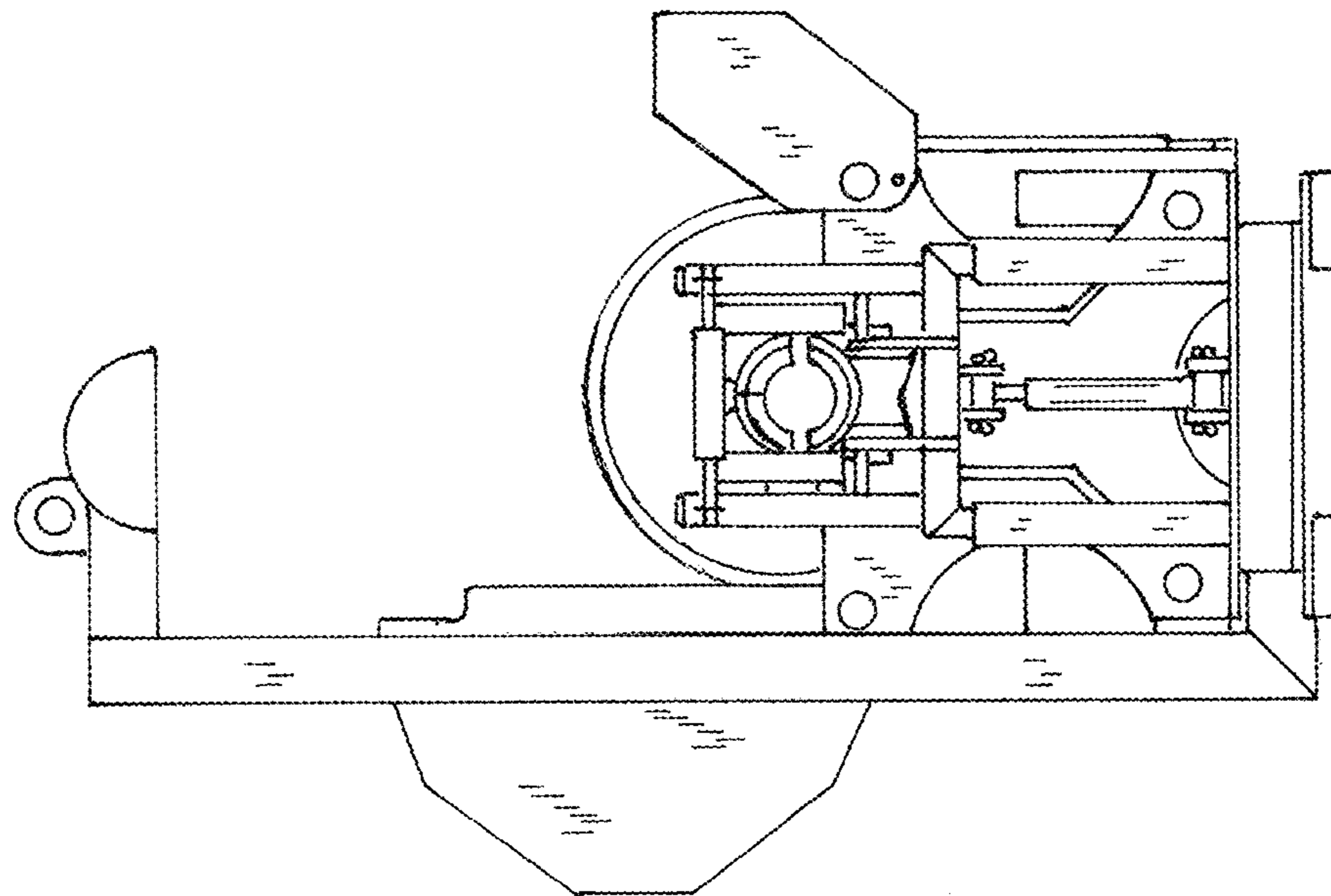

FIG. 12

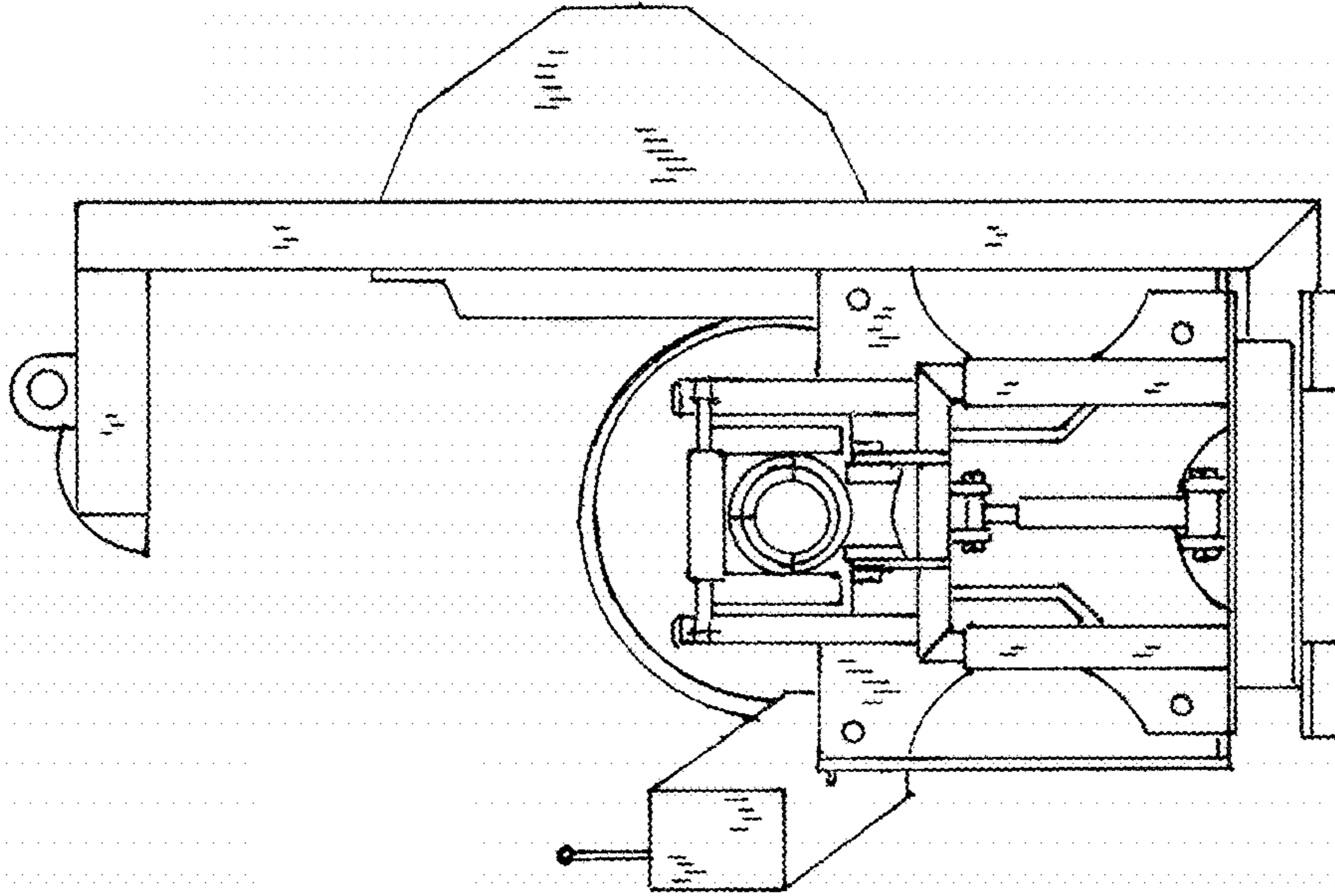

FIG. 13

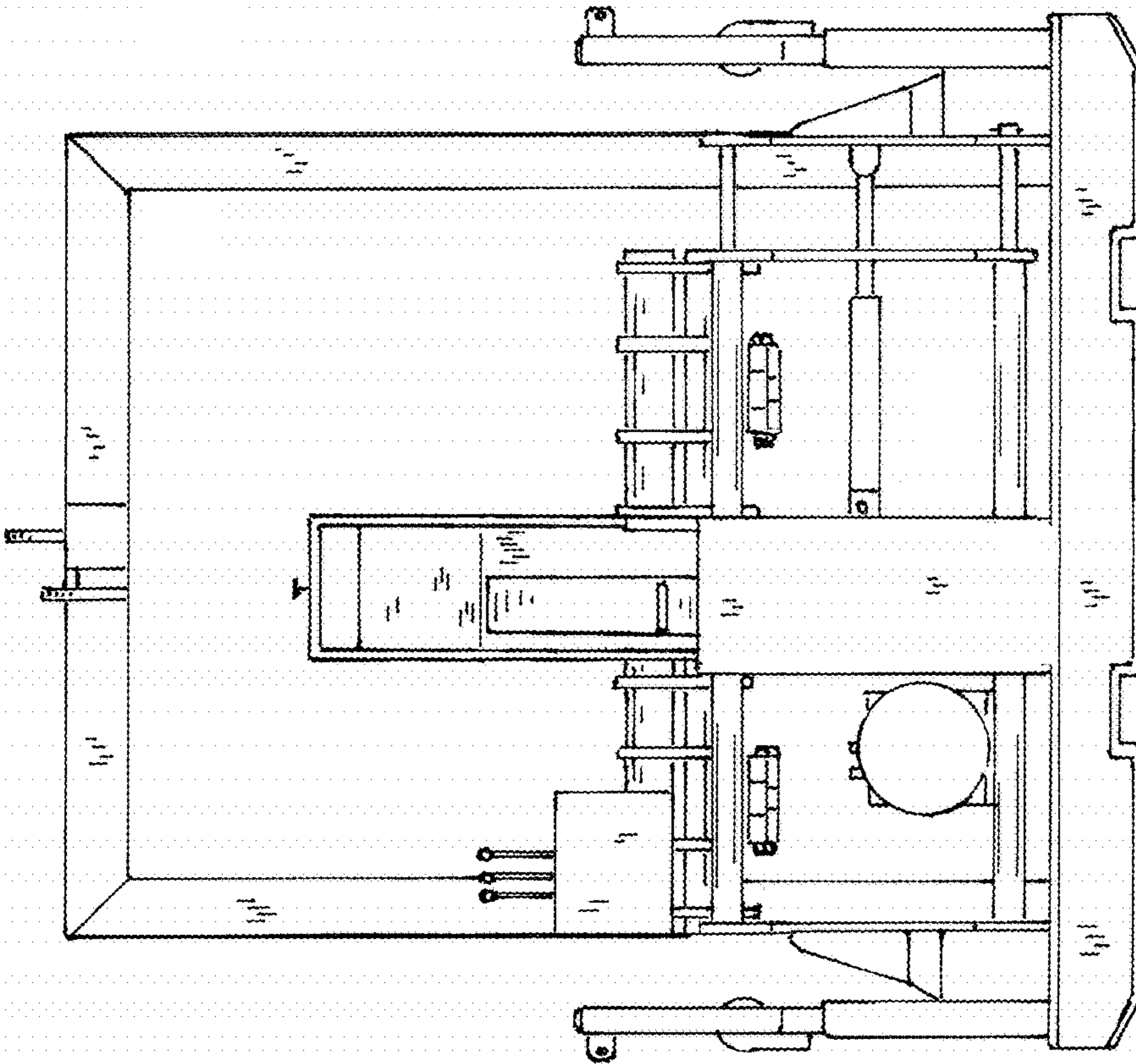

FIG. 11

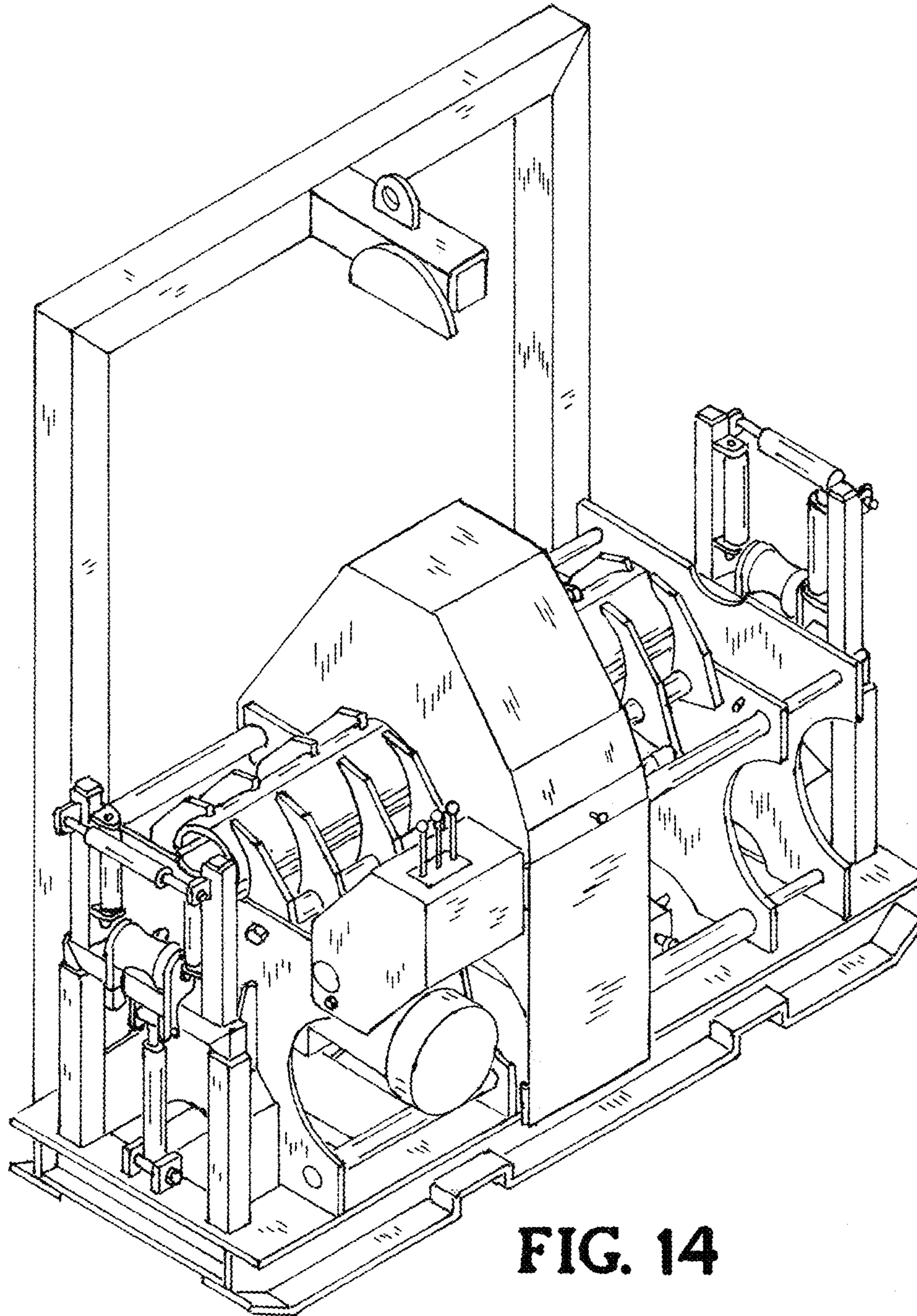

FIG. 14