



US00D813987S

(12) **United States Design Patent**
Schoenherr et al.

(10) **Patent No.:** **US D813,987 S**
(45) **Date of Patent:** **** Mar. 27, 2018**

- (54) **FAUCET**
- (71) Applicant: **HANSGROHE SE**, Schiltach (DE)
- (72) Inventors: **Tom Schoenherr**, Stuttgart (DE);
Andreas Diefenbach,
Ludwigsburg-Oßweil (DE)
- (73) Assignee: **Hansgrohe SE**, Schiltach (DE)
- (**) Term: **15 Years**
- (21) Appl. No.: **29/587,614**
- (22) Filed: **Dec. 14, 2016**
- (30) **Foreign Application Priority Data**

D541,385 S *	4/2007	Haug	D23/252
D644,302 S *	8/2011	Flowers	D23/238
D666,276 S *	8/2012	Fritz	D23/238

FOREIGN PATENT DOCUMENTS

CN	302011504	7/2012
CN	302031611	8/2012
CN	302203653	11/2012
EM	000214952-0001	8/2004
EM	000214952-0002	8/2004
EM	000214952-0003	8/2004
EM	000214952-0004	8/2004
EM	000214952-0005	8/2004
EM	000214952-0006	8/2004
EM	000214952-0007	8/2004
EM	000214952-0008	8/2004
EM	000214952-0009	8/2004
EM	000214952-0010	8/2004

* cited by examiner

Primary Examiner — Robert A Delehanty

(74) *Attorney, Agent, or Firm* — Lora J. Graentzdoerffer

(57) **CLAIM**

The ornamental design for a faucet, as shown and described.

DESCRIPTION

FIG. 1 is a perspective view;
 FIG. 2 is a front elevation view;
 FIG. 3 is a rear elevation view;
 FIG. 4 is a right side elevation view;
 FIG. 5 is a left side elevation view;
 FIG. 6 is a top plan view; and,
 FIG. 7 is a bottom plan view.
 The broken lines indicate portions of the faucet that form no part of the claimed design.

1 Claim, 7 Drawing Sheets

- Jun. 20, 2016 (EM) 003229848-0010
- (51) **LOC (11) Cl.** **23-01**
- (52) **U.S. Cl.**
USPC **D23/238**
- (58) **Field of Classification Search**
USPC D23/238–243, 249–250, 252, 254–255,
D23/257; D8/307–308, 310
CPC Y10T 137/9464
See application file for complete search history.

(56) **References Cited**

U.S. PATENT DOCUMENTS

D291,238 S *	8/1987	Haug	D23/252
D331,450 S *	12/1992	Haug	D23/252
D342,988 S *	1/1994	Jans	D23/252
D441,840 S *	5/2001	Meylan	D23/238
D479,579 S *	9/2003	Haug	D23/238
D535,360 S *	1/2007	Noth	D23/238

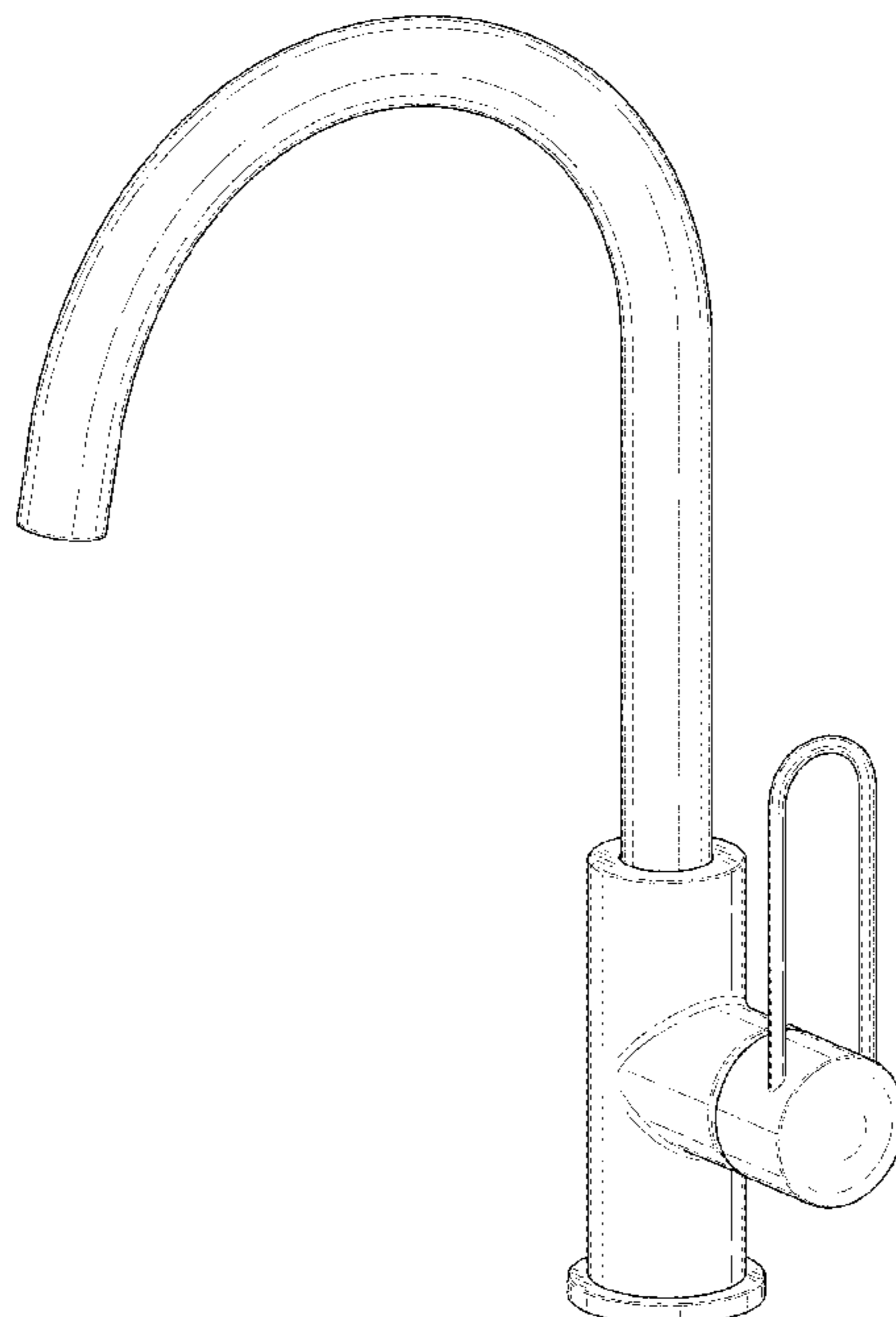

FIG. 1

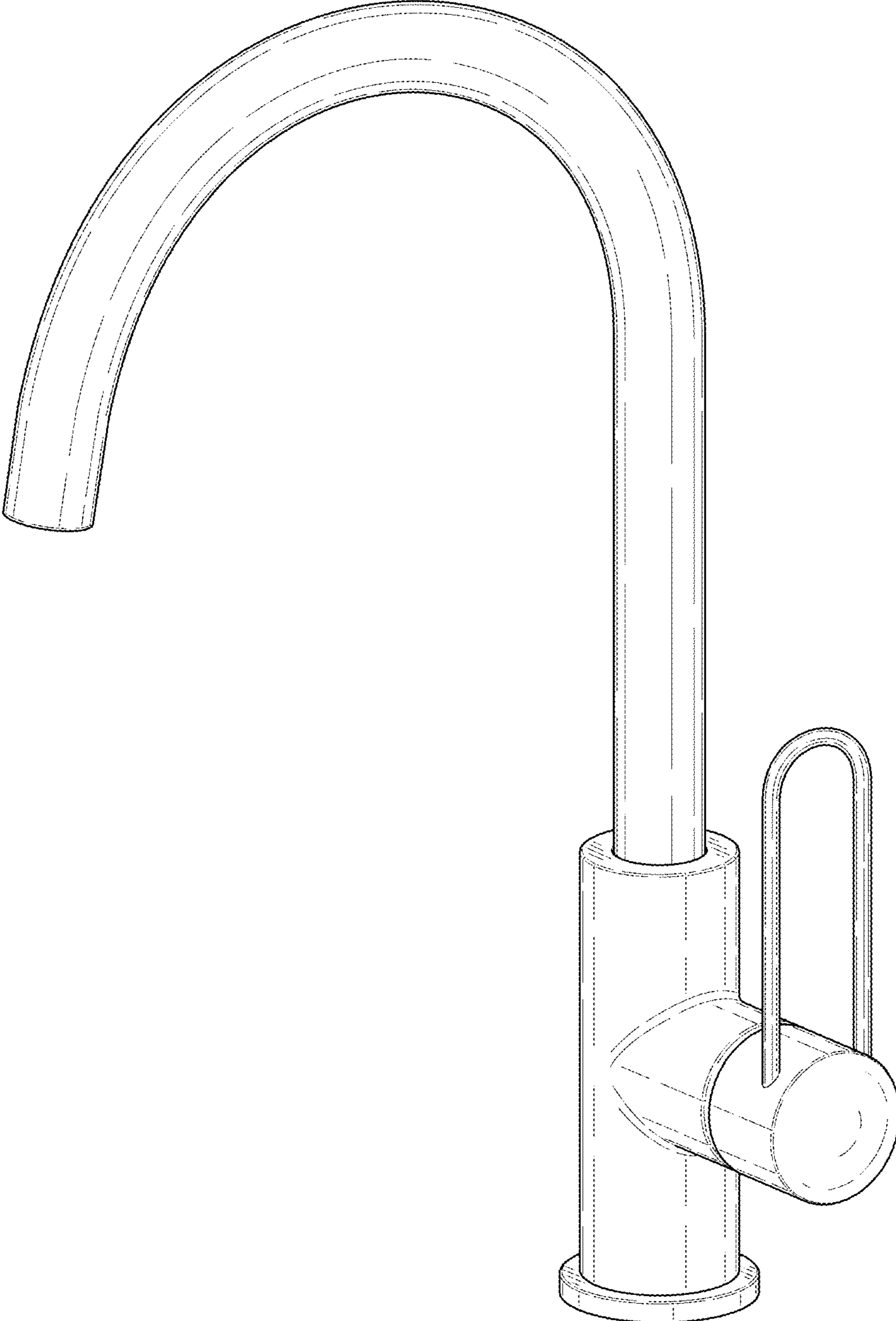

FIG. 2

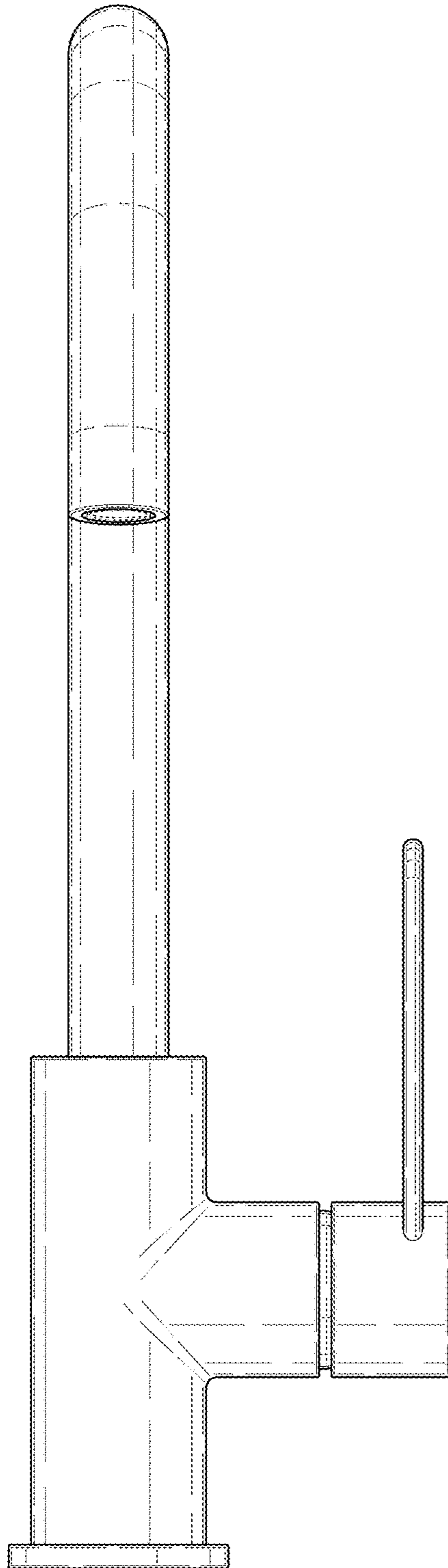

FIG. 3

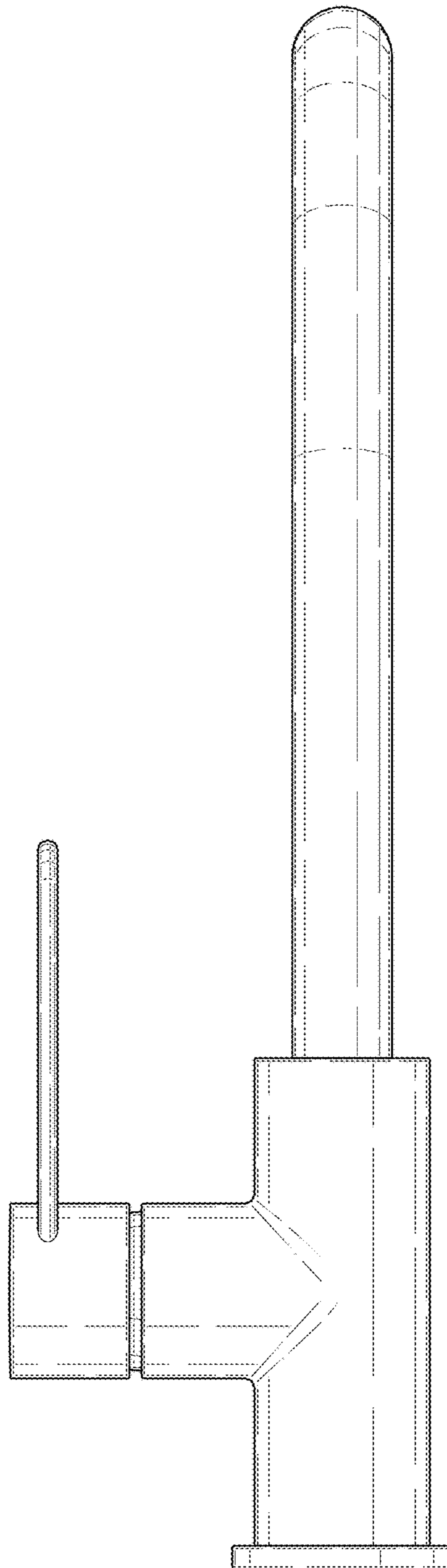

FIG. 4

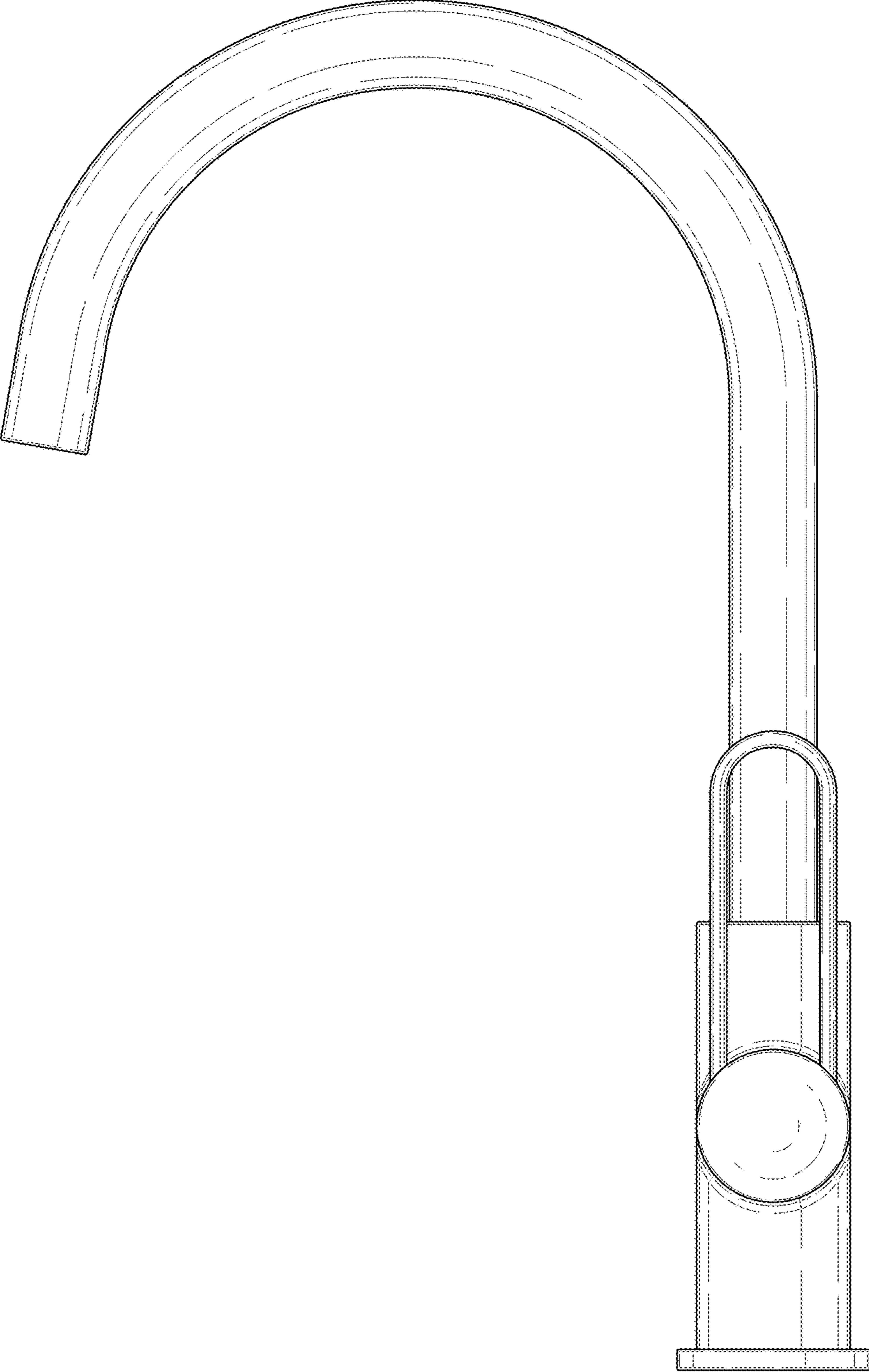

FIG. 5

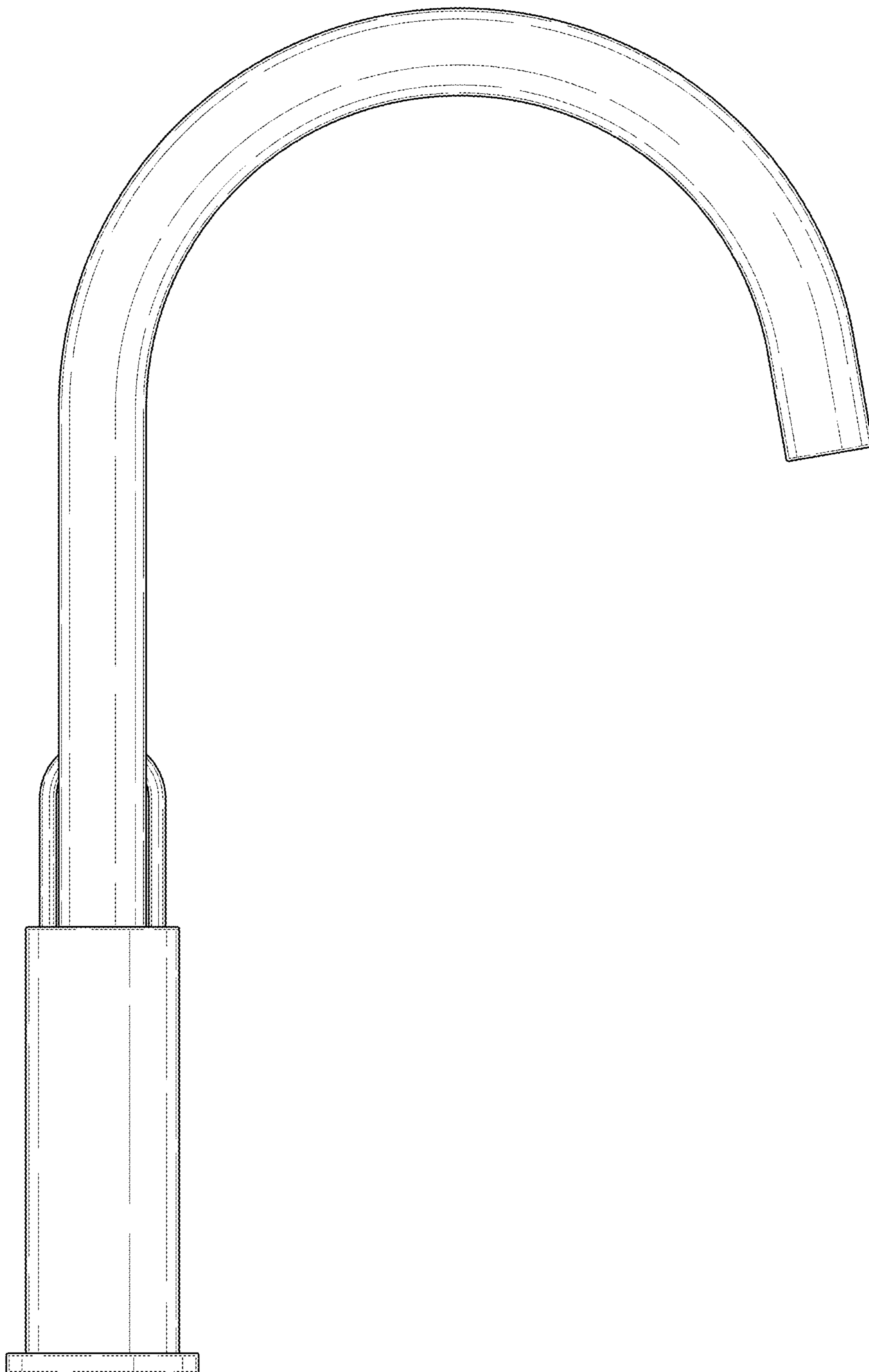

FIG. 6

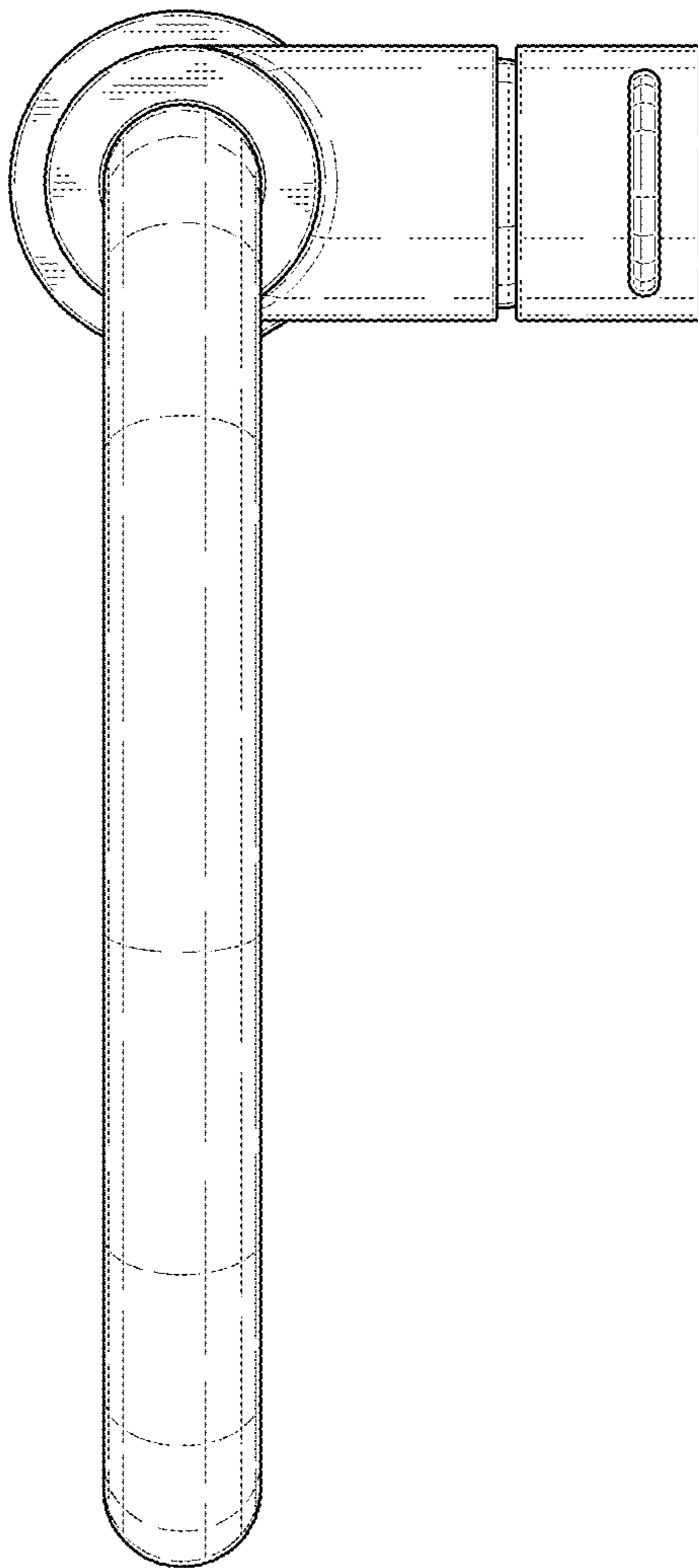

FIG. 7

