



US00D813787S

(12) **United States Design Patent**  
**Thomas**

(10) **Patent No.:** **US D813,787 S**  
(45) **Date of Patent:** **\*\* Mar. 27, 2018**

(54) **CARGO RACK**  
(71) Applicant: **Ronald D. Thomas**, Emmett, ID (US)  
(72) Inventor: **Ronald D. Thomas**, Emmett, ID (US)  
(\*\*) Term: **15 Years**  
(21) Appl. No.: **29/567,826**  
(22) Filed: **Jun. 13, 2016**  
(51) **LOC (11) Cl.** ..... **12-16**  
(52) **U.S. Cl.**  
USPC ..... **D12/414**  
(58) **Field of Classification Search**  
USPC .... D12/93, 94, 95, 96, 97, 98, 99, 100, 400,  
D12/406, 412, 413, 414, 414.1, 101, 102,  
D12/103, 104, 105, 106  
CPC .. B60P 3/34; B60P 3/341; B60P 3/222; B60P  
3/224; B60P 1/04; B60P 1/435; B60P  
1/56; B62B 3/022; B62D 63/061; B62D  
21/20; B62D 33/037; B60D 1/155; B61D  
7/00; B61D 7/02; B23K 31/02  
See application file for complete search history.

D336,870 S \* 6/1993 Thacker ..... D12/101  
5,480,180 A \* 1/1996 Fuller ..... B62D 21/20  
280/491.1  
D373,748 S \* 9/1996 Fuller ..... D12/105  
5,628,540 A 5/1997 James  
5,878,695 A \* 3/1999 Gent ..... A01K 1/0209  
119/503  
D418,451 S \* 1/2000 Konecheck ..... D12/101  
D436,915 S 1/2001 Burger  
6,347,731 B1 2/2002 Burger  
D469,388 S \* 1/2003 Mighell ..... D12/101  
7,252,317 B2 \* 8/2007 Boe ..... B62D 33/037  
296/181.1  
D558,097 S \* 12/2007 Winter ..... D12/101  
(Continued)

*Primary Examiner* — Karen S Acker  
*Assistant Examiner* — Jerry Shiuan-Hua Hsu  
(74) *Attorney, Agent, or Firm* — Morriss O’Bryant  
Compagni Cannon, PLLC

(57) **CLAIM**

The ornamental design for a cargo rack, as shown and described.

**DESCRIPTION**

FIG. 1 is a perspective back side view of a cargo rack of the present invention;  
FIG. 2 is a right side view of the cargo rack;  
FIG. 3 is a left side view of the cargo rack;  
FIG. 4 is a back side view of the cargo rack;  
FIG. 5 is a front side view of the cargo rack;  
FIG. 6 is a top side view of the cargo rack; and,  
FIG. 7 is a perspective back side exploded view of the cargo rack.  
The broken lines shown in the drawings depicting the bed of the truck illustrate the unclaimed environment in which the cargo rack is used. The remaining broken lines illustrate portions of the article that are not claimed. None of the broken lines form part of the claimed design.

**1 Claim, 6 Drawing Sheets**

(56) **References Cited**

U.S. PATENT DOCUMENTS

2,531,310 A	11/1950	Tonn	
2,701,927 A	2/1955	Dyer	
2,720,414 A	10/1955	Hart	
2,863,696 A	12/1958	Sigman	
2,947,566 A	8/1960	Tower	
3,475,046 A	10/1969	Webster	
4,211,448 A	7/1980	Weston	
4,405,170 A	9/1983	Raya	
4,779,916 A	10/1988	Christie	
4,906,038 A	3/1990	Morris	
5,037,152 A	8/1991	Hendricks	
5,143,415 A	9/1992	Boudah	
5,152,570 A	10/1992	Hood	
D331,207 S *	11/1992	Phelps	D12/101
5,192,107 A	3/1993	Smith, Sr.	

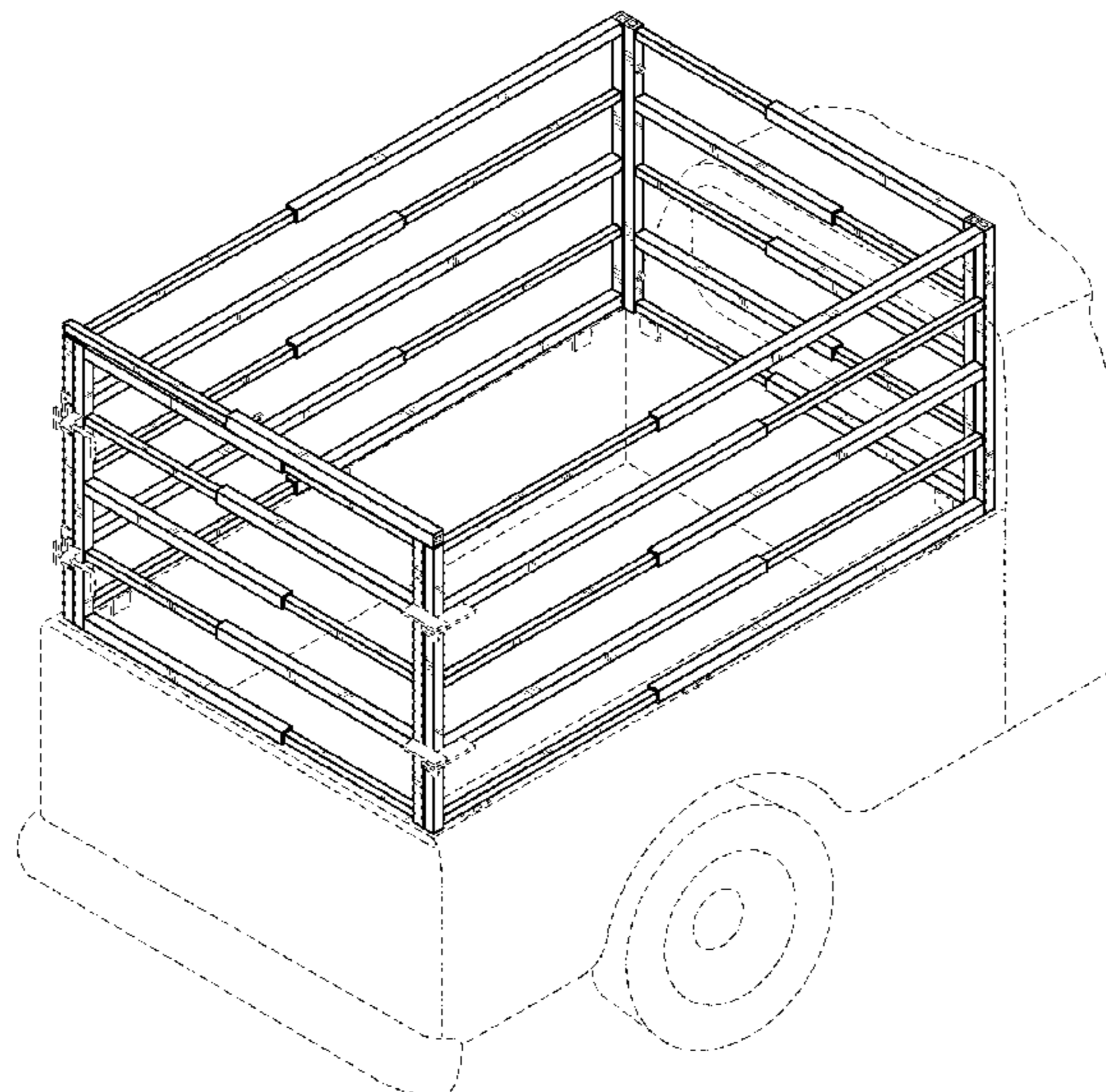

(56)

**References Cited**

U.S. PATENT DOCUMENTS

7,530,614	B2	5/2009	Nichols	
D624,005	S *	9/2010	Winner .....	D12/412
D664,476	S *	7/2012	Fraley .....	D12/105
D779,380	S *	2/2017	van den Berg .....	D12/101
2002/0092881	A1	7/2002	Lambert	
2005/0023314	A1	2/2005	Williams et al.	
2009/0146450	A1	6/2009	Flores	
2010/0223866	A1*	9/2010	Melville .....	A01K 1/0236 52/282.1

\* cited by examiner

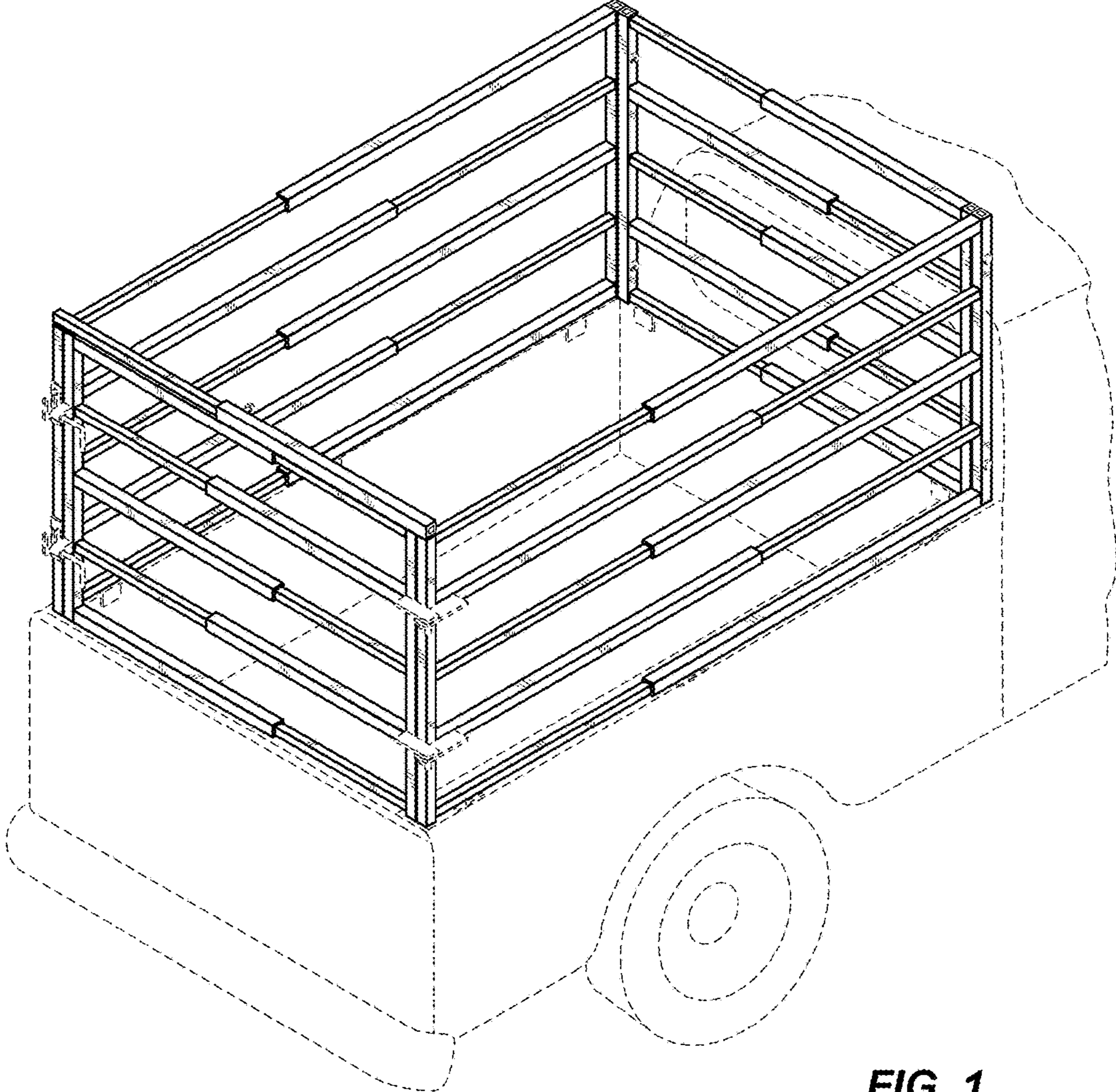

**FIG. 1**

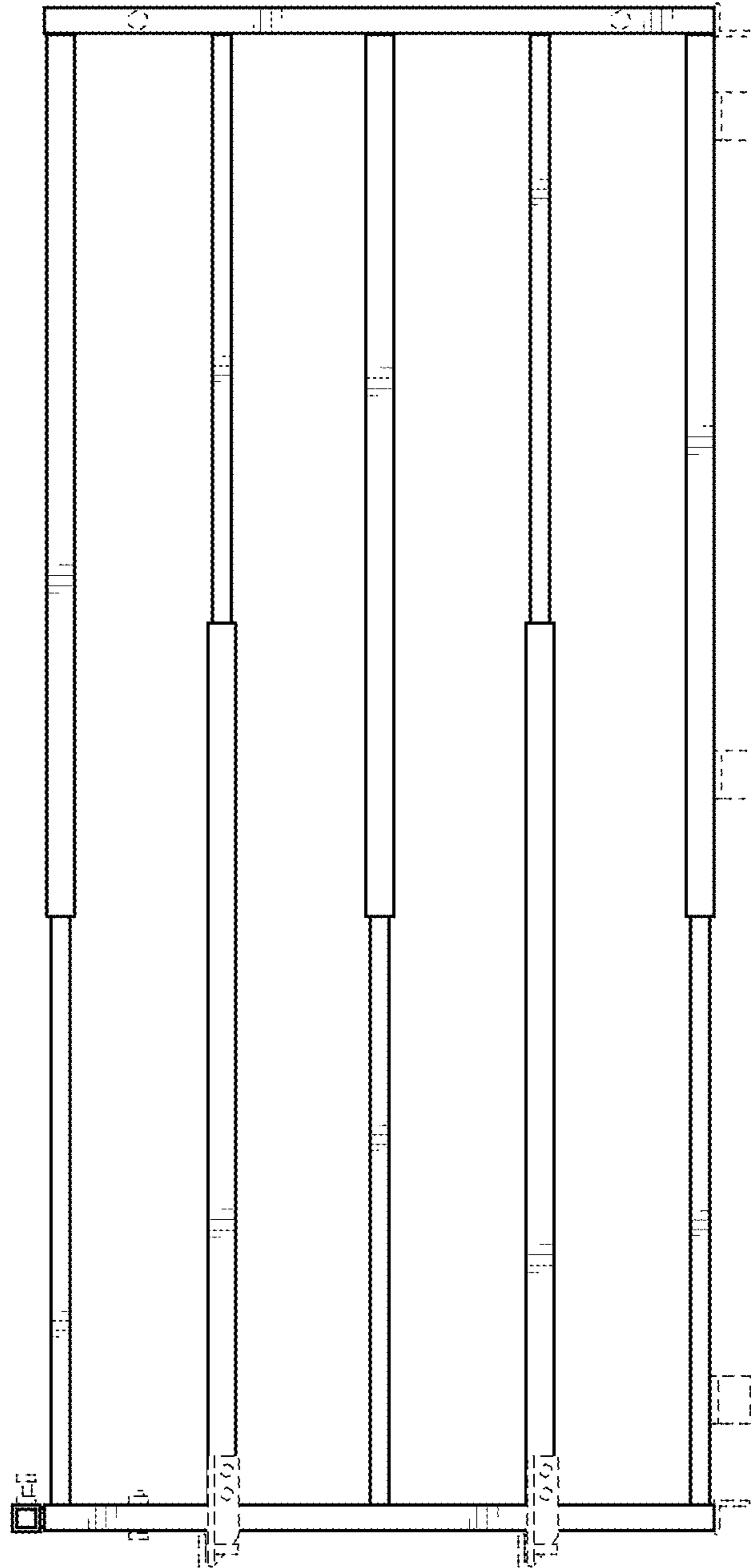
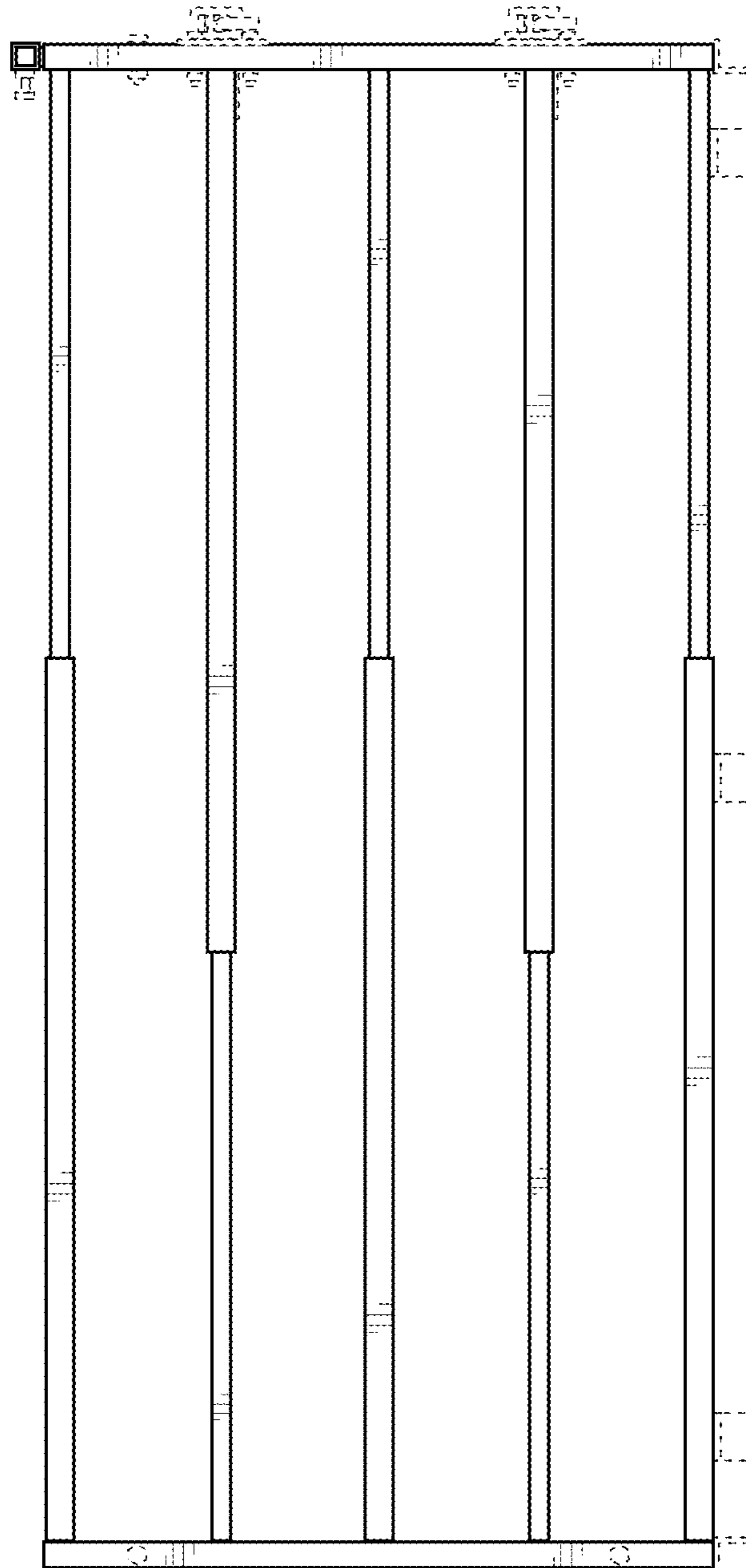
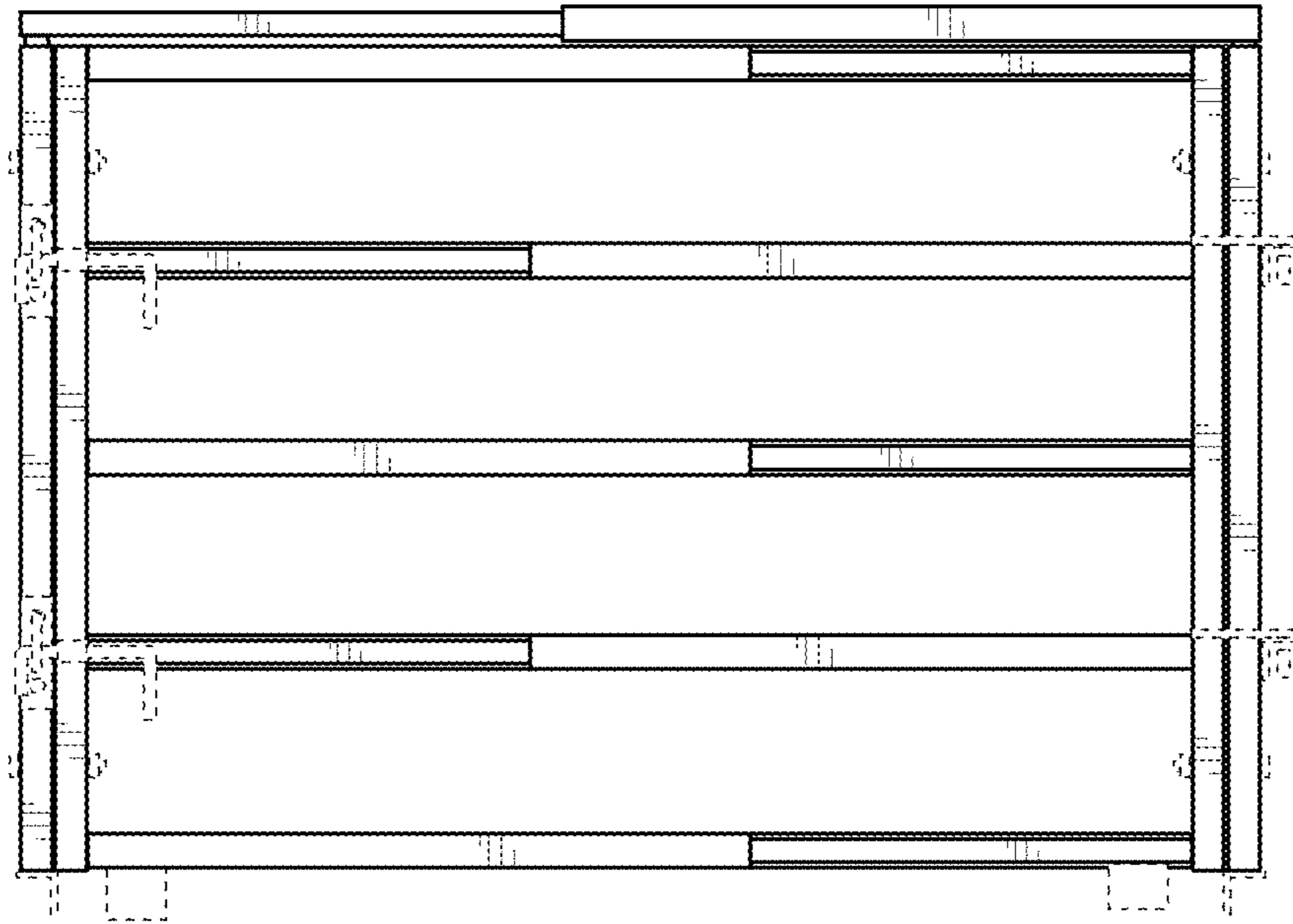

FIG. 2



**FIG. 3**



**FIG. 4**

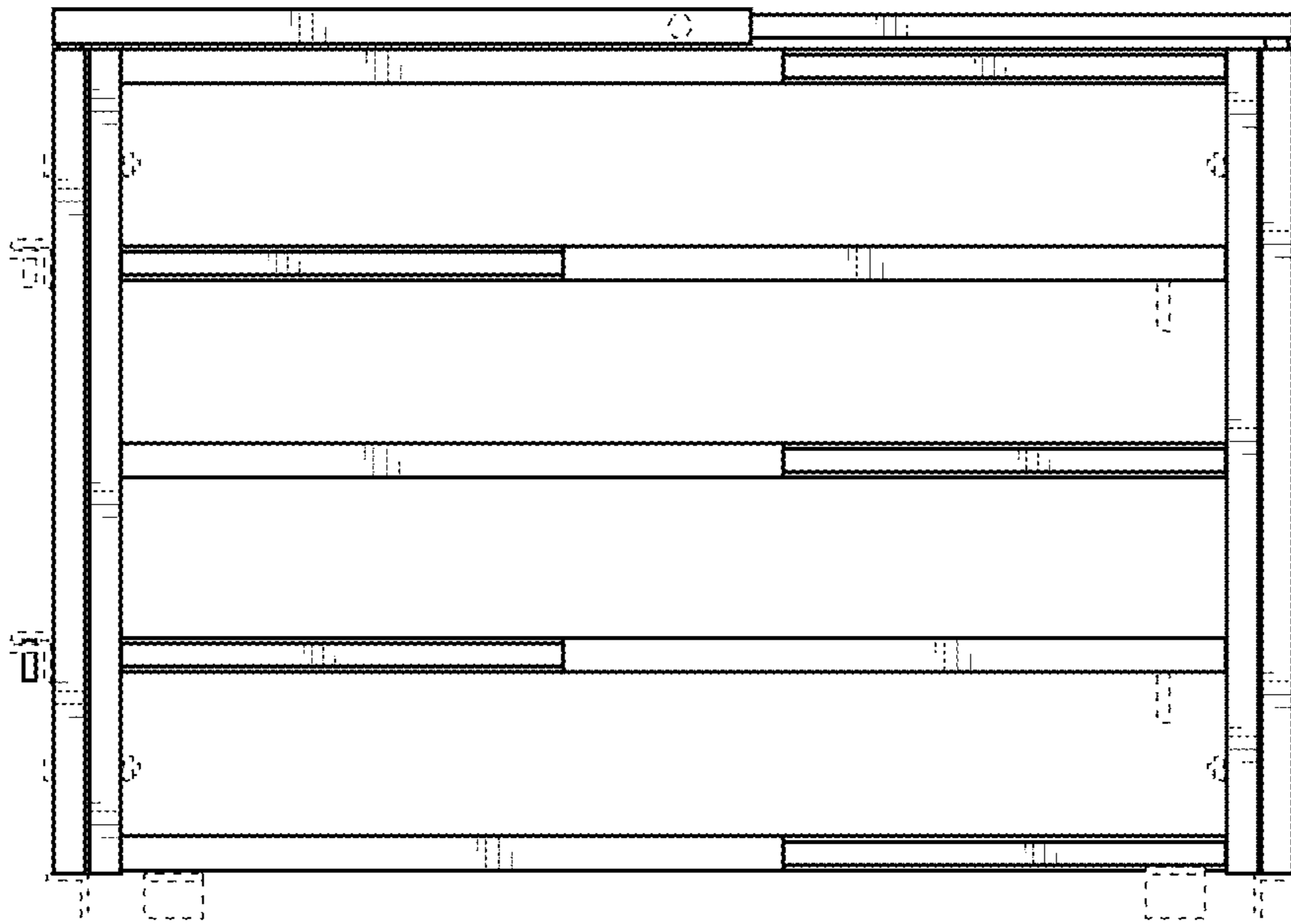

**FIG. 5**

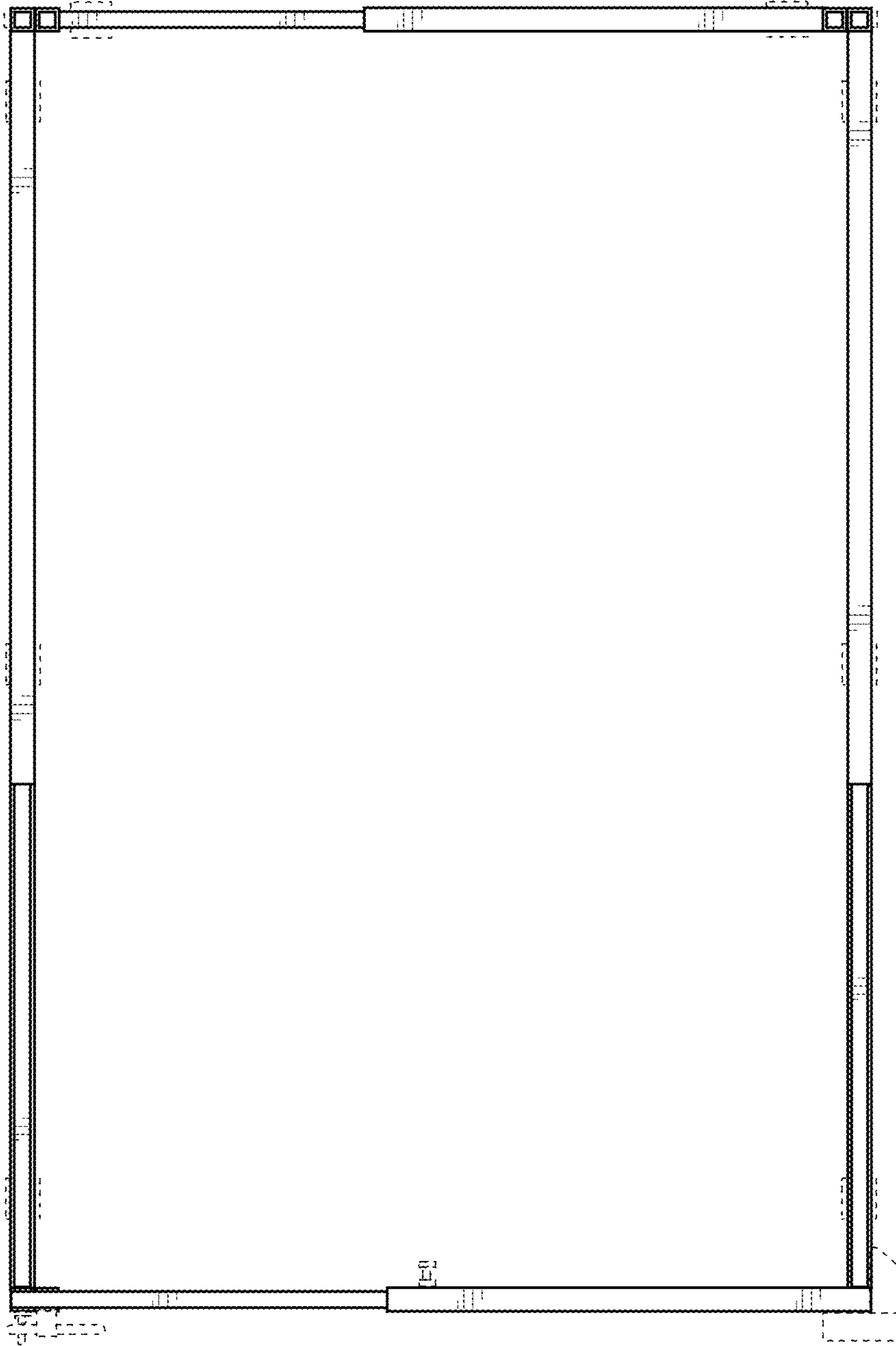

**FIG. 6**

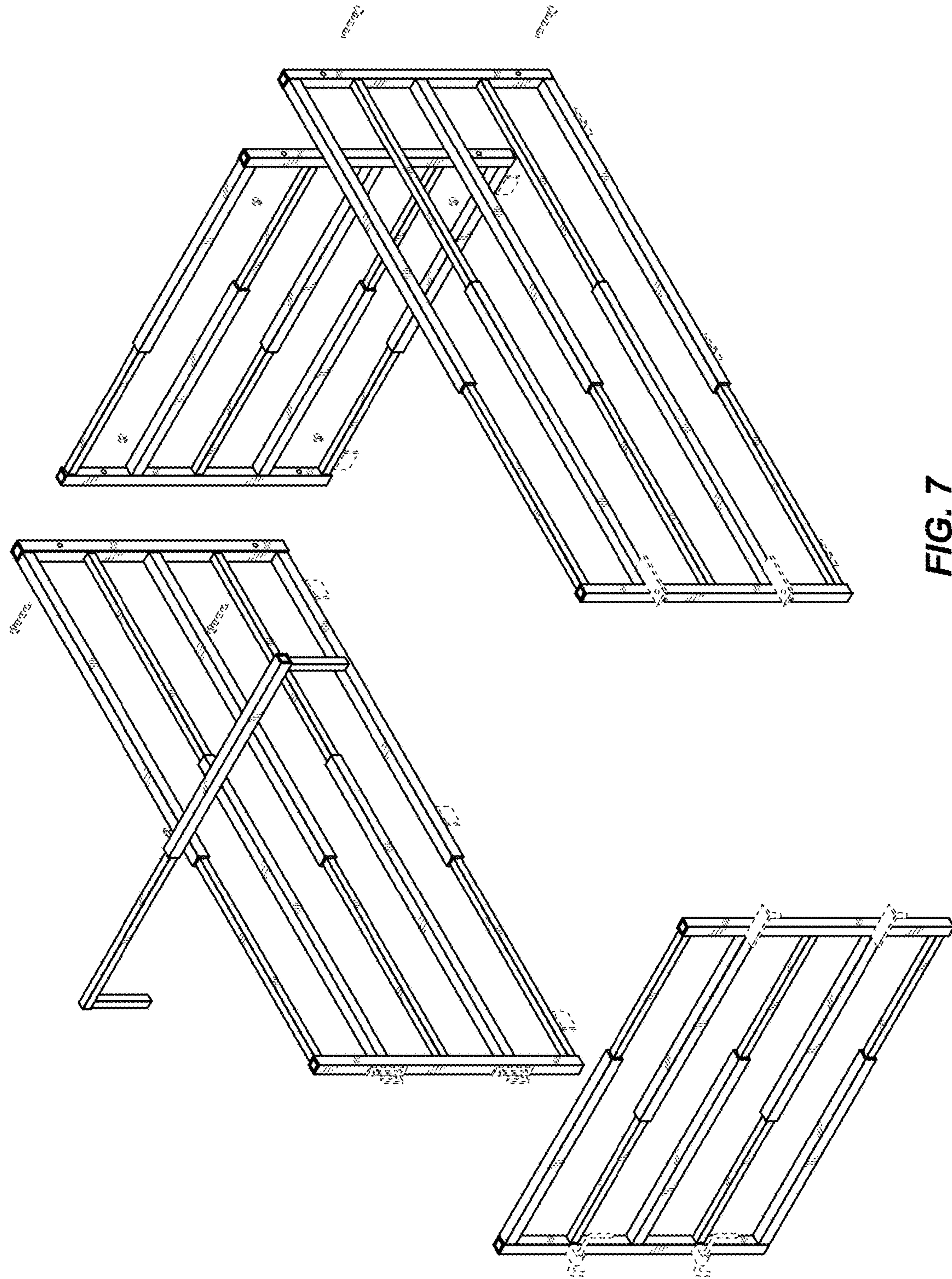

FIG. 7