



US00D813768S

(12) **United States Design Patent**
Serotta et al.

(10) **Patent No.:** **US D813,768 S**

(45) **Date of Patent:** **** Mar. 27, 2018**

(54) **BICYCLE REAR FENDER**

OTHER PUBLICATIONS

(71) Applicant: **Motivate International Inc.**, Brooklyn, NY (US)

Smooove SAS, Intelligent bike share equipment, <<http://www.smooovebikeshare.com/technology.html>>, accessed from the Internet on May 16, 2017.

(Continued)

(72) Inventors: **Benjamin Serotta**, Saratoga Springs, NY (US); **Evan Christian Solida**, Weaverville, NC (US)

Primary Examiner — Darlington Ly

(74) *Attorney, Agent, or Firm* — Jones Robb, PLLC

(57) **CLAIM**

The ornamental design for a bicycle rear fender, as shown and described.

(73) Assignee: **Motivate International Inc.**, Brooklyn, NY (US)

DESCRIPTION

(**) Term: **15 Years**

(21) Appl. No.: **29/552,346**

FIG. 1 is a top, rear, and right side perspective view of a bicycle rear fender showing our new design.

FIG. 2 is rear elevation view thereof.

FIG. 3 is a front elevation view thereof.

FIG. 4 is a left side elevation view thereof.

FIG. 5 is a right side elevation view thereof.

FIG. 6 is a top plan view thereof.

FIG. 7 is a bottom plan view thereof.

FIG. 8 is a bottom, front, and right side perspective view thereof.

FIG. 9 is a top, rear, and right side perspective view thereof as installed on an exemplary bicycle for use, for example, with a bike share system.

FIG. 10 is a right side elevation view thereof as installed on an exemplary bicycle for use, for example, with a bike share system.

FIG. 11 is a front, top, and right side perspective view thereof.

FIG. 12 is a bottom, left side perspective view thereof; and, FIG. 13 is a bottom, right side perspective view thereof.

The broken lines showing the bicycle in FIGS. 9 and 10 are provided for the purposes of illustrating environmental structure; whereas all other broken lines show portions of the bicycle rear fender. The broken line showings of the aforementioned bicycle and portions of the bicycle rear fender do not form part of the claimed design.

(22) Filed: **Jan. 21, 2016**

(51) **LOC (11) Cl.** **12-16**

(52) **U.S. Cl.**
USPC **D12/186**

(58) **Field of Classification Search**
USPC D12/110, 111, 114, 126, 184–186
CPC B62J 15/00; B62J 23/00
See application file for complete search history.

(56) **References Cited**

U.S. PATENT DOCUMENTS

D112,889 S *	1/1939	Vassos	D12/111
D158,652 S *	5/1950	Dailey	D12/184
4,813,583 A *	3/1989	Carpenter	B62J 17/00
				224/421
7,322,592 B2 *	1/2008	Francis	B62K 19/00
				280/152.2
D612,781 S *	3/2010	Harrell, Jr.	D12/186
D634,249 S *	3/2011	Dallaire	D12/186
D730,781 S *	6/2015	Arbour	D12/111

1 Claim, 13 Drawing Sheets

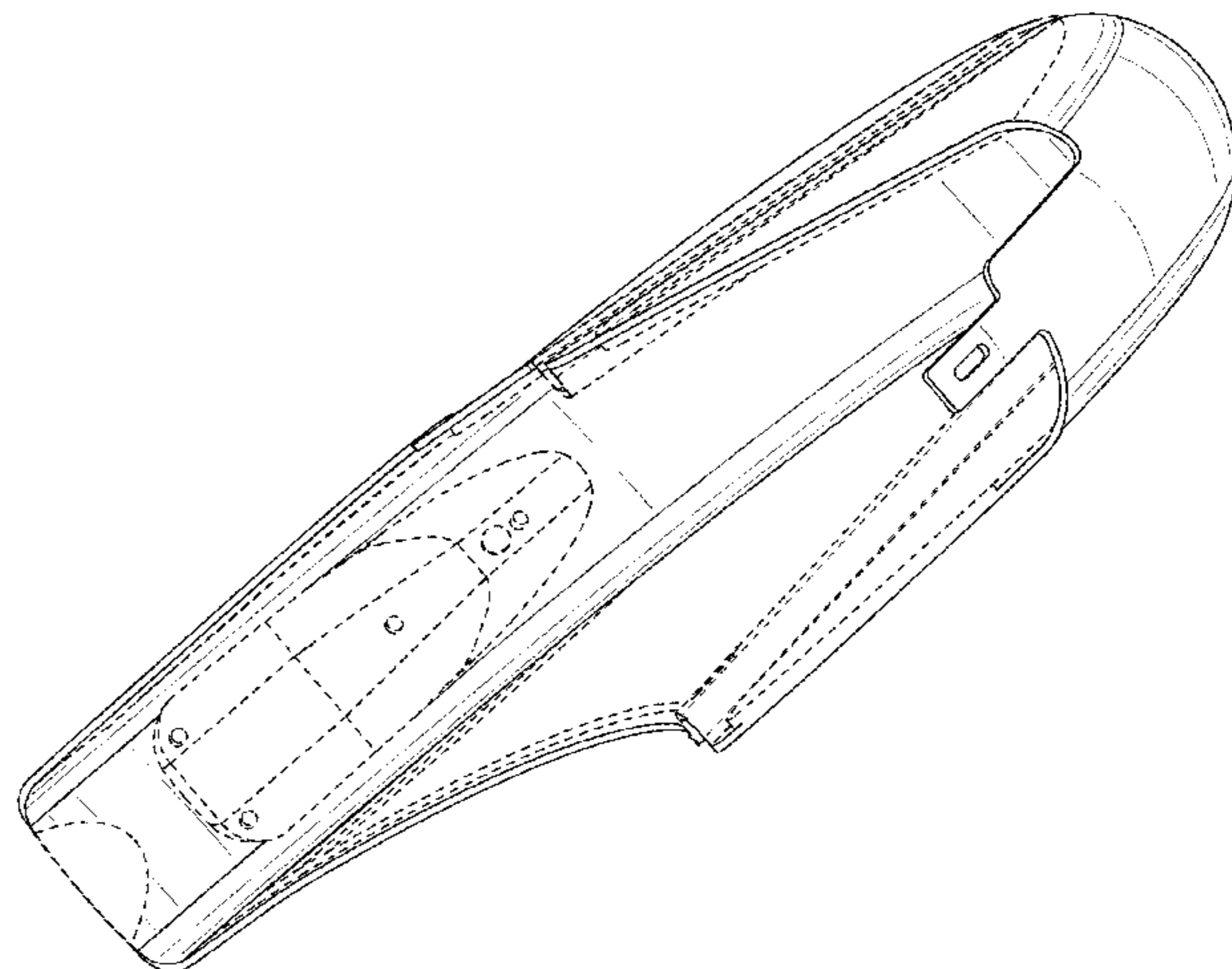
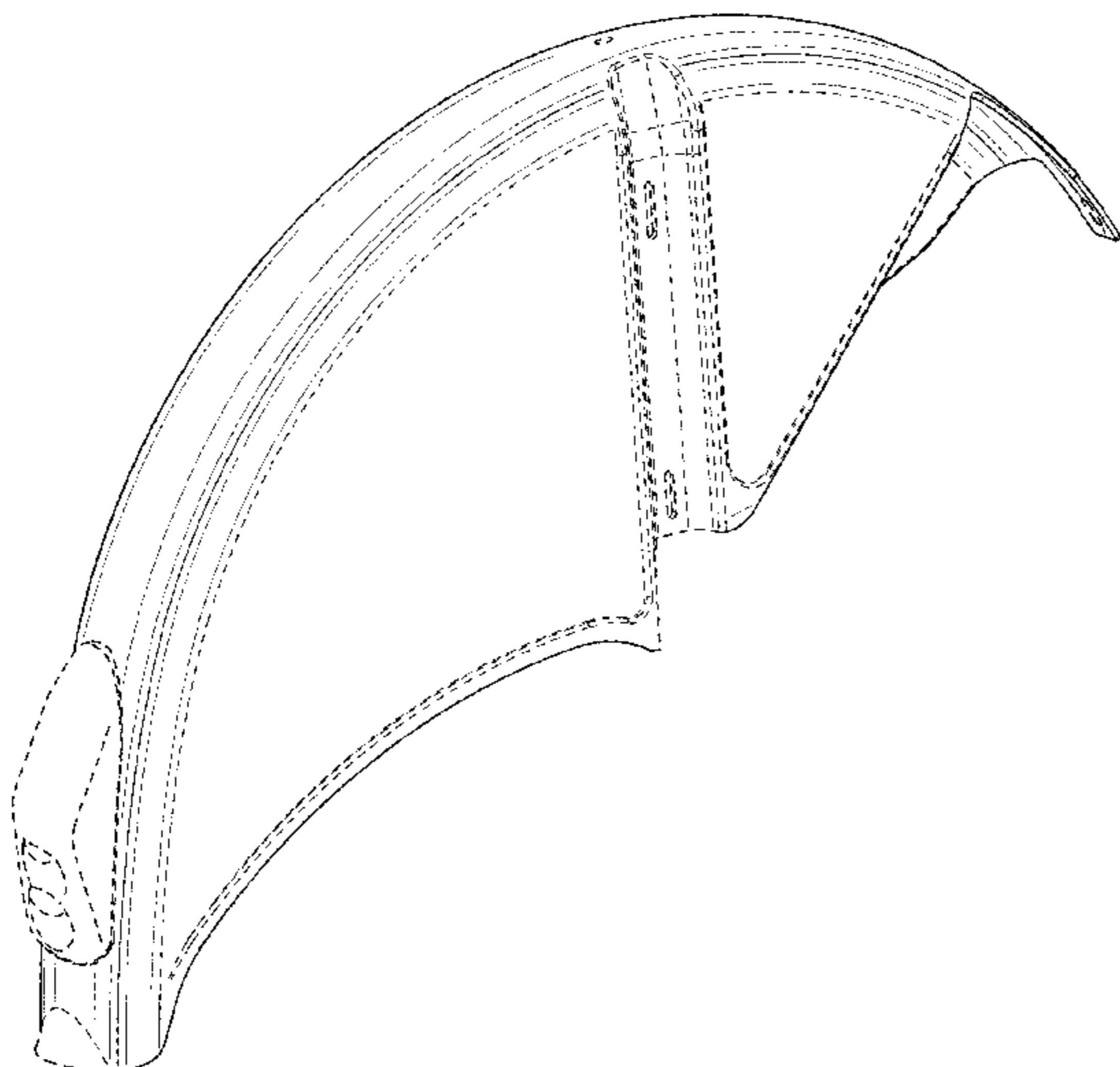

(56)

References Cited

OTHER PUBLICATIONS

Bikeshare Hawaii, Our Year in Review, Dec. 20, 2016, <<http://www.bikesharehawaii.org/newsletters/2016/12/20/our-year-in-review>>, accessed from the Internet on May 16, 2017.

Channel NewsAsia, National bicycle-sharing scheme scrapped, Singapore, dated Mar. 24, 2017, <<http://www.channelnewsasia.com/news/singapore/national-bicycle-sharing-scheme-scrapped-8592934>>, accessed from the Internet on May 16, 2017.

Motivate, Motivate bike development, Update for Capital Bikeshare, presented to City of Washington, D.C. on Jan. 21, 2015 (only p. 3).

* cited by examiner

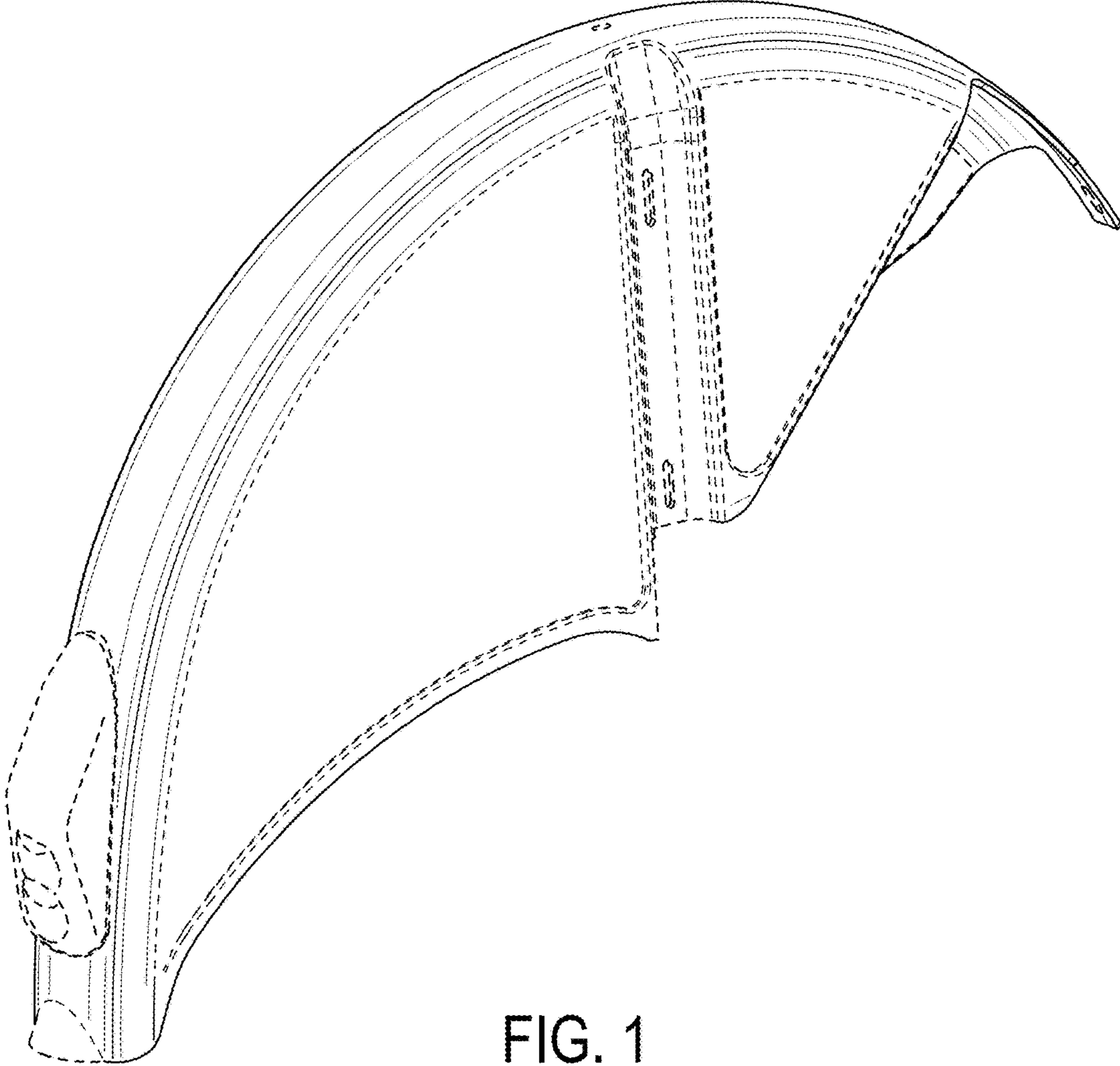

FIG. 1

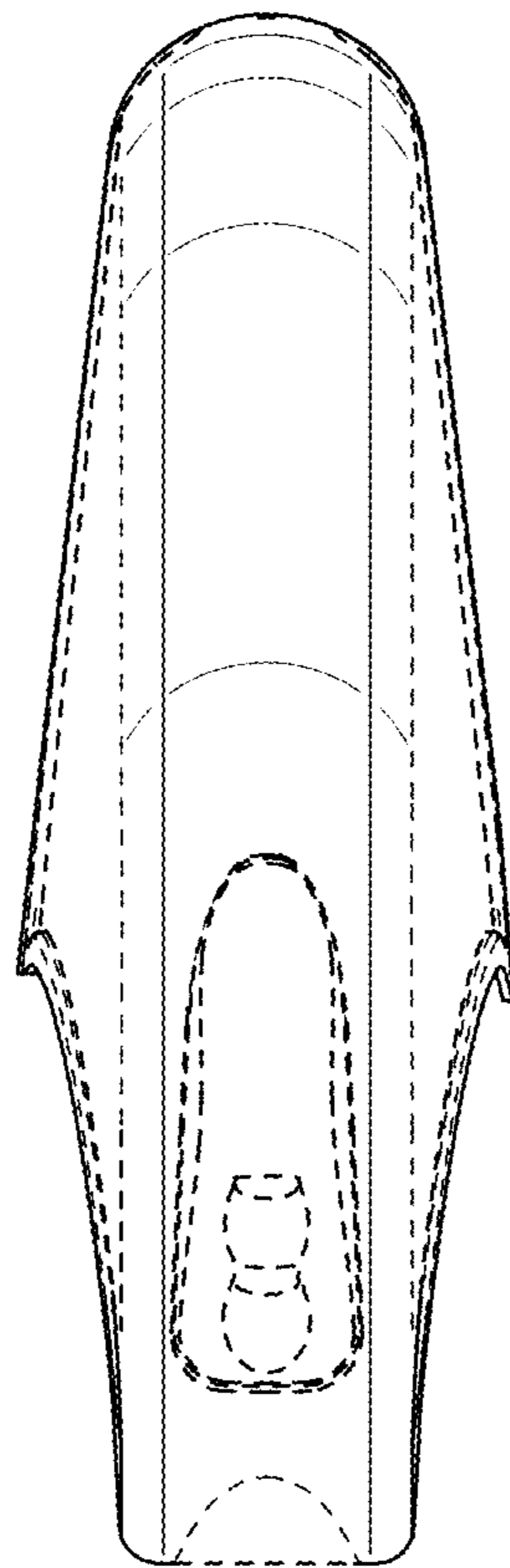

FIG. 2

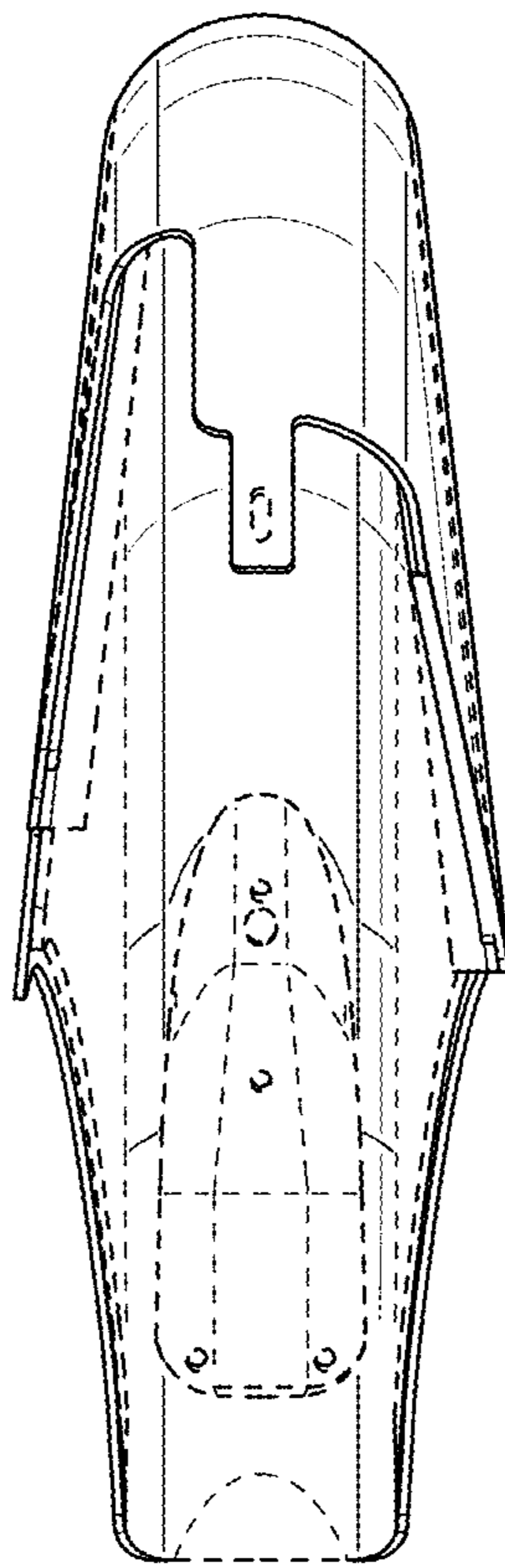

FIG. 3

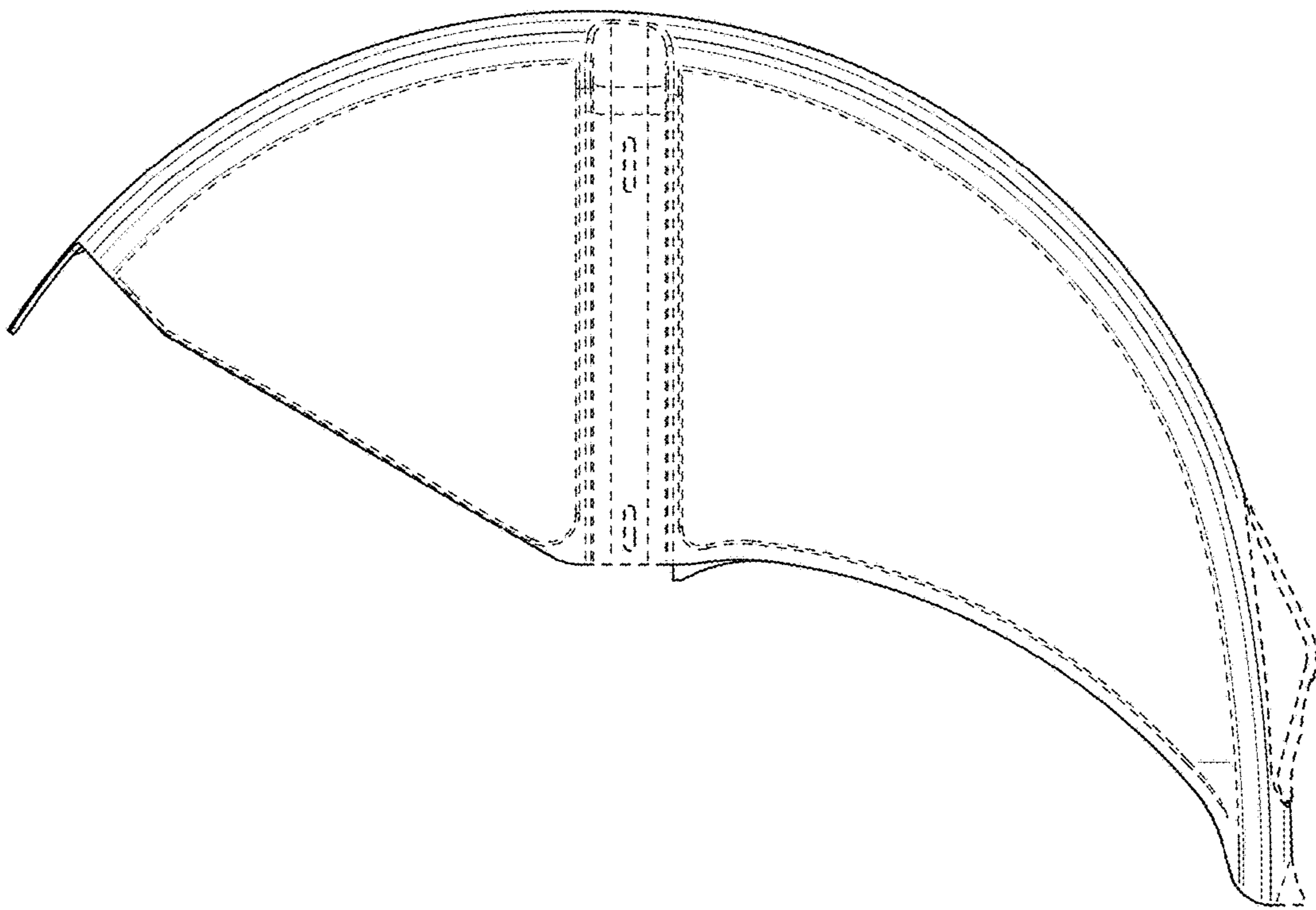

FIG. 4

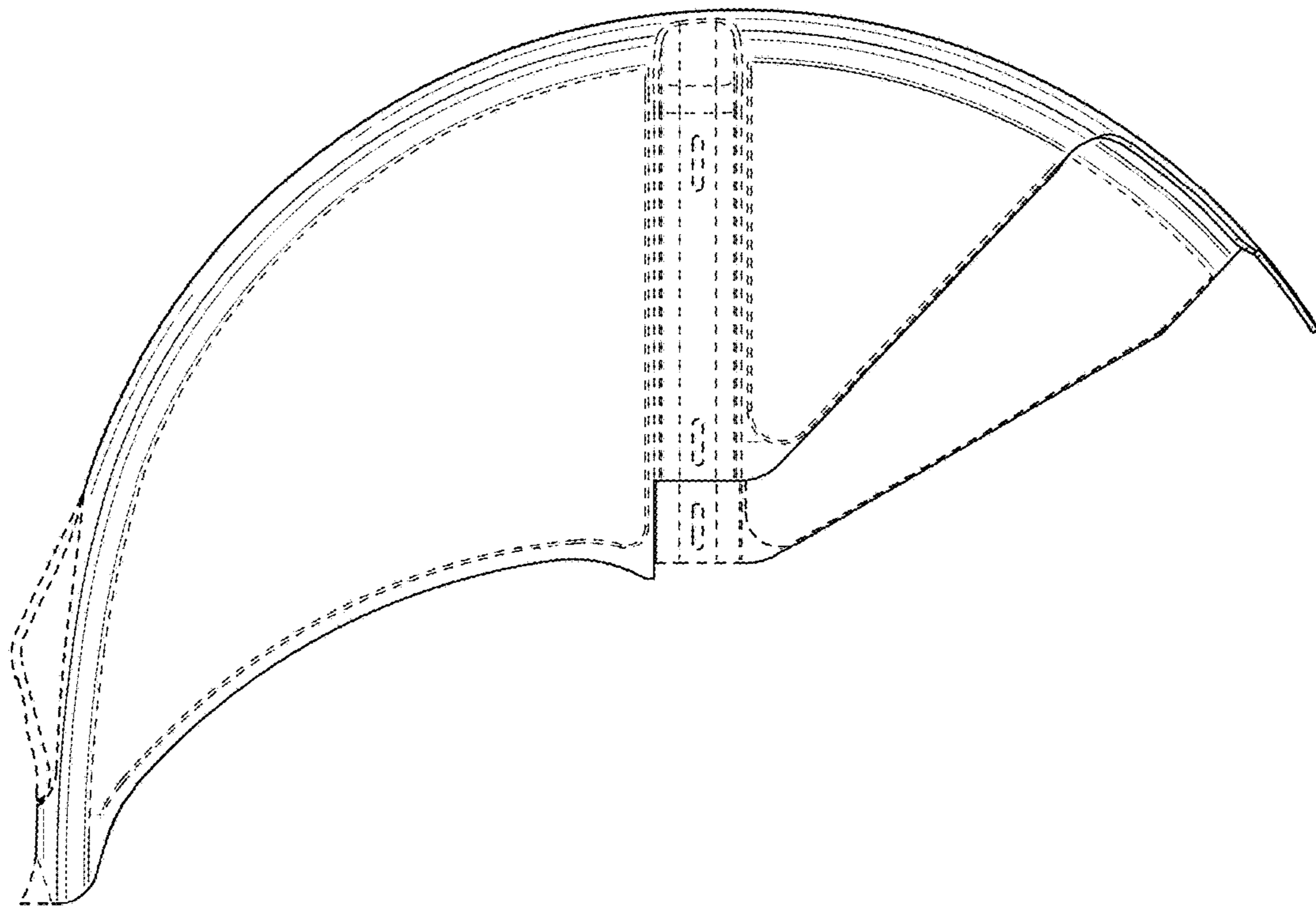

FIG. 5

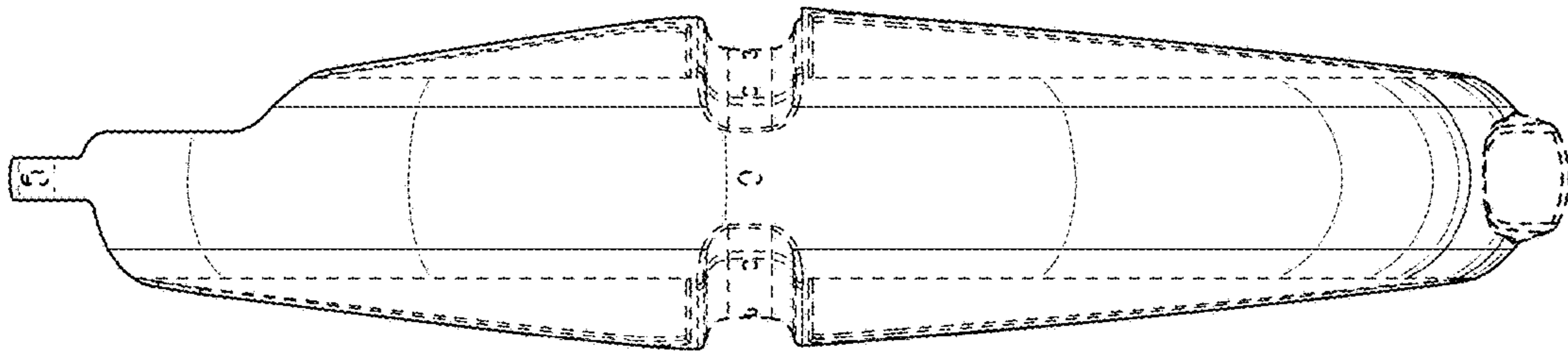

FIG. 6

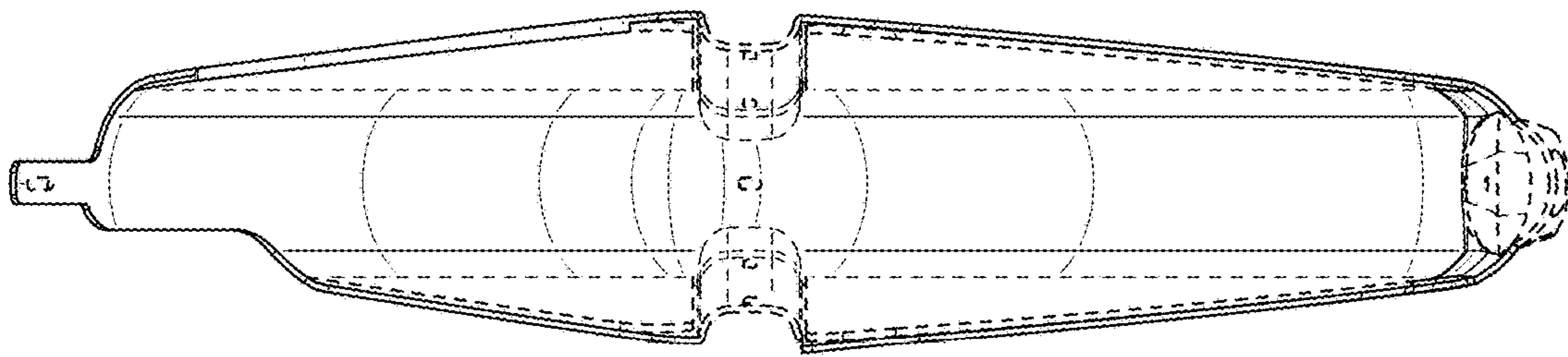

FIG. 7

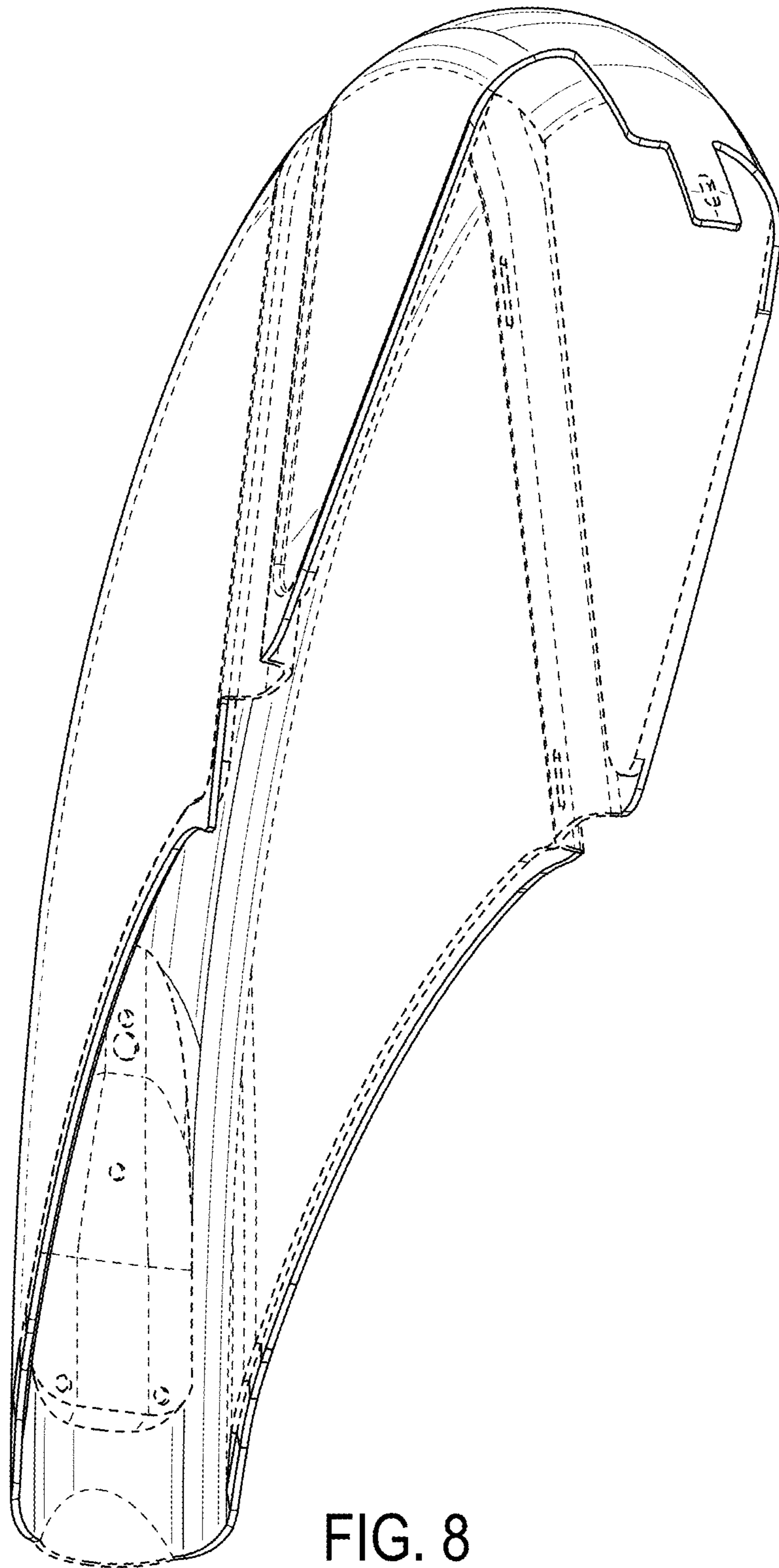

FIG. 8

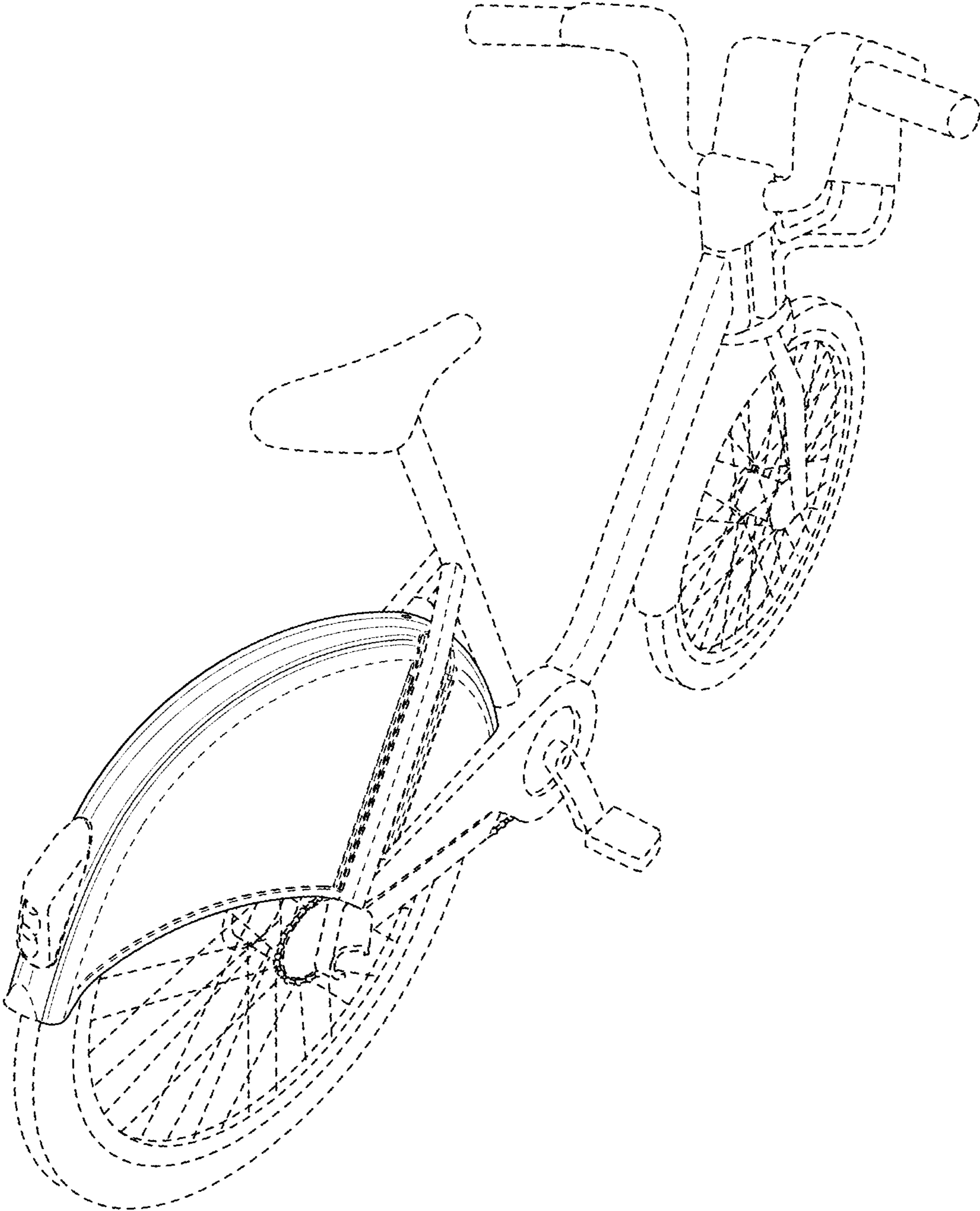

FIG. 9

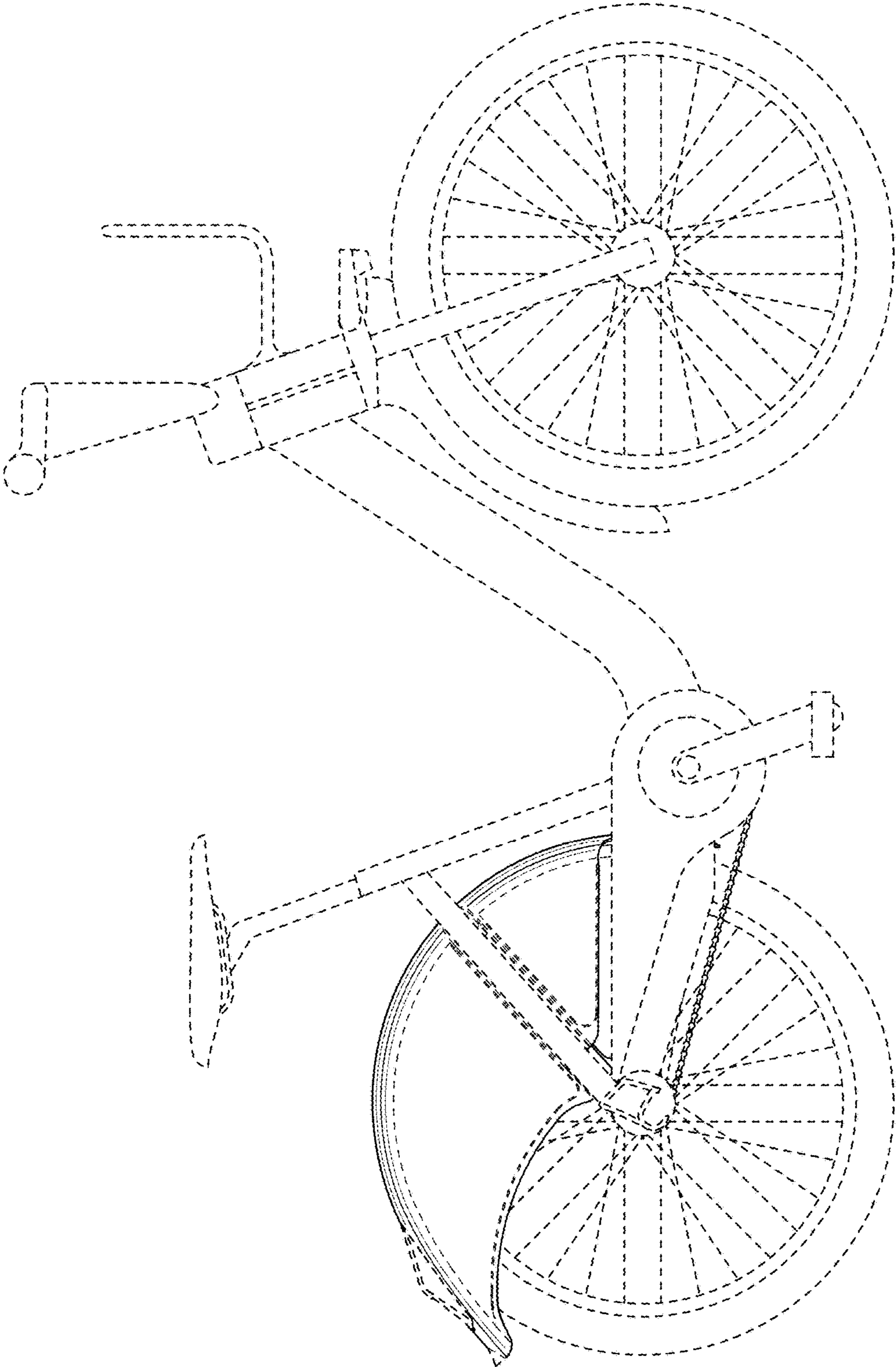

FIG. 10

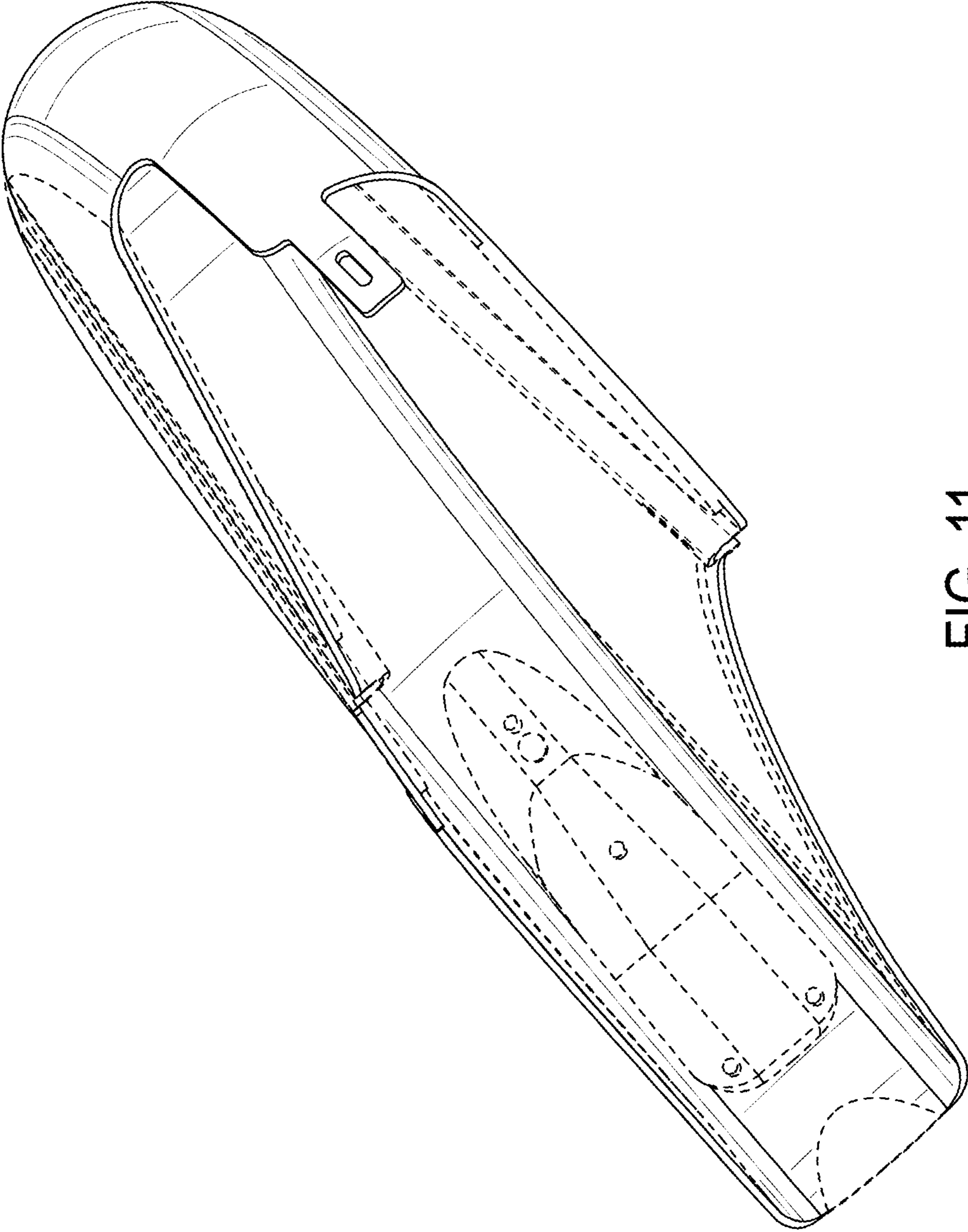

FIG. 11

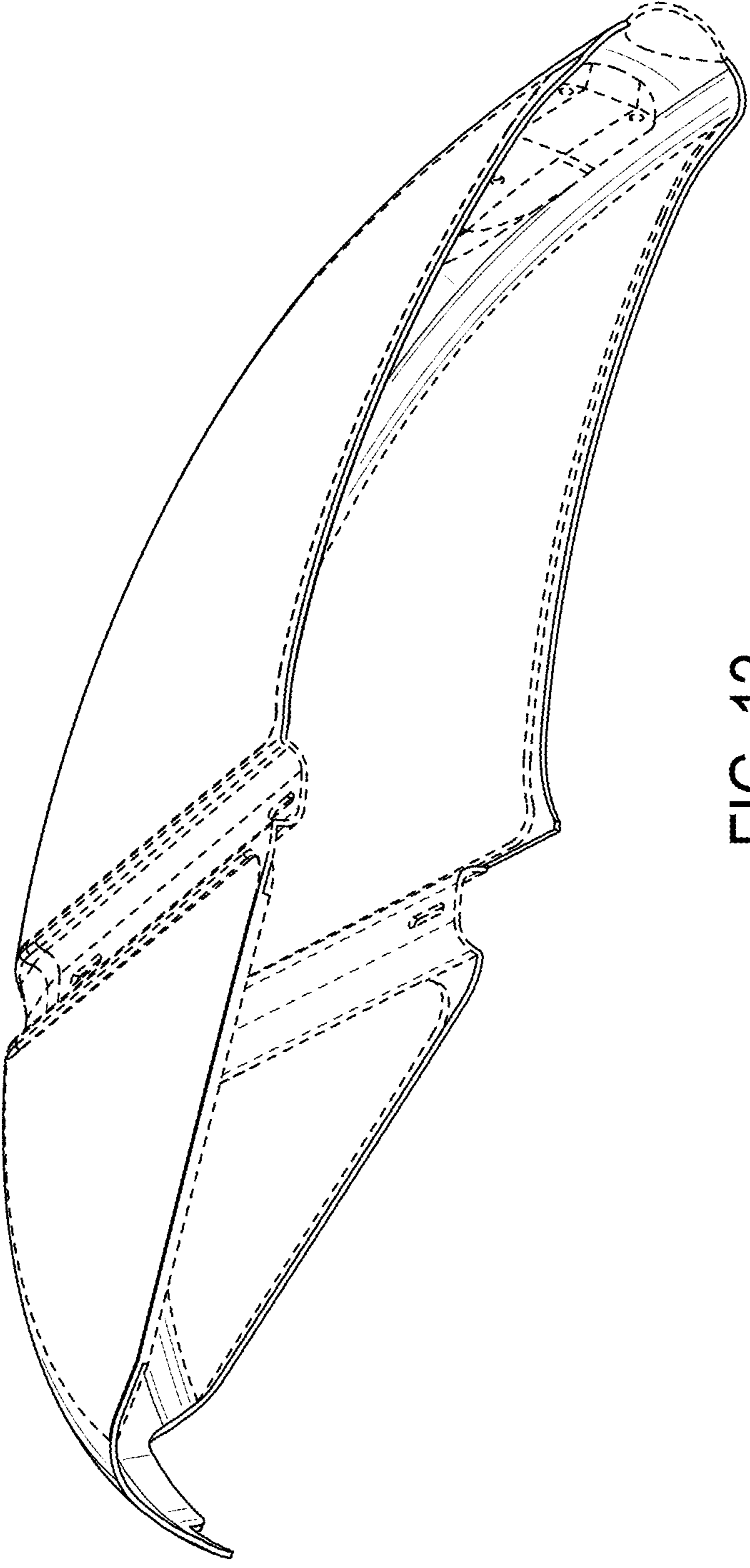

FIG. 12

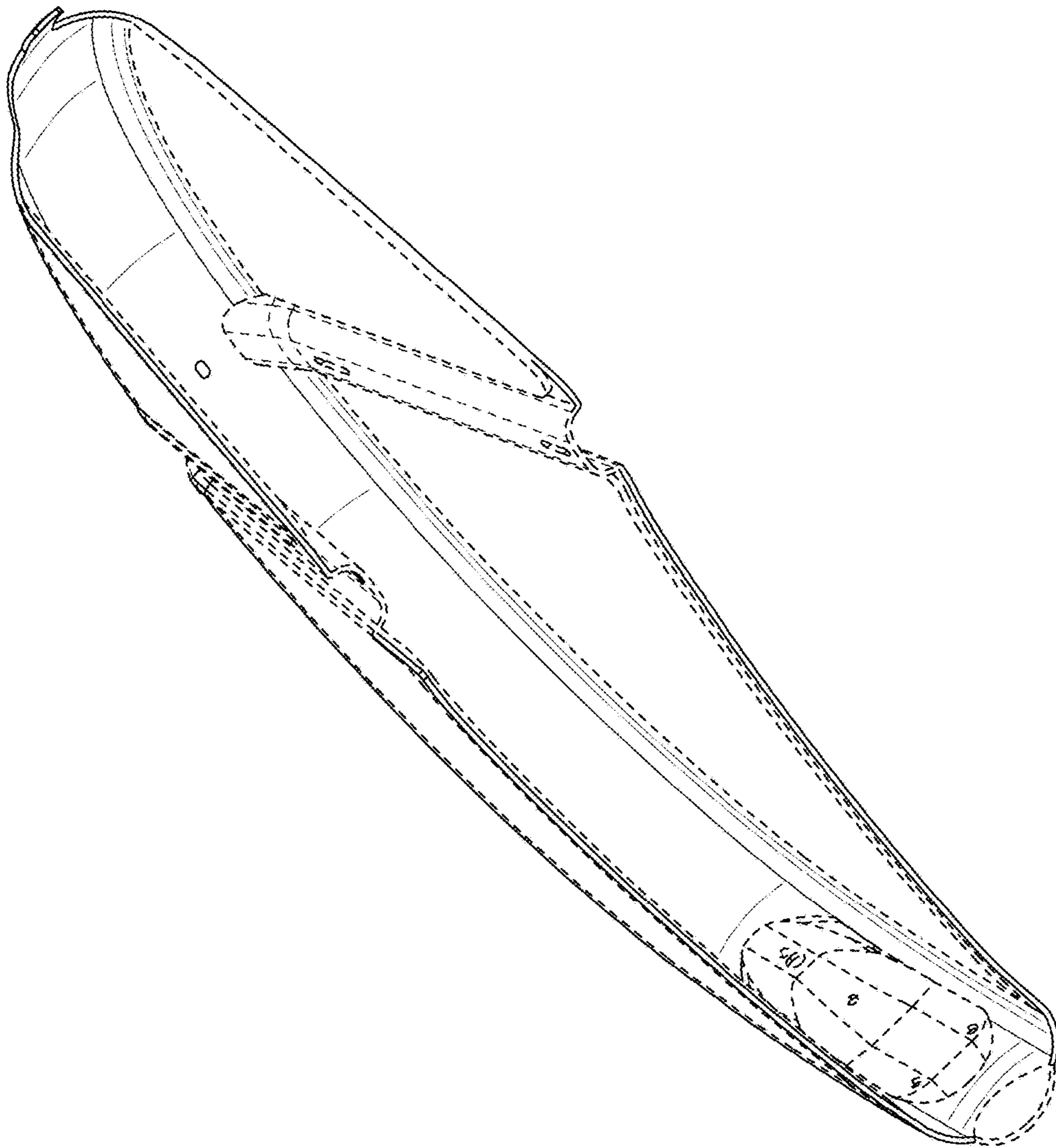

FIG. 13