



US00D813641S

(12) **United States Design Patent**  
**Osanai**

(10) **Patent No.:** **US D813,641 S**  
(45) **Date of Patent:** **\*\* Mar. 27, 2018**

(54) **CONTROL KNOB FOR A SHOCK ABSORBER**  
(71) Applicant: **SHOWA CORPORATION**, Saitama (JP)  
(72) Inventor: **Akihito Osanai**, Shizuoka (JP)  
(73) Assignee: **SHOWA CORPORATION**, Saitama (JP)

D472,947 S \* 4/2003 Wu ..... D21/694  
D572,998 S \* 7/2008 Crain ..... D8/305  
7,963,003 B1 \* 6/2011 Keene ..... F24C 15/086  
16/441  
2005/0283049 A1 \* 12/2005 Seki ..... A61B 1/0011  
600/147  
2009/0065316 A1 \* 3/2009 Chen ..... B62K 25/08  
188/322.14  
2009/0173925 A1 \* 7/2009 Turner ..... B66F 3/24  
254/93 H

(\*\*) Term: **15 Years**  
(21) Appl. No.: **29/598,706**  
(22) Filed: **Mar. 28, 2017**

(Continued)  
*Primary Examiner* — T. Chase Nelson  
*Assistant Examiner* — Ania Aman  
(74) *Attorney, Agent, or Firm* — Rankin, Hill & Clark LLP

(30) **Foreign Application Priority Data**

Sep. 30, 2016 (JP) ..... 2016-021210

(51) **LOC (11) Cl.** ..... **08-06**  
(52) **U.S. Cl.**  
USPC ..... **D8/310**

(58) **Field of Classification Search**  
USPC ..... D12/118, 400, 161, 159, 160, 201–213,  
D12/197, 223, 114; D8/402, 499, 300,  
D8/303, 308, 309, 310, 311, 312, 313,  
D8/314, 321, 322, 397, 394, 382, 349,  
D8/387, 388, 391, 393, 399, 307;  
D23/206; D9/453, 503; D15/5  
CPC ..... B62K 2025/041; B62K 2025/045; B62K  
2025/048; B62K 2025/042; B62K  
2025/044; B62K 2025/047; G05G 9/02;  
G05G 9/00; F16F 1/121; F16F 13/02;  
F16F 13/04; F16F 13/101; F16F 15/0275;  
F16F 15/1202

See application file for complete search history.

(56) **References Cited**

**U.S. PATENT DOCUMENTS**

D101,826 S \* 11/1936 Sinko ..... D12/179  
D451,361 S \* 12/2001 Yang ..... D8/307

(57) **CLAIM**

The ornamental design for a control knob for a shock absorber, as shown and described.

**DESCRIPTION**

FIG. 1 is a front, right side, bottom perspective view of a control knob for a shock absorber showing my new design; FIG. 2 is a rear, left side, bottom perspective view thereof; FIG. 3 is a front view thereof; FIG. 4 is a rear view thereof; FIG. 5 is a left side view thereof, a right side view being symmetrical; and, FIG. 6 is a top plan view thereof, a bottom plan view being symmetrical.

The broken lines in the Figures show portions of the control knob that form no part of the claimed design. The control knob can be for a shock absorber for a motorcycle. The control knob can be for adjusting a buffering property, a vibration suppression characteristic, and a function of a motorcycle body posture control for a motorcycle.

**1 Claim, 3 Drawing Sheets**

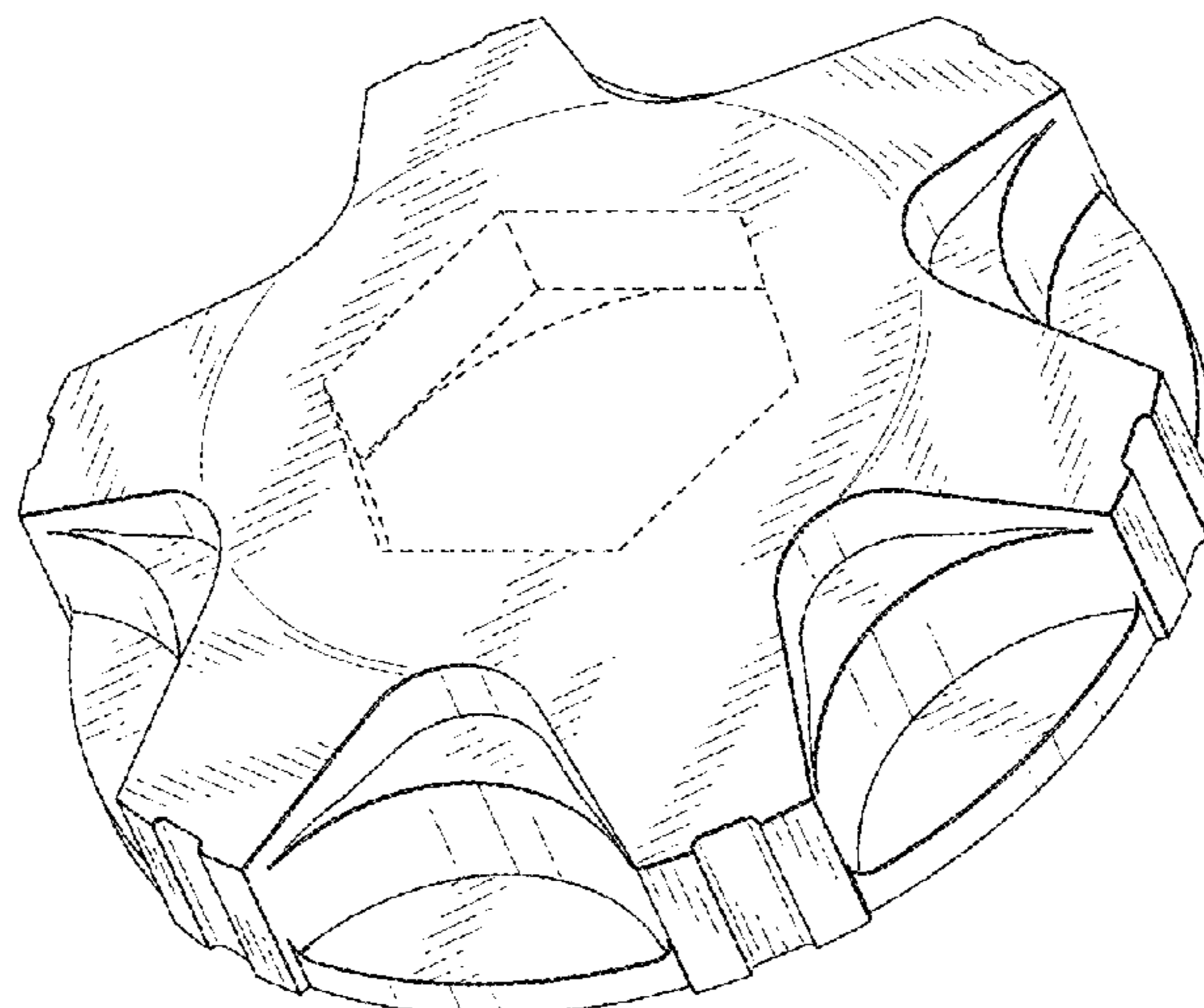

(56)

**References Cited**

U.S. PATENT DOCUMENTS

2012/0228906 A1\* 9/2012 McAndrews ..... B62J 1/08  
297/215.13  
2013/0192940 A1\* 8/2013 Furukawa ..... F16F 9/516  
188/282.1  
2016/0167730 A1\* 6/2016 Lozac'h ..... B62K 25/08  
267/286  
2016/0185177 A1\* 6/2016 Kaneko ..... F16F 9/3235  
267/221

\* cited by examiner

FIG. 1

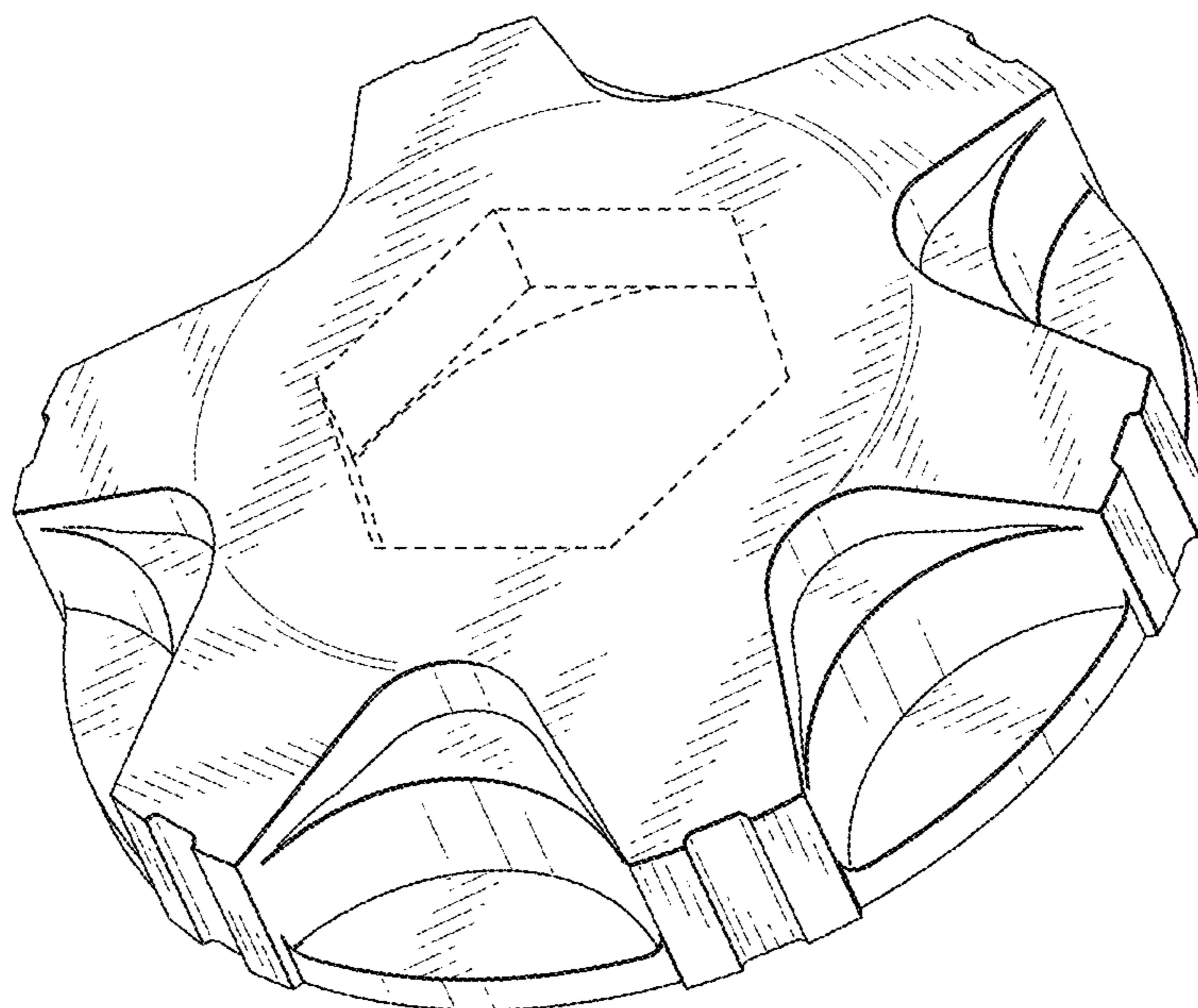

FIG. 2

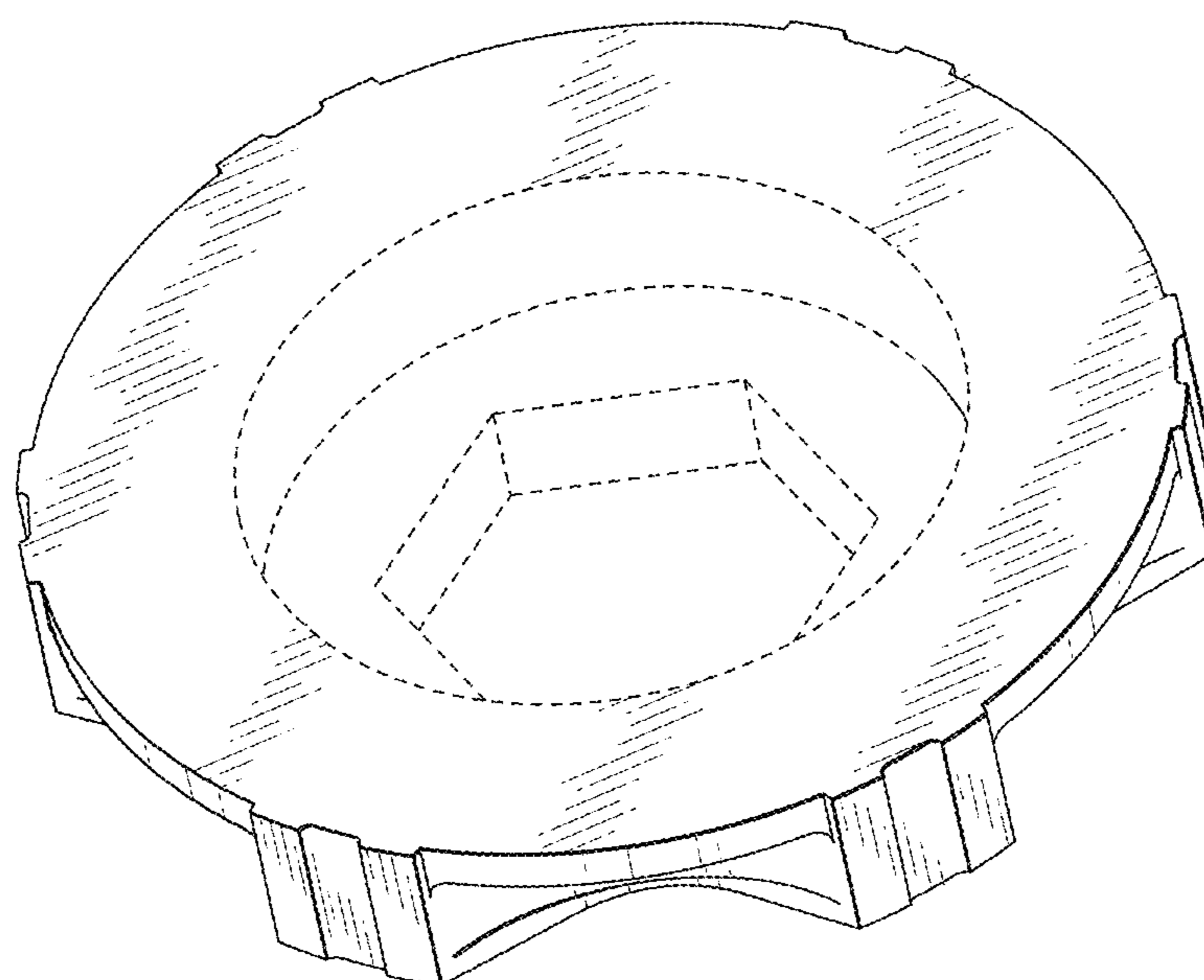

FIG. 3

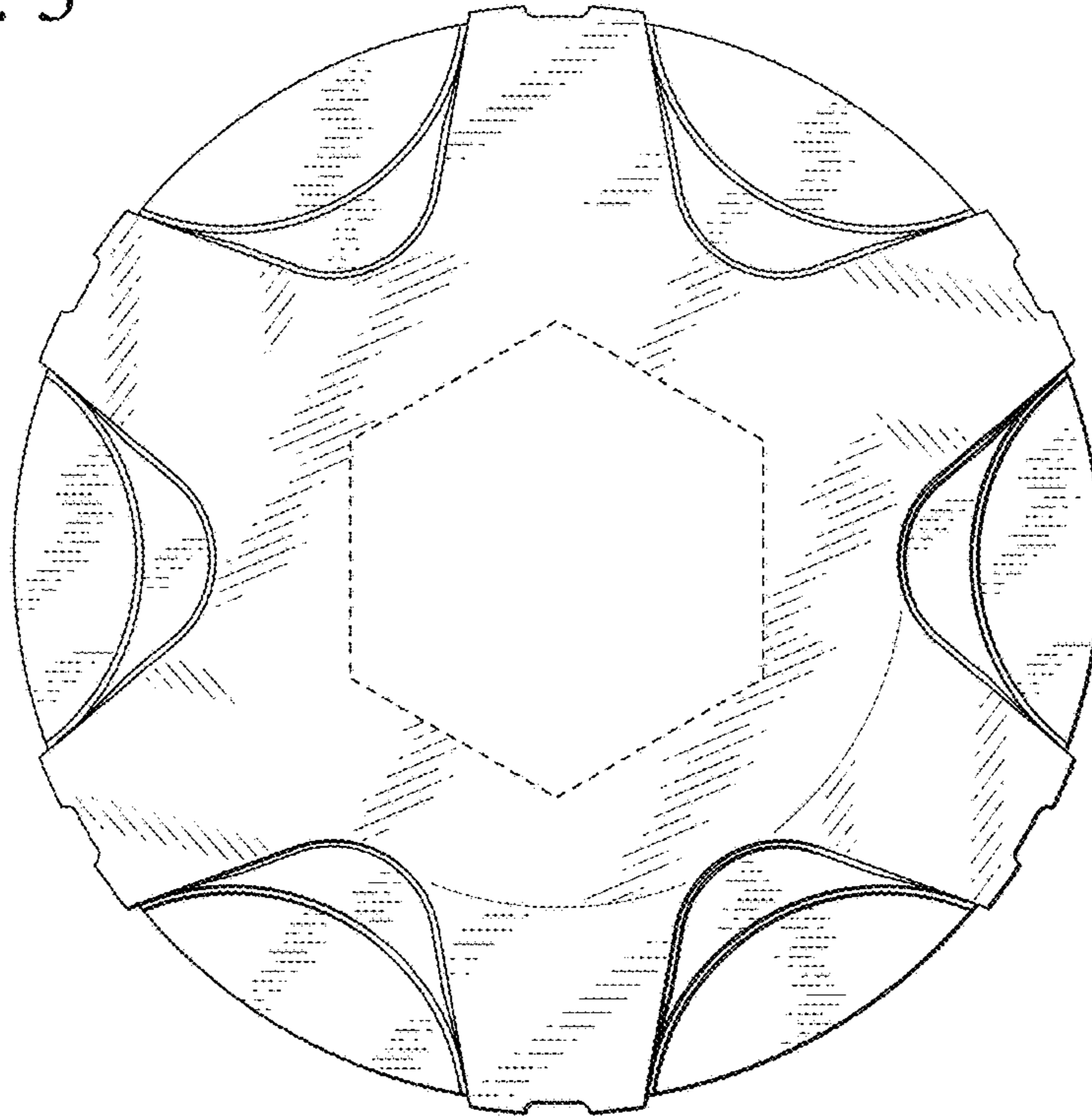

FIG. 4

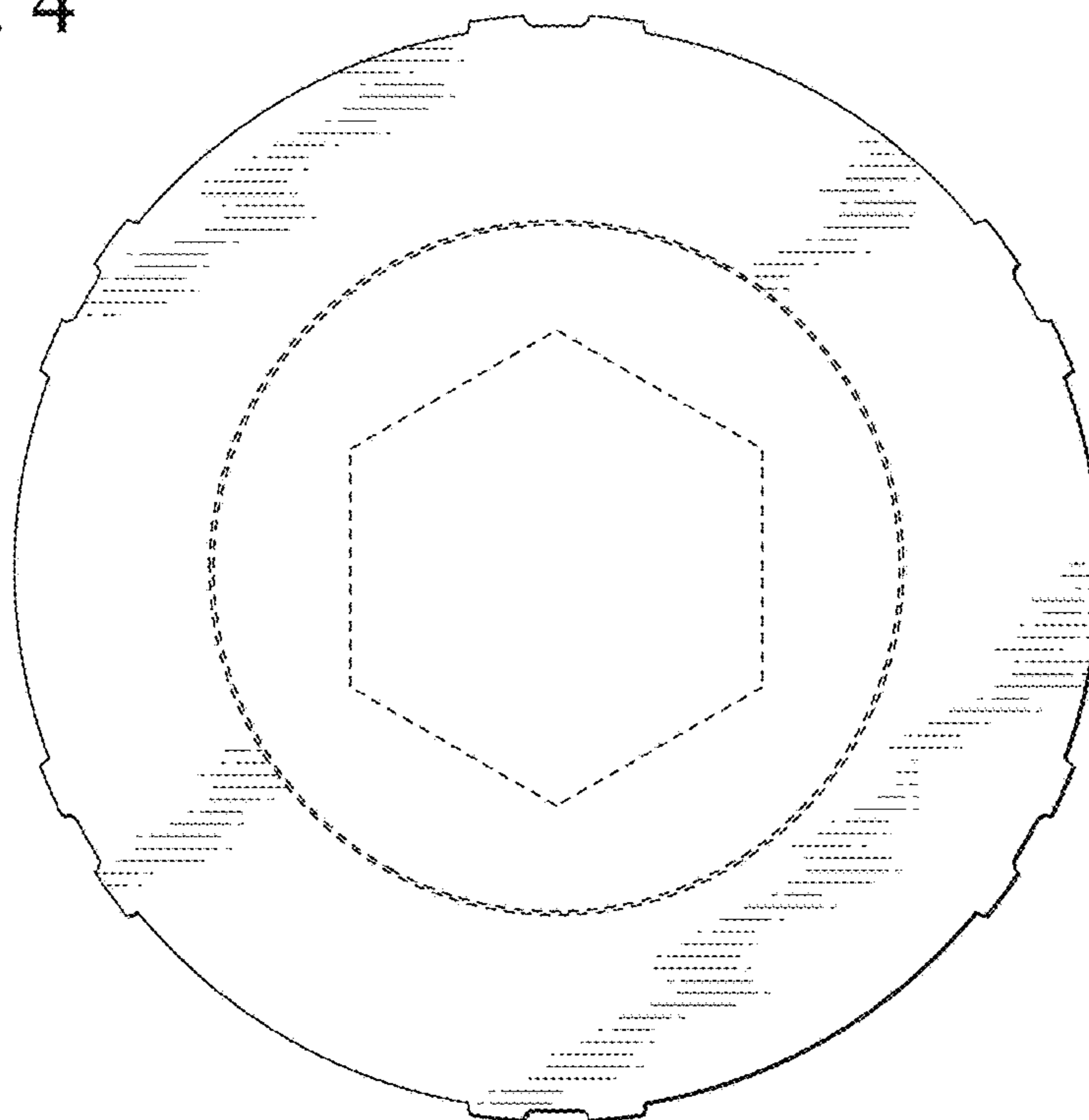



FIG. 5

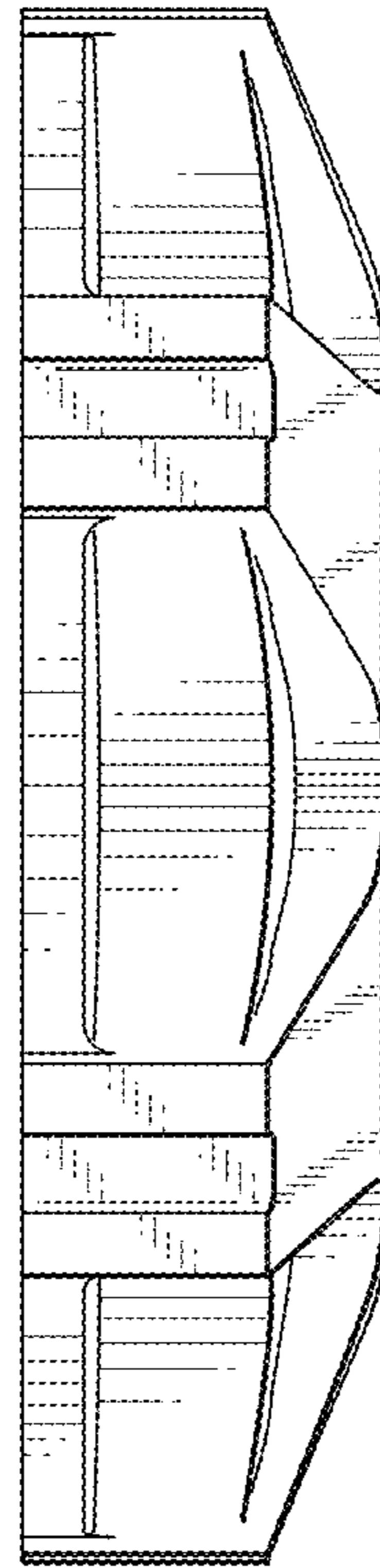

FIG. 6

