



US00D813164S

(12) **United States Design Patent**
Kaneko

(10) **Patent No.:** **US D813,164 S**

(45) **Date of Patent:** **** Mar. 20, 2018**

(54) **MOTOR FOR RAILWAY VEHICLE**
(71) Applicant: **mitsubishi electric CORPORATION**, Tokyo (JP)
(72) Inventor: **Kenta Kaneko**, Tokyo (JP)
(73) Assignee: **mitsubishi electric CORPORATION**, Tokyo (JP)

D310,816 S * 9/1990 Sawato D13/112
D332,081 S * 12/1992 Sieber D13/112
D574,325 S * 8/2008 Naghshineh D13/114
D593,943 S * 6/2009 Lannoch D13/112
D624,015 S * 9/2010 Walker D13/112
7,965,005 B2 * 6/2011 Schmidt H02K 5/06
310/71
D664,565 S * 7/2012 Sonoda D15/5
D700,575 S * 3/2014 Andersson D13/114

* cited by examiner

(**) Term: **15 Years**

Primary Examiner — Derrick Holland

(21) Appl. No.: **29/554,953**

(74) *Attorney, Agent, or Firm* — Studebaker & Brackett
PC

(22) Filed: **Feb. 17, 2016**

(30) **Foreign Application Priority Data**

Aug. 26, 2015 (JP) 2015-018667

(51) **LOC (11) Cl.** **13-01**

(52) **U.S. Cl.**
USPC **D13/112**

(58) **Field of Classification Search**
USPC D13/112, 113, 114, 122, 184, 199;
D15/1, 5; 290/36 R, 38 R, 39; 310/10,
310/20, 40 R, 40 MM, 42, 68 D, 75 R,
310/80, 83, 88, 89, 98, 109, 114
CPC H02K 5/06; H02K 5/225; H02K 11/33;
H02K 9/14; H02K 7/1025; H02K
7/20918

See application file for complete search history.

(56) **References Cited**

U.S. PATENT DOCUMENTS

D207,401 S * 4/1967 Kerr et al. D13/114
D223,495 S * 4/1972 Martin D13/112

(57) **CLAIM**

The ornamental design for a motor for railway vehicle, as shown and described.

DESCRIPTION

FIG. 1 is a front perspective view of the front, right, and top sides of a motor for railway vehicle showing our new design; FIG. 2 is a rear perspective view of the rear, left, and bottom sides; FIG. 3 is a front view thereof; FIG. 4 is a rear view thereof; FIG. 5 is a left side view thereof; FIG. 6 is a right side view thereof; FIG. 7 is a top plan view thereof; and, FIG. 8 is a bottom plan view thereof.

The broken lines shown represent unclaimed subject matter of the motor for railway vehicle and form no part of the claimed design.

1 Claim, 8 Drawing Sheets

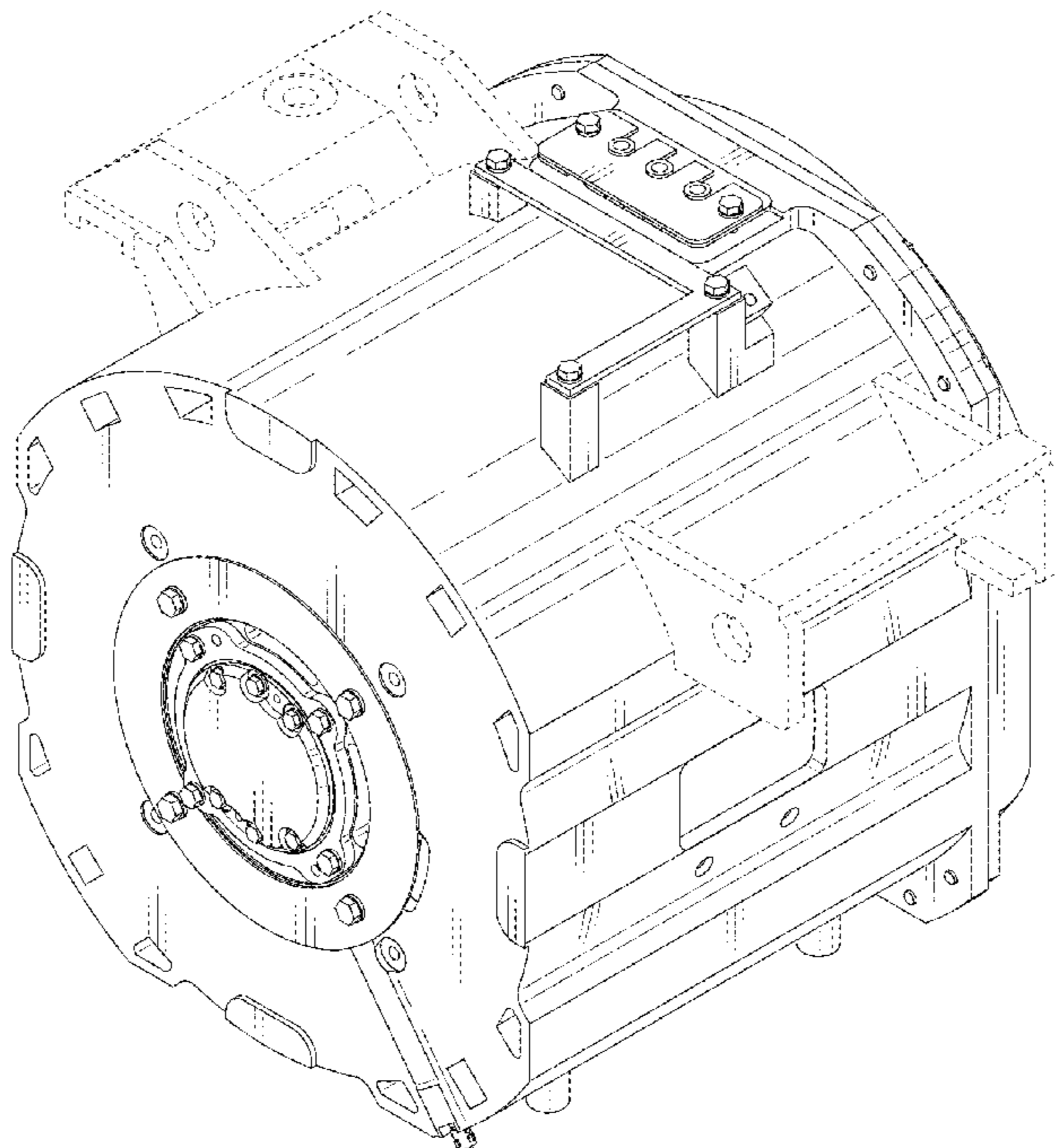

Fig. 1

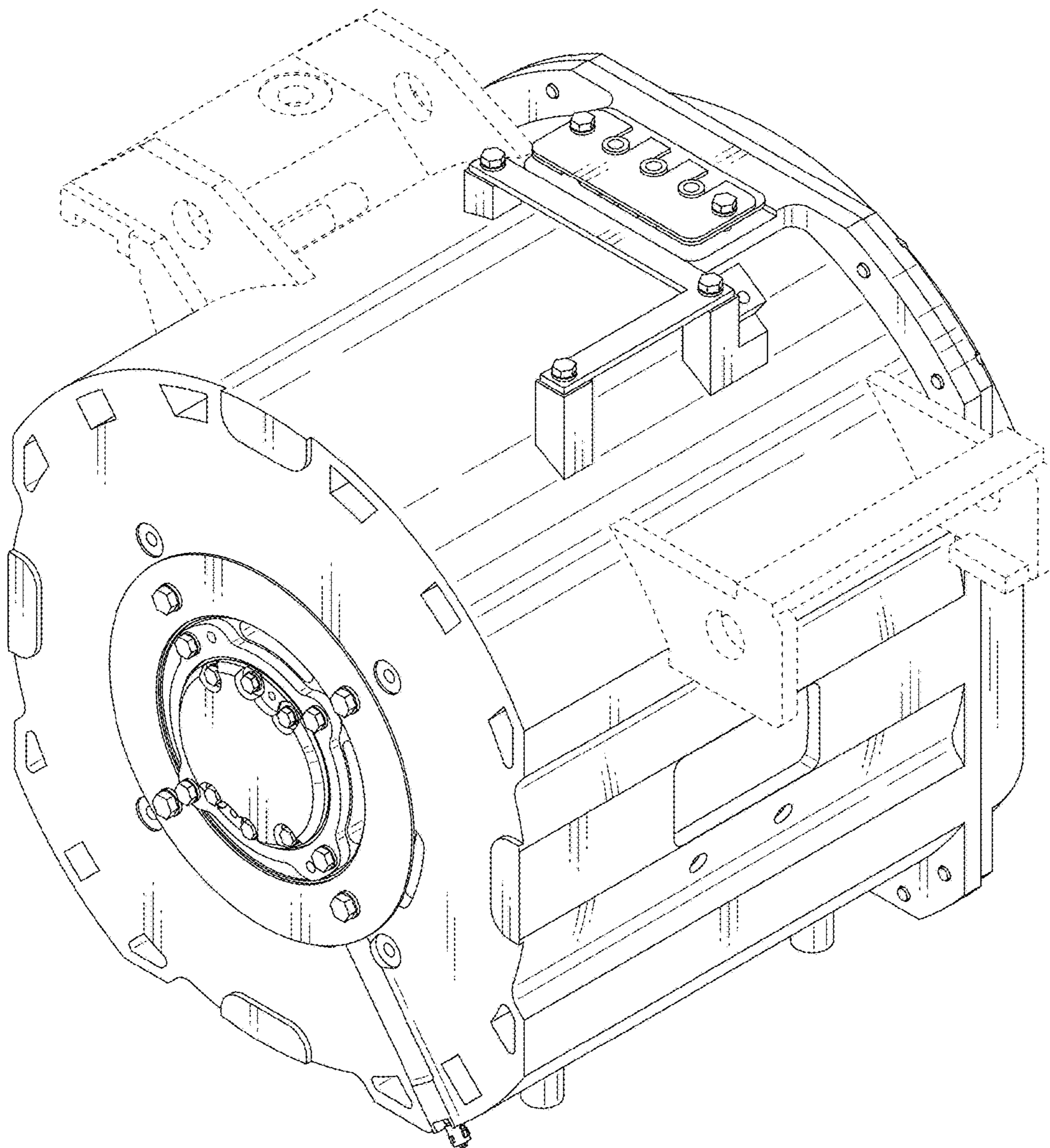

Fig. 2

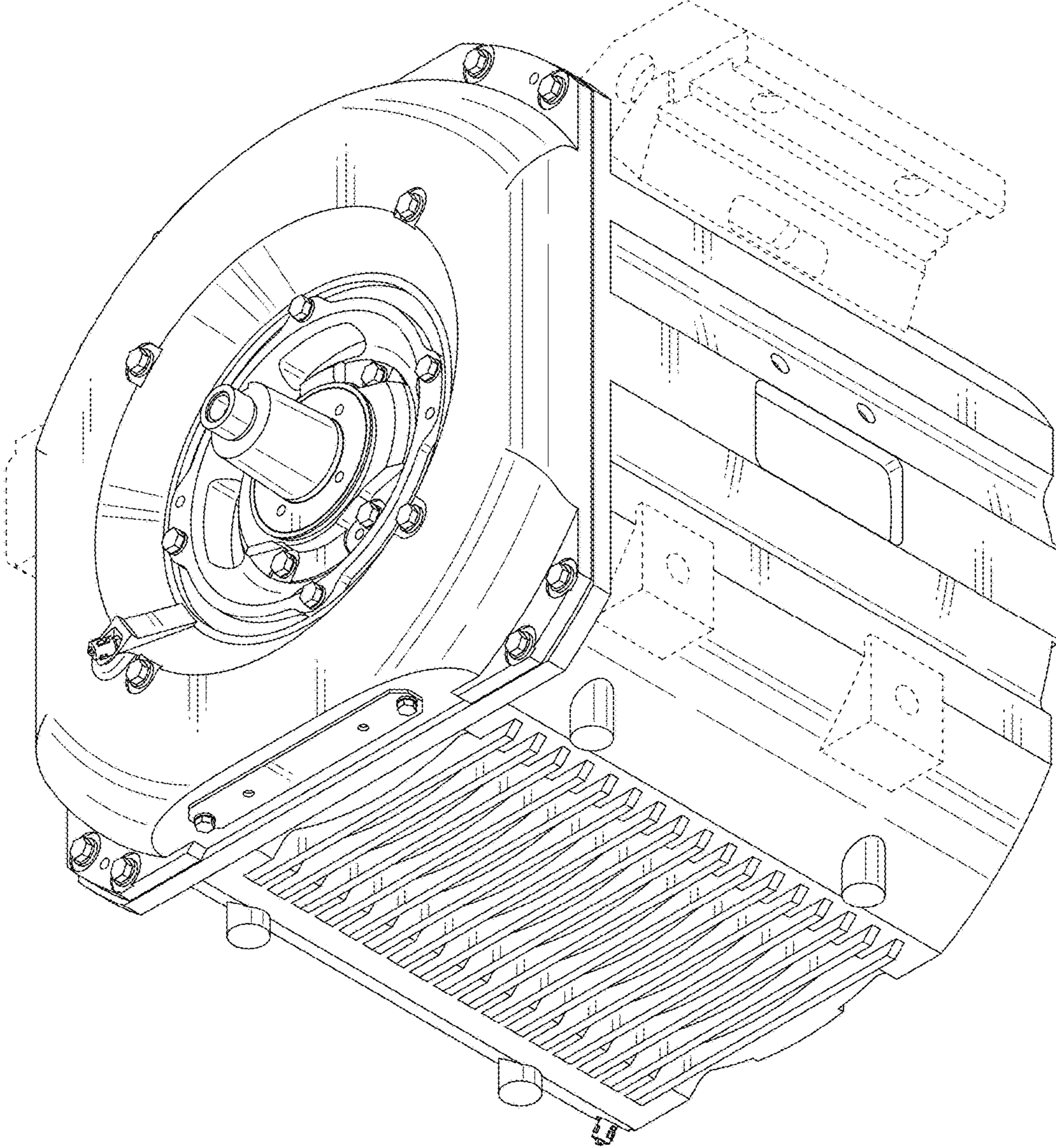

Fig. 3

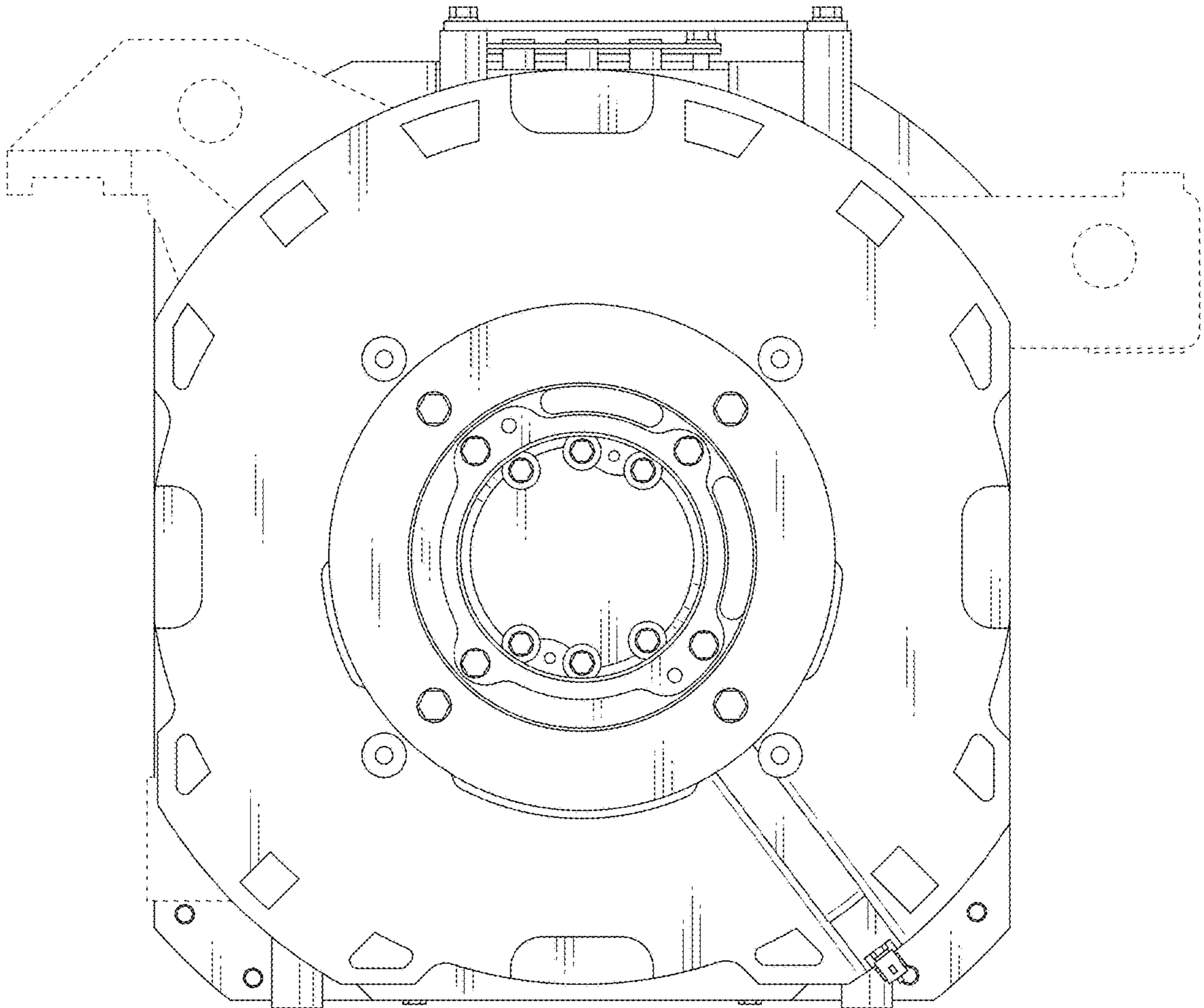

Fig. 4

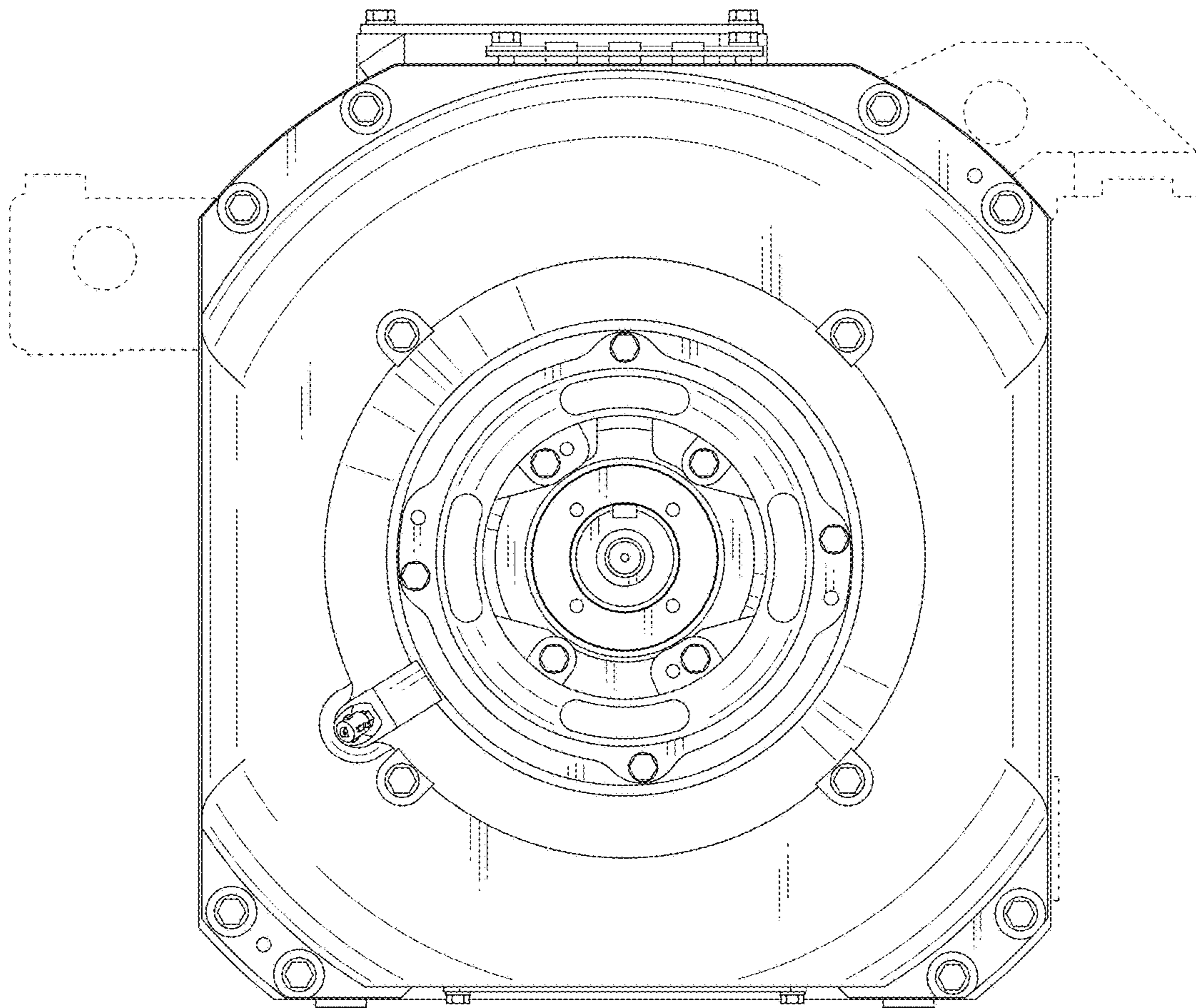

Fig. 5

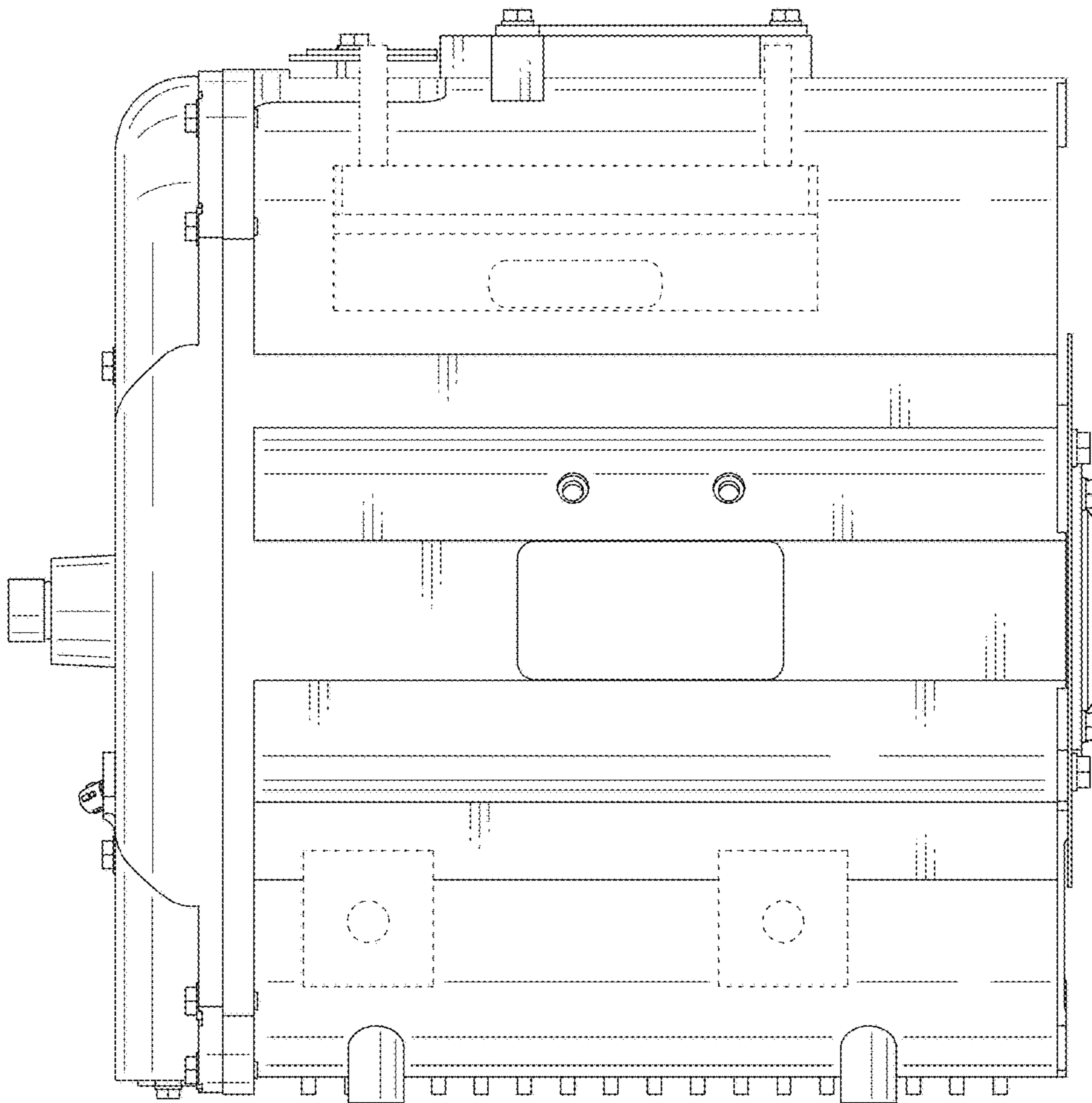

Fig. 6

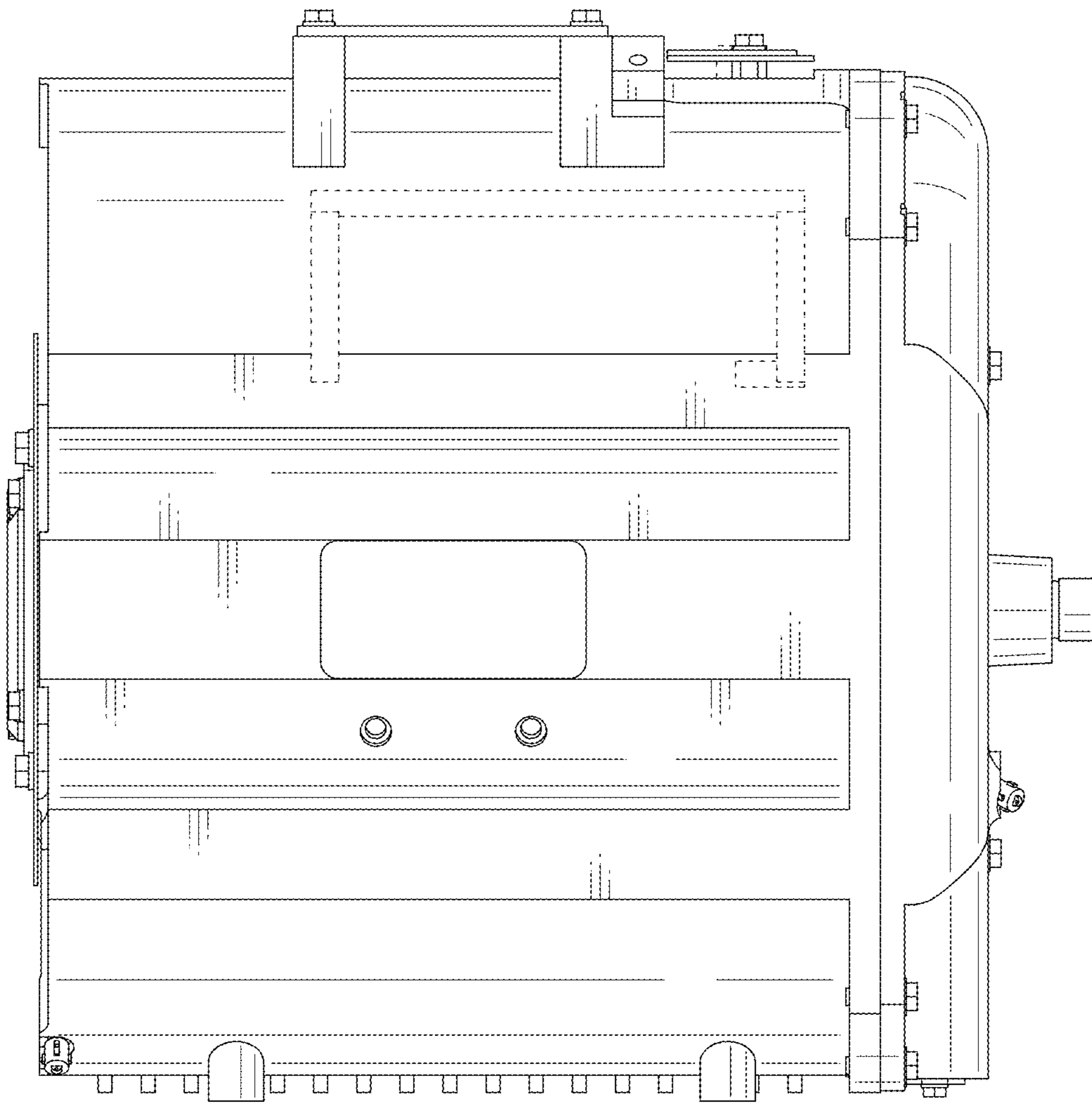

Fig. 7

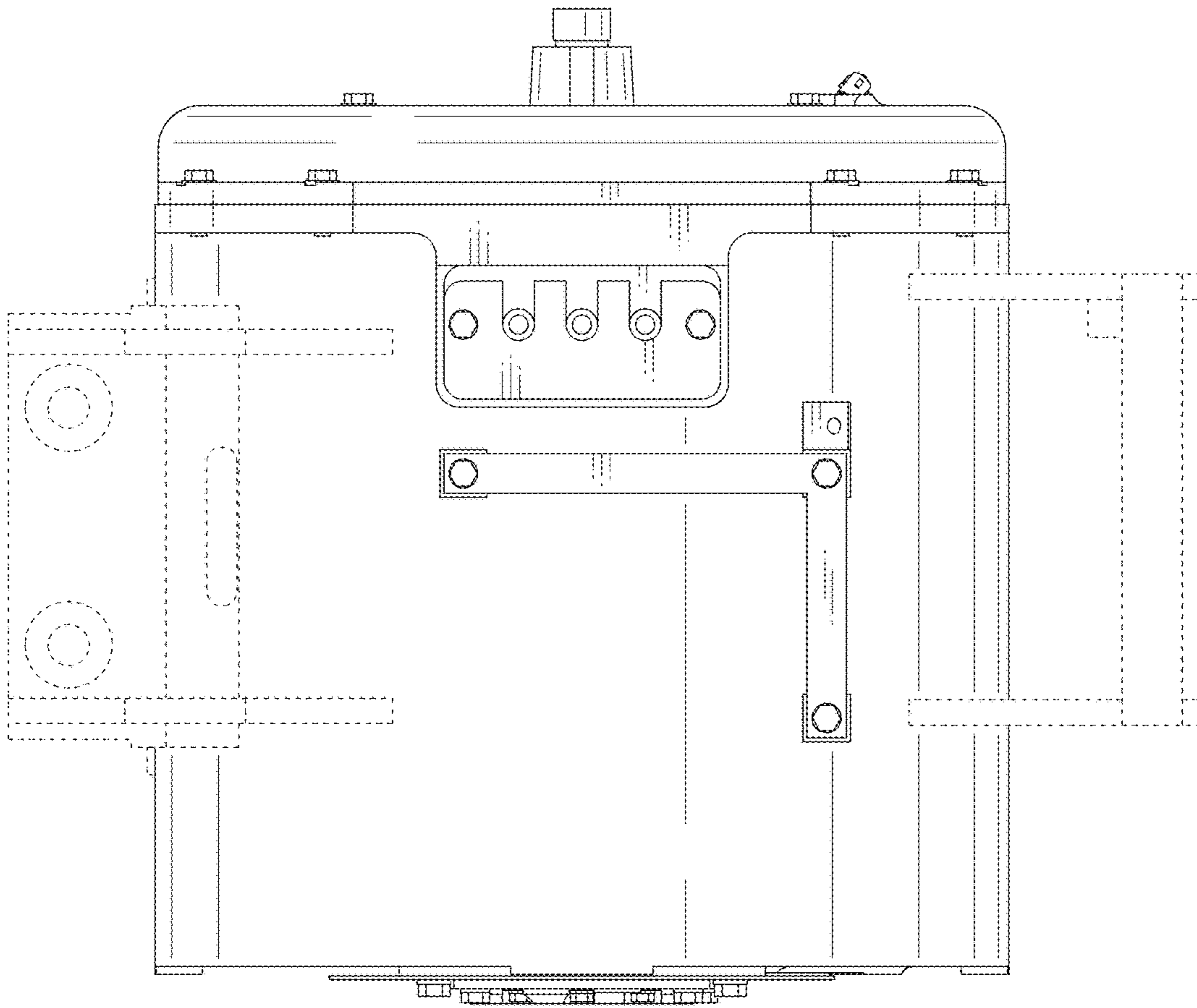

Fig. 8

