



US00D813132S

(12) **United States Design Patent** (10) **Patent No.:** **US D813,132 S**
Armigliato et al. (45) **Date of Patent:** **** Mar. 20, 2018**

(54) **VEHICLE COCKPIT**

(56) **References Cited**

(71) Applicant: **IVECO S.p.A.**, Turin (IT)

U.S. PATENT DOCUMENTS

(72) Inventors: **Marco Armigliato**, Turin (IT); **Raffaele Vergano**, Cambiano (IT); **David Melvin Wilkie**, Turin (IT); **Maddalena Varrasso**, Turin (IT)

| | | | | | | |
|-----------|----|---|---------|-----------|-------|------------|
| D666,544 | S | * | 9/2012 | Tsay | | D12/195 |
| D693,754 | S | * | 11/2013 | Balko | | D12/195 |
| 8,925,862 | B2 | * | 1/2015 | Ehlers | | B64D 11/02 |
| | | | | | | D12/195 |
| D764,991 | S | * | 8/2016 | Woodhouse | | D12/195 |
| D766,790 | S | * | 9/2016 | Sethapun | | D12/195 |
| D770,349 | S | * | 11/2016 | Ahn | | D12/195 |
| D788,000 | S | * | 5/2017 | LeFranc | | D12/195 |
| D793,315 | S | * | 8/2017 | Niemiec | | D12/195 |
| D796,403 | S | * | 9/2017 | Ahn | | D12/195 |

(73) Assignee: **IVECO S.p.A.**, Turin (IT)

(**) Term: **15 Years**

* cited by examiner

(21) Appl. No.: **29/597,346**

Primary Examiner — Katrina A Betton

(22) Filed: **Mar. 16, 2017**

(74) *Attorney, Agent, or Firm* — Stetina Brunda Garred & Brucker

(30) **Foreign Application Priority Data**

Sep. 19, 2016 (EM) 003385202

(51) **LOC (11) Cl.** **12-08**

(52) **U.S. Cl.**
USPC **D12/195**

(58) **Field of Classification Search**
USPC D12/195, 193, 414, 190, 196; D15/17,
D15/28; D10/46, 98, 102-103;
D8/302-303
CPC B60J 5/04; B60R 13/0243; B60R 13/02;
B60N 2/4693

See application file for complete search history.

(57) **CLAIM**

The ornamental design for a vehicle cockpit, as shown and described.

DESCRIPTION

FIG. 1 is a perspective view of a vehicle cockpit showing our new design;
FIG. 2 is a front view thereof;
FIG. 3 is a first side view thereof;
FIG. 4 is a second side view thereof; and,
FIG. 5 is a top plan view thereof.

1 Claim, 5 Drawing Sheets

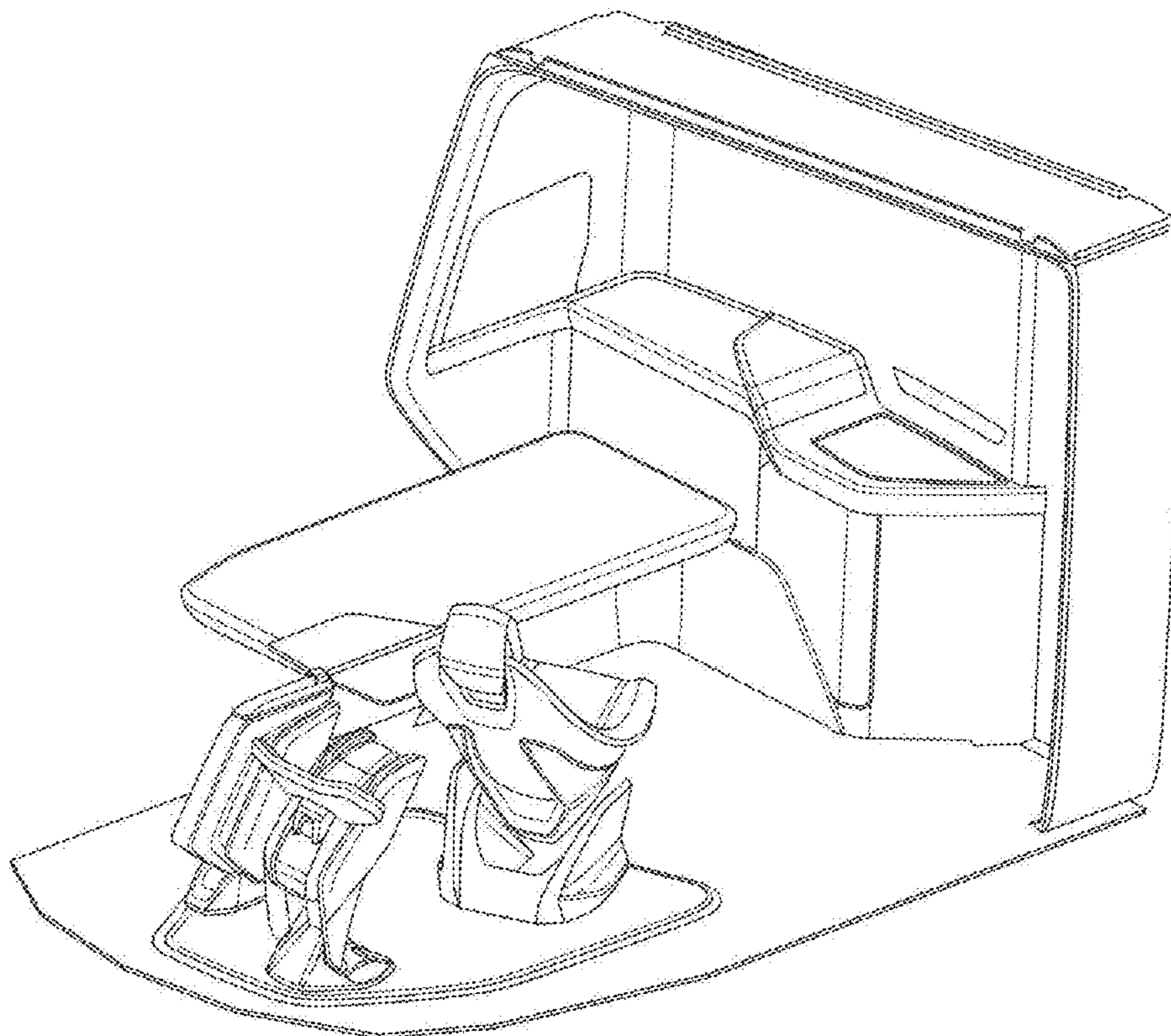

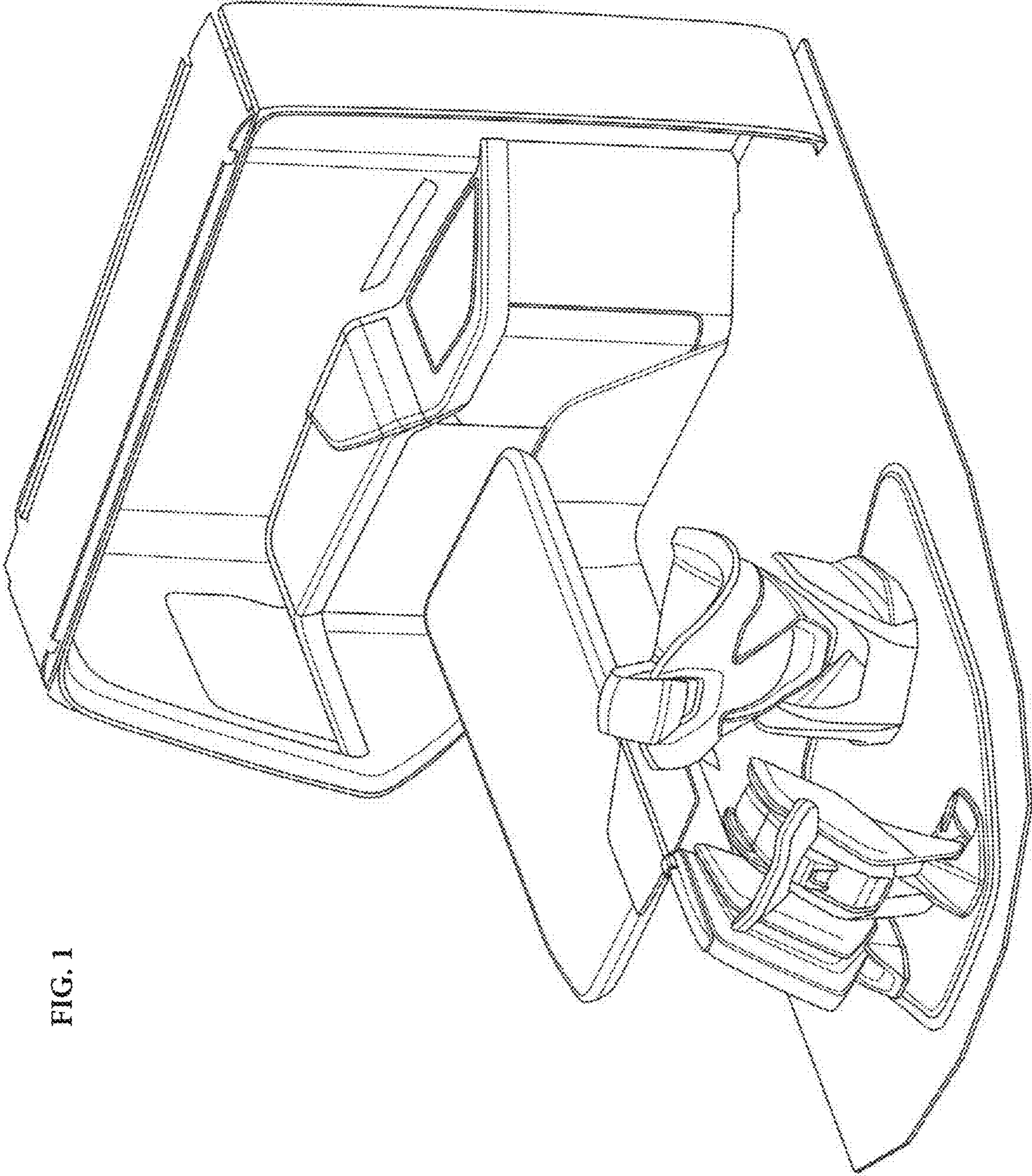

FIG. 1

FIG. 2

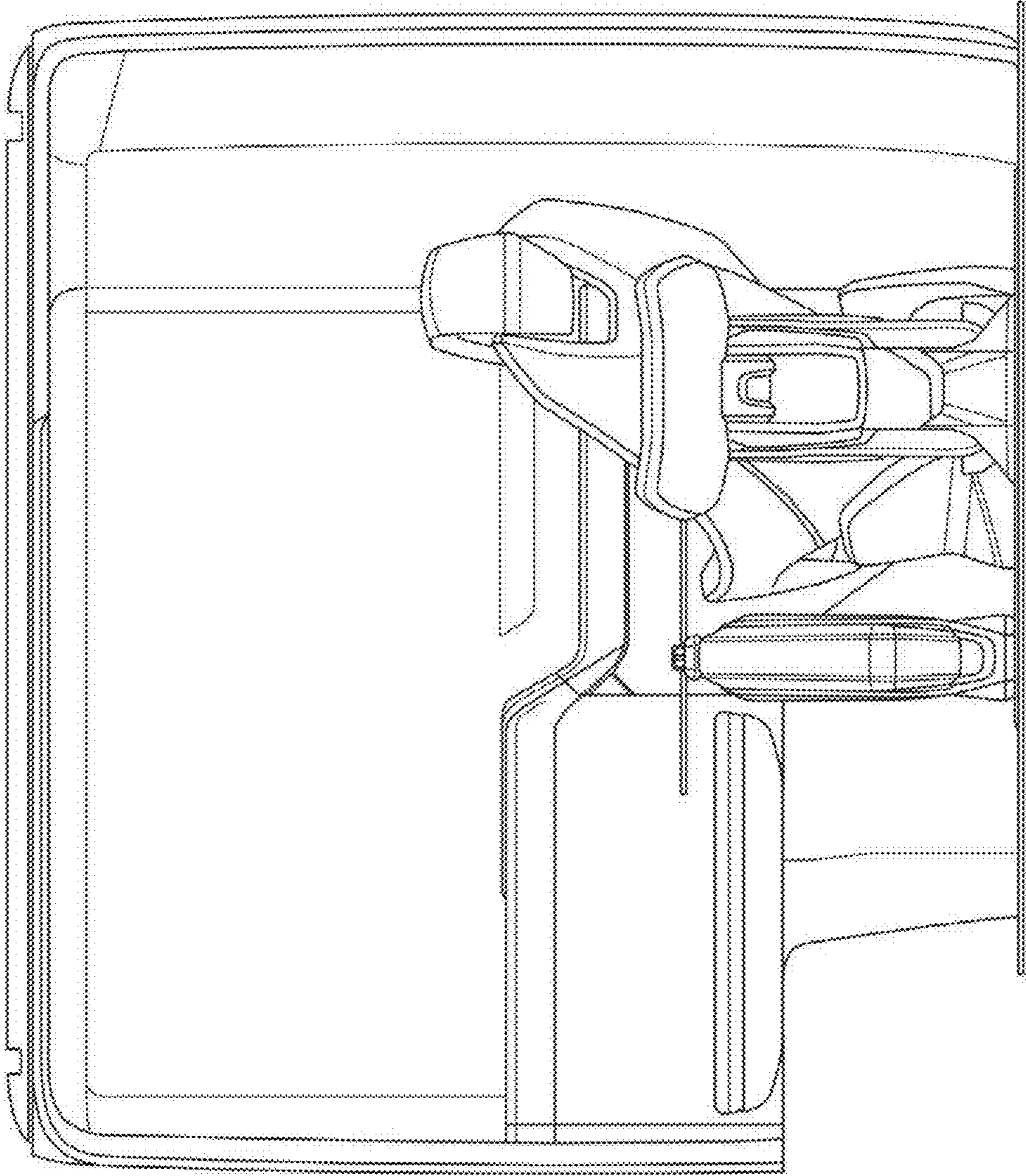

FIG. 3

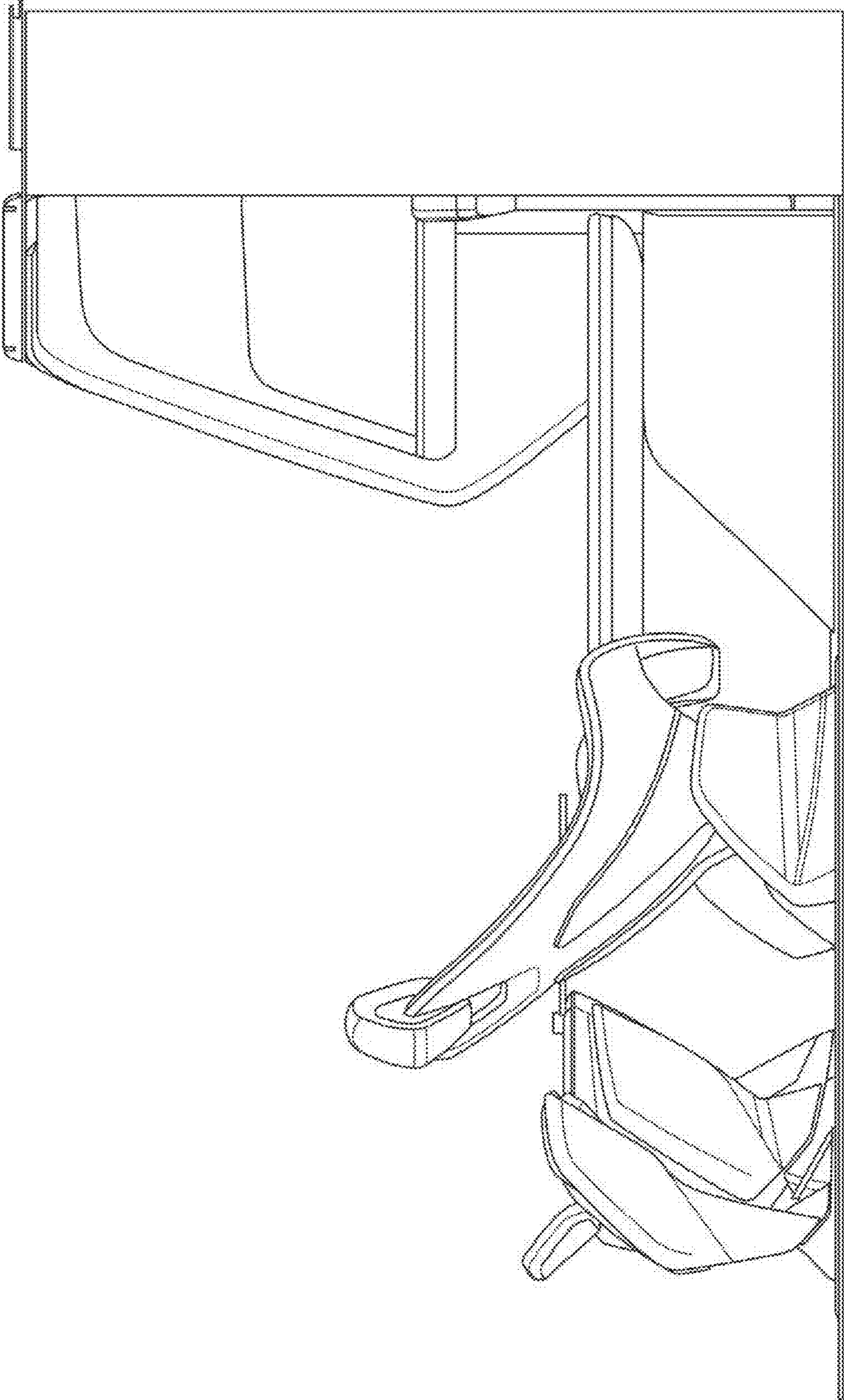

FIG. 4

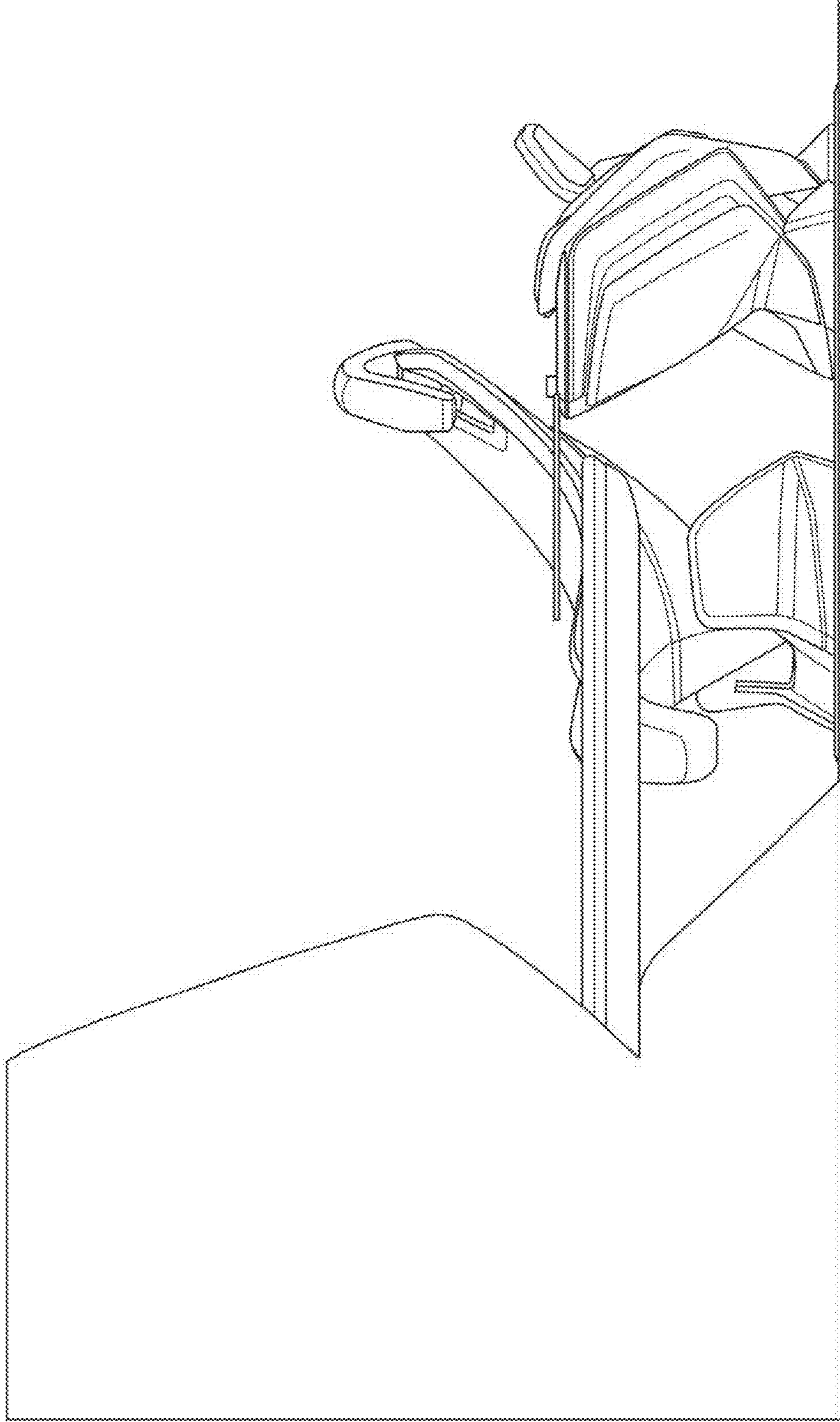

FIG. 5

