



US00D813103S

(12) **United States Design Patent**
Li et al.

(10) **Patent No.:** **US D813,103 S**
(45) **Date of Patent:** **** Mar. 20, 2018**

(54) **PERSONAL THREE-WHEELED VEHICLE**

(71) Applicants: **Guande Li**, Shengzhou (CN);
Hongliang Chen, Shengzhou (CN)

(72) Inventors: **Guande Li**, Shengzhou (CN);
Hongliang Chen, Shengzhou (CN)

(73) Assignee: **Shengzhou Zhonggong Electrical Co., Ltd**, Shengzhou, Zhejiang (CN)

(**) Term: **15 Years**

(21) Appl. No.: **29/555,641**

(22) Filed: **Feb. 24, 2016**

(30) **Foreign Application Priority Data**

Oct. 21, 2015 (CN) 201530406943.X

(51) **LOC (11) Cl.** **12-11**

(52) **U.S. Cl.**
USPC **D12/112; D12/1**

(58) **Field of Classification Search**
USPC D12/1, 8, 14, 85, 86, 112, 113, 128, 130;
D21/419, 421, 423, 424, 435
CPC B62K 1/00; B62K 3/002; B62K 3/007;
B62K 11/00; B62M 7/12; B60K 7/0007
See application file for complete search history.

(56) **References Cited**

U.S. PATENT DOCUMENTS

D528,468 S * 9/2006 Arling D12/1
D551,592 S * 9/2007 Chang D12/1
D569,308 S * 5/2008 Bergeron D12/7
D601,922 S * 10/2009 Imai D12/1
D614,998 S * 5/2010 Fujita D12/1

D619,045 S * 7/2010 Fujita D12/1
D626,884 S * 11/2010 Fujita D12/1
8,141,669 B1 * 3/2012 Laymaster B60K 7/0007
180/216
D699,626 S * 2/2014 Nam D12/1
D735,608 S * 8/2015 Cao D12/1
D748,533 S * 2/2016 Collins D12/1
2005/0134014 A1 * 6/2005 Xie B62D 51/001
280/93.502
2009/0078485 A1 * 3/2009 Gutsch A01D 34/67
180/218
2009/0115149 A1 * 5/2009 Wallis B60N 2/002
280/6.159
2013/0153322 A1 * 6/2013 Constin B62B 1/002
180/212
2015/0046002 A1 * 2/2015 Shih B62K 1/00
701/22

* cited by examiner

Primary Examiner — Darlington Ly

(57) **CLAIM**

The ornamental design for a personal three-wheeled vehicle, as shown and described.

DESCRIPTION

FIG. 1 is a top, front, and left side perspective view of a personal three-wheeled vehicle showing my new design; FIG. 2 is a front elevation view thereof; FIG. 3 is a rear elevation view thereof; FIG. 4 is a right side elevation view thereof; FIG. 5 is a left side elevation view thereof; and, FIG. 6 is a top plan view thereof. The broken lines in the drawings illustrate portions of the personal three-wheeled vehicle that forms no part of the claimed design.

1 Claim, 6 Drawing Sheets

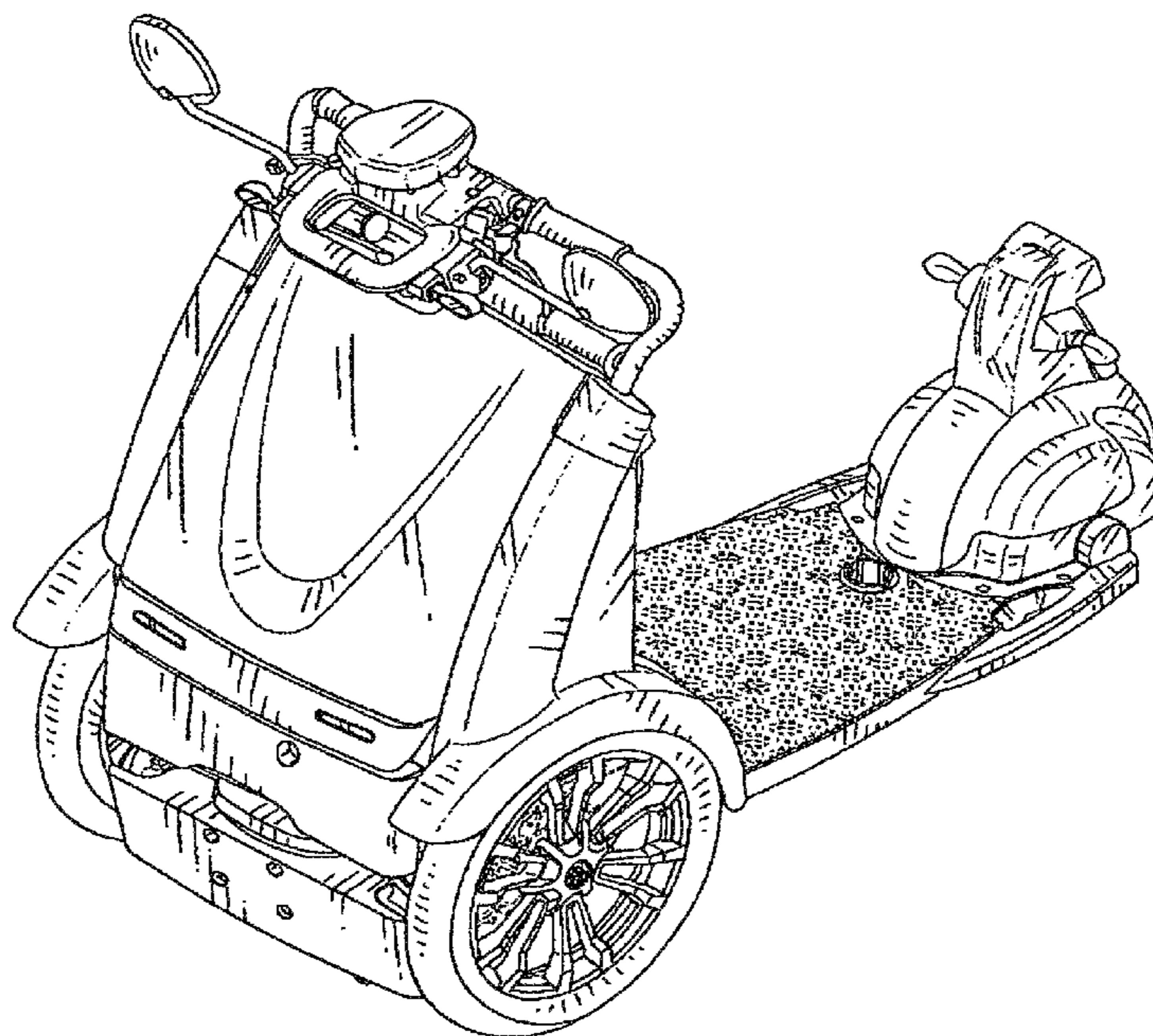

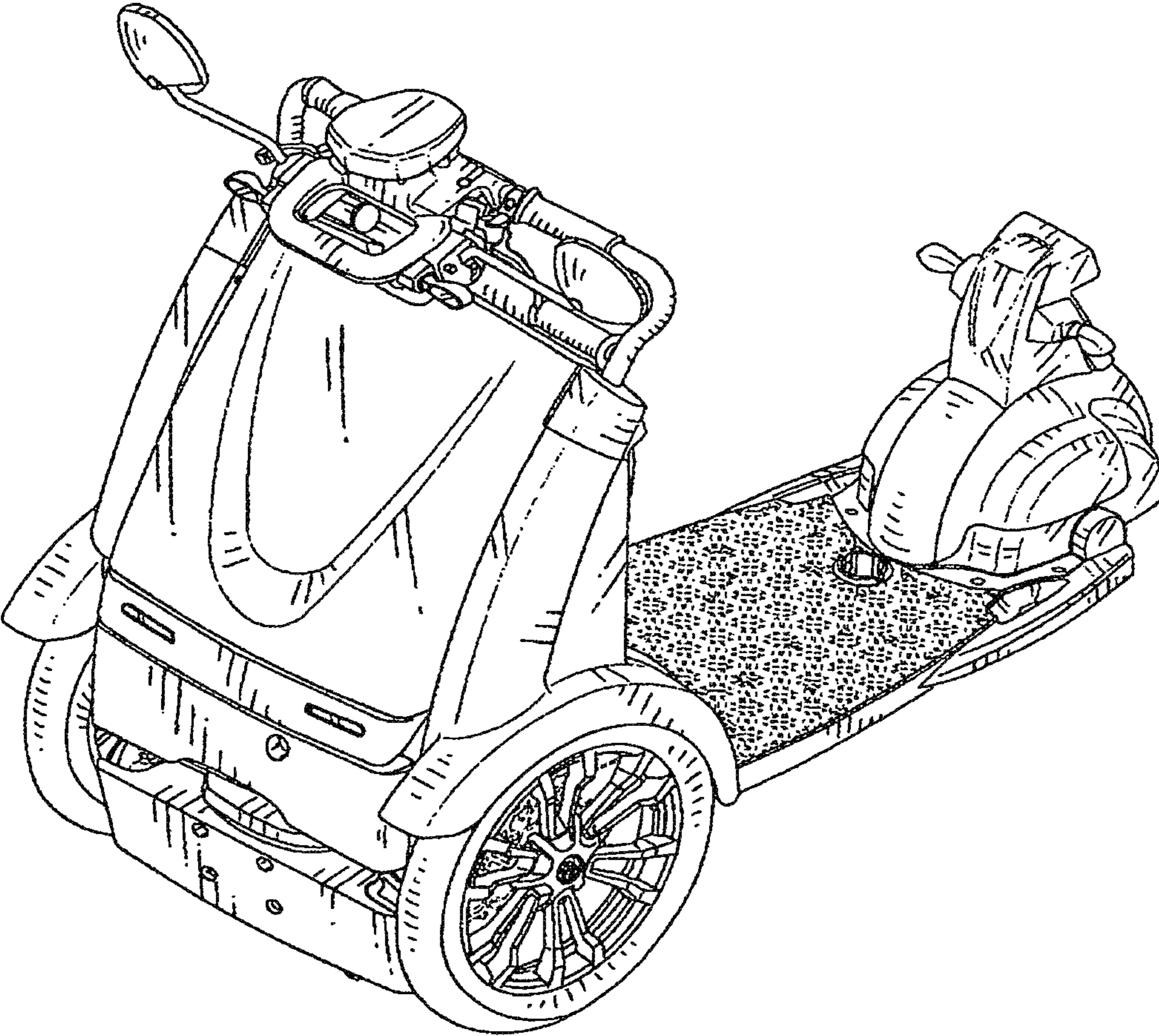

Fig.1

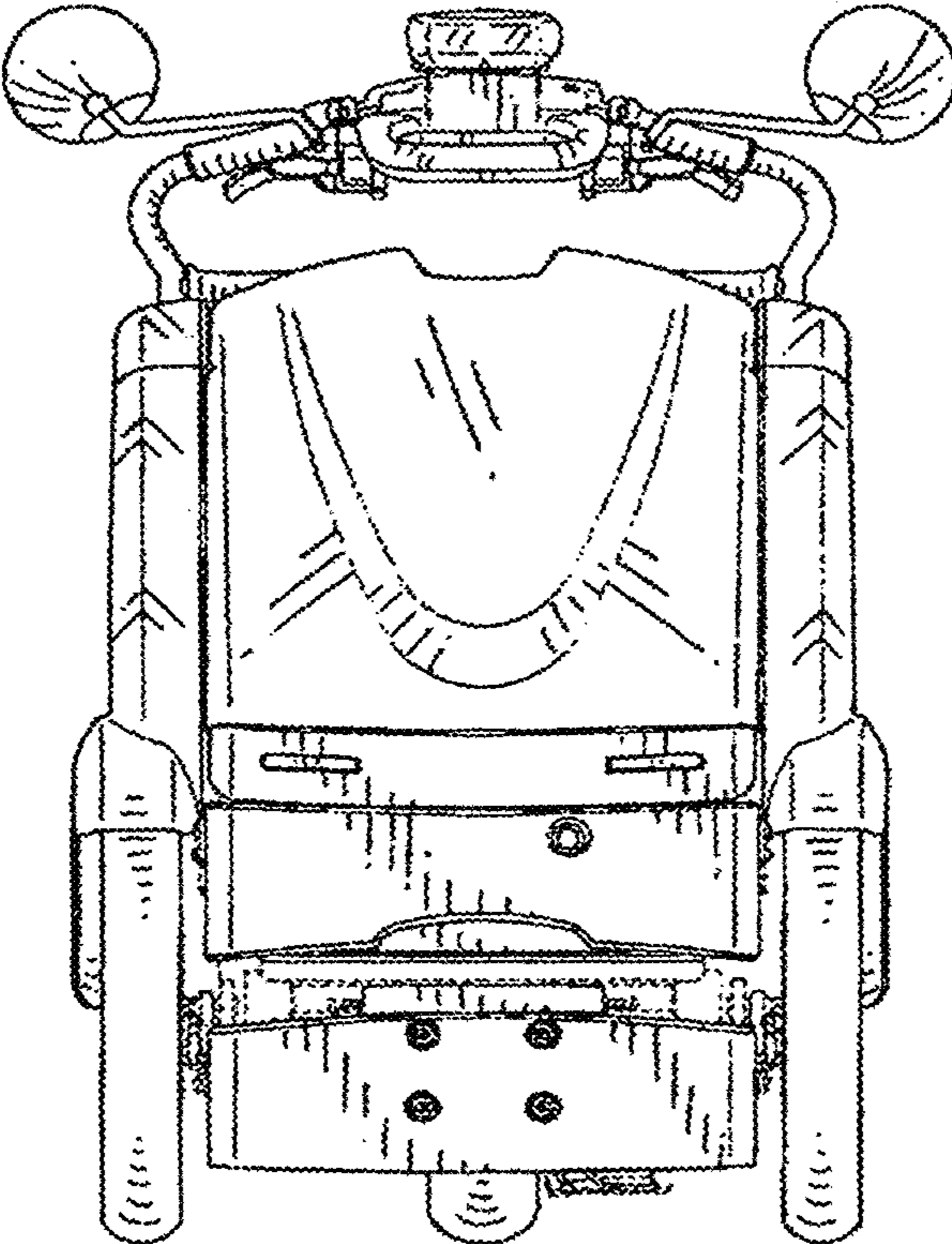

Fig.2

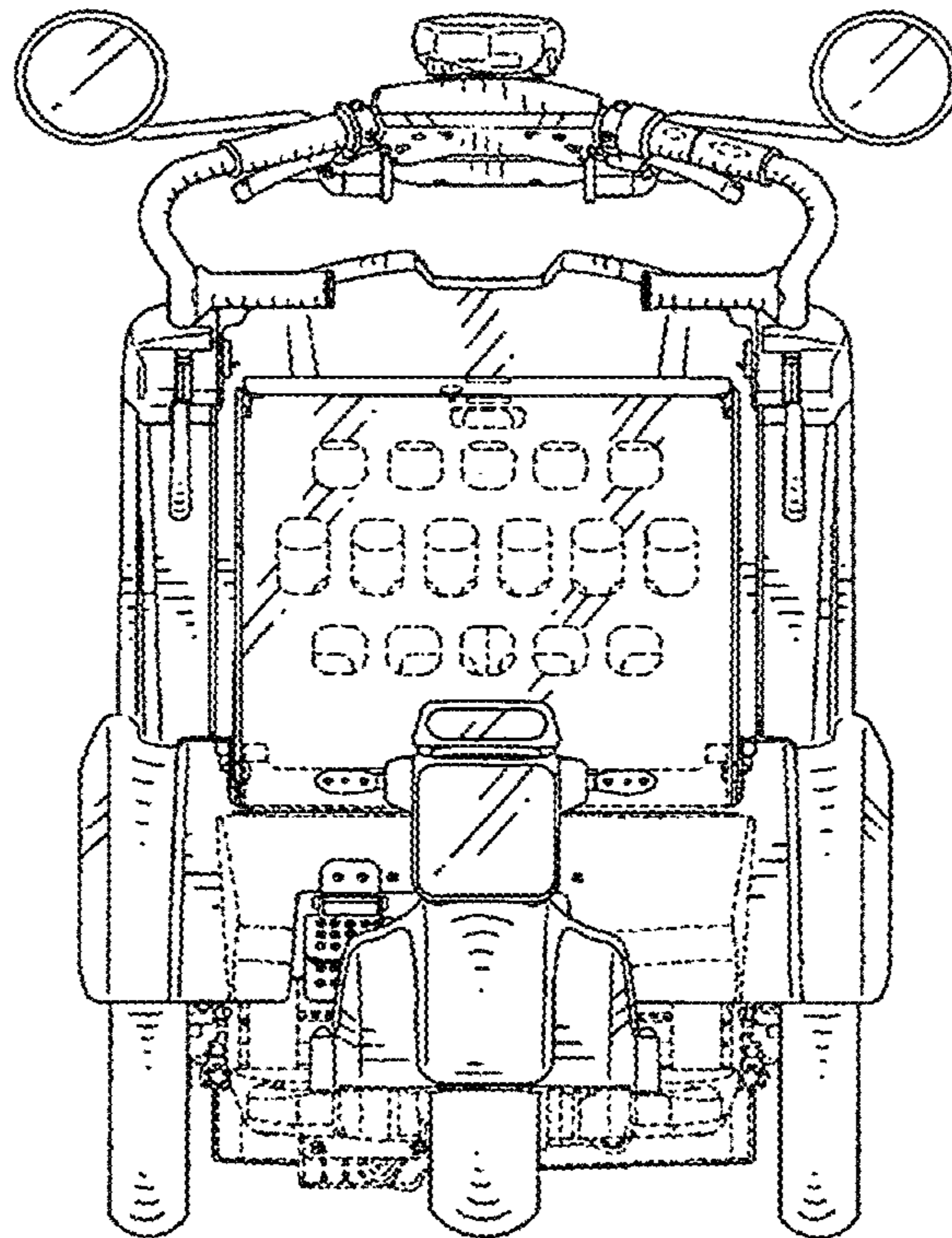

Fig.3

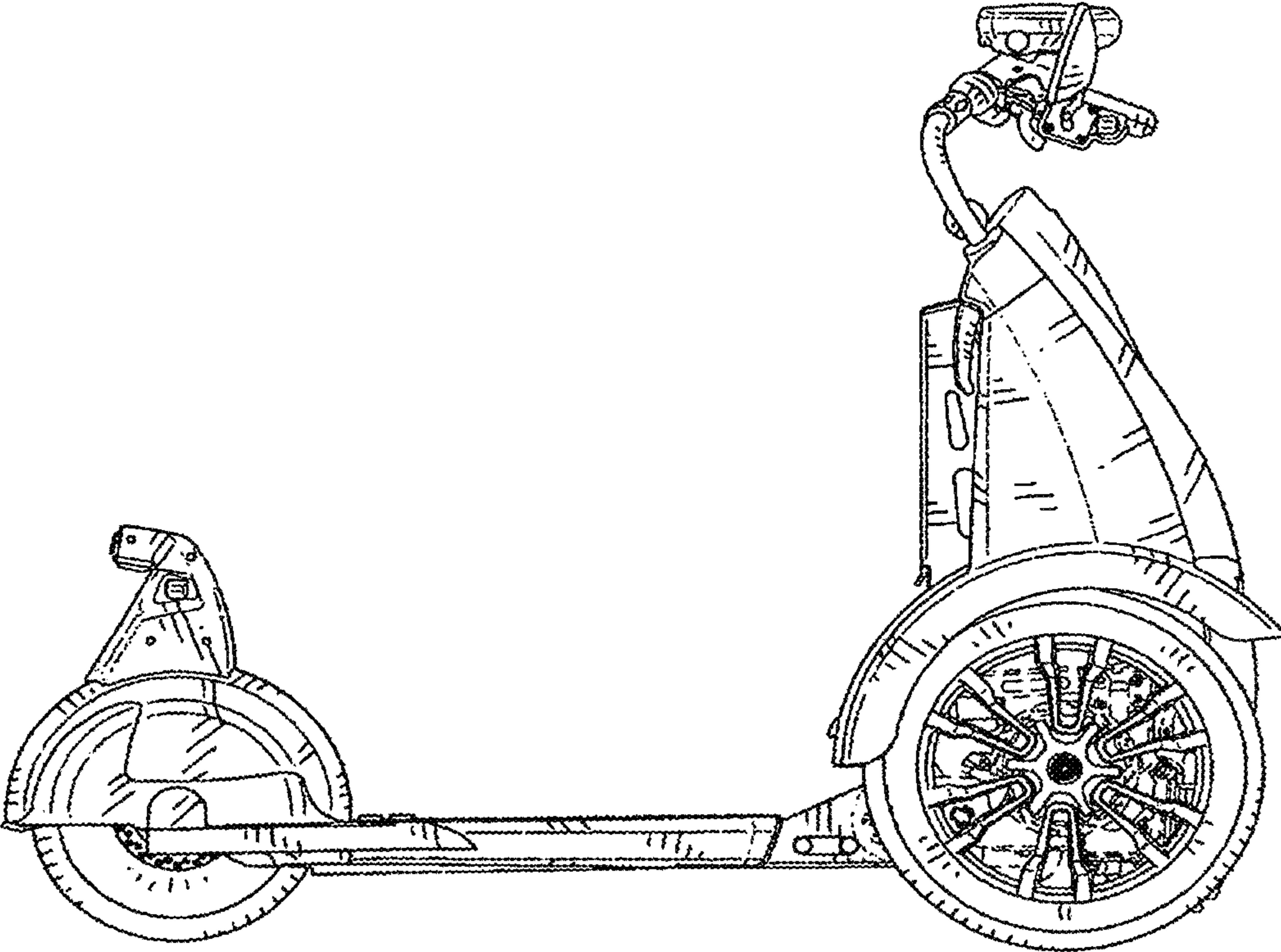

Fig.4

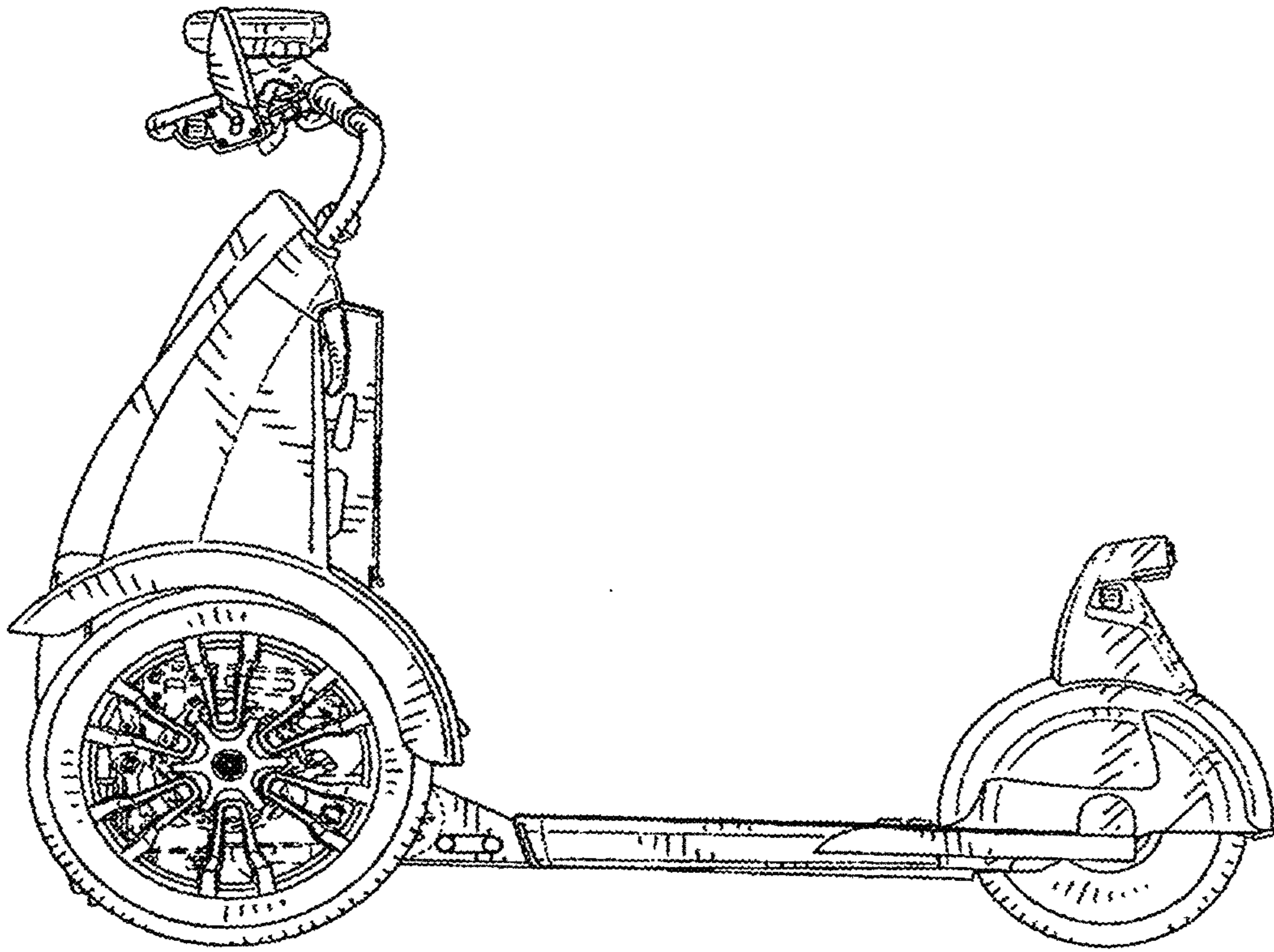

Fig.5

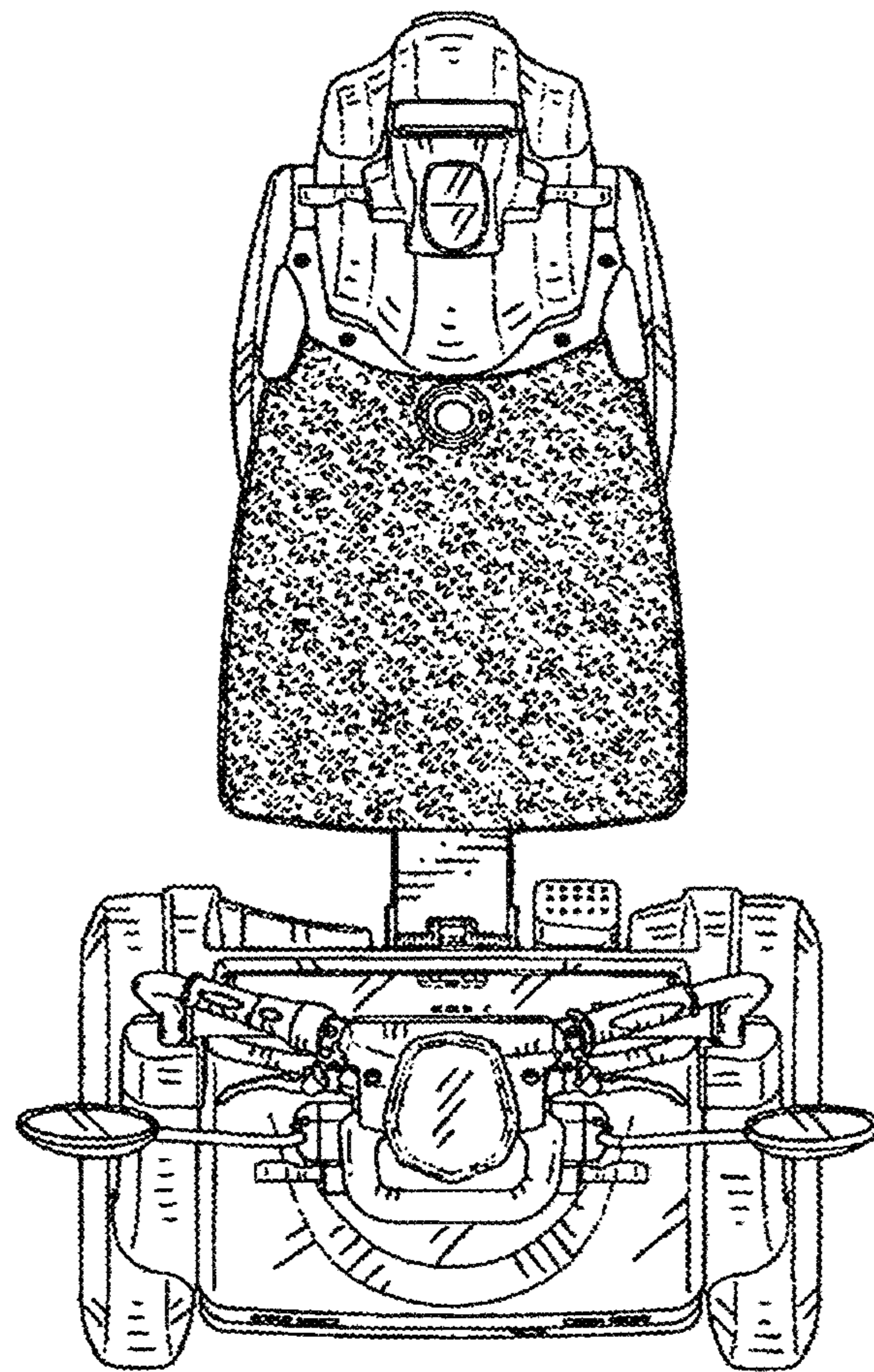

Fig.6