



US00D813098S

(12) **United States Design Patent**
Thompson et al.

(10) **Patent No.:** **US D813,098 S**
(45) **Date of Patent:** **** Mar. 20, 2018**

- (54) **VEHICLE BODY EXTERIOR**
- (71) Applicant: **GM GLOBAL TECHNOLOGY OPERATIONS LLC**, Detroit, MI (US)
- (72) Inventors: **Justin James Thompson**, Clarinda (AU); **Peter William Hughes**, Pascoe Vale (AU)
- (73) Assignee: **GM Global Technology Operations LLC**, Detroit, MI (US)
- (**) Term: **15 Years**
- (21) Appl. No.: **29/559,247**
- (22) Filed: **Mar. 25, 2016**
- (51) **LOC (11) Cl.** **12-08**
- (52) **U.S. Cl.**
USPC **D12/92**
- (58) **Field of Classification Search**
USPC D12/86, 90-92, 88; D21/421, 433, 434;
296/181.1, 181.5
CPC B62D 35/00; B62D 25/00; B62D 25/06;
B62D 33/00
See application file for complete search history.

- D608,690 S 1/2010 Folden et al.
- D608,691 S 1/2010 Zak, Jr. et al.
- D609,608 S 2/2010 Boniface et al.
- D611,387 S 3/2010 Thompson et al.
- D611,879 S 3/2010 Kim et al.
- D612,297 S 3/2010 Peters et al.
- D613,645 S 4/2010 Song et al.
- D615,458 S 5/2010 Thompson et al.
- D618,595 S 6/2010 Ware et al.
- D623,090 S 9/2010 Cox et al.
- D627,262 S 11/2010 Ikeda et al.
- D635,488 S 4/2011 Phipps
- D644,147 S 8/2011 Suh et al.
- D644,567 S 9/2011 Kozub
- D657,718 S 4/2012 Zipfel et al.
- D659,052 S 5/2012 Ware et al.
- D659,053 S 5/2012 Ware et al.
- D668,182 S 10/2012 Barba Franco et al.
- D668,183 S 10/2012 Smart
- D678,820 S 3/2013 Son et al.
- D678,821 S 3/2013 Ikeda et al.

(Continued)

Primary Examiner — Melody N Brown

(74) *Attorney, Agent, or Firm* — Reising Ethington P.C.

(57) **CLAIM**

The ornamental design for a vehicle body exterior, as shown and described.

DESCRIPTION

FIG. 1 is a front and left side perspective view of a vehicle body exterior showing our new design; FIG. 2 is a front and left side perspective view thereof; FIG. 3 is a left side elevation view thereof, the right side elevational being a mirror image thereof; FIG. 4 is a top plan view thereof; and, FIG. 5 is a rear elevation view thereof. The broken lines shown in the drawings depict portions of the vehicle body exterior that form no part of the claimed design.

1 Claim, 4 Drawing Sheets

(56) **References Cited**
U.S. PATENT DOCUMENTS

- D570,742 S 6/2008 Takagi et al.
- D592,105 S 5/2009 Dean et al.
- D597,447 S 8/2009 Folden
- D600,595 S 9/2009 Nakamura et al.
- D601,925 S 10/2009 O'Donnell
- D603,755 S 11/2009 Peters
- D604,203 S 11/2009 O'Donnell
- D605,082 S 12/2009 Munson
- D605,083 S 12/2009 Manoogian, II et al.
- D605,977 S 12/2009 Zipfel et al.
- D605,978 S 12/2009 Wolff et al.
- D608,249 S 1/2010 Peters

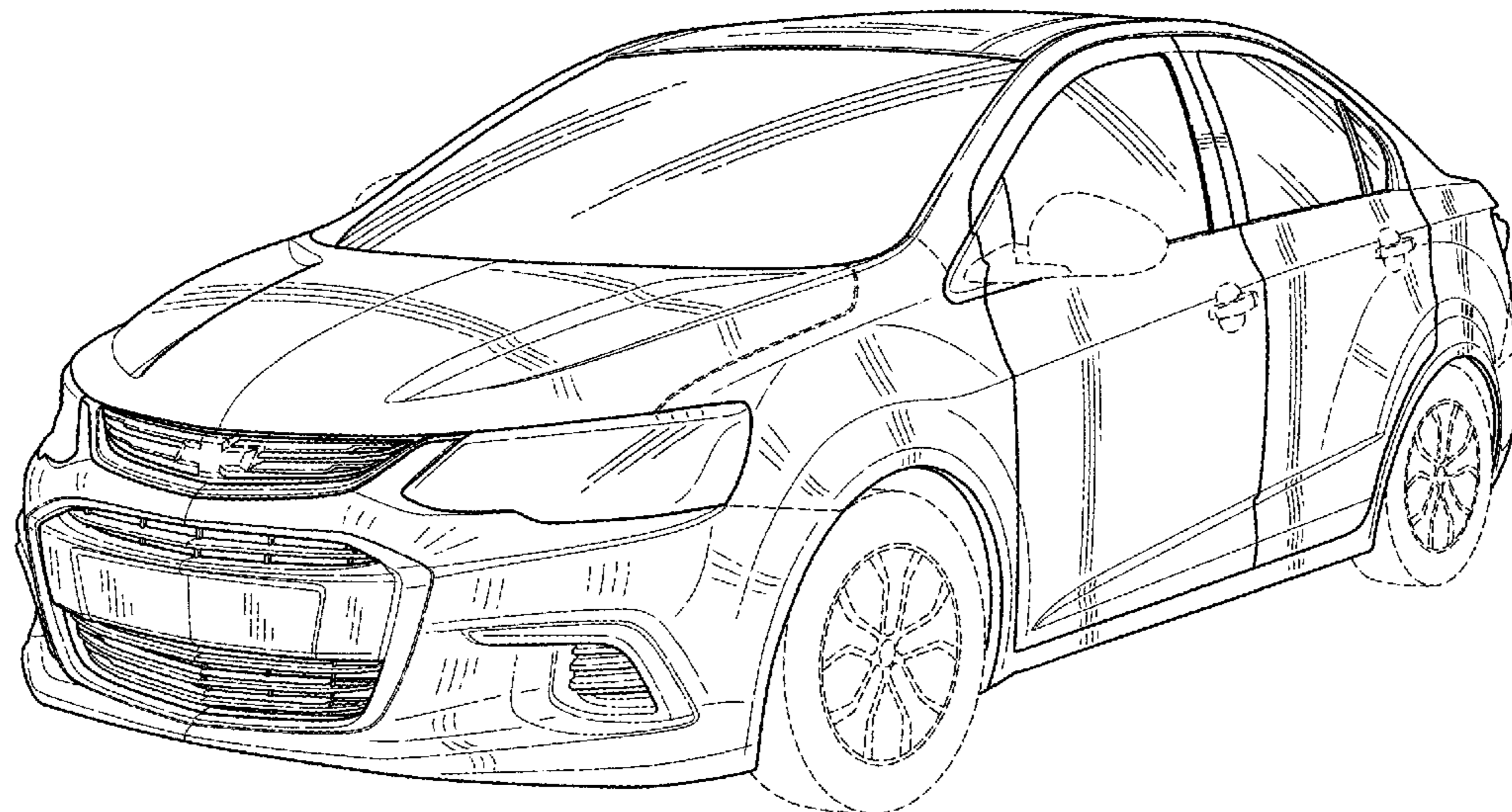

(56)

References Cited

U.S. PATENT DOCUMENTS

D680,909 S 4/2013 Munson et al.
 D680,910 S 4/2013 David
 D684,899 S 6/2013 Baker
 D686,536 S 7/2013 McCabe et al.
 D692,798 S 11/2013 Thurber
 D692,799 S 11/2013 Smith et al.
 D696,157 S 12/2013 Loeb
 D699,629 S 2/2014 Ikeda et al.
 D700,871 S 3/2014 O'Donnell et al.
 D703,103 S 4/2014 Lee
 D704,103 S 5/2014 Mack et al.
 D705,132 S 5/2014 Ware et al.
 D705,699 S 5/2014 Ware et al.
 D713,298 S 9/2014 Dyson
 D713,764 S 9/2014 Ferlazzo et al.
 D716,696 S 11/2014 Thole et al.
 D716,706 S 11/2014 Thole et al.
 D716,709 S 11/2014 Thole et al.
 D717,696 S 11/2014 Thole et al.
 D718,189 S 11/2014 Krieg et al.
 D718,683 S 12/2014 Thole et al.
 D722,282 S 2/2015 Loeb
 D722,533 S 2/2015 Thole et al.
 D722,534 S 2/2015 Munson et al.
 D724,510 S 3/2015 McMahan et al.
 D725,001 S 3/2015 McMahan et al.
 D726,591 S 4/2015 Jacob
 D730,776 S 6/2015 Smart
 D730,783 S 6/2015 Henriques et al.
 D732,427 S 6/2015 Loeb
 D732,429 S 6/2015 Loeb
 D732,430 S 6/2015 Loeb
 D732,431 S 6/2015 Loeb
 D732,432 S 6/2015 Aengenheyster
 D732,433 S 6/2015 Aengenheyster
 D732,435 S 6/2015 Mackay
 D733,002 S 6/2015 Loeb

D735,611 S 8/2015 Aengenheyster
 D735,627 S 8/2015 Smith
 D736,451 S 8/2015 Smith
 D739,306 S 9/2015 McMahan
 D739,317 S 9/2015 McMahan et al.
 D741,223 S 10/2015 Kim et al.
 D743,309 S 11/2015 Thole et al.
 D743,313 S 11/2015 Smith et al.
 D743,314 S 11/2015 Thole et al.
 D743,857 S 11/2015 McMahan et al.
 D744,158 S 11/2015 Willett et al.
 D745,086 S 12/2015 Finos et al.
 D745,719 S 12/2015 Boniface et al.
 D745,725 S 12/2015 McMahan et al.
 D745,726 S 12/2015 McMahan et al.
 D745,837 S 12/2015 Smith et al.
 D746,726 S 1/2016 Smith et al.
 D746,727 S 1/2016 Smith et al.
 D746,728 S 1/2016 Smith et al.
 D746,729 S 1/2016 Boniface et al.
 D746,730 S 1/2016 Kim et al.
 D747,514 S 1/2016 McMahan et al.
 D747,515 S 1/2016 McMahan et al.
 D747,819 S 1/2016 Thole et al.
 D749,021 S 2/2016 Boniface et al.
 D749,026 S 2/2016 Smith et al.
 D749,027 S 2/2016 McMahan et al.
 D749,246 S 2/2016 Thole et al.
 D749,249 S 2/2016 Thole et al.
 D749,250 S 2/2016 Thole et al.
 D749,985 S 2/2016 Kozub et al.
 D749,997 S 2/2016 McMahan et al.
 D750,001 S 2/2016 Thole et al.
 D767,449 S * 9/2016 Pevovar D12/92
 D767,451 S * 9/2016 Kozub D12/92
 D777,605 S * 1/2017 Ferlazzo D12/92
 D780,631 S * 3/2017 Kozub D12/91
 D797,603 S * 9/2017 Noone D12/91

* cited by examiner

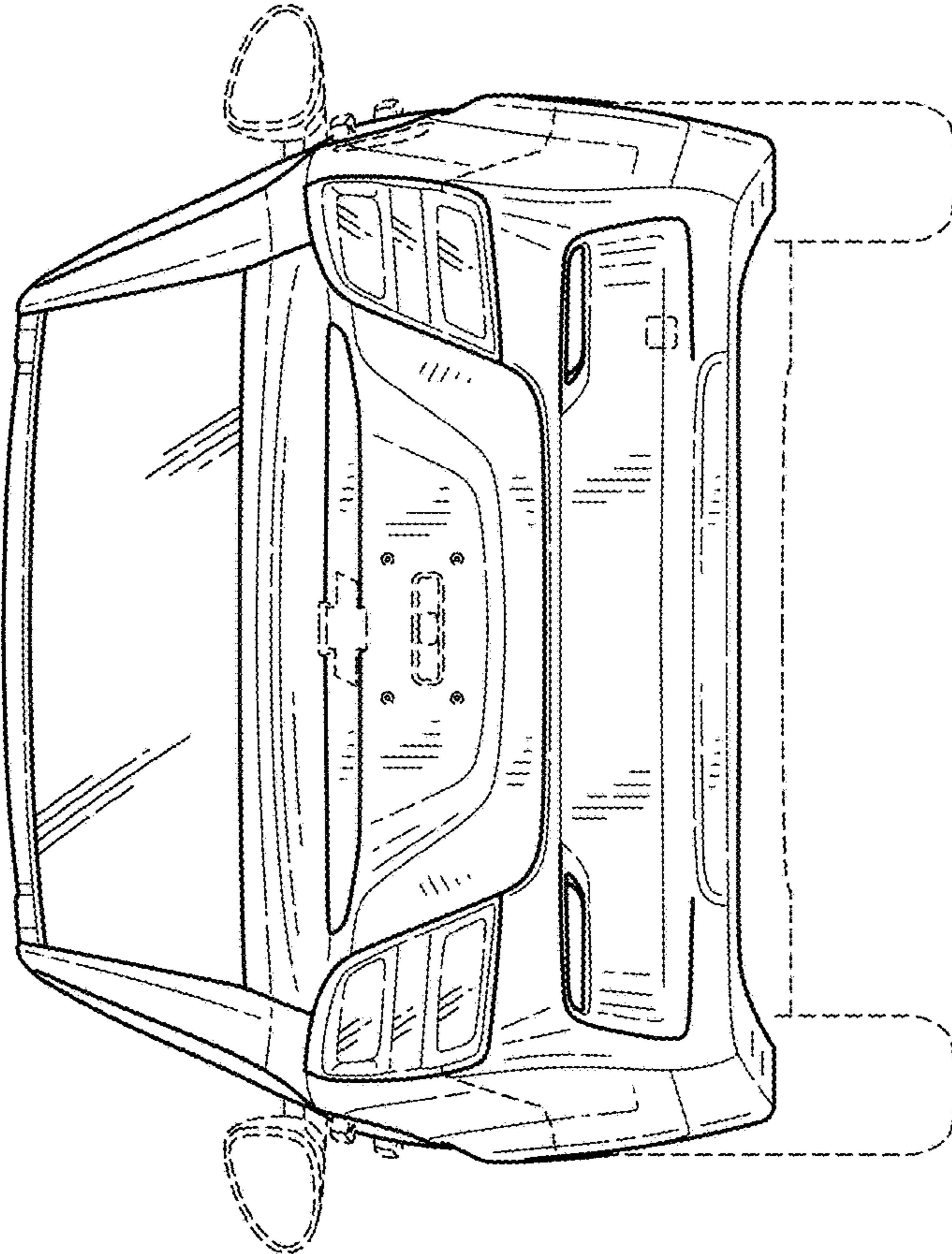

FIG. 5

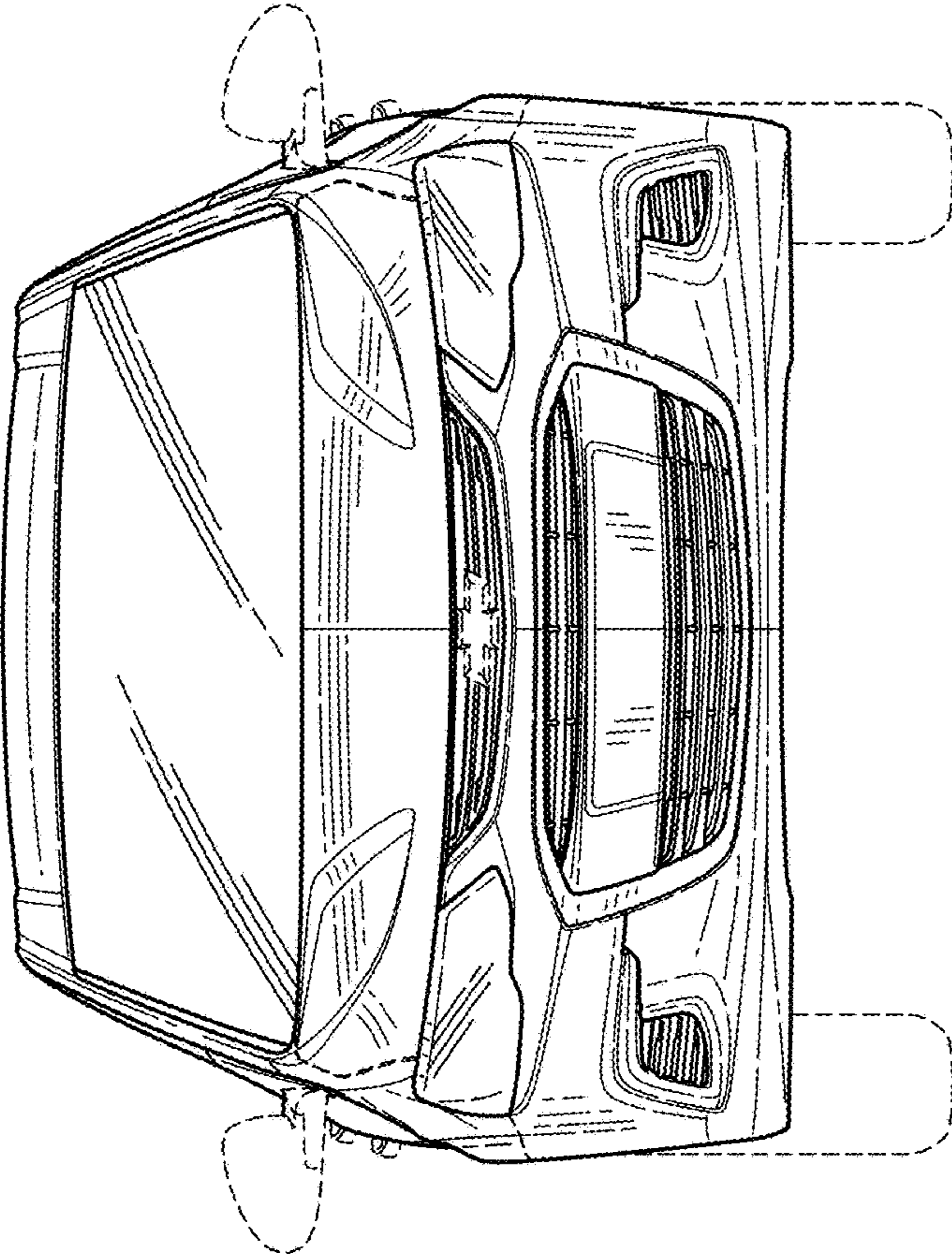

FIG. 1

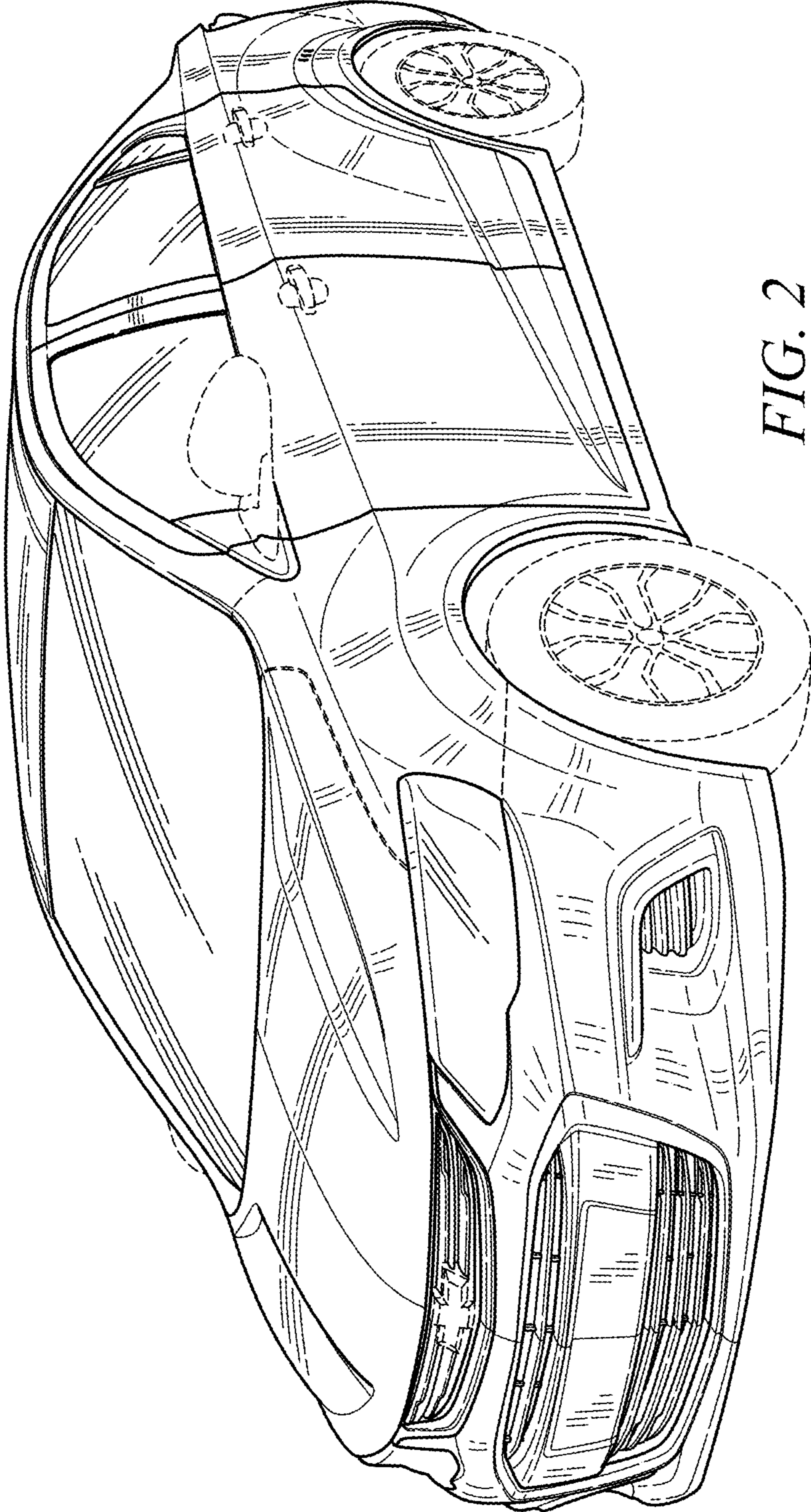

FIG. 2

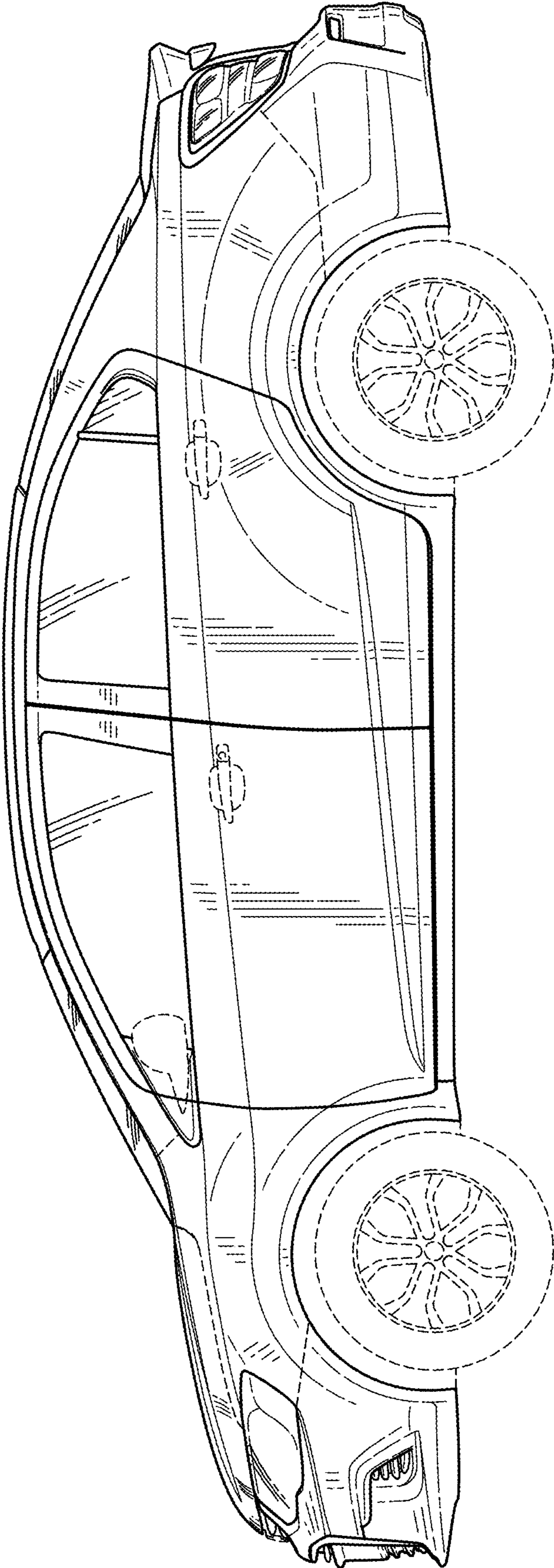

FIG. 3

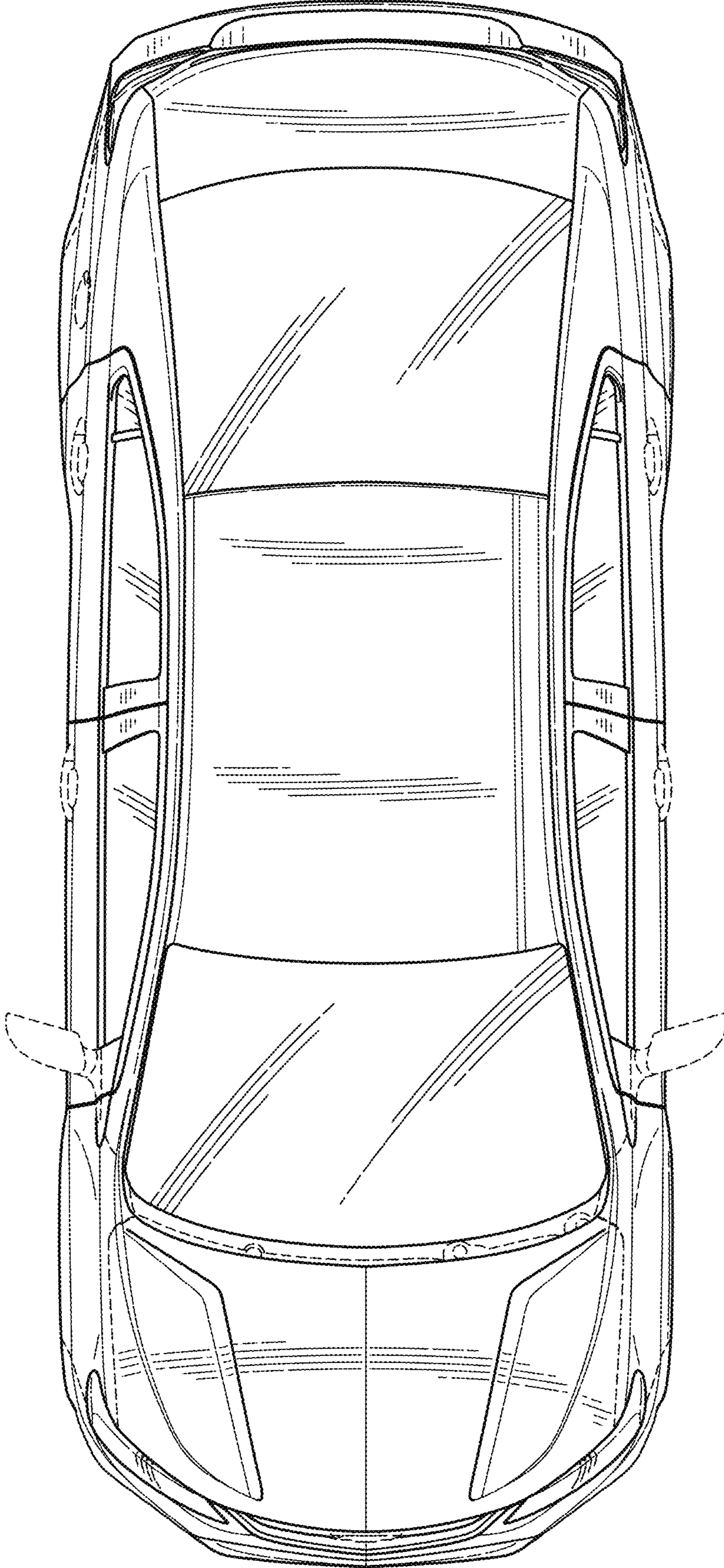

FIG. 4