



US00D812969S

(12) **United States Design Patent**
Premkumar

(10) **Patent No.:** **US D812,969 S**
(45) **Date of Patent:** **** Mar. 20, 2018**

- (54) **BEVERAGE CONTAINER LID**
- (71) Applicant: **DYLA LLC**, West New York, NJ (US)
- (72) Inventor: **Neel Premkumar**, West New York, NJ (US)
- (73) Assignee: **DYLA LLC**, West New York, NJ (US)
- (**) Term: **15 Years**
- (21) Appl. No.: **29/571,074**
- (22) Filed: **Jul. 14, 2016**
- (51) **LOC (11) Cl.** **07-01**
- (52) **U.S. Cl.**
USPC **D7/396.2**; D9/454
- (58) **Field of Classification Search**
USPC D3/202; D7/300, 321, 392.1, 396.2, 397, D7/398, 500, 507, 509, 510, 511, 900; D9/434, 435, 437, 439, 440, 447, 452, D9/453, 454, 500, 504, 505, 516, 549, D9/558, 575, 715, 721, 763, 772, 779, D9/780; D34/7, 10, 11
CPC A47G 19/2211; A47G 19/2266; A47G 19/2272; A45F 3/16; B65D 39/00; B65D 39/16; B65D 43/06; B65D 43/08; B65D 45/00; B65D 45/30; B65D 45/305; B65D 51/16; B65D 51/66
See application file for complete search history.

D618,500 S * 6/2010 Hardaway D7/396.2
D652,675 S * 1/2012 Miller D7/402
D682,108 S * 5/2013 Berggren D9/454
(Continued)

OTHER PUBLICATIONS

Forto Strong Coffee Energy Drink: Announced Jun. 16, 2016 [online], site visited Aug. 16, 2017. Available from Internet URL: <http://famadillo.com/forto-strong-coffee-energy-drink/>.
(Continued)

Primary Examiner — Jennifer Rivard
Assistant Examiner — Catherine S Posthauer
(74) *Attorney, Agent, or Firm* — Greenberg Traurig, LLP

(57) **CLAIM**

The ornamental design for a beverage container lid, as shown and described.

DESCRIPTION

FIG. 1 is a top perspective view of my beverage container lid on a beverage container showing the novel lid design. FIG. 2 is a side elevational view, as viewed from any compass direction, of the beverage container lid shown in FIG. 1. FIG. 3 is a top plan view of the beverage container lid shown in FIG. 1. FIG. 4 is a bottom plan view of the beverage container lid shown in FIG. 3; and, FIG. 5 is an enlarged partial view of my beverage container lid shown in FIG. 1. The broken lines are shown for the purpose of illustrating environmental subject matter of a beverage container as well as parts of the lid, none of which form part of the claim. The “Forto Strong Coffee” logo shown in FIGS. 1 and 3 is a registered trademark of Dyla LLC and forms no part of the claim. The dot-dash broken lines are shown for the purpose of designating the enlargement view of FIG. 5, as well as the origin of this view on FIG. 1.

1 Claim, 4 Drawing Sheets

(56) **References Cited**

U.S. PATENT DOCUMENTS

- D271,945 S * 12/1983 Ochs D9/452
- D286,026 S * 10/1986 Rayner D9/435
- D327,808 S * 7/1992 Kline D7/391
- D526,158 S * 8/2006 Laib D7/392.1
- D526,840 S * 8/2006 Carlson D7/392.1
- D563,157 S * 3/2008 Bouveret D7/392.1
- D581,792 S * 12/2008 Krohn D9/504

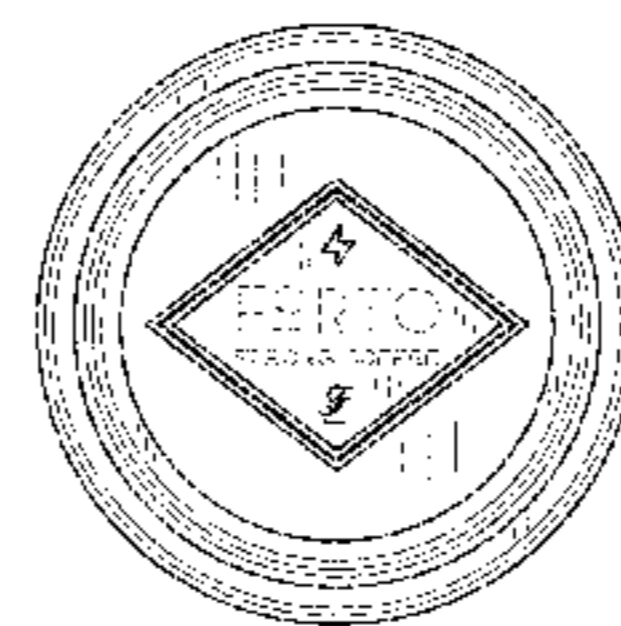
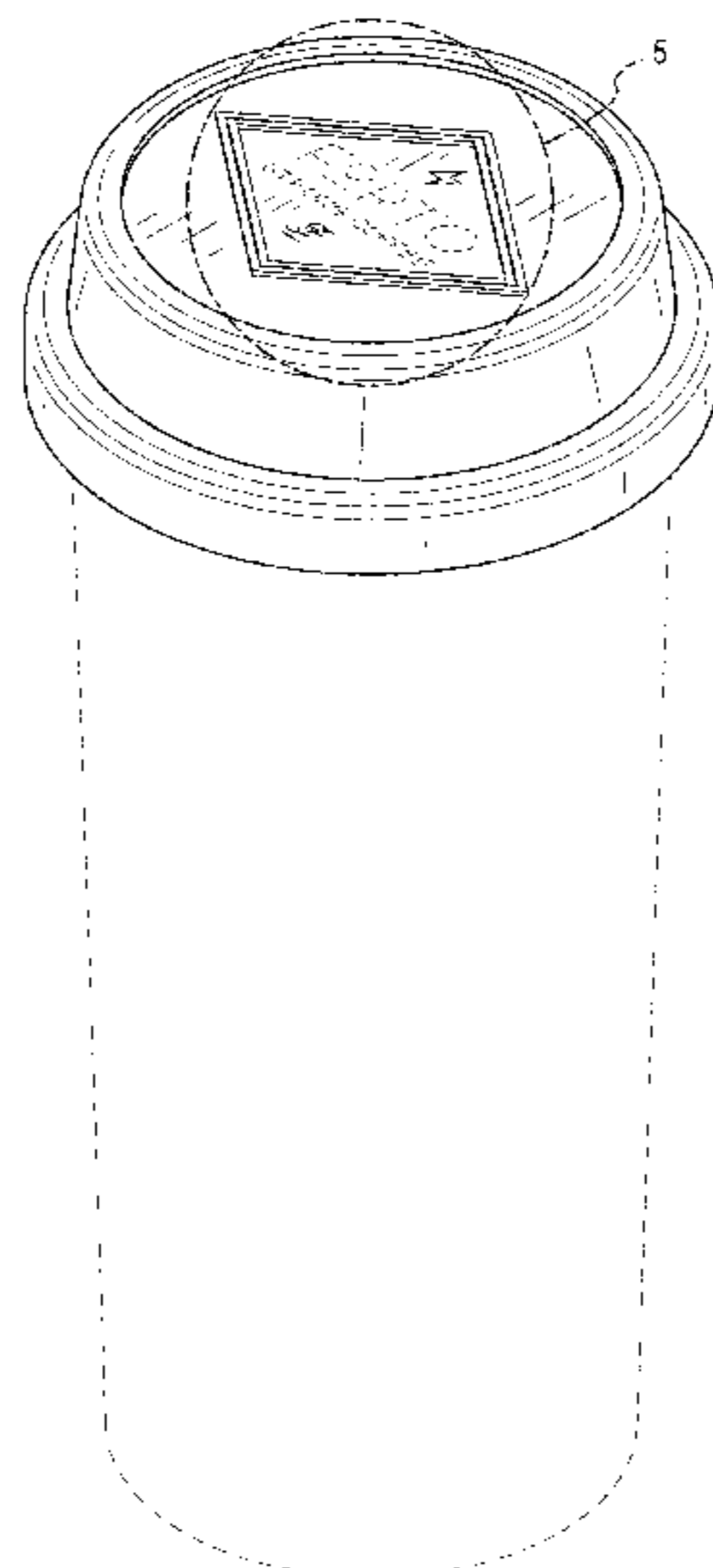

(56)

References Cited

U.S. PATENT DOCUMENTS

D682,610 S * 5/2013 Carder D7/392.1
D700,512 S * 3/2014 Daniel D9/447
D710,696 S * 8/2014 Kwon D7/392.1
D711,744 S * 8/2014 Humm D9/447
D712,256 S * 9/2014 Humm D9/447
D739,729 S * 9/2015 Brannock D9/447
D784,072 S * 4/2017 Baron D7/392.1
D792,738 S * 7/2017 Savenok D7/392.1
2008/0112459 A1 * 5/2008 Salkeld A47G 19/2272
374/141
2016/0075492 A1 * 3/2016 Brannock B65D 43/0212
220/712
2016/0345762 A1 * 12/2016 Brannock A47G 19/2272
2017/0112306 A1 * 4/2017 Muir, III A47G 19/2211

OTHER PUBLICATIONS

Forto Strong Coffee: Announced May 9, 2017 [online], site visited Aug. 16, 2017. Available from Internet URL: <https://www.amazon.com/FORTO-organic-Coffee-Energy-caffeine/dp/B06XTG2PNR/#customerReviews>.*

* cited by examiner

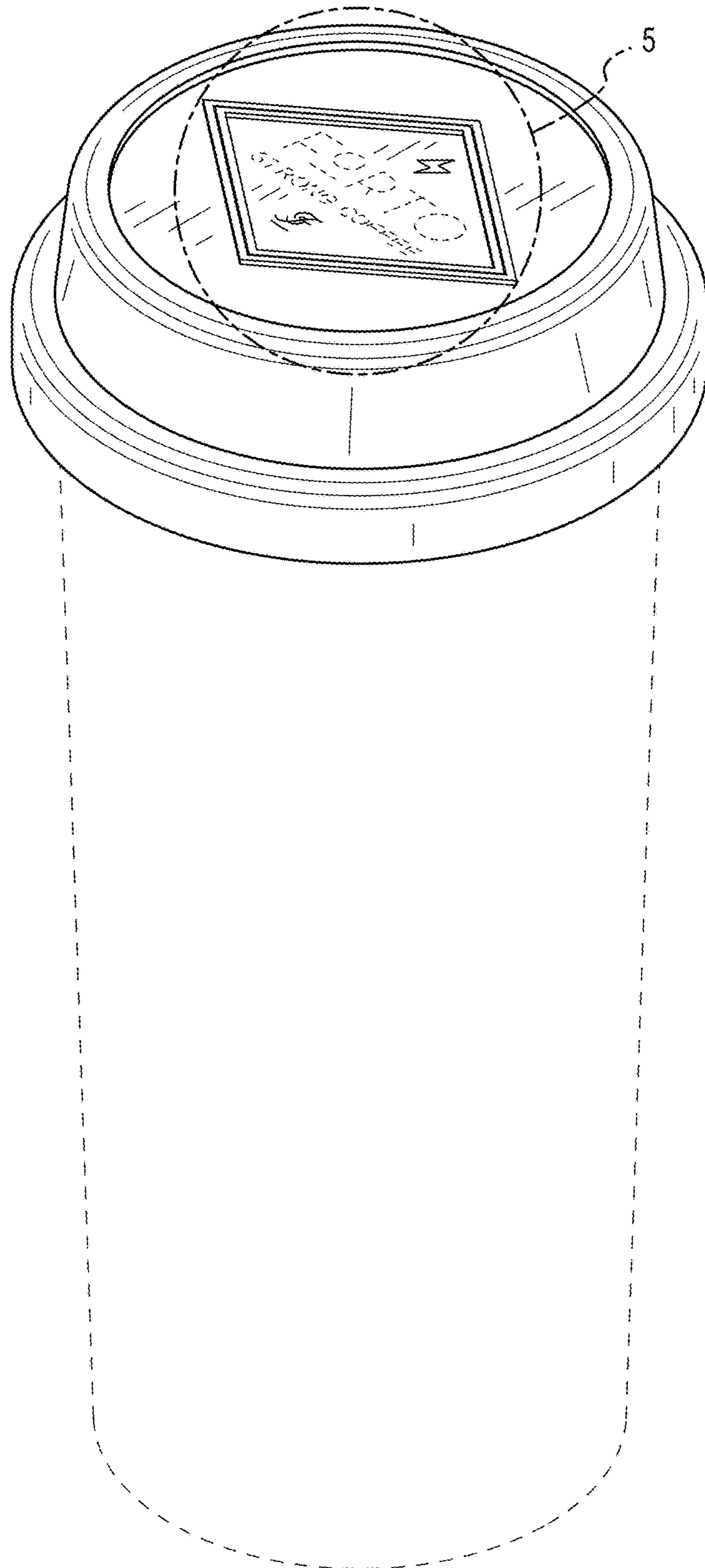

FIG.1

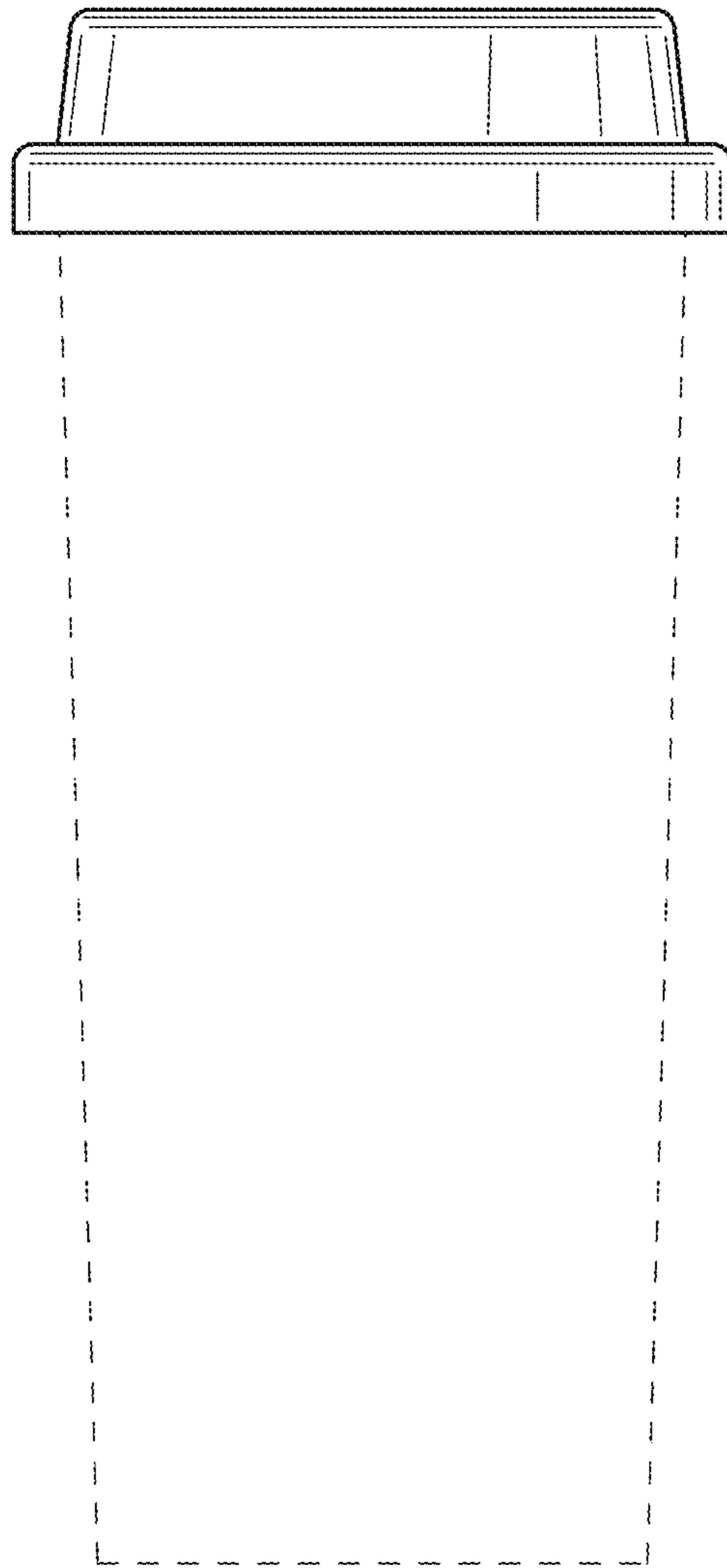

FIG.2



FIG.3

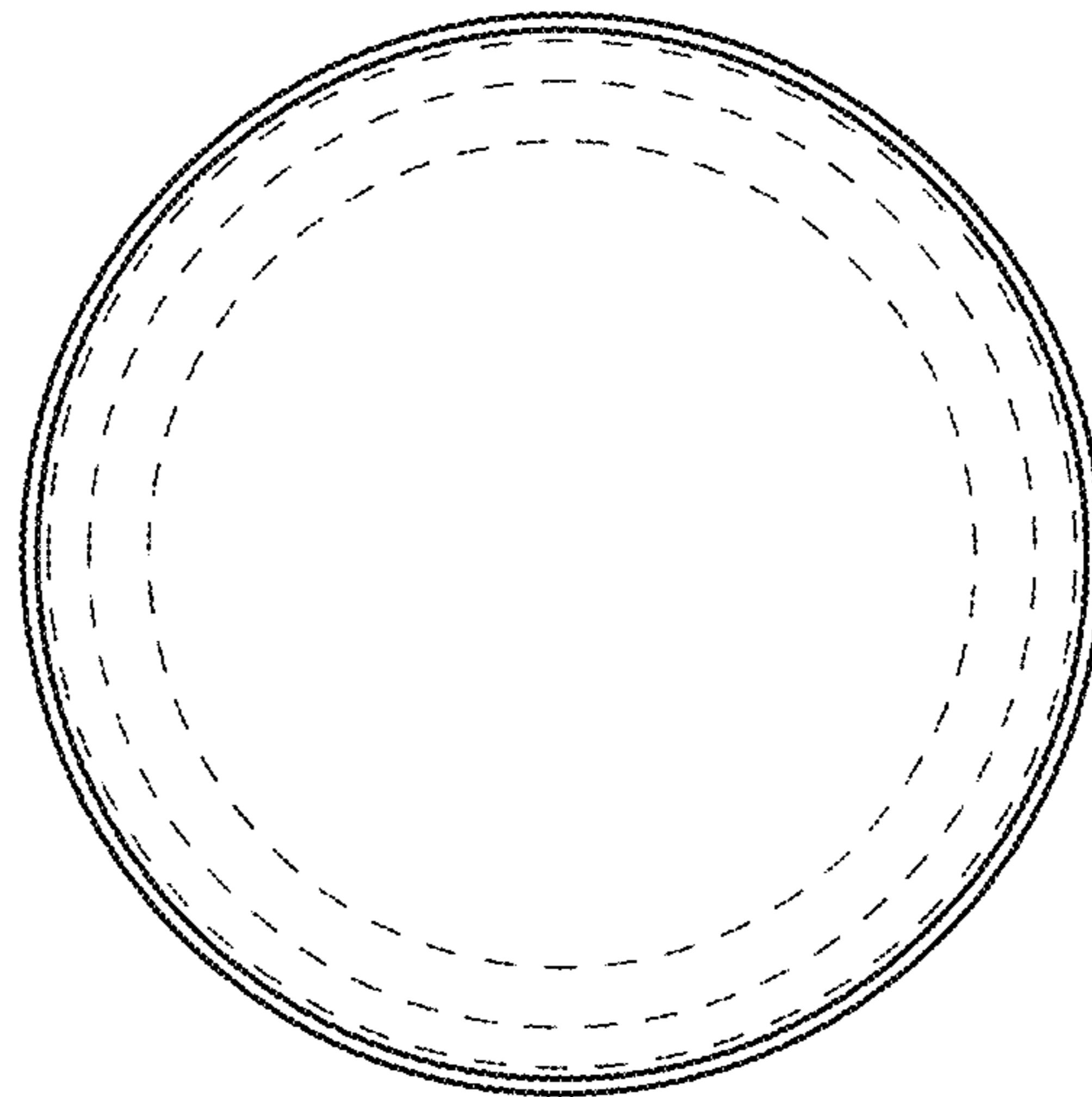

FIG.4

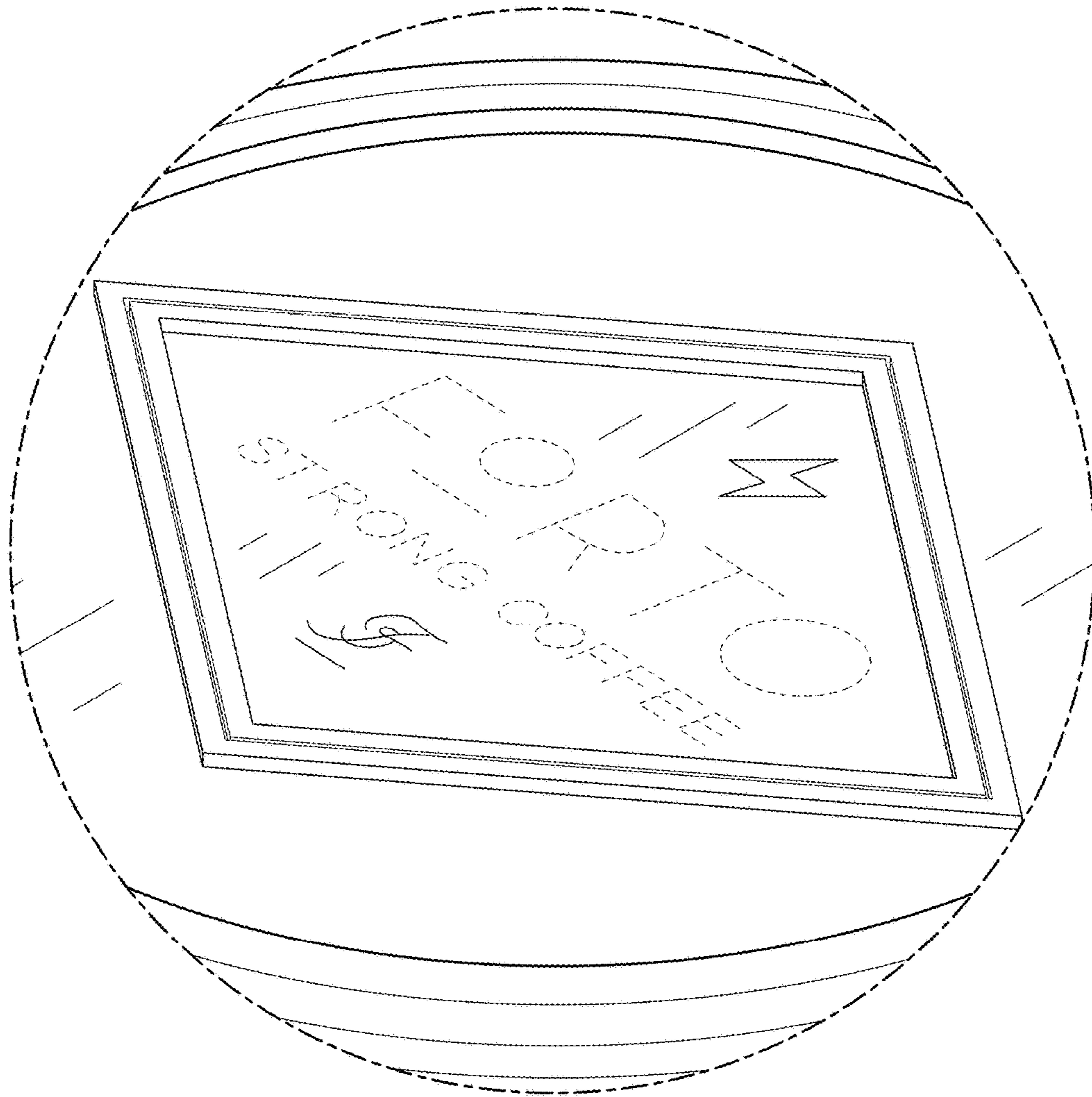

FIG.5