



US00D812921S

(12) **United States Design Patent** (10) **Patent No.:** **US D812,921 S**
Vorwerk (45) **Date of Patent:** **** *Mar. 20, 2018**

(54) **SEATS**
(71) Applicant: **United Commercial Upholstery, Inc.,**
New Ulm, MN (US)
(72) Inventor: **Christina J. Vorwerk,** Courtland, MN
(US)

D618,137 S * 6/2010 Yuan D12/16
D640,594 S * 6/2011 Zhang D12/16
D652,349 S * 1/2012 Kristensen D12/16
8,191,966 B1 * 6/2012 Longenette B60N 2/6018
297/218.1
D683,977 S * 6/2013 Ashley D6/356
D684,385 S * 6/2013 Ashley D6/356

(*) Notice: This patent is subject to a terminal disclaimer.

* cited by examiner

(**) Term: **15 Years**

Primary Examiner — Mimososa De

(21) Appl. No.: **29/585,979**

(57) **CLAIM**

(22) Filed: **Nov. 30, 2016**

The ornamental design for the seats, as shown and described.

(51) **LOC (11) Cl.** **06-01**

DESCRIPTION

(52) **U.S. Cl.**

USPC **D6/356**

(58) **Field of Classification Search**

USPC .. D6/334-336, 356, 374, 716, 716.1, 716.4;
D12/16; D21/433; D34/15
CPC ... B60N 2/00; B60N 2/02; B60N 2/38; B60N
2/6018; A47C 17/23; A47C 31/00; B60R
25/04

See application file for complete search history.

FIG. 1 is an illustration of an isometric view of seats mounted in a golf cart;
FIG. 2 is an illustration of another isometric view of the seats;
FIG. 3 is an illustration of a front view of the seats;
FIG. 4 is an illustration of a right side view of the seats;
FIG. 5 is an illustration of a left side view of the seats;
FIG. 6 is an illustration of a rear view of the seats;
FIG. 7 is an illustration of a top view of the seats; and,
FIG. 8 is an illustration of a bottom view of the seats.

(56) **References Cited**

U.S. PATENT DOCUMENTS

D245,592 S * 8/1977 Davidson D12/16
5,048,894 A * 9/1991 Miyajima B60N 2/38
297/452.11
D395,023 S * 6/1998 Hikida D12/16
D483,079 S * 12/2003 Wang D21/433
D483,694 S * 12/2003 Bellington D12/16
D498,704 S * 11/2004 Bonner D12/16
D515,971 S * 2/2006 Essig D12/16
D617,681 S * 6/2010 Tuo D12/16

The broken lines in the seats of FIG. 1 represent portions of the seats which are not part of the claimed design. The remainder of the broken lines shown in FIG. 1 represents a golf cart which is not part of the claimed design. The broken lines in FIGS. 2, 4, 5, 7 and 8 represent portions of the seats which are not part of the claimed design. The dot-dash lines in FIGS. 6 and 8 demarcate areas of the seats which are not part of the claimed design.

1 Claim, 8 Drawing Sheets

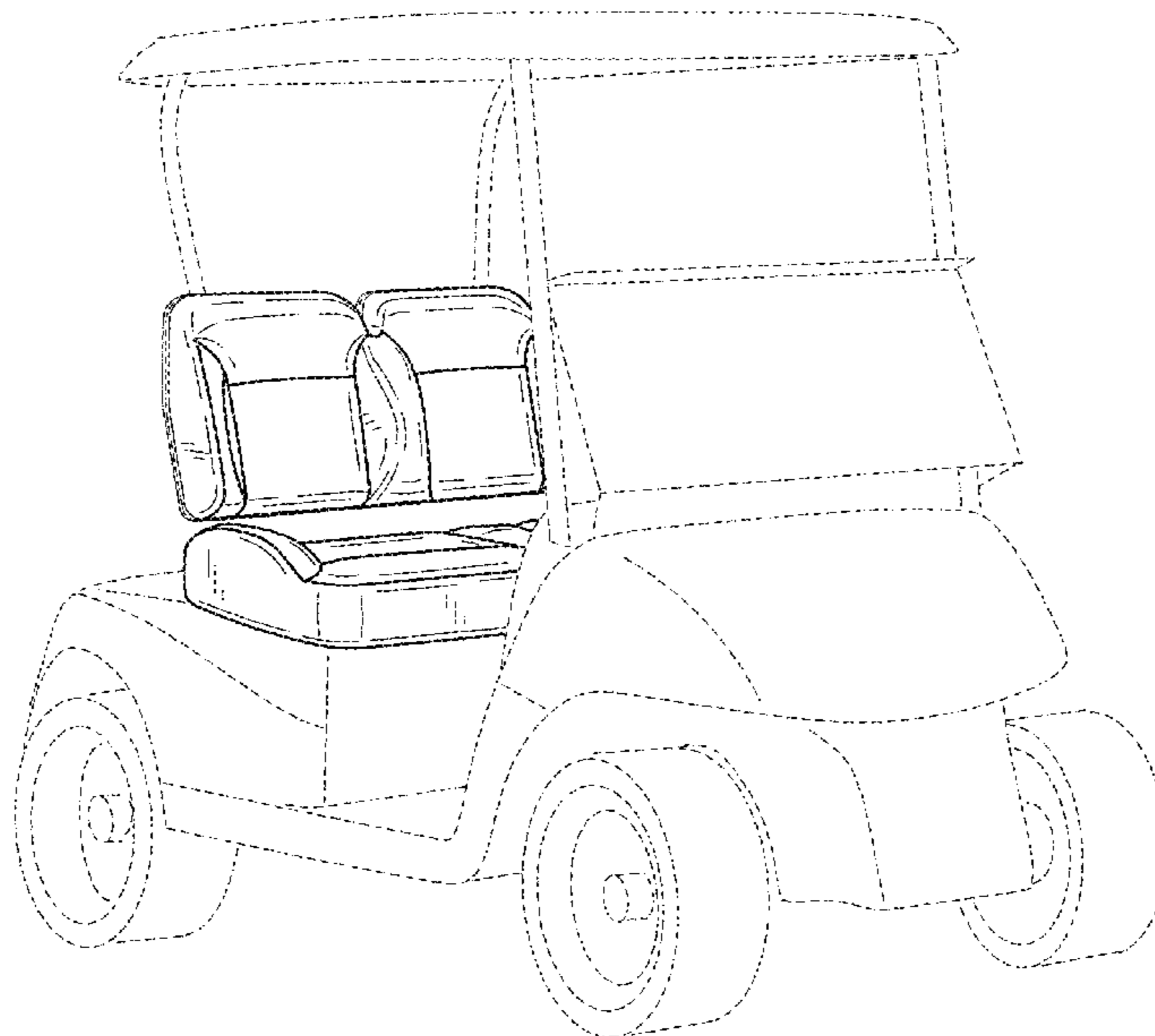

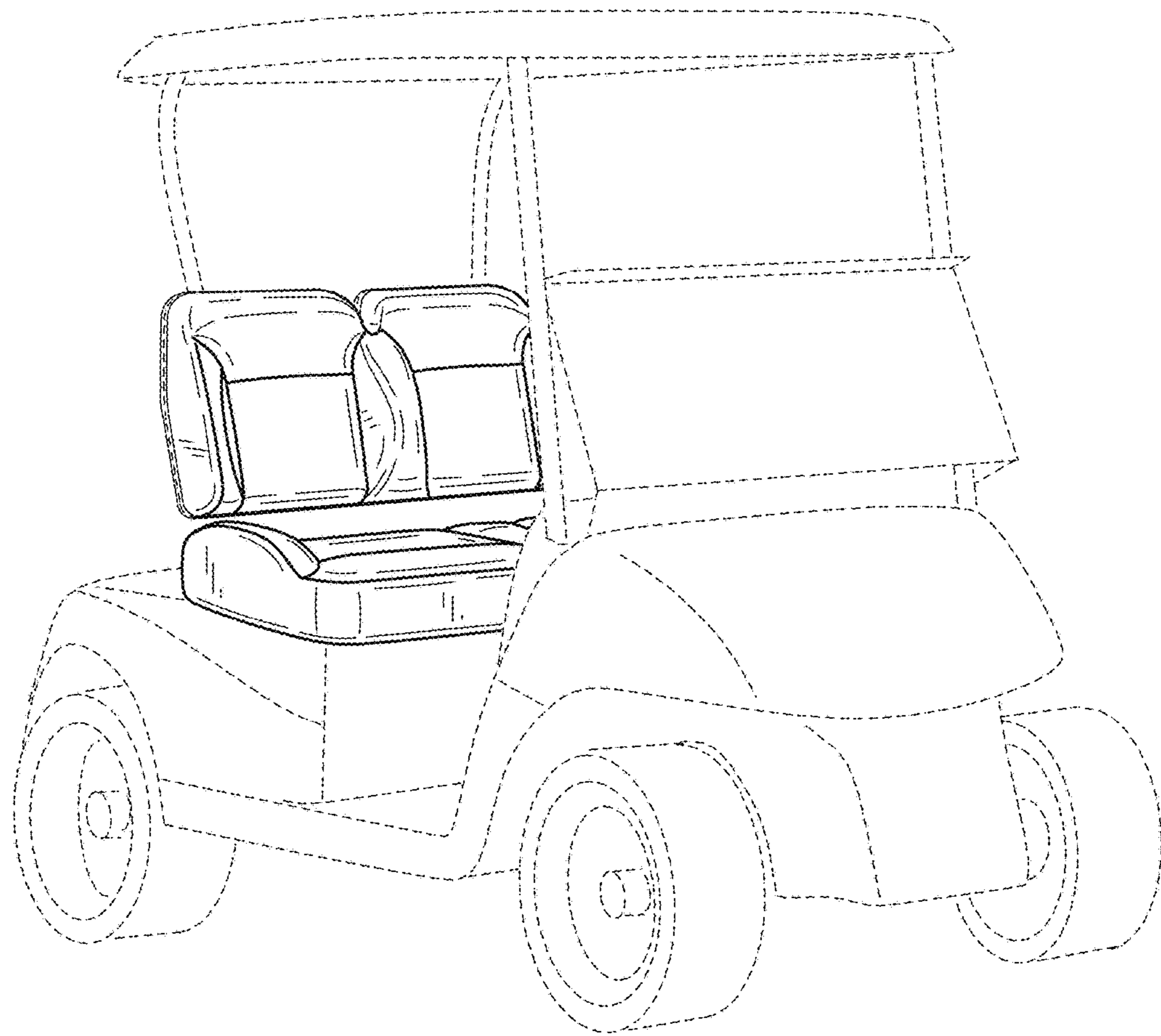

FIG. 1



FIG. 2

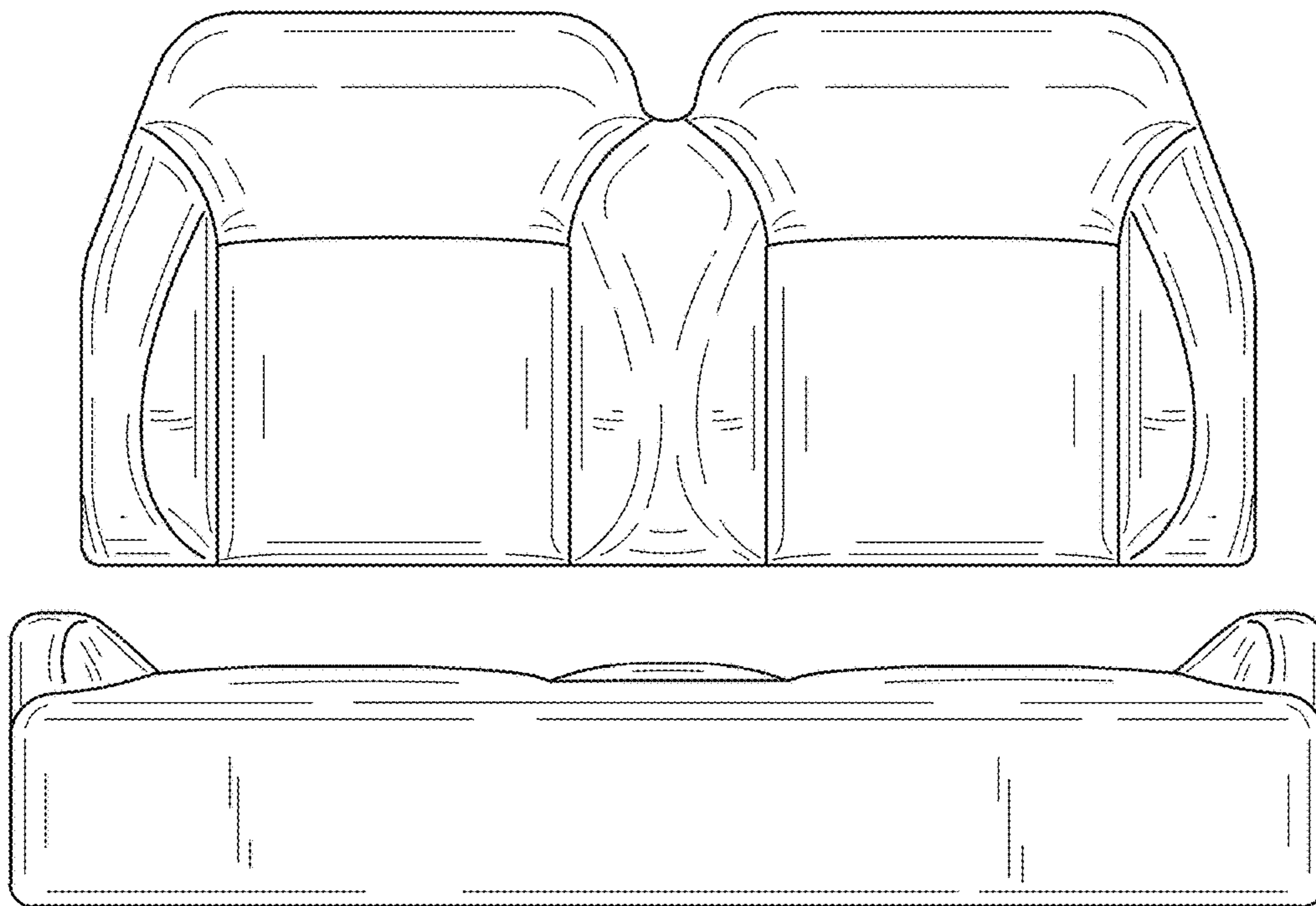

FIG. 3

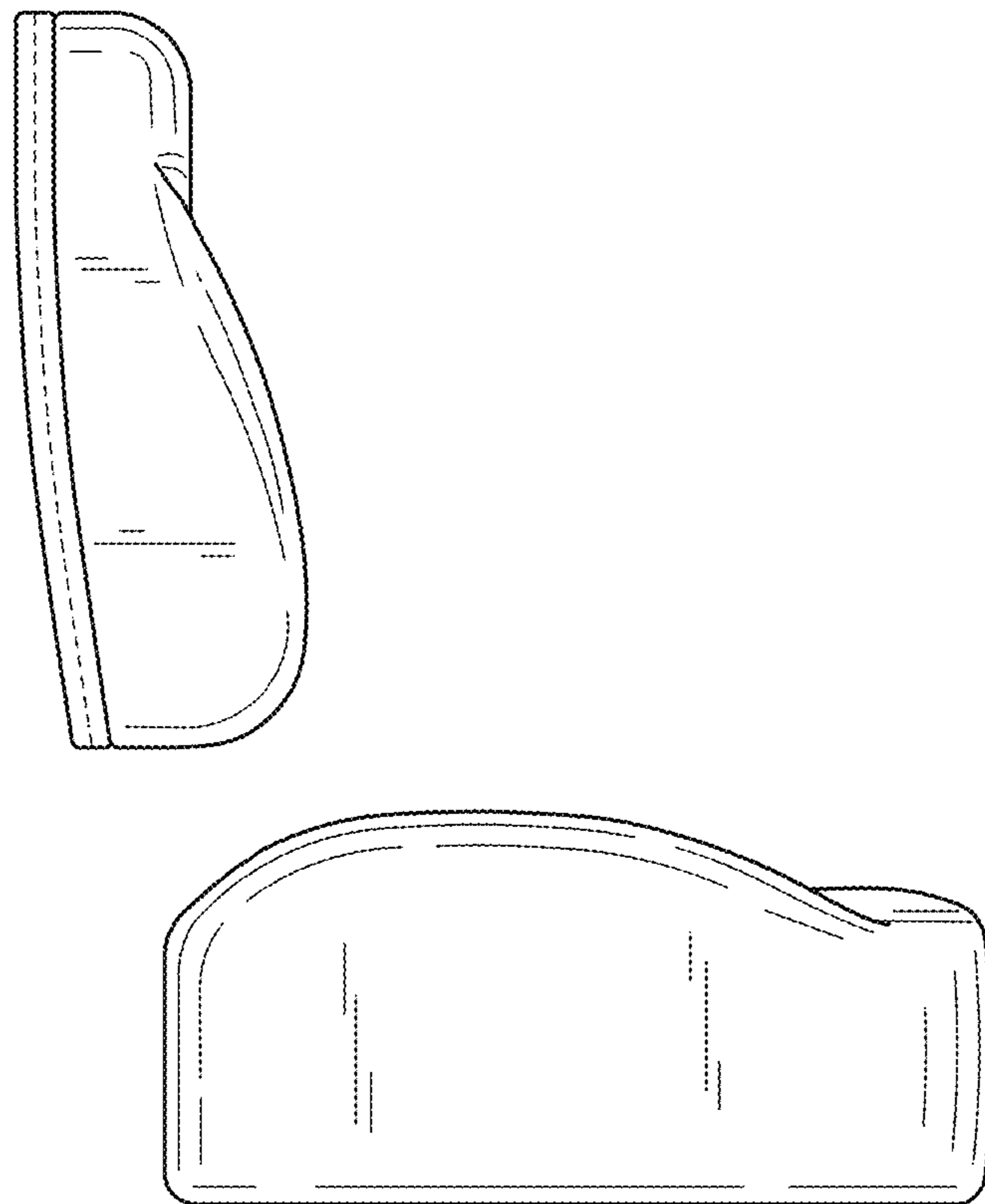

FIG. 4

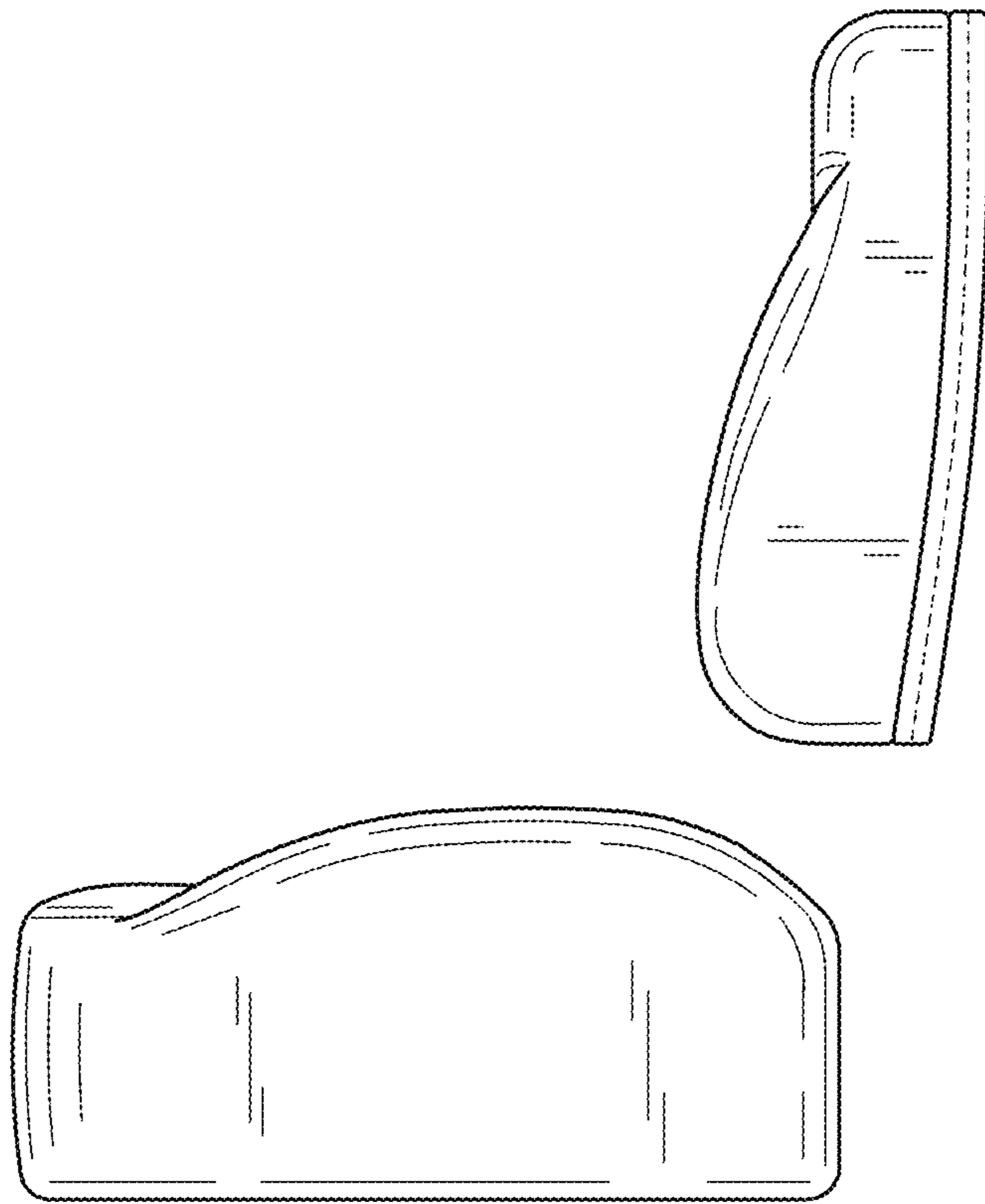

FIG. 5

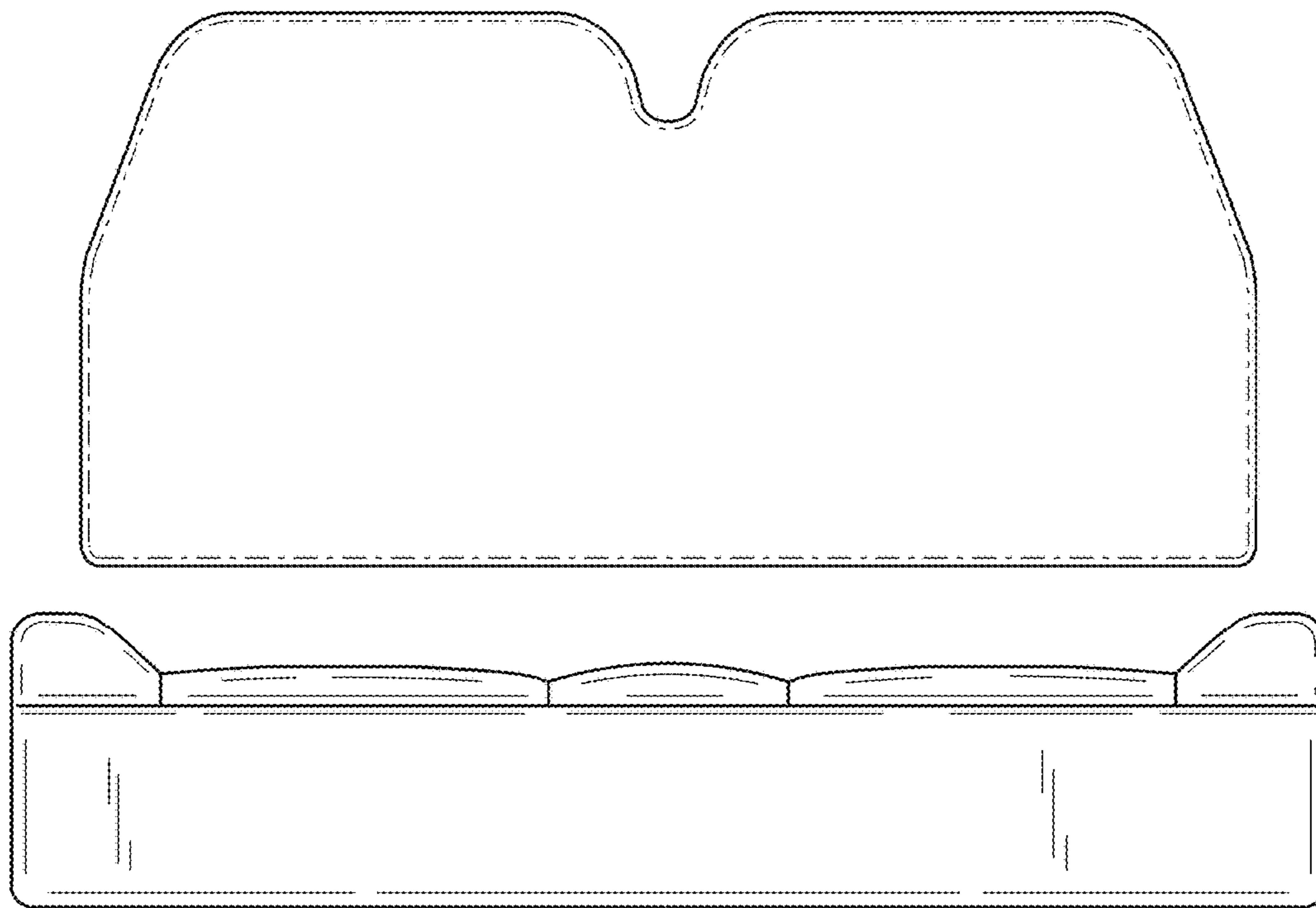

FIG. 6

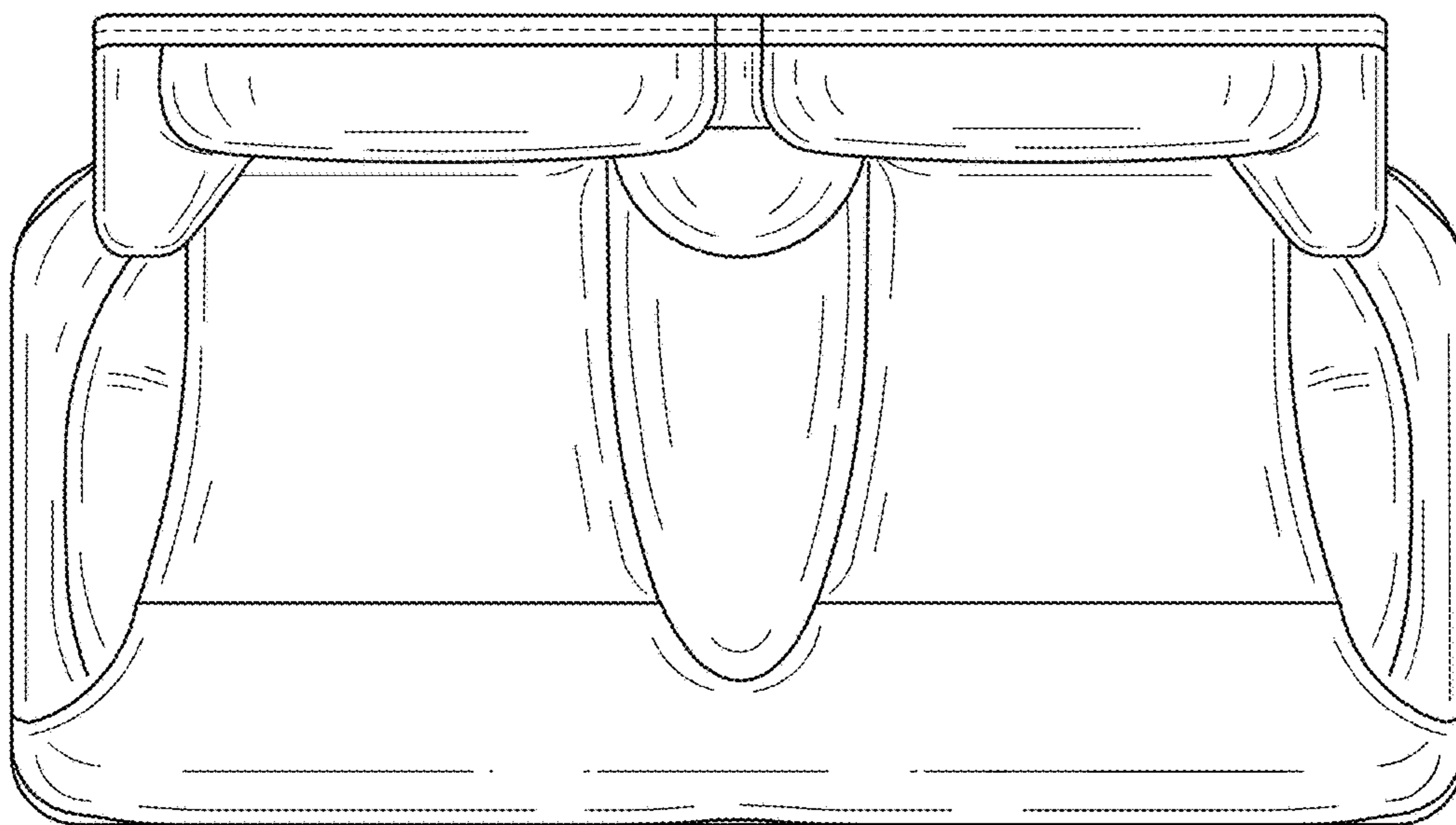

FIG. 7

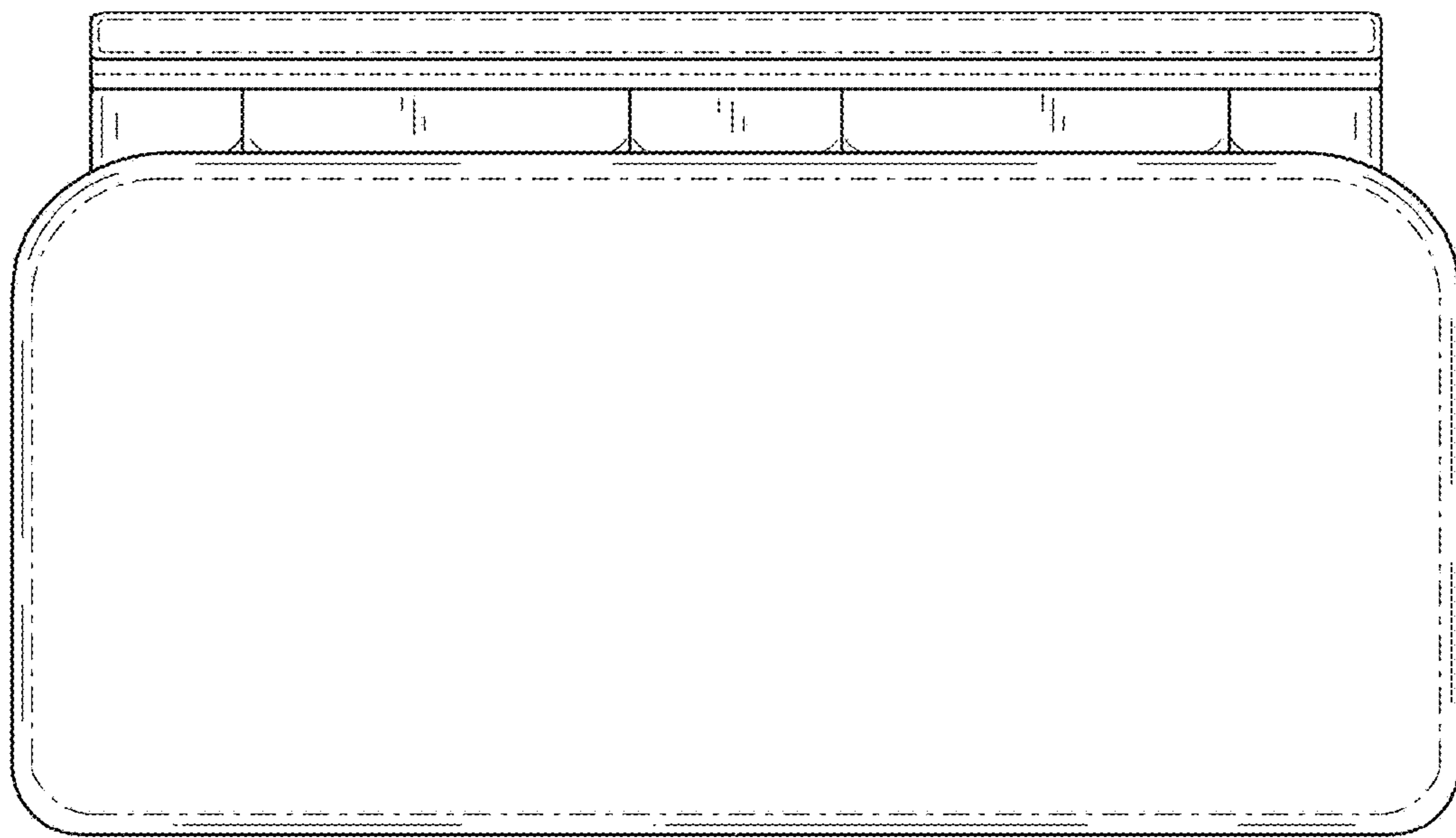

FIG. 8