

US00D812837S

(12) **United States Design Patent**
Herrick

(10) **Patent No.:** **US D812,837 S**

(45) **Date of Patent:** **** Mar. 13, 2018**

(54) **WALK-BEHIND OR RIDEABLE GOLF TROLLEY**

D694,669 S * 12/2013 Schwenk D12/1
D702,010 S * 4/2014 Wang D34/15
D753,021 S * 4/2016 Allen D12/16

(71) Applicant: **Michael Herrick**, Lincoln (GB)

* cited by examiner

(72) Inventor: **Michael Herrick**, Lincoln (GB)

Primary Examiner — Cynthia Ramirez

(**) Term: **15 Years**

(74) *Attorney, Agent, or Firm* — Bernhard P. Molldrem, Jr

(21) Appl. No.: **29/561,924**

(57) **CLAIM**

(22) Filed: **Apr. 21, 2016**

The ornamental design for a walk-behind or rideable golf trolley, as shown and described.

(30) **Foreign Application Priority Data**

DESCRIPTION

Oct. 21, 2015 (GB) GB5000186

(51) **LOC (11) Cl.** **12-13**

(52) **U.S. Cl.**
USPC **D34/15**

(58) **Field of Classification Search**
USPC D34/15; D12/16, 14; 224/274;
180/DIG. 5, DIG. 6, 19.3, 19.1, 215, 216,
180/907
CPC B62B 2202/404; B62B 3/02
See application file for complete search history.

FIG. 1 is a front elevational view of a walk-behind or rideable golf trolley embodying my new design, here shown in its raised or ride configuration.

FIG. 2 is a left-side elevational view thereof in the elevated or ride configuration, the right side elevation being a mirror image.

FIG. 3 is a front-left perspective view thereof in the elevated or ride configuration.

FIG. 4 is a rear-elevational view thereof in the elevated or ride configuration.

FIG. 5 is a left side elevational view thereof in the inclined or walk configuration, the right side elevation being a mirror image.

FIG. 6 is a front-left perspective view thereof in its inclined or walk configuration; and,

FIG. 7 is a rear-left perspective view thereof.

The broken-line showing of wheels is included for the purpose of illustrating portions of the walk-behind or rideable golf trolley, and forms no part of the claimed design.

(56) **References Cited**

U.S. PATENT DOCUMENTS

D209,391 S * 11/1967 Allen D12/110
3,777,836 A * 12/1973 Riza B62D 49/0671
180/213
D596,821 S * 7/2009 Reimers D34/15
D647,679 S * 10/2011 Liao D34/15

1 Claim, 7 Drawing Sheets

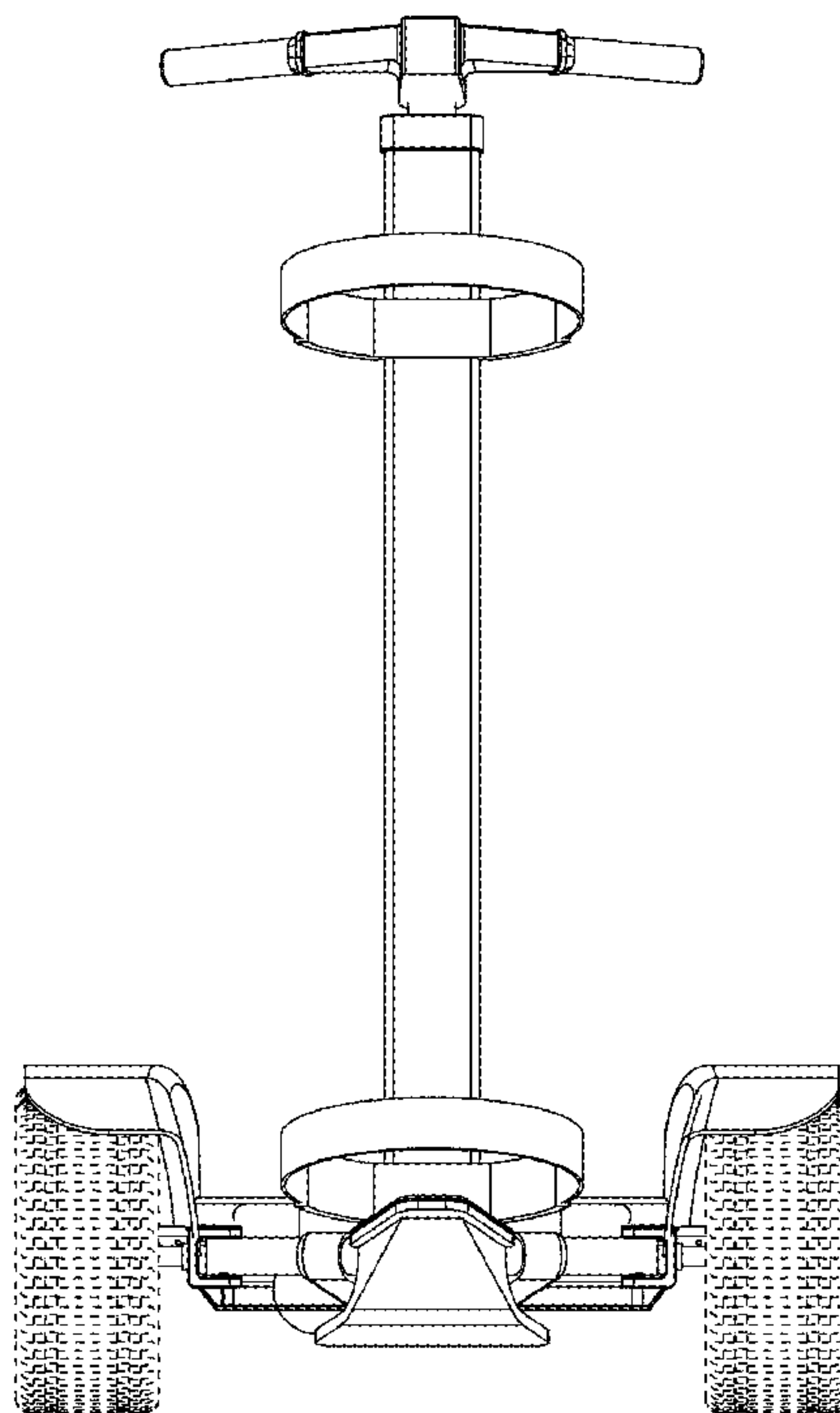

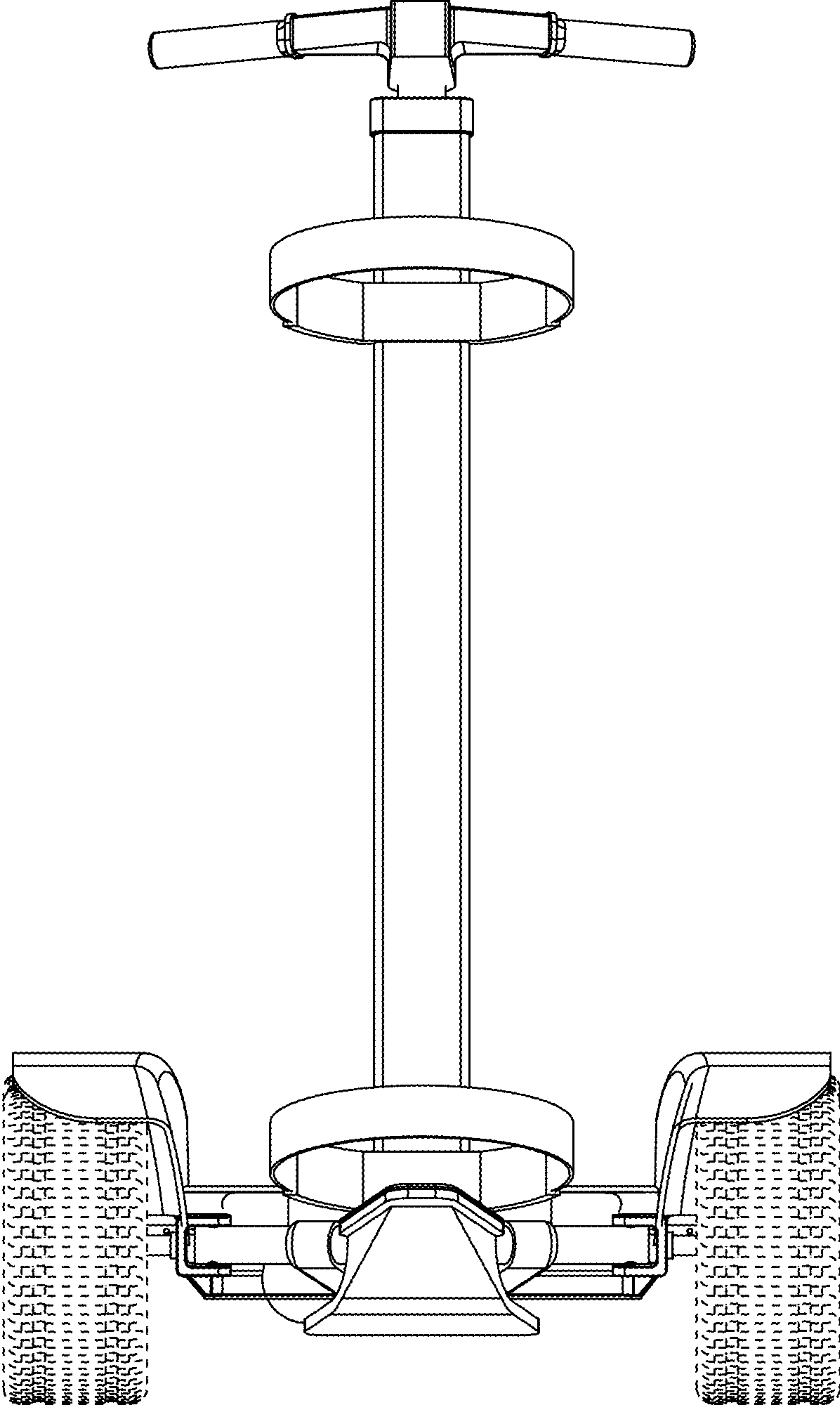

FIG. 1

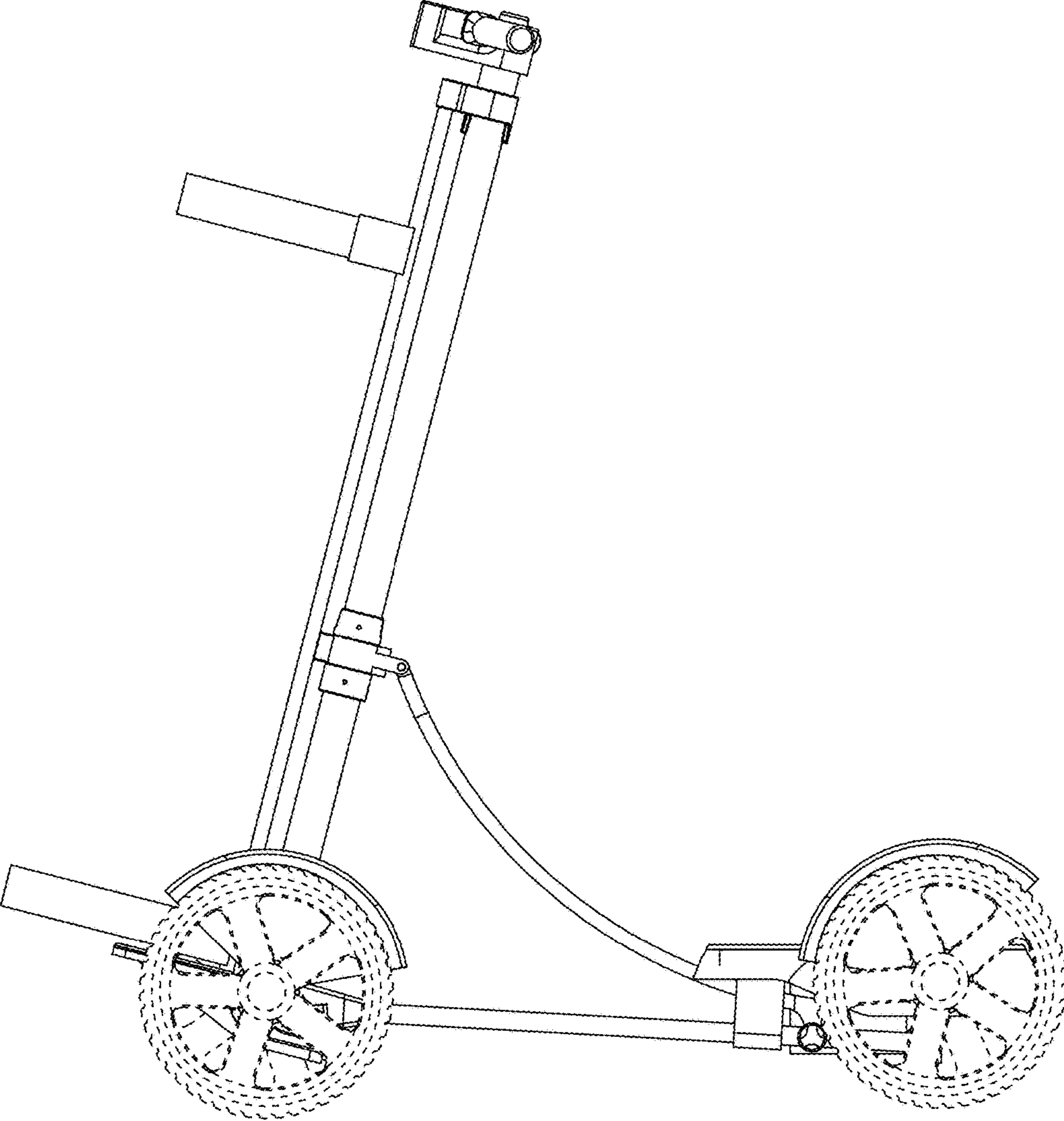

FIG. 2

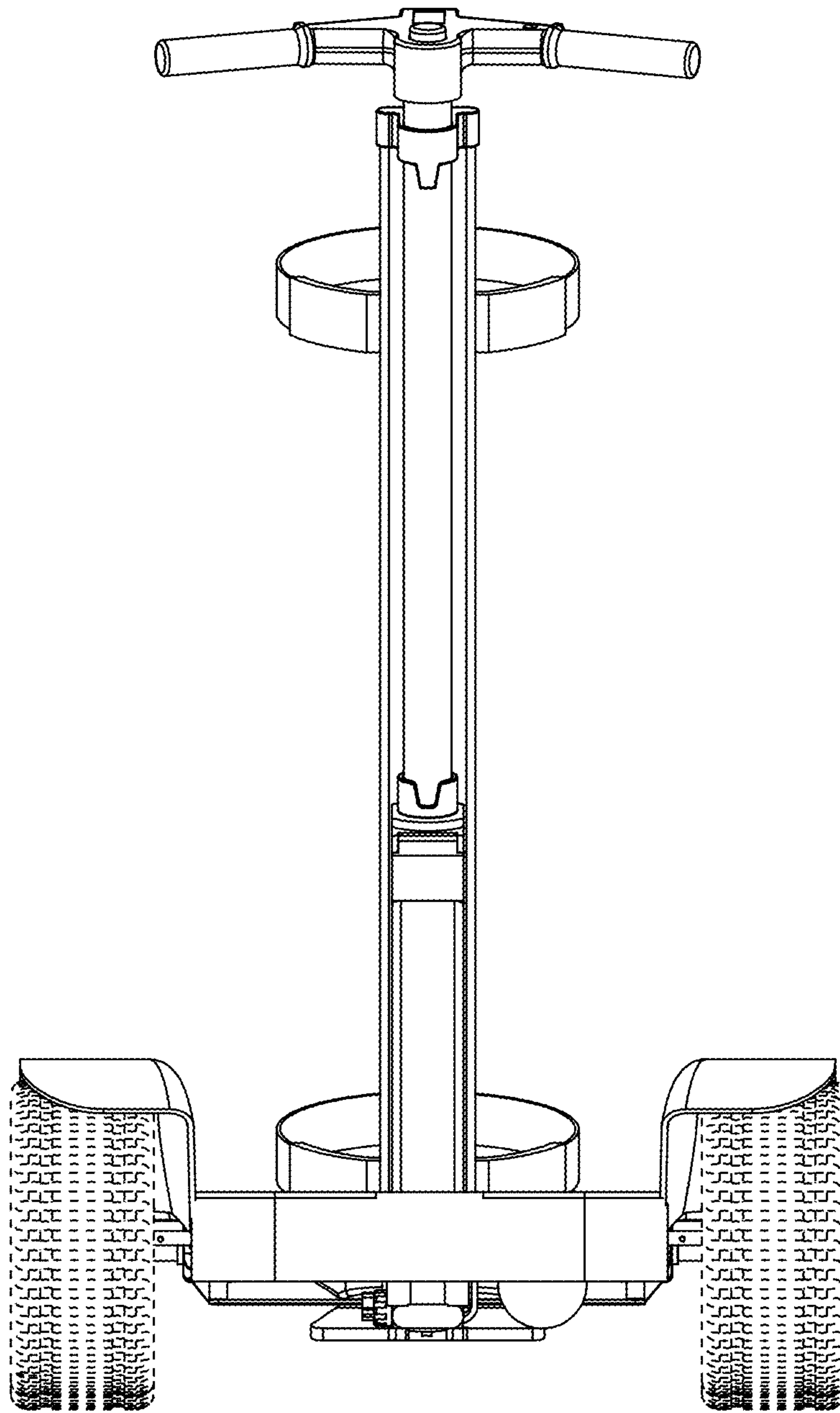

FIG. 3

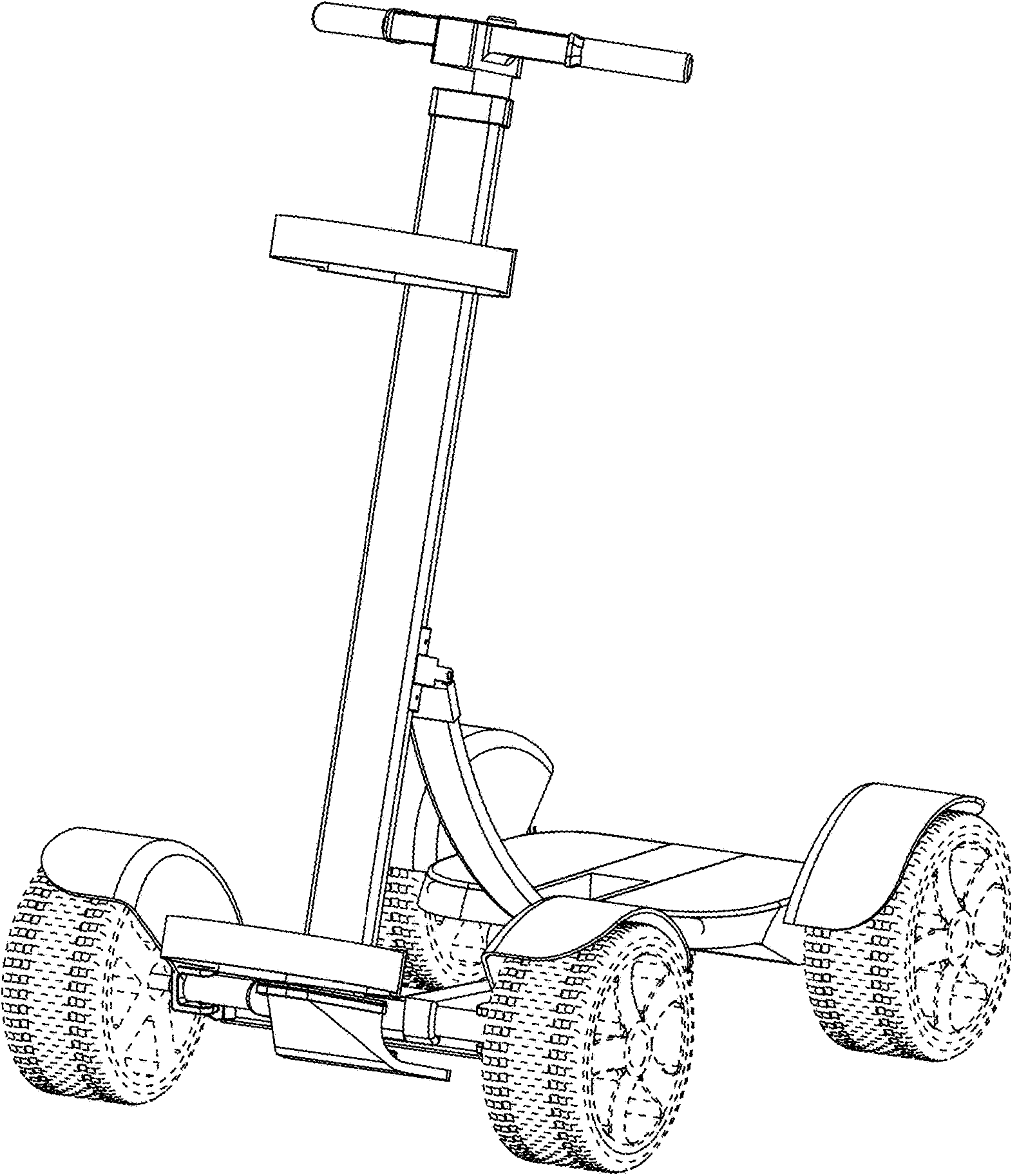

FIG. 4

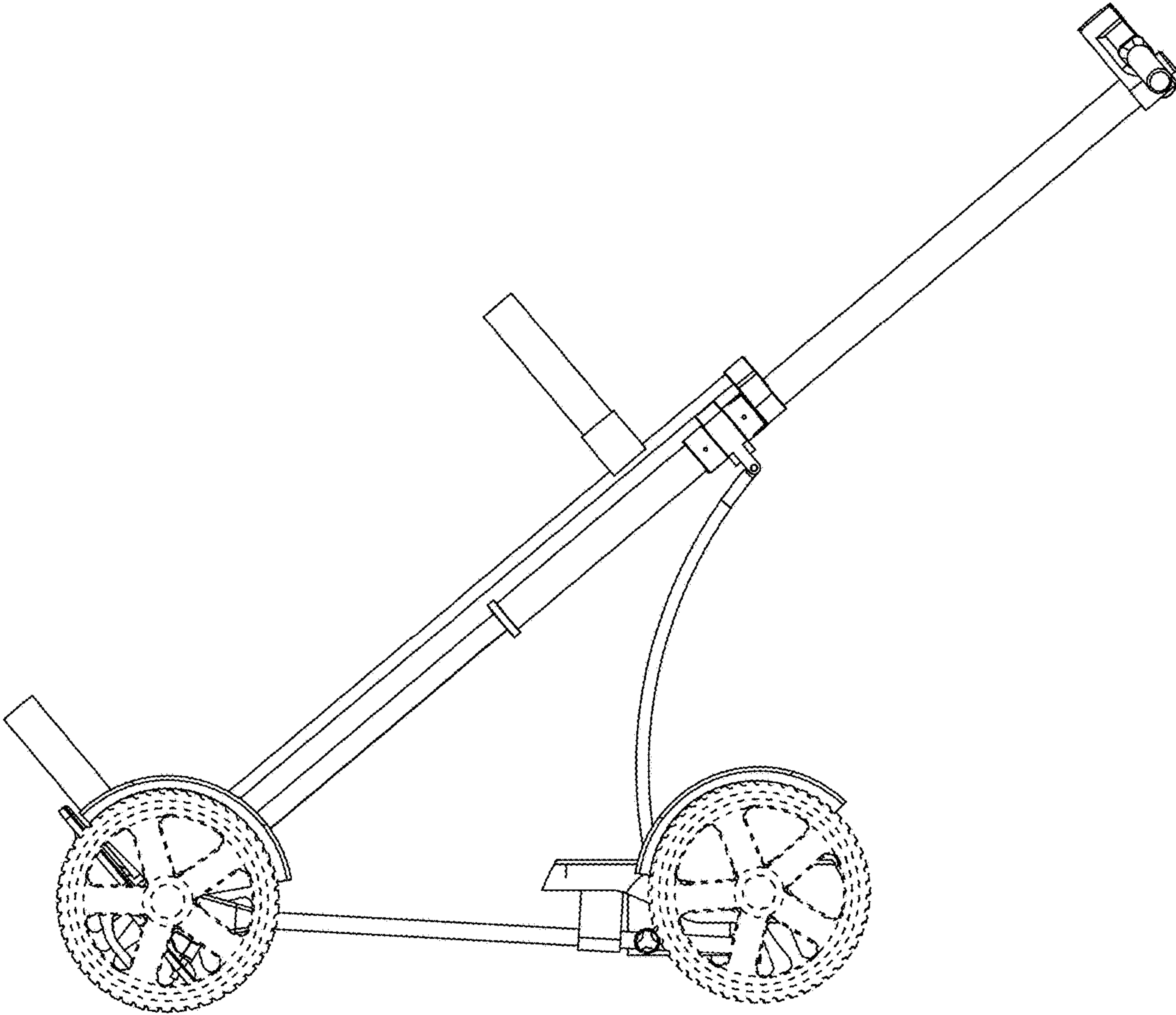

FIG. 5

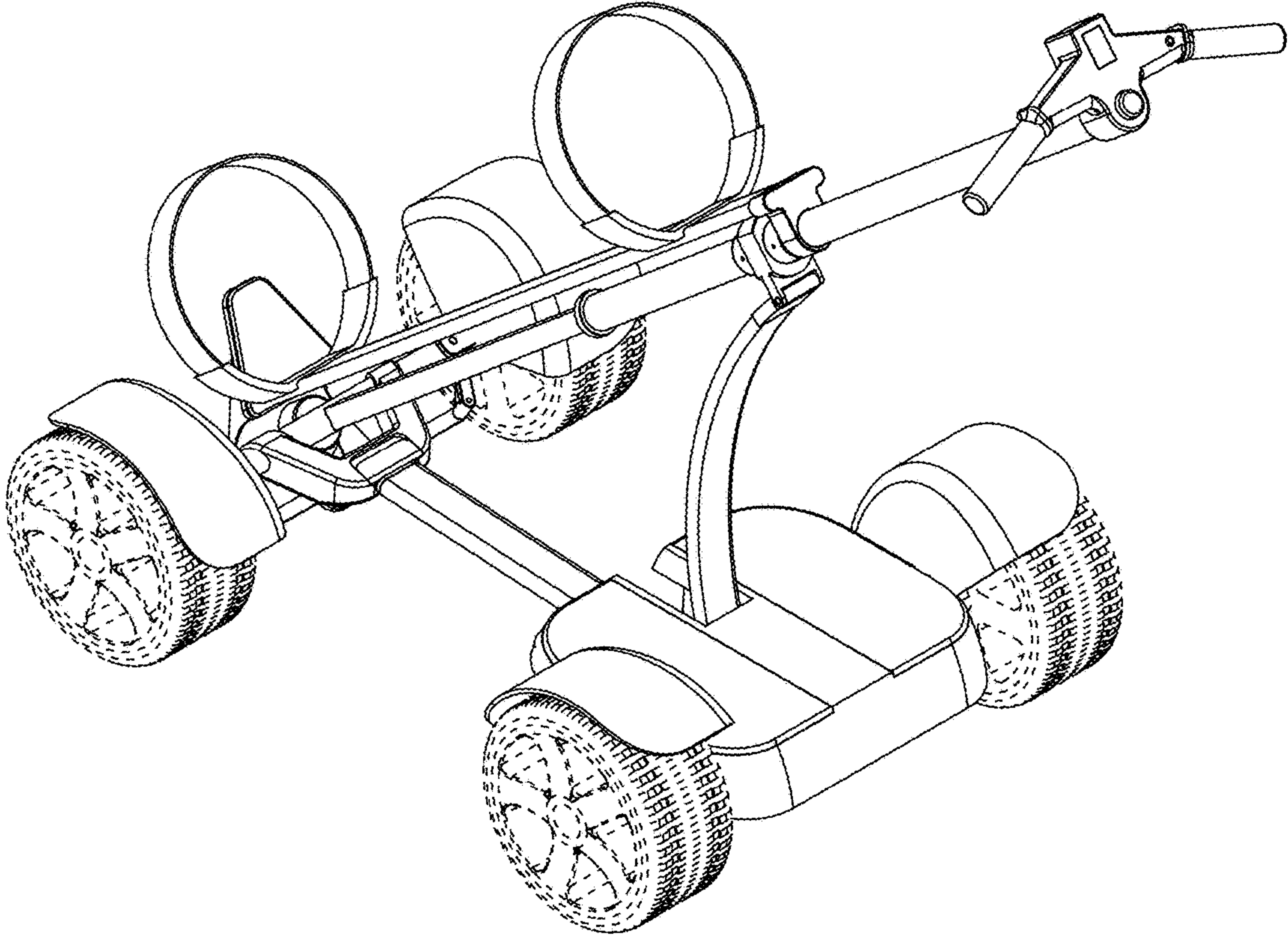

FIG. 6

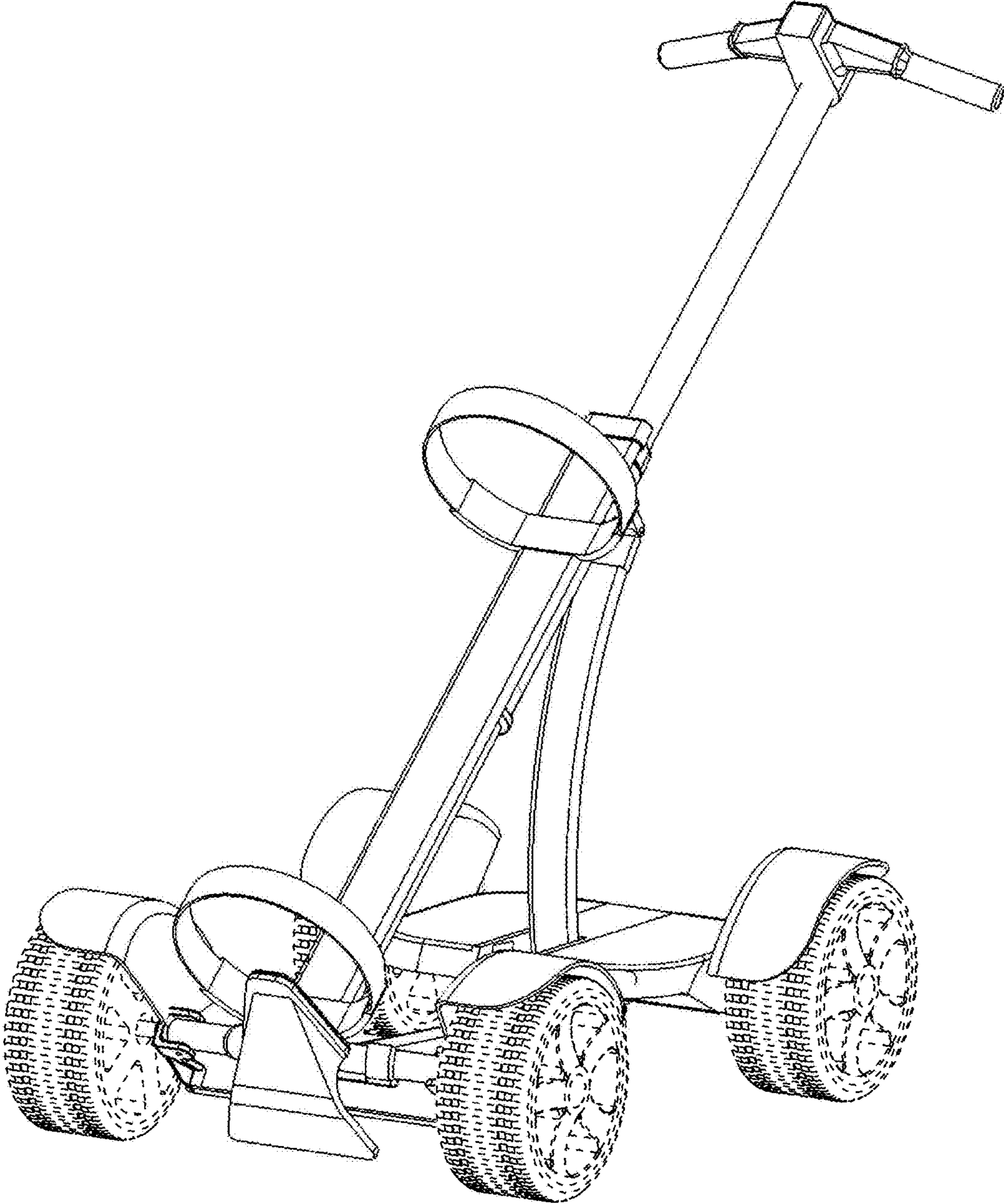

FIG. 7