



US00D812696S

(12) **United States Design Patent** (10) **Patent No.:** **US D812,696 S**
Simms (45) **Date of Patent:** **** Mar. 13, 2018**

- (54) **COMBINED PLUSH PUPPY AND CHILD'S BLANKET**
- (71) Applicant: **Simms/Mann Institute for Education and Community Development**, Beverly Hills, CA (US)
- (72) Inventor: **Victoria M. Simms**, Beverly Hills, CA (US)
- (73) Assignee: **Simms/Mann Institute for Education and Community Development**, Beverly Hills, CA (US)
- (**) Term: **15 Years**
- (21) Appl. No.: **29/581,351**
- (22) Filed: **Oct. 18, 2016**
- (51) **LOC (11) Cl.** **21-01**
- (52) **U.S. Cl.**
USPC **D21/659**; D21/611
- (58) **Field of Classification Search**
USPC D6/598; D11/158, 162; D21/576-596, D21/604-605, 610-613, 616, 617-618, D21/655-656, 658-661; 446/368-369, 446/376, 428, 487; 180/8.6
CPC . A63H 3/00; A63H 3/02; A63H 3/003; A63H 3/04; A63H 3/16; A63H 3/28; A63H 33/00; A63H 7/06; A63H 11/00; A63H 11/10; A63H 11/20; A63H 13/00
See application file for complete search history.

- D408,671 S * 4/1999 Bear D21/611
- D423,065 S * 4/2000 Wong D21/611
- D426,414 S * 6/2000 Reithmeier D21/611
- D434,261 S * 11/2000 Rosenstadt D21/611
- D453,419 S * 2/2002 Kaplan D21/611
- 6,421,852 B1 * 7/2002 Shao A63H 3/005
446/73
- 6,427,265 B1 8/2002 Dix
- 6,427,267 B1 * 8/2002 Turner A63H 3/02
446/369

(Continued)

OTHER PUBLICATIONS

Zanie Fleece Snuggle Puppy Blanket, dated Dec. 4, 2012. <http://irresistiblepets.net/2012/12/irresistible-gift-ideas-for-new-puppies/>.*

(Continued)

Primary Examiner — Sandra L Morris
(74) *Attorney, Agent, or Firm* — Dunlap Coddling, P.C.

(57) **CLAIM**

The ornamental design for a combined plush puppy and child's blanket, as shown and described.

DESCRIPTION

FIG. 1 is a perspective view of a combined plush puppy and child's blanket showing my new design.
FIG. 2 is a front elevational view thereof.
FIG. 3 is a rear elevational view thereof.
FIG. 4 is a right side elevational view thereof.
FIG. 5 is a left side elevational view thereof.
FIG. 6 is a top plan view thereof.
FIG. 7 is a bottom plan view thereof; and,
FIG. 8 is perspective view thereof showing a flap on the child's blanket in an open position.
The broken lines shown in FIGS. 1-8 are for purposes of illustrating environment only and form no part of the claimed design.

1 Claim, 6 Drawing Sheets

- (56) **References Cited**
U.S. PATENT DOCUMENTS
4,204,362 A 5/1980 Fournier
4,590,633 A * 5/1986 Pickens A63H 3/02
446/369
D318,503 S * 7/1991 Danova D21/605
D327,361 S * 6/1992 Rush D21/613
5,344,355 A 9/1994 Silverstein
D385,453 S * 10/1997 Agopian D6/598

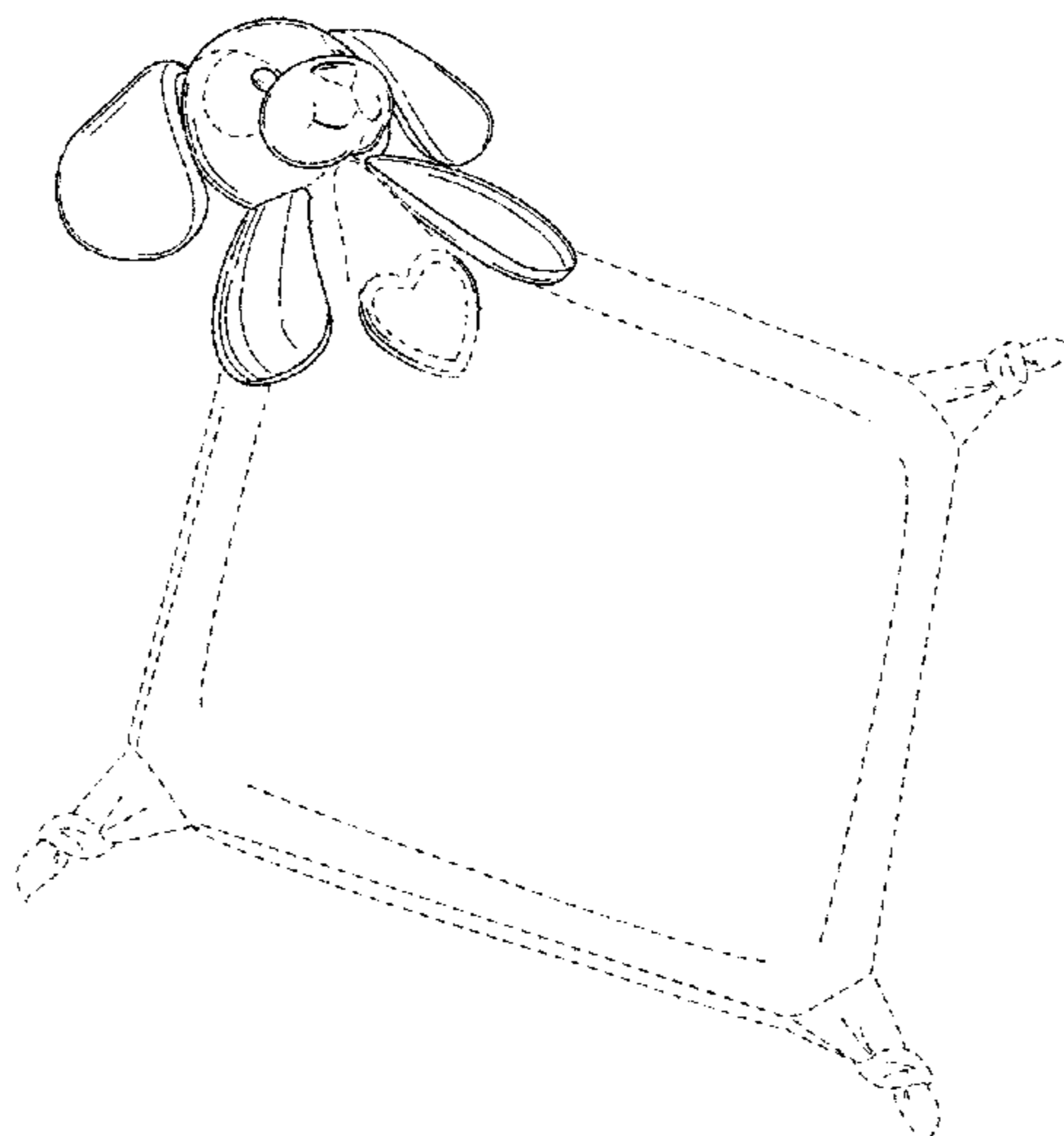

(56)

References Cited

U.S. PATENT DOCUMENTS

| | | | | |
|-------------------|---------|--------------|-------|----------------------|
| D525,321 S * | 7/2006 | Huetteman | | D21/612 |
| D565,127 S * | 3/2008 | Walwyn-Jones | | D21/613 |
| D672,098 S * | 12/2012 | Byrne | | D21/659 |
| D688,331 S * | 8/2013 | Dalton | | D21/576 |
| 8,864,544 B2 * | 10/2014 | Anderman | | A63H 3/003 2/75 |
| 8,869,325 B2 * | 10/2014 | Ng | | A47G 9/0223 5/485 |
| 2002/0144351 A1 * | 10/2002 | Fujii | | A63H 3/003 D6/598 |
| 2010/0317252 A1 | 12/2010 | Raimondi | | |

OTHER PUBLICATIONS

- Center on the Developing Child, Harvard University. *Brain Architecture*. 2017. Retrieved from the Internet: <http://developingchild.harvard.edu/science/key-concepts/brain-architecture/>.
- National Scientific Council on the Developing Child. *The Timing and Quality of Early Experiences Combine to Shape Brain Architecture: Working Paper #5*. Dec. 2007. Retrieved from the internet: <http://www.developingchild.net>.
- Georgetown University Center for Child and Human Development. *Infant Toddler Temperament Tool (IT)*. Retrieved from the internet: <https://www.ecmhc.org/temperament/>.
- The Center for Parenting Education. *Understanding Goodness of Fit*. 2006-2017. Retrieved from the internet: <http://centerforparentingeducation.org/library-of-articles/child-development/understanding-goodness-of-fit/>.
- Gunderson, E.A. et al. *Parent Praise to 1-to 3-Year-Olds Predicts Children's Motivational Frameworks 5 Years Later*. *Child Development*. vol. 84, Issue 5, pp. 1526-1541, Feb. 11, 2013. Retrieved from the internet: <http://onlinelibrary.wiley.com/doi/10.1111/cdev.12064/abstract?sessionid=072A39166D5776090430BEB9799915AA.f03t03>.
- The Pacella Parent Child Center: Helping You Grow as a Parent. *Limit Setting/Discipline*. 2010-2015. Retrieved from the internet: <http://www.theparentchildcenter.org/parenting-articles/limit-setting-discipline>.
- Ginsburg, Kenneth R. *The Importance of Play in Promoting Healthy Child Development and Maintaining Strong Parent-Child Bonds*. *Pediatrics*. vol. 119, No. 1, Jan. 2007. Retrieved from the internet: <http://pediatrics.aappublications.org/content/pediatrics/119/1/182.full.pdf>.
- Lafayette College. *New Study of Toddlers Sheds Light on Value of Facetime Video Chat as Meaningful Interaction*. *Science Daily*. Jul. 15, 2016. Retrieved from the internet: <https://www.sciencedaily.com/releases/2016/160715115023.htm>.
- United Nations Human Rights Office of the High Commissioner. *Convention on the Rights of the Child*. Sep. 2, 1990. Retrieved from the internet: <http://www.ohchr.org/EN/ProfessionalInterest/Pages/CRC.aspx>.
- Zhao, T.C. et al. *Musical Intervention Enhances Infants' Neural Processing of Temporal Structure in Music and Speech*. *Proceedings of the National Academy of Sciences*, vol. 113 No. 19, pp. 5212-5217, Mar. 17, 2016. Retrieved from the internet: <http://www.pnas.org/content/113/19/5212.full>.
- What to Expect. *Daycare 101: How to Choose the Best Facility for Your Family*. Nov. 30, 2015. Retrieved from the internet: <http://www.whattoexpect.com/first-year/daycare>.
- Feldman, Ruth. *Bio-behavioral Synchrony: A Model for Integrating Biological and Microsocial Behavioral Processes in the Study of Parenting*. *Parenting: Science and Practice*. Special Issue: The Arc of Parenting from Epigenomics to Ethics, Psychology Press: New York., vol. 12 No. 2-3, pp. 93-267, Apr. 2012.
- Winnicott, D.W. *Transitional Objects and Transitional Phenomena—A Study of the First Not-Me Possession*. *The International Journal of Psychoanalysis*. vol. 34, pp. 89-97. 1953. Retrieved from the internet: <https://nonoedipal.files.wordpress.com/2009/09/transitional-objects-and-transitional-phenomena-28094a-study-of-the-first-not-me-possession.pdf>.
- Winnicott, D.W. *Transitional Objects and Transitional Phenomena*. *The International Journal of Psycho-Analysis*. vol. 34, Part 2, 1953.
- Mahler, M.S. "A Study of the Separation-Individuation Process—and its Possible Application to Borderline Phenomena in the Psychoanalytic Situation." *Psychoanalytic Study of the Child*, 1971.
- Kopp, Claire B. *Antecedents of Self-Regulation: A Developmental Perspective*. *Developmental Psychology*. vol. 18, No. 2, pp. 199-214, 1982.
- Tronick, Ed et al. *Infants' Meaning-Making and the Development of Mental Health Problems*. *American Psychologist*. vol. 66, No. 2, pp. 107-119, Feb.-Mar. 2011.
- Spagnola Ph.D., Mary et al. *Family Routines and Rituals: A Context for Development in the Lives of Young Children*. *Infants & Young Children*, vol. 20, No. 4, pp. 284-299, 2007.
- Winnicott, D.W. *The Maturation Processes and the Facilitating Environment*. New York: Second Printing, pp. 30, 40-41, 48-49, 50-52, 54-55, 70-72, 84-89, 109-114, 126-128, 141, 150, 166-167, 179-185, and 254-259.1966. Print.
- Lewis, Michael et al. *Handbook of Emotions: Second Edition*. New York: The Guilford Press, pp. 72, 96-97, 148, 210-212, 275-278, 387-389, 655-656 and 660-661, 2000. Print.
- Levine Ph.D., Madeline. *The Price of Privilege*. New York: Harper Collins Publishers, 74, 79, 81-82, 86-87, 134-136 and 203-204, 2006. Print.
- Brazelton, T. Berry. *Infants and Mothers*. New York: Dell Publishing Co., Inc., pp. 1-29, 121, 140, 166, 191-193, 210, 218-219, 225, 261-262 and 270, 1969. Print.
- Goleman, Daniel. *Social Intelligence: The New Science of Human Relationships*. New York: Bantam Dell, pp. 162-167, 182-184 and 193-197, Oct. 2006. Print.
- Bowlby, John. *Attachment and Loss*: vol. 1, Attachment. New York: Basic Books, Inc., pp. 3, 6-7, 11-12, 27-34, 51-53, 128, 196-209, 218-223, 225, 240, 244, 256 and 348-349, 1969. Print.
- Stern, Daniel N. *The Interpersonal World of the Infant*. New York: Basic Books, Inc., pp. 25, 114-119, 137 and 240-414, 1973. Print.
- Kaplan Ph.D., Louise J. *Oneness and Separateness: From Infant to Individual*. New York: Simon and Schuster, pp. 15-19, 21-23, 25-39, 50-51, 118-119, 121-126, 153-156, 171, 176-181 and 194, 1978. Print.
- Thomas, Alexander et al. *Temperament and Development*. New York: Brunner/Mazel Inc., pp. 8-15, 1977. Print.
- Allard, L.T. and Hunter, A. *Understanding Temperament in Infants and Toddlers*. Oct. 2010. Retrieved from the internet: <http://csefel.vanderbilt.edu/resources/wwb/wwb23.html>.
- Fonagy, P. *Attachment Theory and Psychoanalysis*. New York: Other Press, 2001. Print.
- Cohen, L.J. *Playful Parenting*. New York: Ballantine Books, 2002. Print.
- Gold, C.M. *Keeping Your Child in Mind: Overcoming Defiance, Tantrums, and Other Everyday Behavior Problems by Seeing the World Through Your Child's Eyes*. Pennsylvania: Da Capo Press, 2011. Print.
- Gopnik, A. et al. *The Scientist in the Crib: What Early Learning Tells Us About the Mind*. New York: Harper Perennial, 2000. Print.
- Brazelton, T.B. *Infants and Mothers: Differences in Development (revised edition)*. New York: Dell, 1983. Print.
- Shanker, S. *Self-Reg: How to Help Your Child (and You) Break the Stress Cycle and Successfully Engage With Life*. New York: Penguin Press, 2016. Print.
- Porges, S.W. *The Polyvagal Theory: Neurophysiological Foundations of Emotions, Attachment, Communication, and Self Regulation*. New York: W.W. Norton and Company, 2011. Print.
- Rothbart, M.K. et al. *Chapter 9: The Development of Effortful Control*. *Developing individuality in the human brain: A tribute to Michael I. Posner*. Washington, DC: American Psychological Association, pp. 1-22, 2005. Print.
- Poarch, J.E. *The Keystone of Emotional Growth*. Indiana: Accelerated Development Inc., 1990, Print.
- Eisenberg, N. *Empathy and sympathy*. *Handbook of Emotions 2nd edition*, New York: Guilford Press, pp. 677-691, 2000, Print.

(56)

References Cited

OTHER PUBLICATIONS

Hoffman, M.L. *Empathy and Moral Development: Implications for Caring and Justice*. United Kingdom: Cambridge University Press, 2001, Print.

Runkel, H.E. *Screamfree Parenting: The Revolutionary Approach to Raising Your Kids by Keeping Your Cool*. New York: Broadway Books, 2008, Print.

Cori, J.L. *The Emotionally Absent Mother: A Guide to Self-Healing and Getting the Love You Missed*. New York: The Experiment, 2010, Print.

Golinkoff, R.M. et al. *Becoming Brilliant: What Science Tells Us About Raising Successful Children*. Washington, DC: American Psychological Association LifeTools, 2016. Print.

* cited by examiner

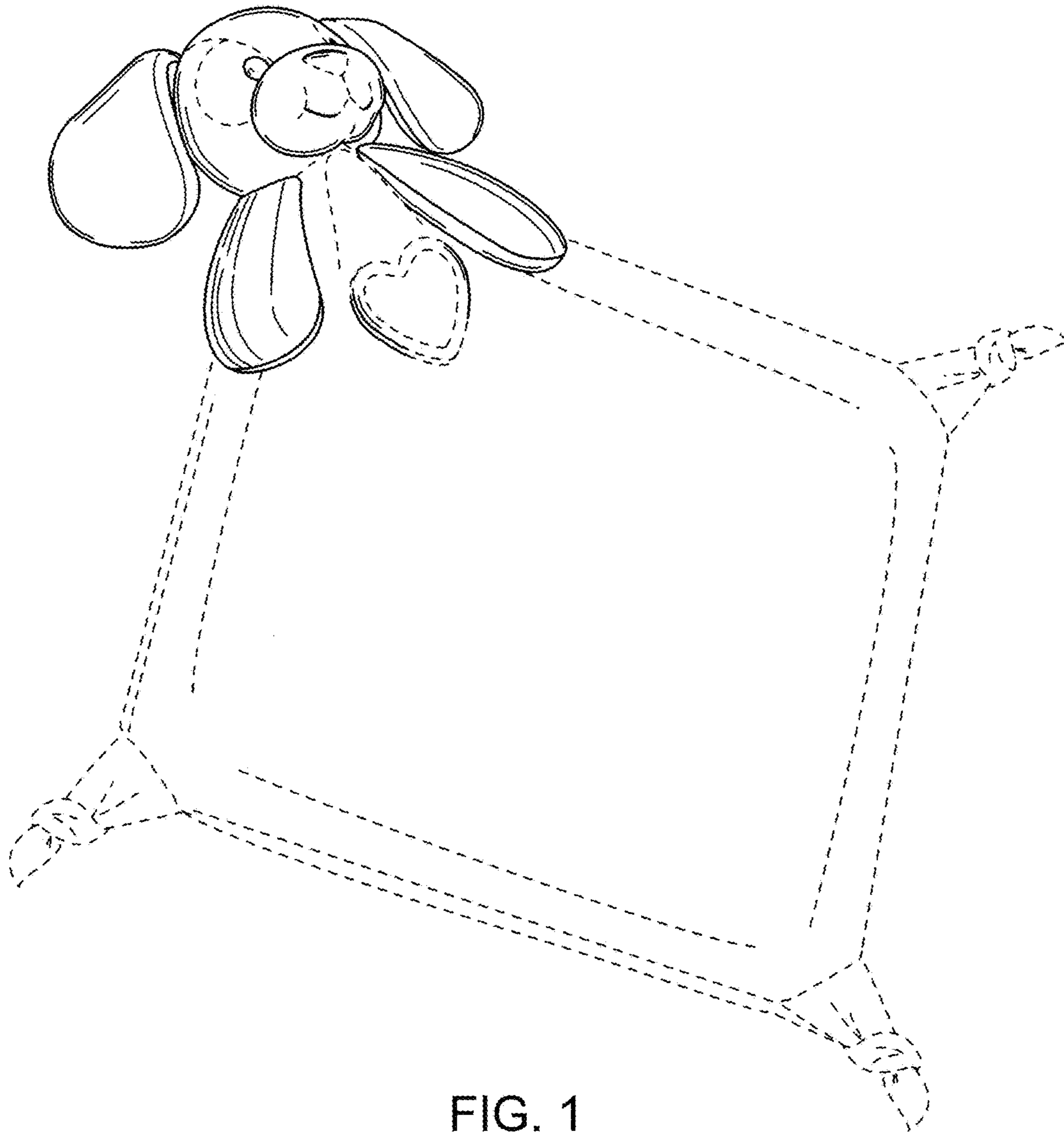

FIG. 1

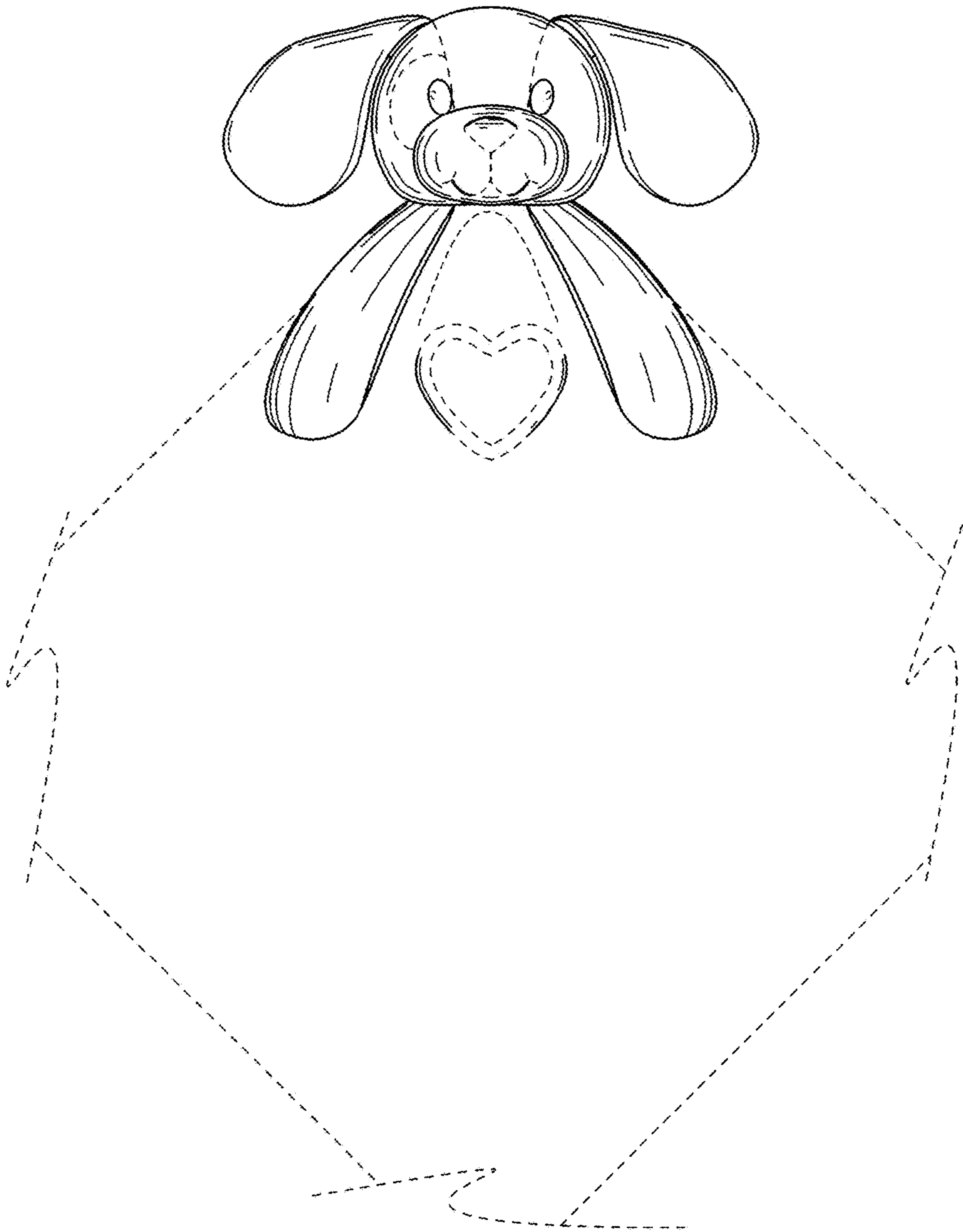

FIG. 2

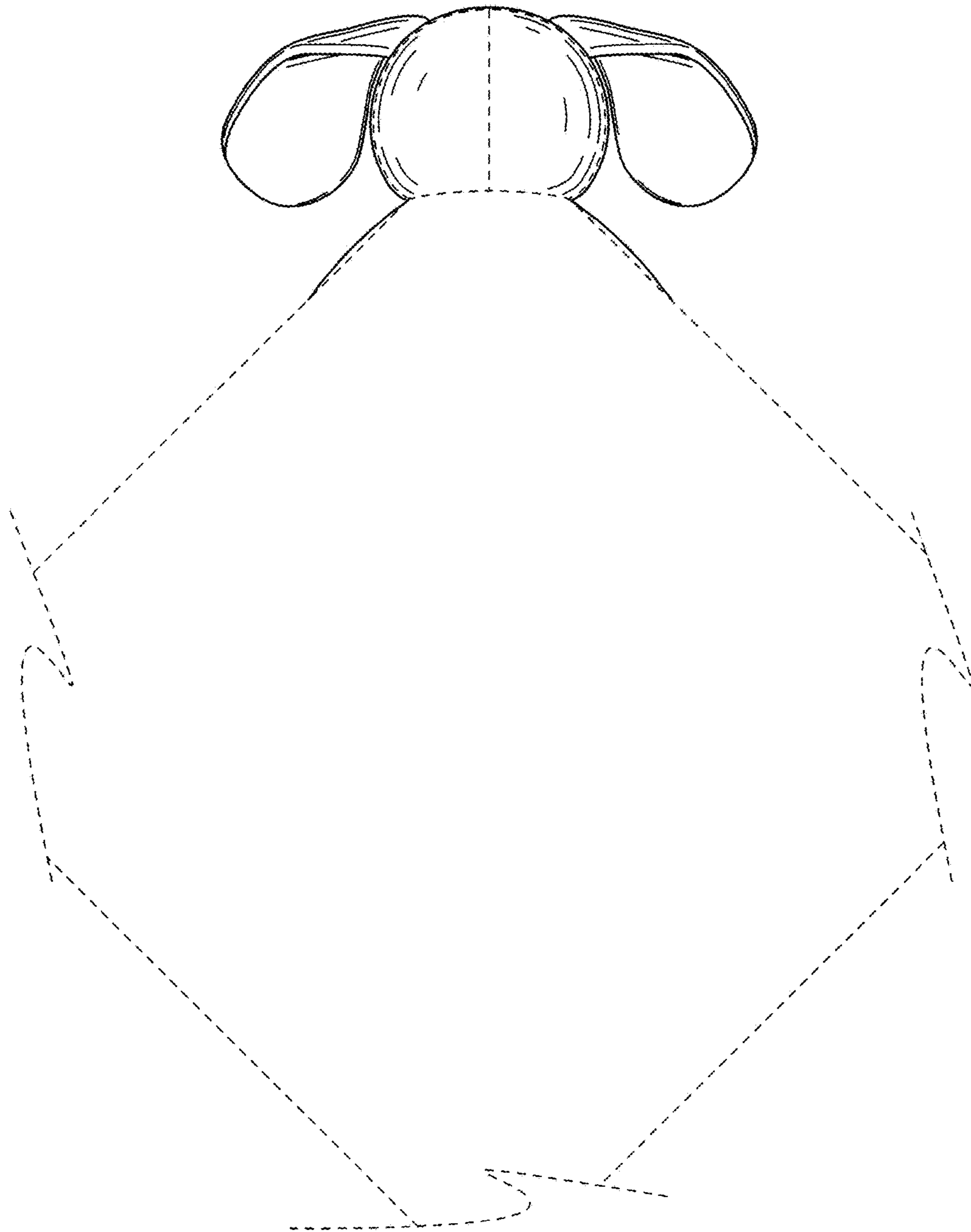

FIG. 3

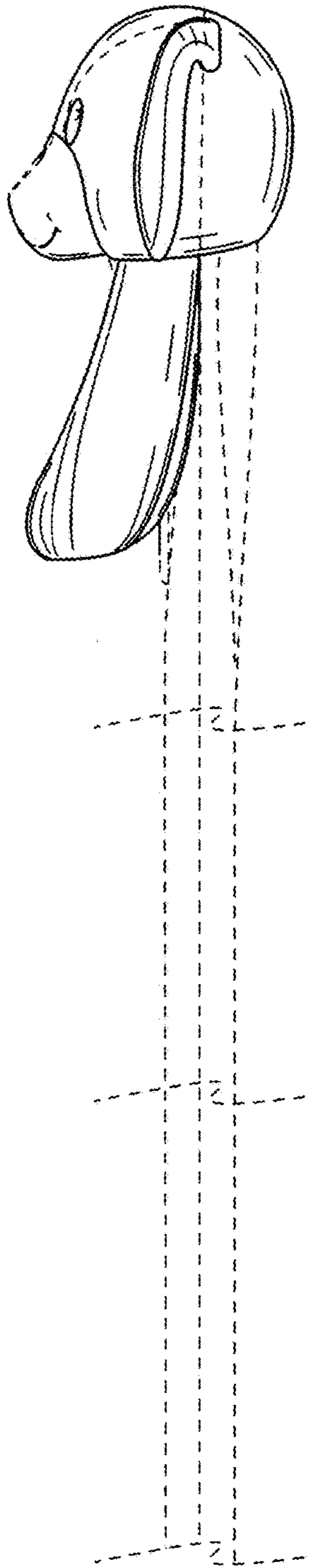

FIG. 4

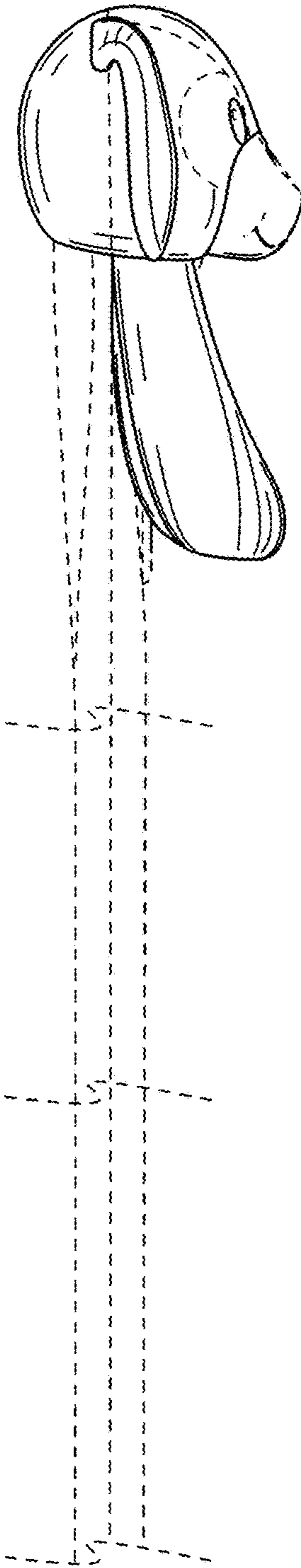

FIG. 5

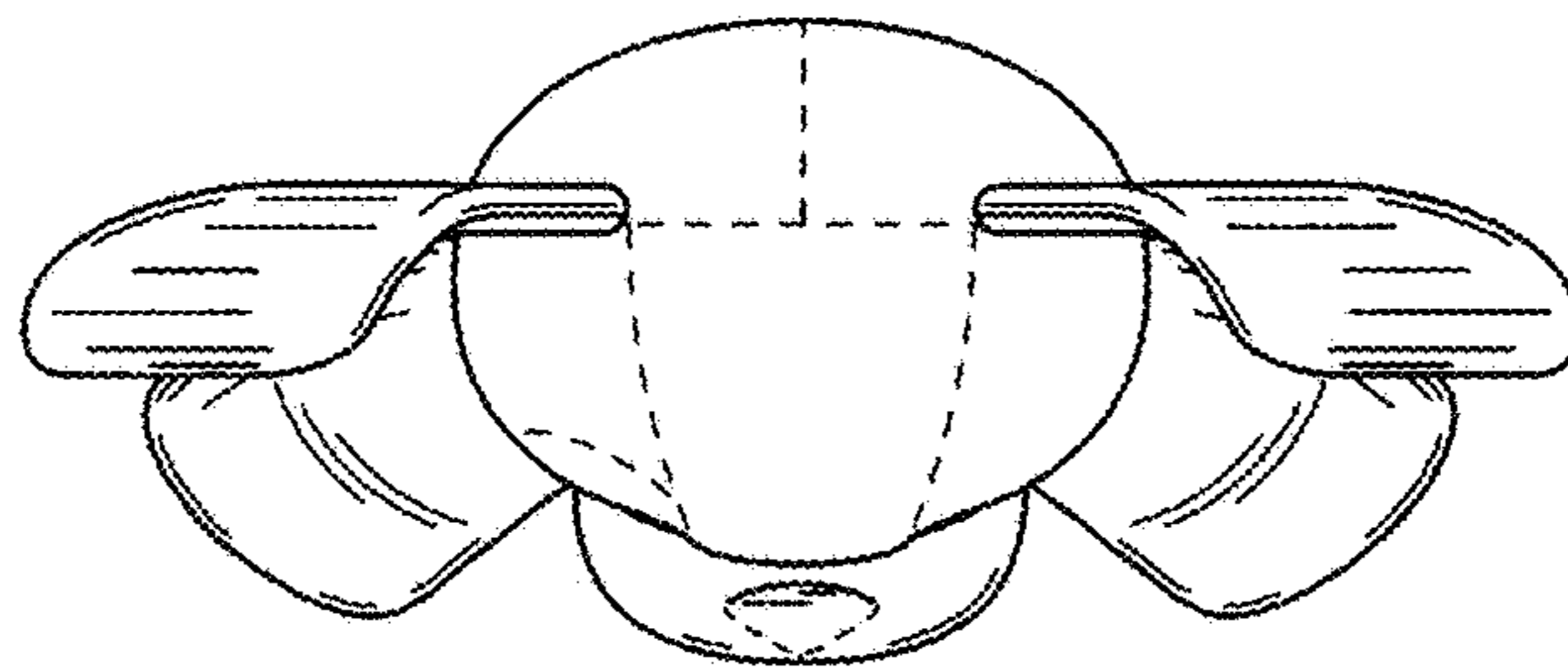

FIG. 6

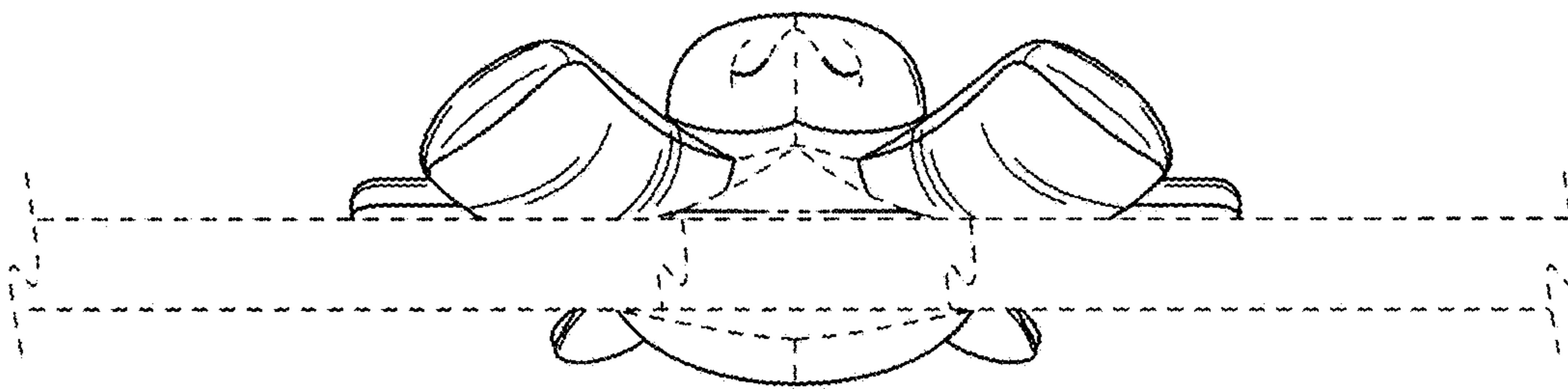

FIG. 7

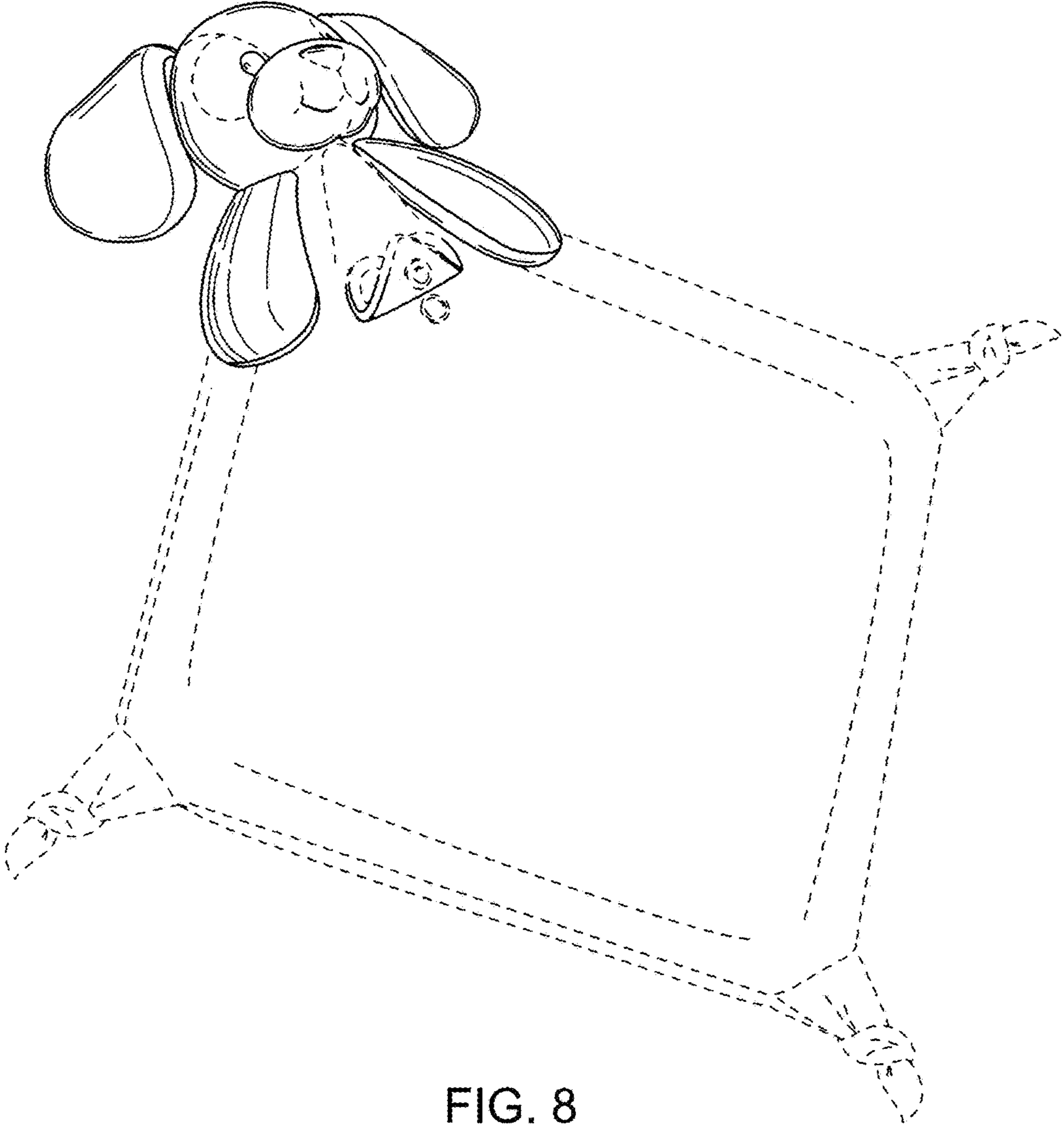

FIG. 8