



US00D812095S

(12) **United States Design Patent**  
**Kalanick et al.**

(10) **Patent No.:** **US D812,095 S**  
(45) **Date of Patent:** **\*\* Mar. 6, 2018**

(54) **DISPLAY PANEL WITH AN ANIMATED GRAPHICAL USER INTERFACE**

D669,499 S \* 10/2012 Gardner ..... D14/495  
D678,901 S \* 3/2013 Gleasman ..... D14/489  
D688,699 S \* 8/2013 Gleasman ..... D14/489  
D699,747 S \* 2/2014 Pearson ..... D14/488

(71) Applicant: **Uber Technologies, Inc.**, San Francisco, CA (US)

(Continued)

(72) Inventors: **Travis Kalanick**, San Francisco, CA (US); **Shalin Amin**, San Francisco, CA (US); **Bryant Jow**, San Francisco, CA (US); **Rogério Cerqueira Oddone**, San Francisco, CA (US); **Mirtho Prepont**, El Cerrito, CA (US)

OTHER PUBLICATIONS

Liberatore, Stacy, Do Not Adjust Your Phones, Feb 2, 2016, DailyMail.com [online], [site visited Oct. 10, 2017]. Available from Internet : <http://www.dailymail.co.uk/sciencetech/article-3428998/What-Earth-Uber-reveals-bizarre-new-logo-says-inspired-bits-atoms.html> (Year: 2016).\*

(73) Assignee: **Uber Technologies, Inc.**, San Francisco, CA (US)

*Primary Examiner* — Karen E Kearney

*Assistant Examiner* — Katherine A Holbrow

(\*\*) Term: **15 Years**

(74) *Attorney, Agent, or Firm* — Fenwick & West LLP

(21) Appl. No.: **29/553,270**

(57) **CLAIM**

We claim the ornamental design for a display panel with an animated graphical user interface, as shown and described.

(22) Filed: **Jan. 29, 2016**

(51) **LOC (11) Cl.** ..... **14-04**

(52) **U.S. Cl.**  
USPC ..... **D14/489**; D14/488

**DESCRIPTION**

(58) **Field of Classification Search**  
USPC ..... D14/485–493  
CPC .... G06F 3/0481; G06F 3/0482; G06F 3/0488;  
G06F 3/04817; G08G 1/20; G08G 1/123;  
G06Q 30/06

FIG. 1 is a front view of a first image in a sequence of a display panel with an animated graphical user interface; FIG. 2 is a second image thereof; FIG. 3 is a third image thereof; FIG. 4 is a fourth image thereof; FIG. 5 is a fifth image thereof; FIG. 6 is a sixth image thereof; and, FIG. 7 is a seventh image thereof.

See application file for complete search history.

The broken line showing of the display screen and portions of the graphical user interface, including around the dot, are included for the purpose of illustrating environmental structure and portions of the article and form no part of the claimed design.

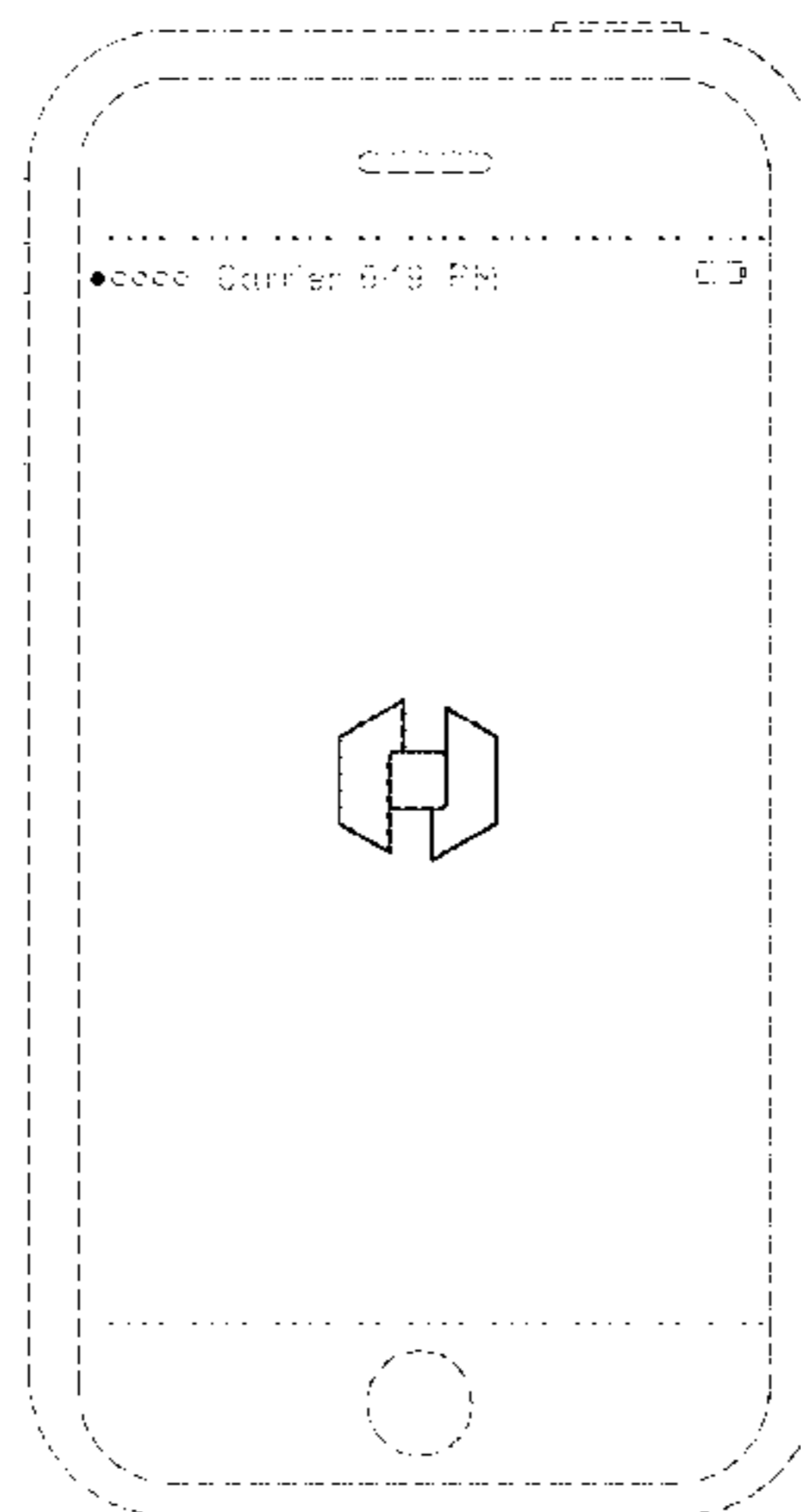
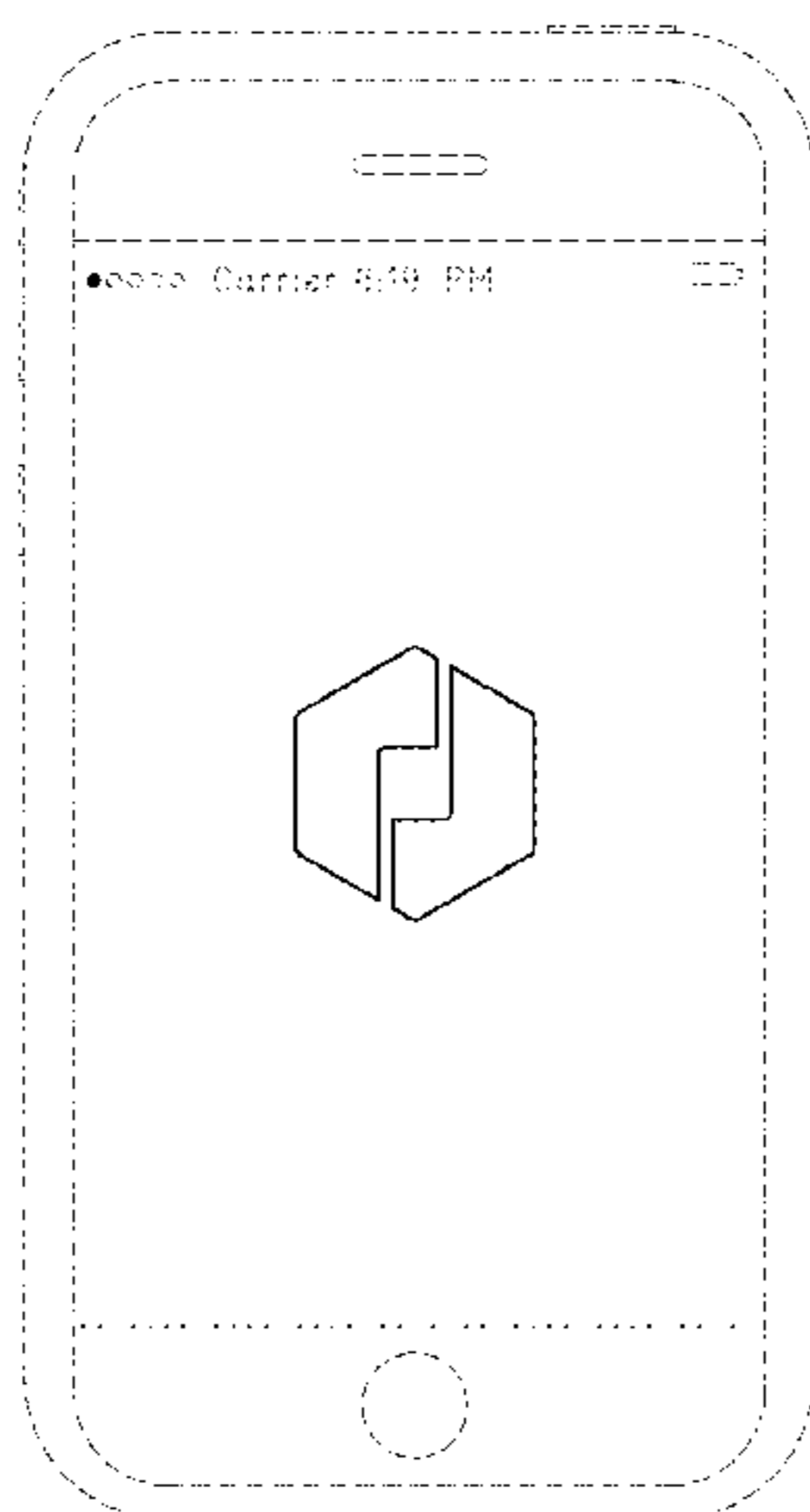
(56) **References Cited**

U.S. PATENT DOCUMENTS

5,898,435 A \* 4/1999 Nagahara ..... G06F 3/04815  
715/841  
D462,122 S \* 8/2002 Hutcheson ..... D24/169  
D536,343 S \* 2/2007 Fong ..... D14/489  
D602,028 S \* 10/2009 Queric ..... D14/485  
D624,557 S \* 9/2010 Allen ..... D14/488  
D630,643 S \* 1/2011 Wilson ..... D14/486  
D630,644 S \* 1/2011 Wilson ..... D14/486  
D650,793 S \* 12/2011 Impas ..... D14/489

The appearance of the transitional image sequentially transitions between the images shown in FIGS. 1-7. The process or period in which one image transitions to another image forms no part of the claimed design.

**1 Claim, 7 Drawing Sheets**



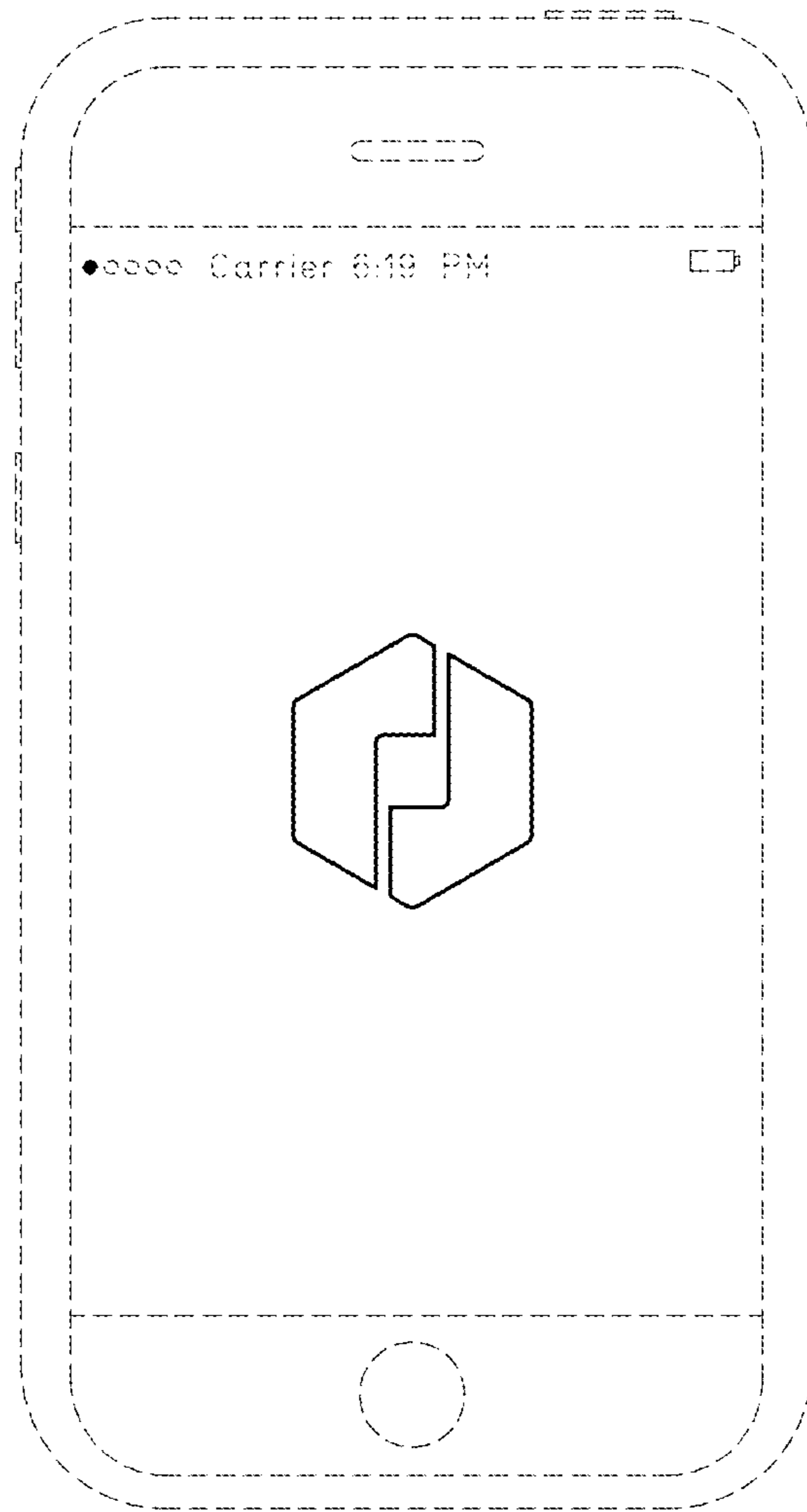
(56)

References Cited

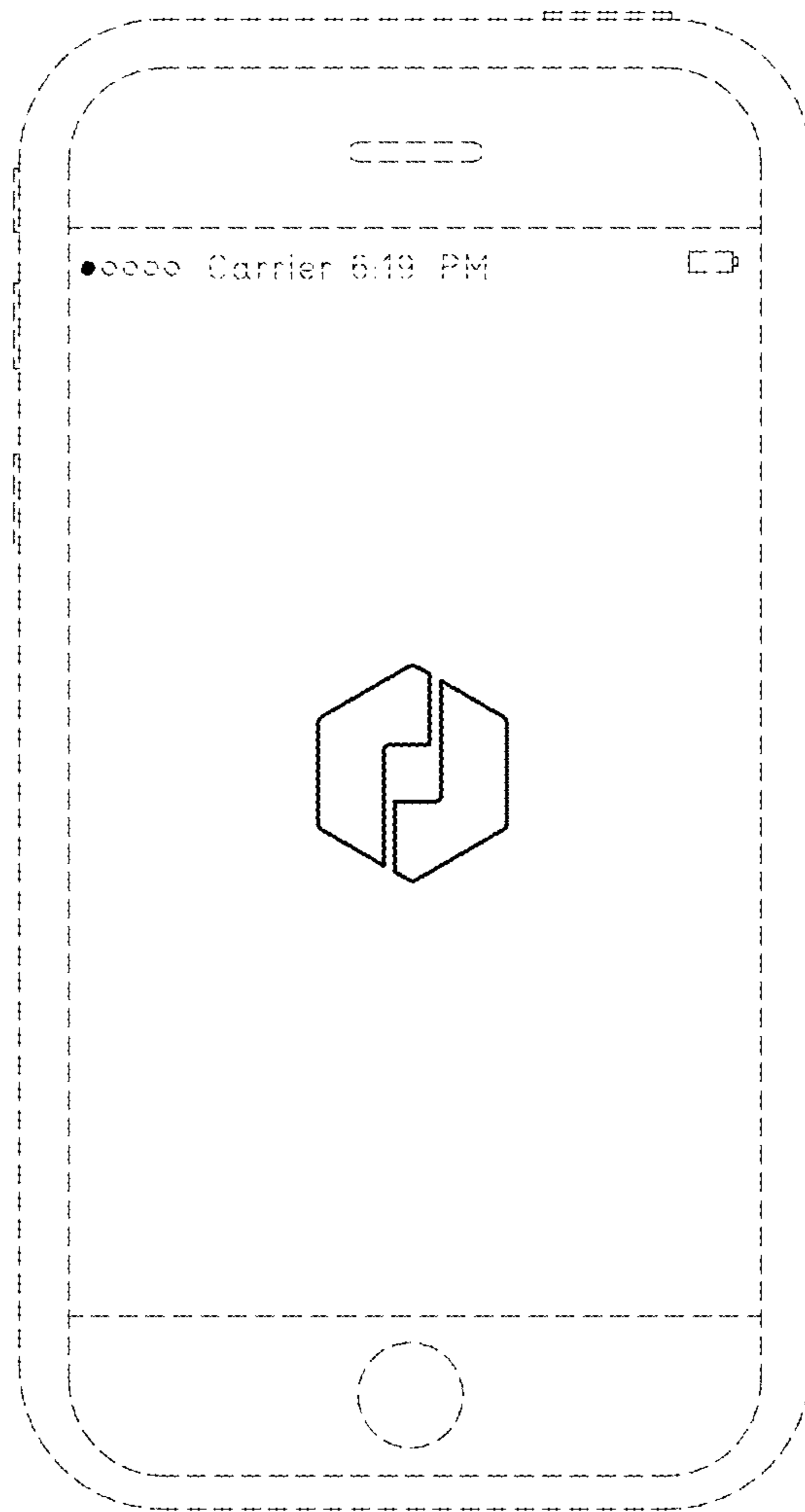
U.S. PATENT DOCUMENTS

D704,735	S *	5/2014	Hollobaugh .....	D14/489
D711,912	S *	8/2014	Alldredge .....	D14/489
D719,189	S *	12/2014	Brinda .....	D14/492
D738,910	S *	9/2015	Drozd .....	D14/488
D744,535	S *	12/2015	Shin .....	D14/489
D745,047	S *	12/2015	Torres .....	D14/489
D745,051	S *	12/2015	Kim .....	D14/491
D750,650	S *	3/2016	Lee .....	D14/486
D757,101	S *	5/2016	Woo .....	D14/489
D760,778	S *	7/2016	Lee .....	D14/489
D760,785	S *	7/2016	Kim .....	D14/492
D761,840	S *	7/2016	Patterson .....	D14/488
D764,493	S *	8/2016	Sanderson .....	D14/485
D765,676	S *	9/2016	Joo .....	D14/485
D771,126	S *	11/2016	Cho .....	D14/489
D774,080	S *	12/2016	Yoo .....	D14/489
D774,081	S *	12/2016	Yoo .....	D14/489
D780,804	S *	3/2017	Cho .....	D14/489
D783,673	S *	4/2017	Xu .....	D14/489
D783,676	S *	4/2017	Kim .....	D14/489
D797,799	S *	9/2017	Bunyard .....	D14/491
2005/0280521	A1 *	12/2005	Mizumaki .....	B60K 35/00 340/438
2009/0327939	A1 *	12/2009	Johns .....	G11B 27/34 715/765
2013/0104071	A1 *	4/2013	Boutoussov .....	G06F 19/3406 715/781
2017/0220237	A1 *	8/2017	Jow .....	G06F 3/04845

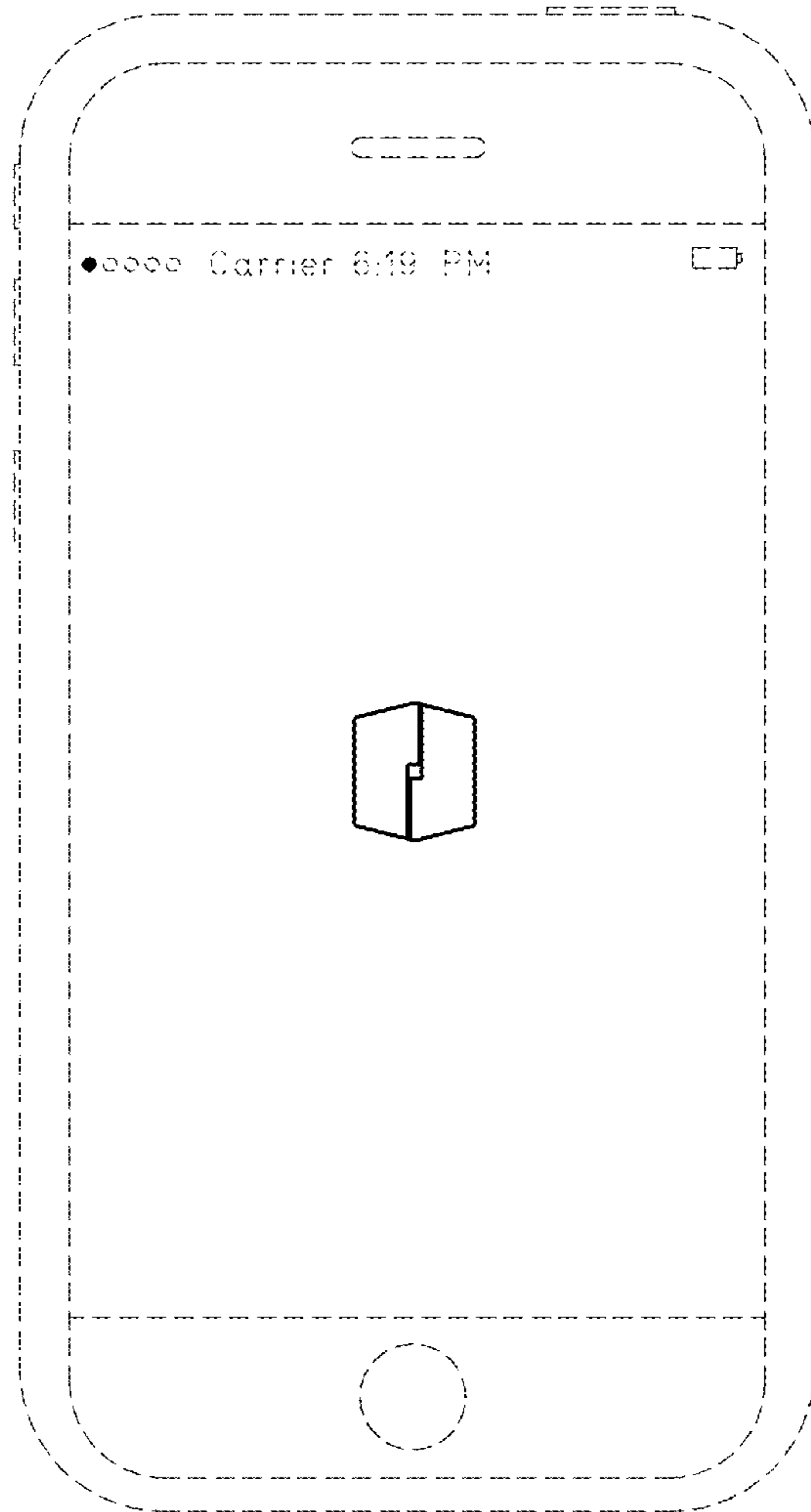
\* cited by examiner



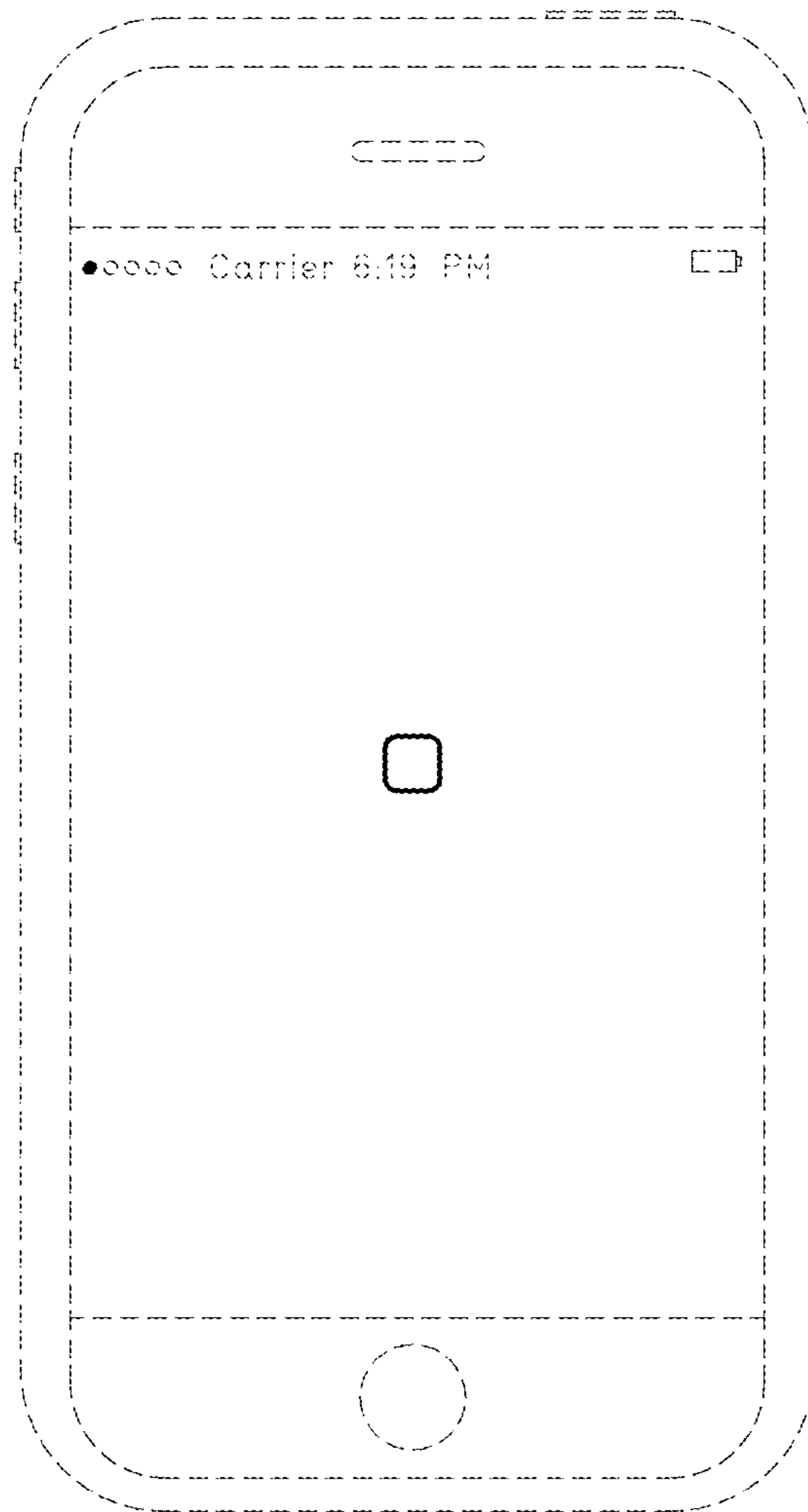
***Fig. 1***



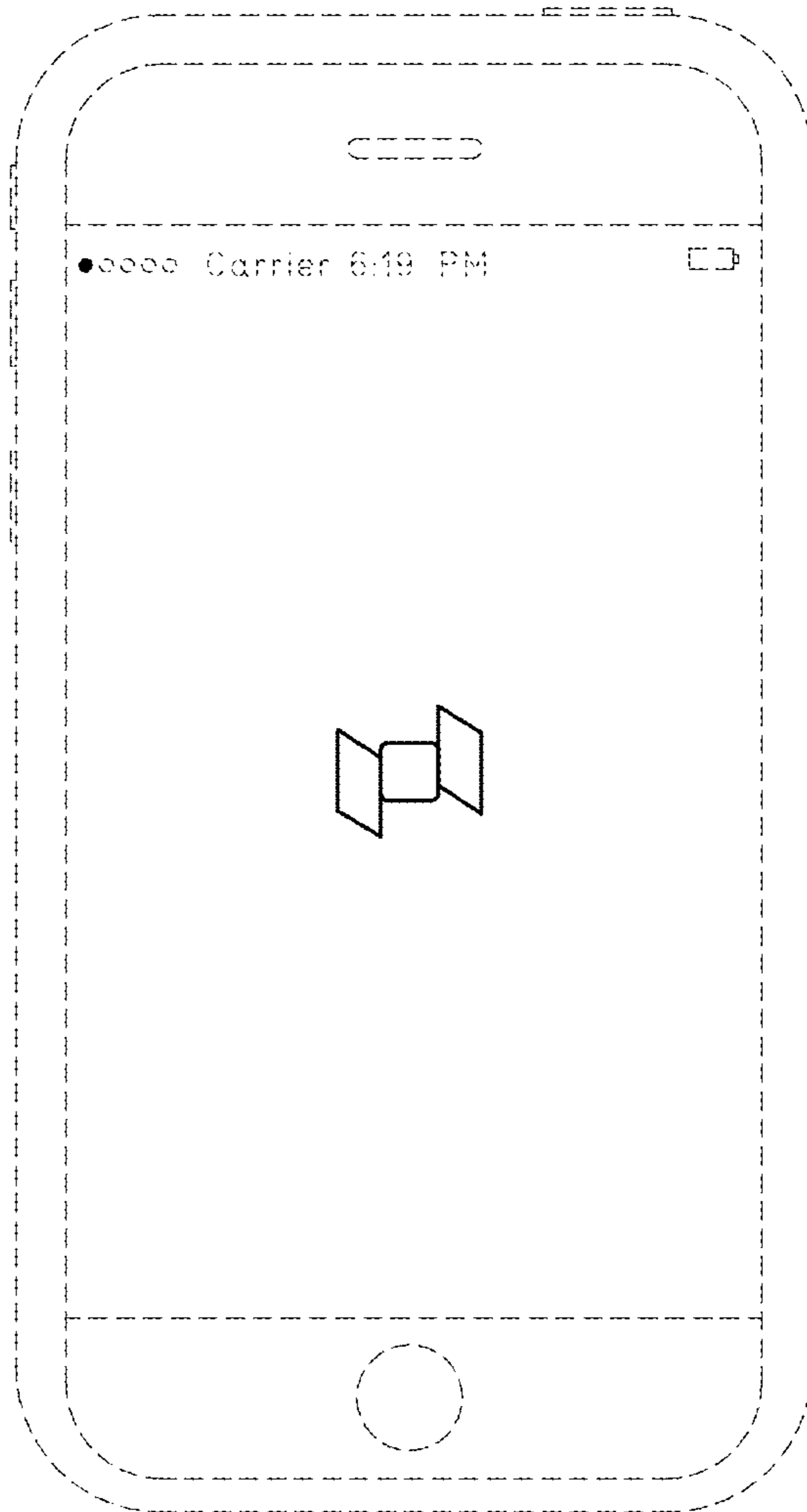
***Fig. 2***



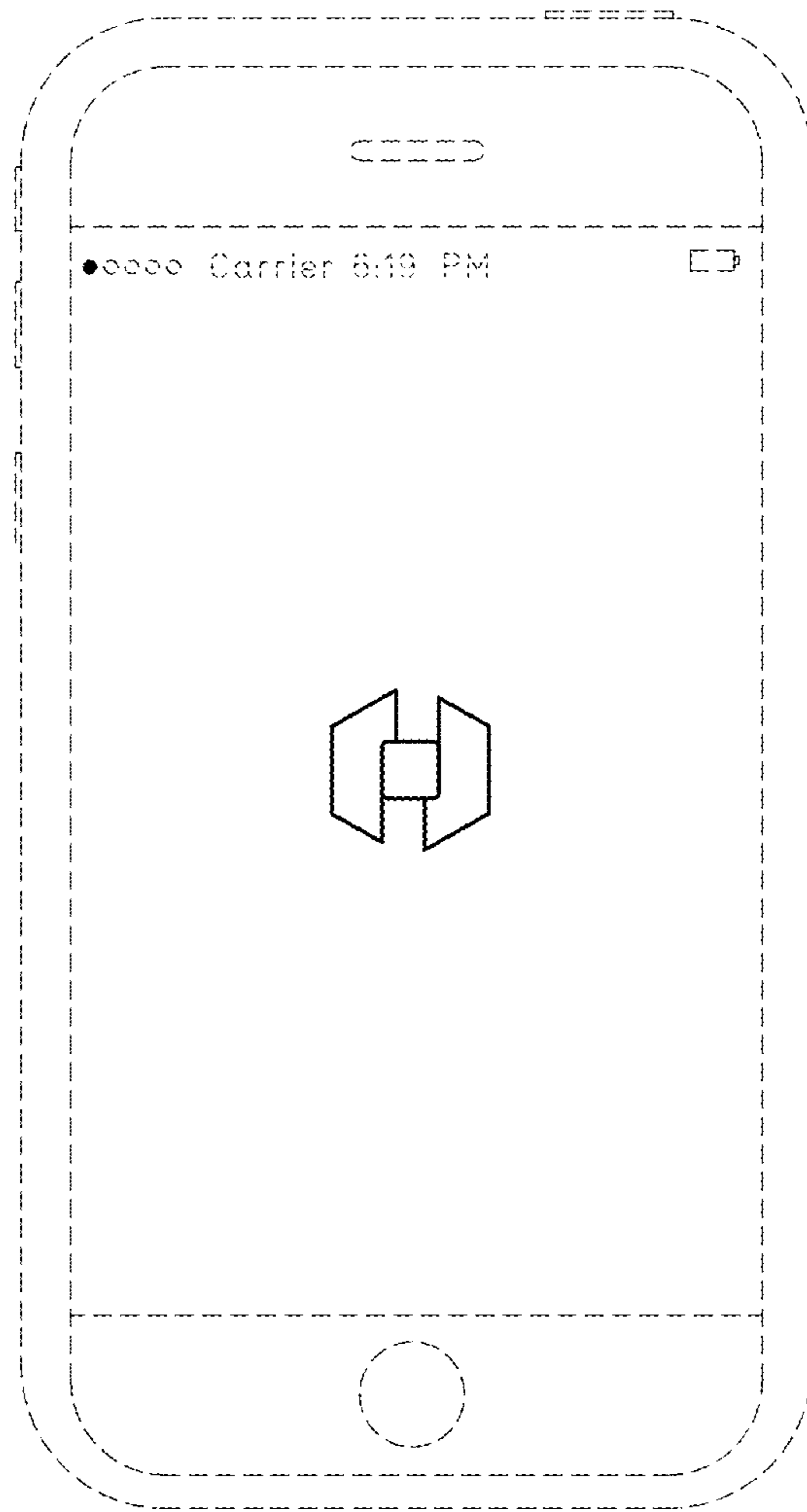
***Fig. 3***



*Fig. 4*

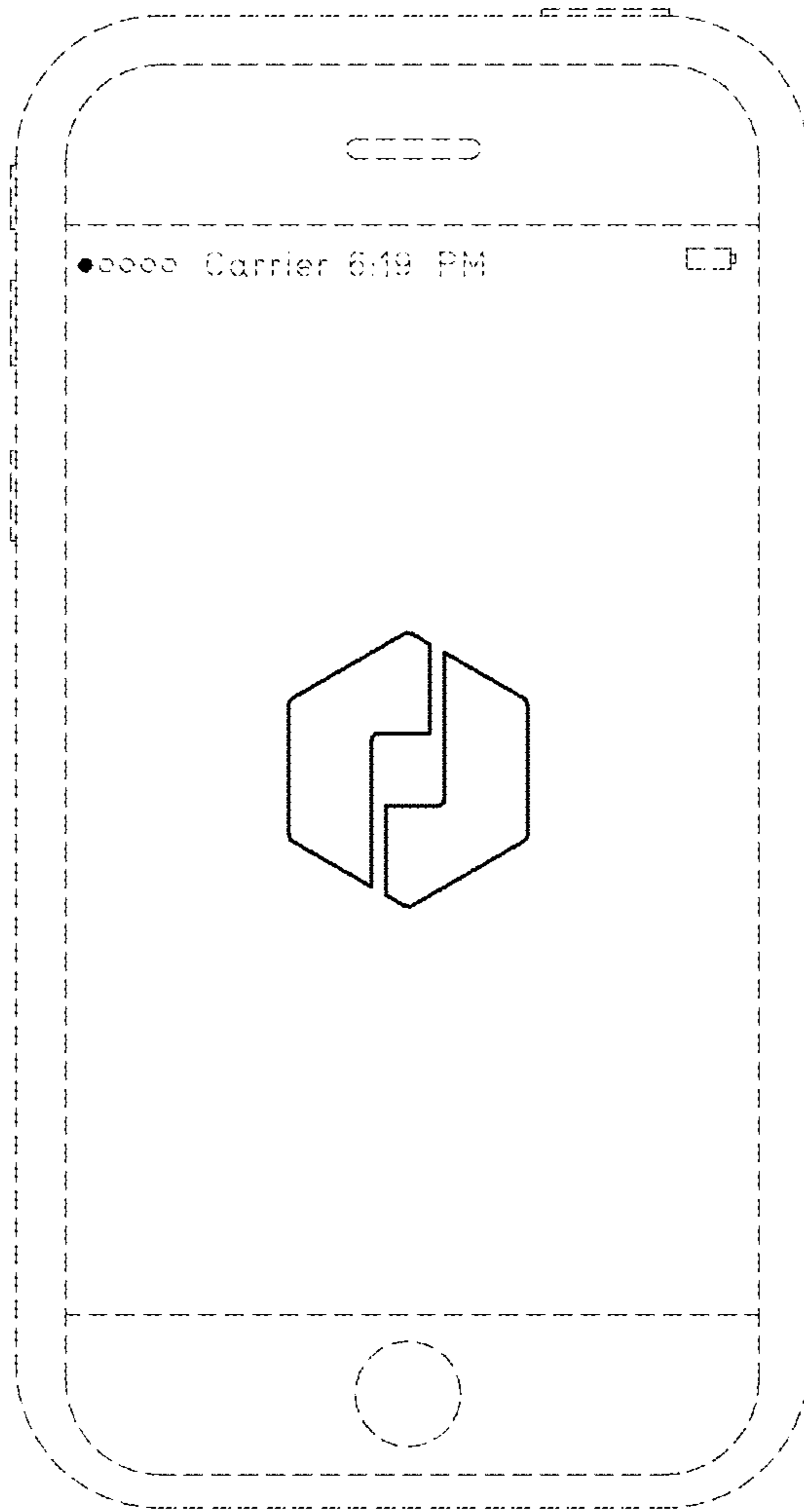


***Fig. 5***



***Fig. 6***





***Fig. 7***