



US00D811998S

(12) **United States Design Patent**
Wang

(10) **Patent No.:** **US D811,998 S**
(45) **Date of Patent:** **** Mar. 6, 2018**

(54) **CAR CHARGER**

(71) Applicant: **Hao Wang**, Guangdong (CN)

(72) Inventor: **Hao Wang**, Guangdong (CN)

(**) Term: **15 Years**

(21) Appl. No.: **29/580,794**

(22) Filed: **Oct. 13, 2016**

(30) **Foreign Application Priority Data**

Apr. 13, 2016 (CN) 2016 3 0122509

(51) **LOC (11) Cl.** **13-02**

(52) **U.S. Cl.**
USPC **D13/107; D13/144**

(58) **Field of Classification Search**
USPC D13/102–110, 118–119, 184, 199, 144,
D13/133; D14/356, 432, 155
CPC Y02E 60/10; Y02E 60/12; Y02E 60/122;
Y02E 60/124; Y02E 60/50; H01M 2/02;
H01M 2/022; H01M 2/0202; H01M
2/0207; H01M 2/0212; H01M 2/1061;
H01M 2/1022; H01M 2/1055; H01M
2/1066; H01M 2/105; H01M 2/20; H01M
2/202; H01M 2/204; H01M 2/206; H01M
10/44; H01M 10/46; H01M 10/465;
H01M 10/482; H01M 2200/30; H01M
2250/30; H01M 2250/40; H02J 7/00;
H02J 7/0003; H02J 7/0011; H02J 7/0013;
H02J 7/0054; H02J 7/0055; H02J 7/0057;
H02J 2007/0062

See application file for complete search history.

(56) **References Cited**

U.S. PATENT DOCUMENTS

D618,618 S * 6/2010 Lee D13/108
D700,572 S * 3/2014 Esses D13/108
D701,838 S * 4/2014 Esses D13/108
D709,892 S * 7/2014 Lui D14/433

D714,223 S * 9/2014 Huang D13/144
D714,727 S * 10/2014 Cai D13/144
D718,242 S * 11/2014 Aspinall D13/144
D719,916 S * 12/2014 Cheng D13/144
D733,046 S * 6/2015 Shin D13/107
D747,681 S * 1/2016 Lee D13/108
D786,885 S * 5/2017 Eliyahu D14/480.1

(Continued)

OTHER PUBLICATIONS

RapidX X5 USB Car Charger, RapidX, reviewed on Feb. 19, 2017 on amazon.com, retrieved on Sep. 21, 2017, retrieved from the Internet URL: <https://www.amazon.com/RapidX-Extended-Charging-Intelligent-Recognition/dp/B01J3S9I7K>.*

Primary Examiner — Rosemary K Tarcza
Assistant Examiner — Alison M Ofstun

(57) **CLAIM**

The ornamental design for a car charger, as shown and described.

DESCRIPTION

FIG. 1 is a first perspective view of a car charger comprising a first component and a second component showing my new design;
FIG. 2 is a second perspective view thereof;
FIG. 3 is a first perspective view of a first component of a car charger shown separately for ease of illustration;
FIG. 4 is a second perspective view thereof;
FIG. 5 is a third perspective view thereof;
FIG. 6 is a fourth perspective view thereof;
FIG. 7 is a first perspective view of a second component of a car charger shown separately for ease of illustration;
FIG. 8 is a second perspective view thereof;
FIG. 9 is a third perspective view thereof; and,
FIG. 10 is a fourth perspective view thereof.
The broken lines present in the drawings are included for the purpose of illustrating portions of the article which form no part of the claimed design.

1 Claim, 10 Drawing Sheets

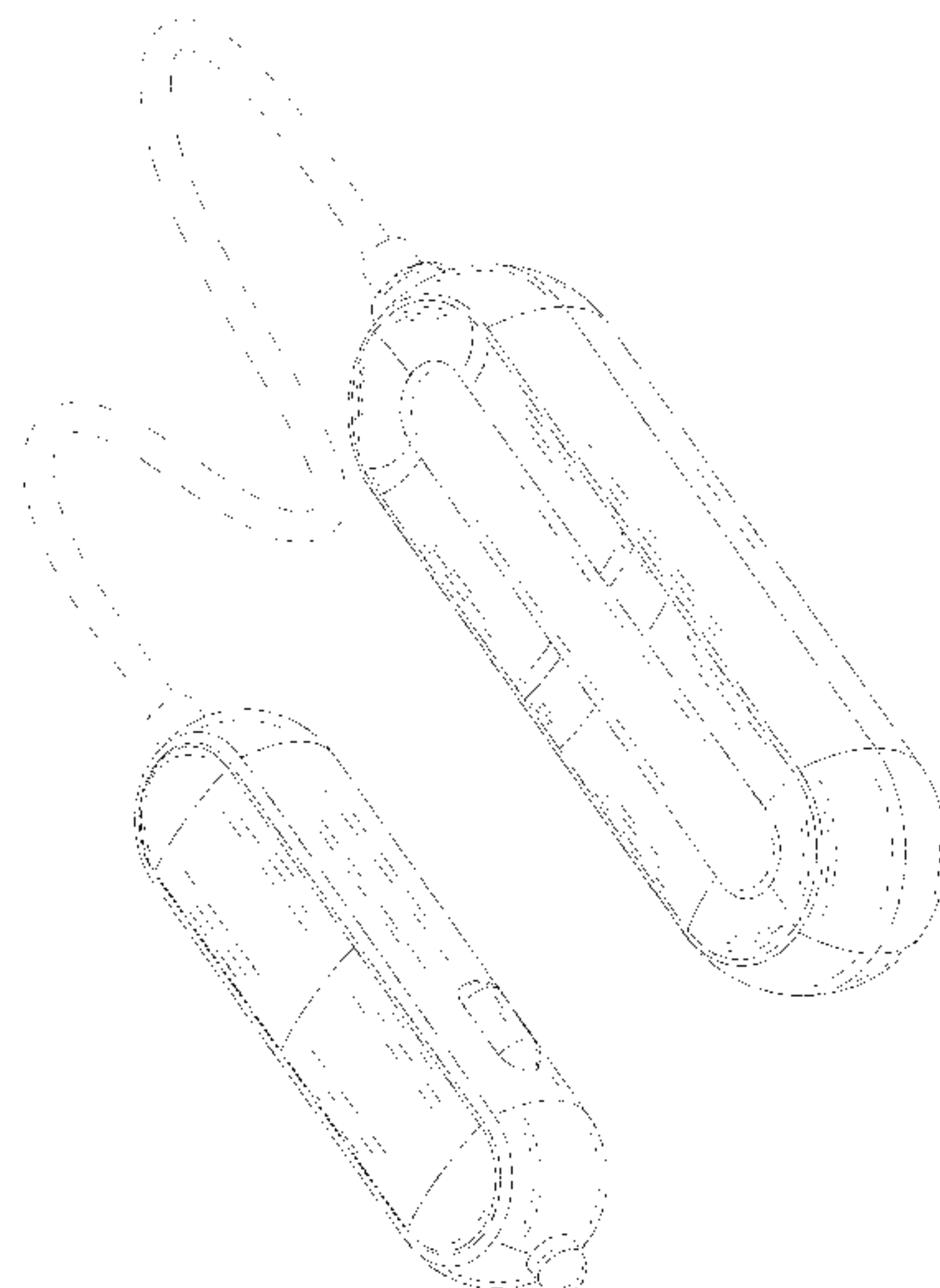

(56)

References Cited

U.S. PATENT DOCUMENTS

D791,138 S * 7/2017 Eliyahu D14/435.1
D796,446 S * 9/2017 Hahn D13/144

* cited by examiner

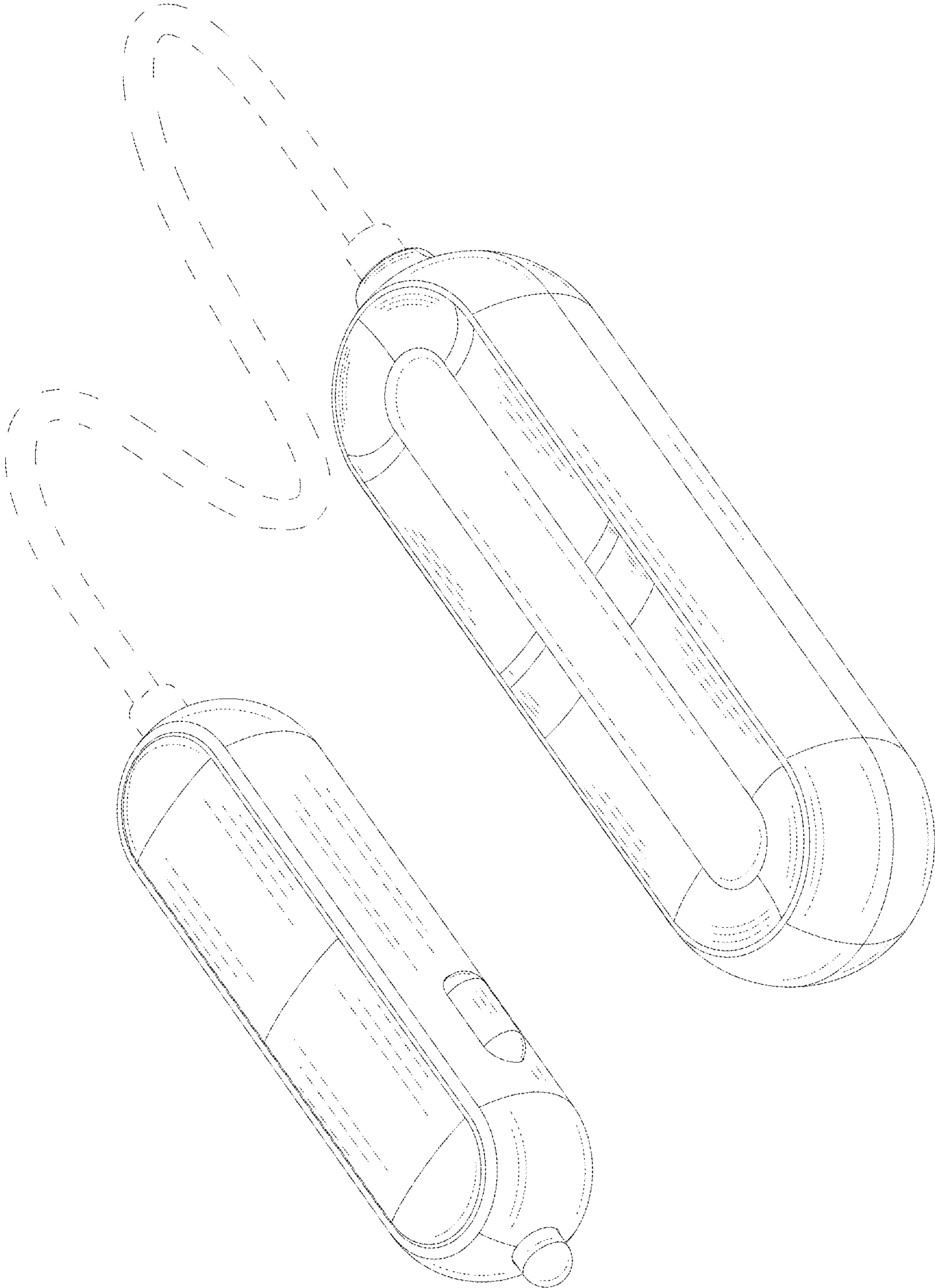

Fig.1

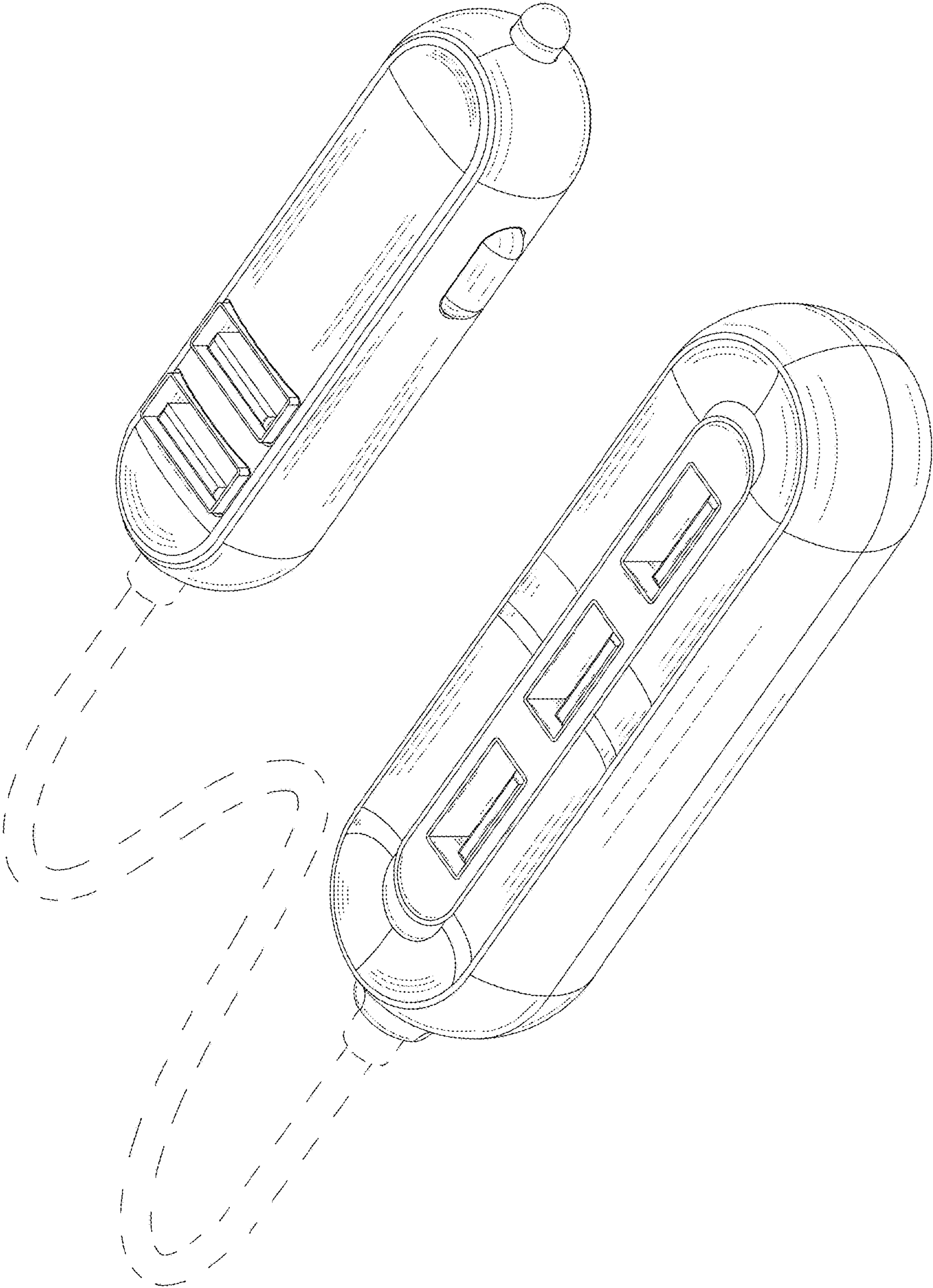

Fig.2

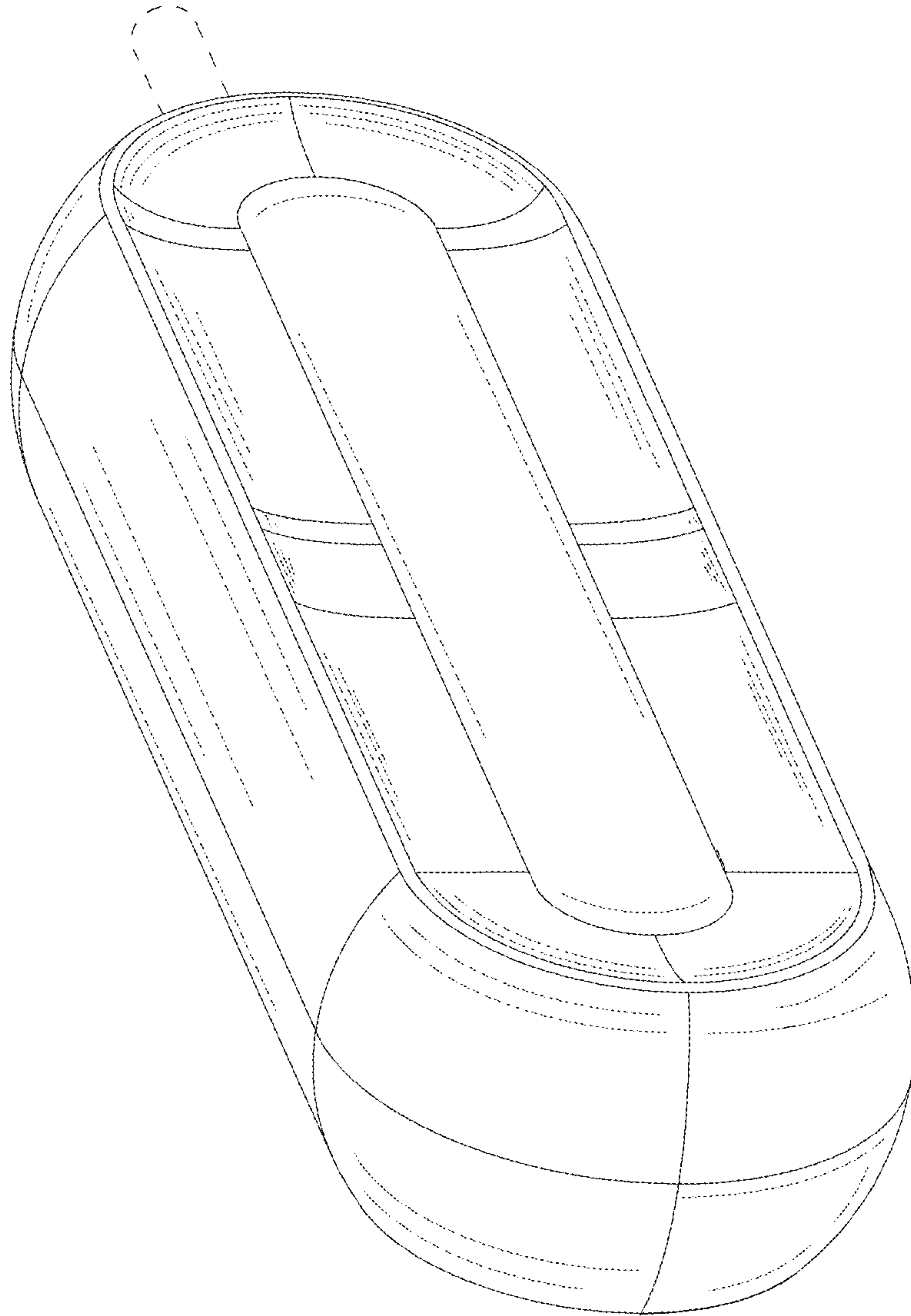

Fig.3

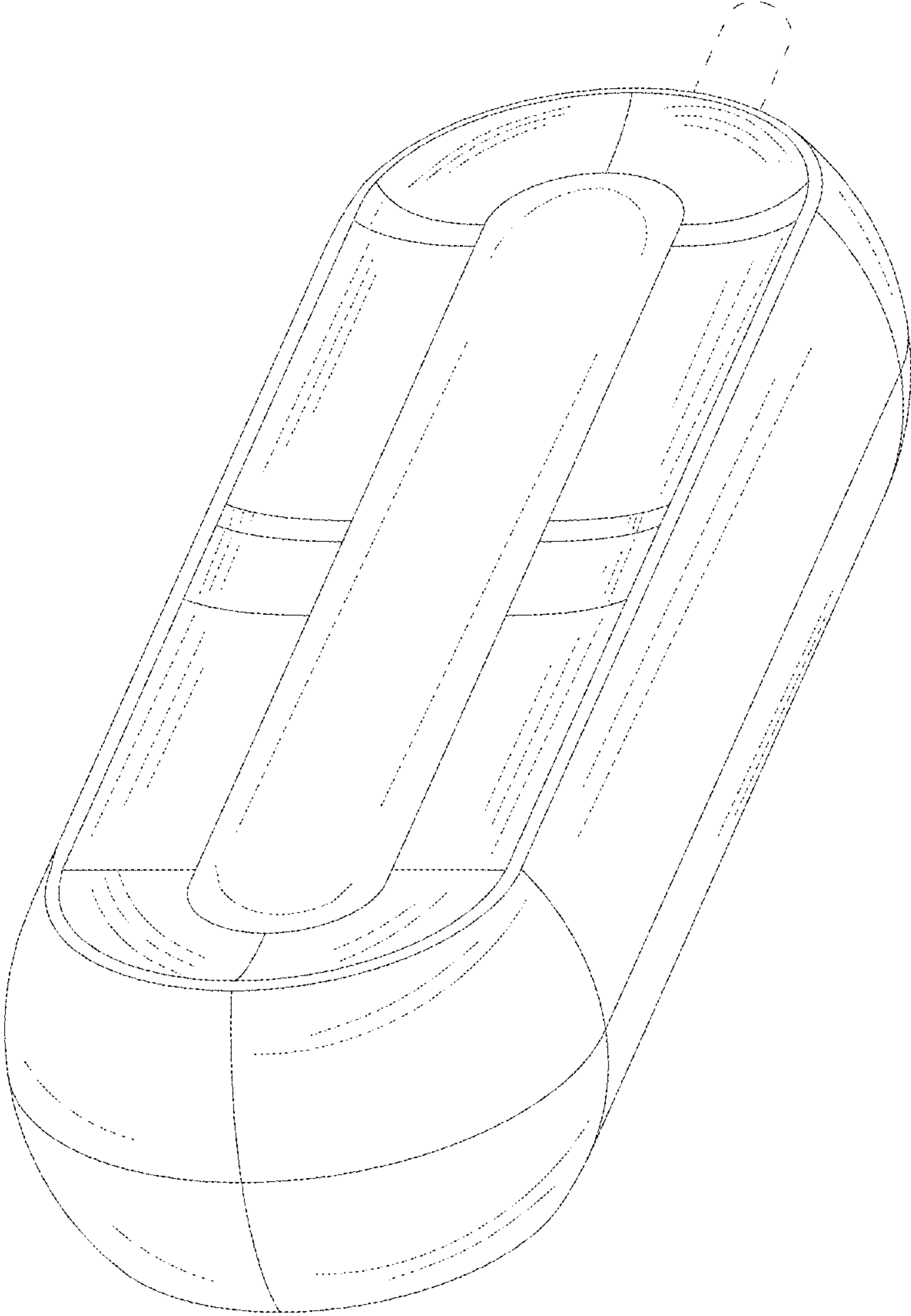

Fig.4

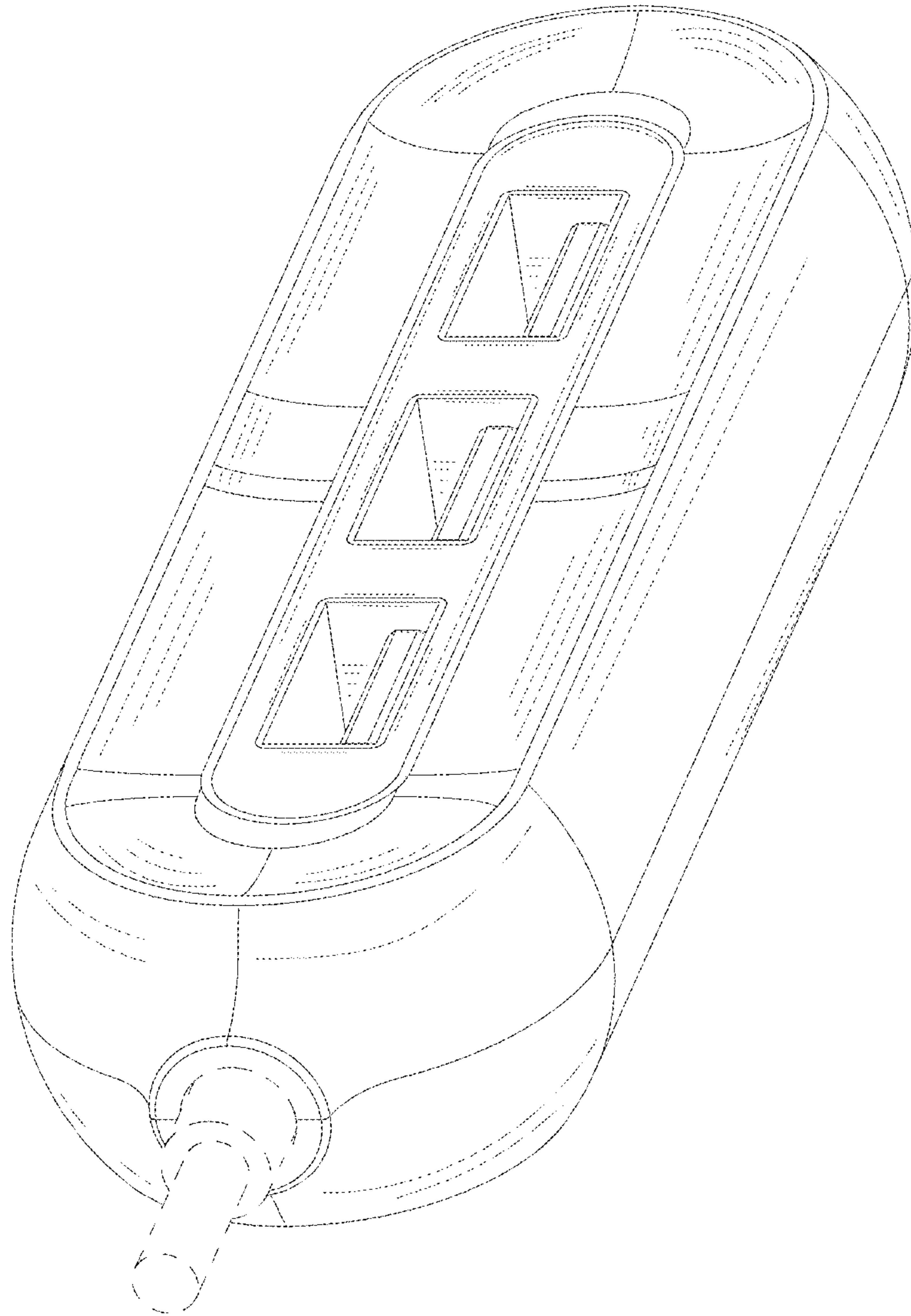

Fig.5

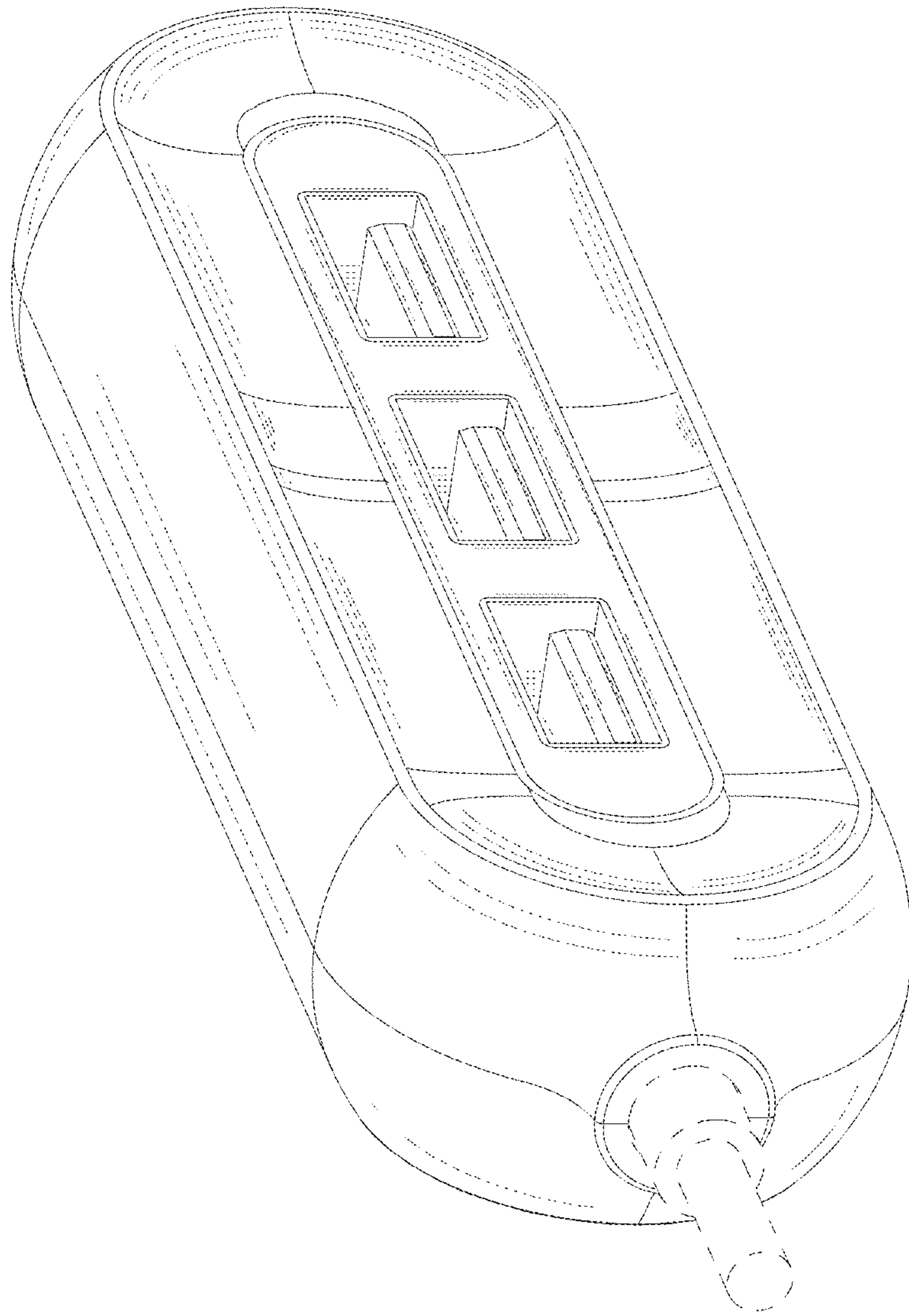

Fig.6

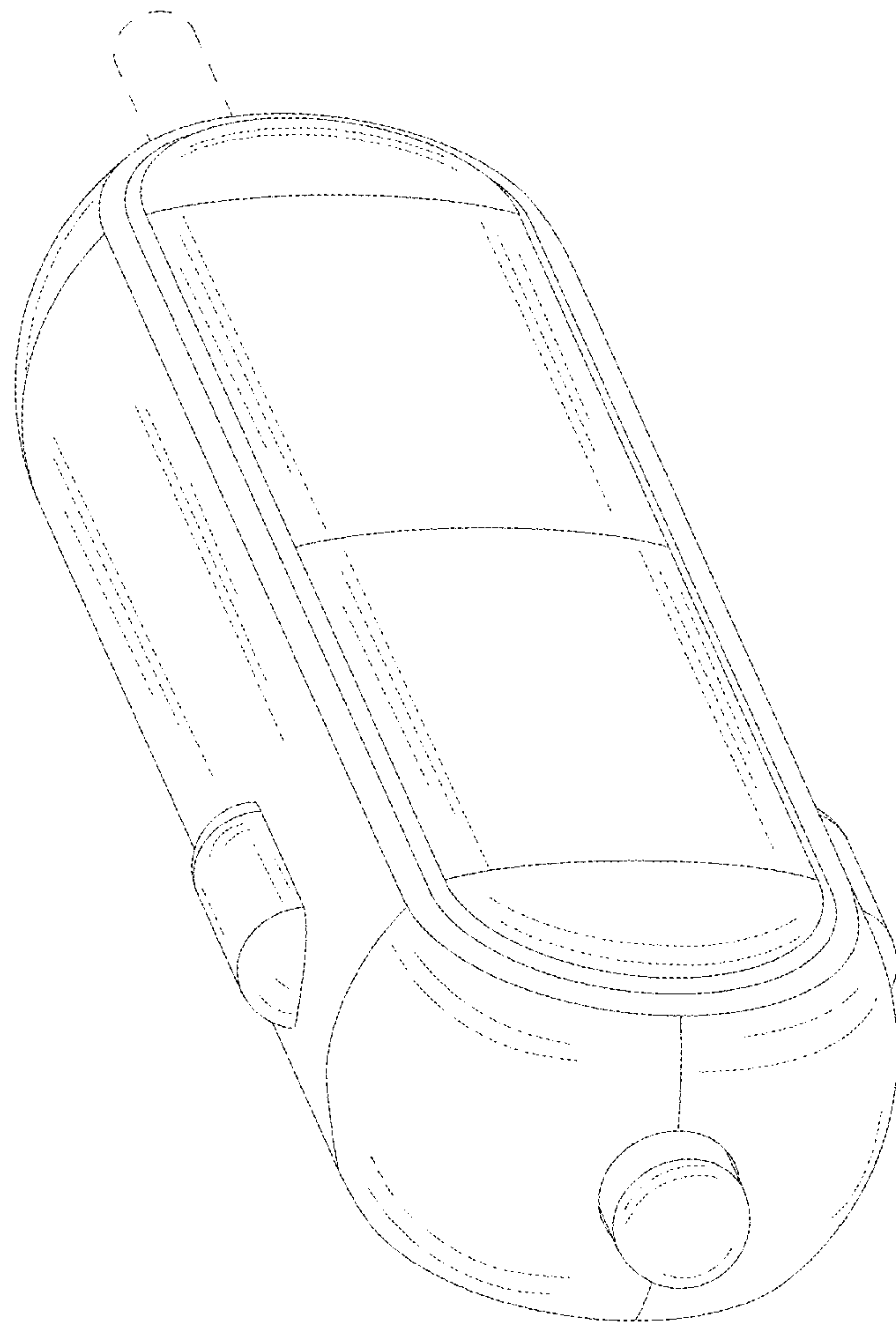

Fig.7

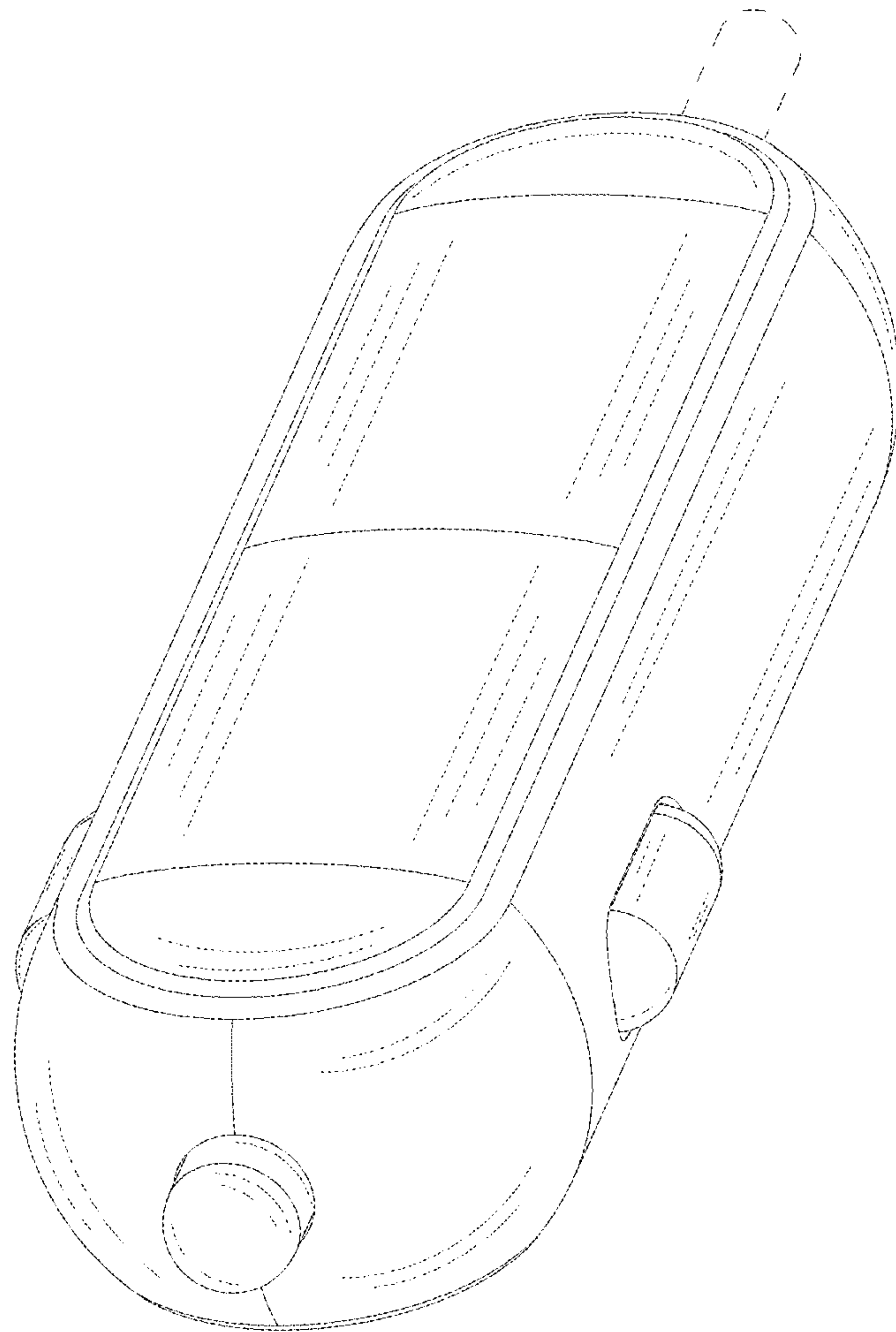

Fig.8

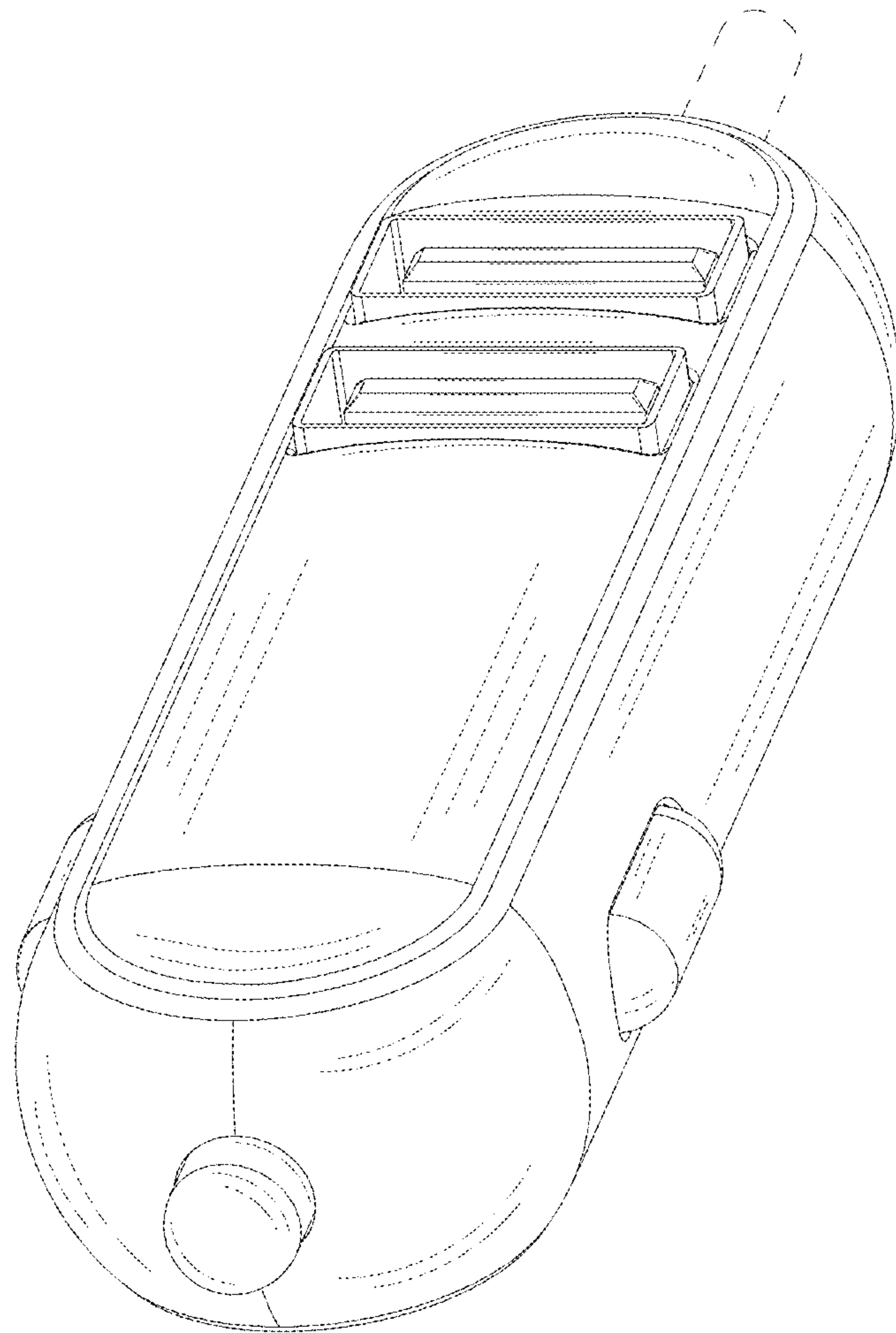

Fig.9

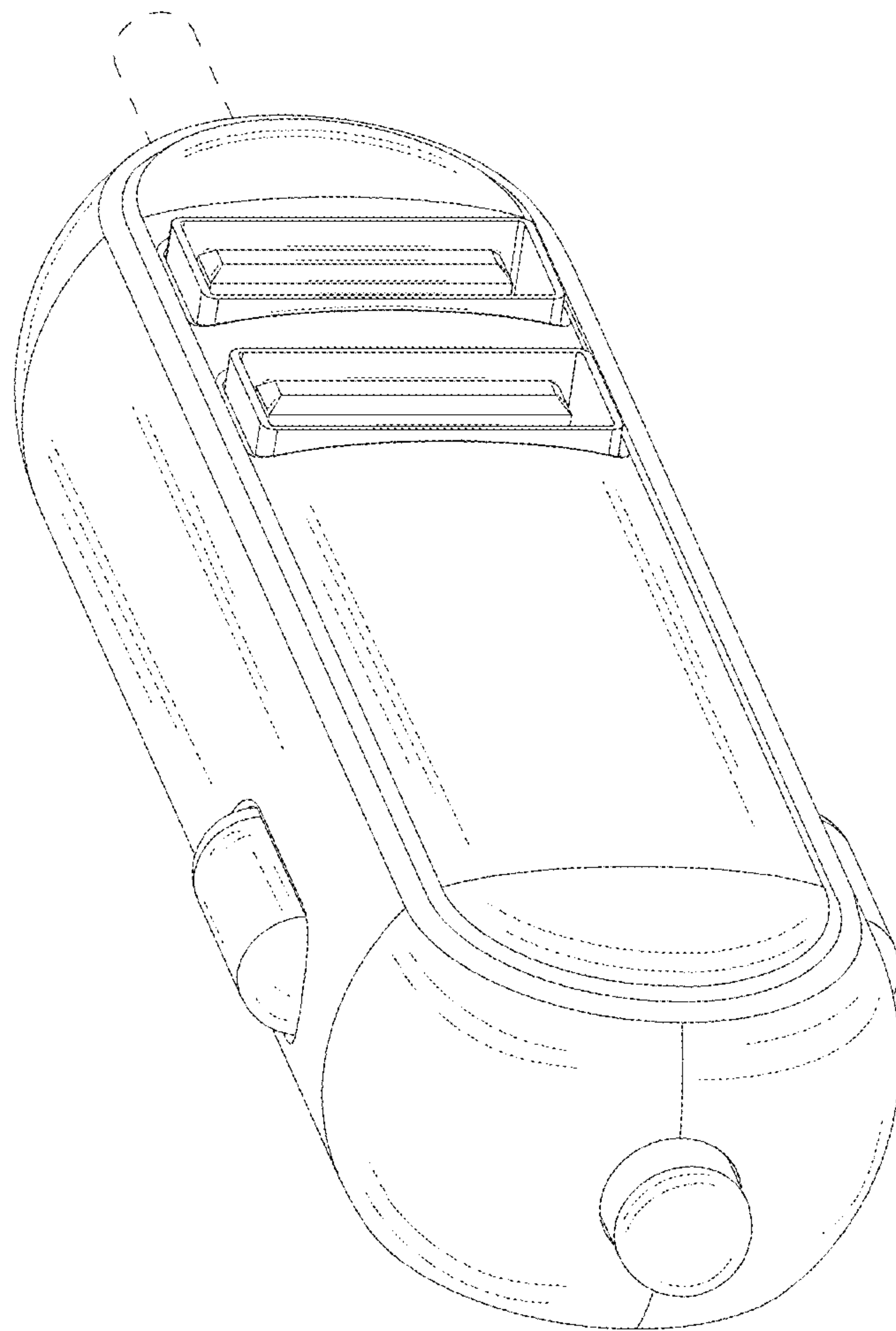

Fig.10