



US00D811976S

(12) **United States Design Patent**
Wu

(10) **Patent No.:** **US D811,976 S**
(45) **Date of Patent:** **** Mar. 6, 2018**

(54) **SIDE RAIL PROTECTOR BAR**

(71) Applicant: **Yim Man Wu**, Elmhurst, NY (US)

(72) Inventor: **Yim Man Wu**, Elmhurst, NY (US)

(**) Term: **15 Years**

(21) Appl. No.: **29/594,165**

(22) Filed: **Feb. 16, 2017**

(51) **LOC (11) Cl.** **12-16**

(52) **U.S. Cl.**
USPC **D12/203**

(58) **Field of Classification Search**
USPC D12/203, 162, 89, 190
CPC .. B60R 3/002; B60R 3/02; B60R 3/00; B60R
3/005; B60R 3/007
See application file for complete search history.

(56) **References Cited**

U.S. PATENT DOCUMENTS

D494,914 S *	8/2004	Elwell	D12/203
D495,283 S *	8/2004	Ashley	D12/203
D495,646 S *	9/2004	Elwell	D12/203
D505,901 S *	6/2005	Wang	D12/203
D568,222 S *	5/2008	Storer	D12/203
D665,713 S *	8/2012	Pochurek	D12/203
D671,874 S *	12/2012	Kekich, Jr.	D12/203
D720,674 S *	1/2015	Stanesic	D12/203
D731,384 S *	6/2015	Farr	D12/203

D766,797 S *	9/2016	Li	D12/203
9,796,336 B2 *	10/2017	Crandall	B60R 3/002
2004/0150183 A1 *	8/2004	Clermont	B60R 3/002 280/163
2005/0012294 A1 *	1/2005	Yang	B60R 3/002 280/163
2011/0181012 A1 *	7/2011	Storer	B60R 3/002 280/169
2012/0228848 A1 *	9/2012	Fichter	B60R 3/00 280/163
2013/0221632 A1 *	8/2013	Higgs	B60R 3/00 280/169
2016/0059774 A1 *	3/2016	Crandall	B60Q 1/323 280/164.1

* cited by examiner

Primary Examiner — George D. Kirschbaum

Assistant Examiner — Clese Moore, Jr.

(57) **CLAIM**

I claim, the ornamental design for a side rail protector bar, as shown and described.

DESCRIPTION

FIG. 1 is an orthogonal view of the vehicle side rail protector bar.

FIG. 2 is an end view of the vehicle side rail protector bar.

FIG. 3 is a side view of the vehicle side rail protector bar.

FIG. 4 is a top view of the vehicle side rail protector bar; and,

FIG. 5 is a bottom view of the vehicle side rail protector bar.

1 Claim, 5 Drawing Sheets

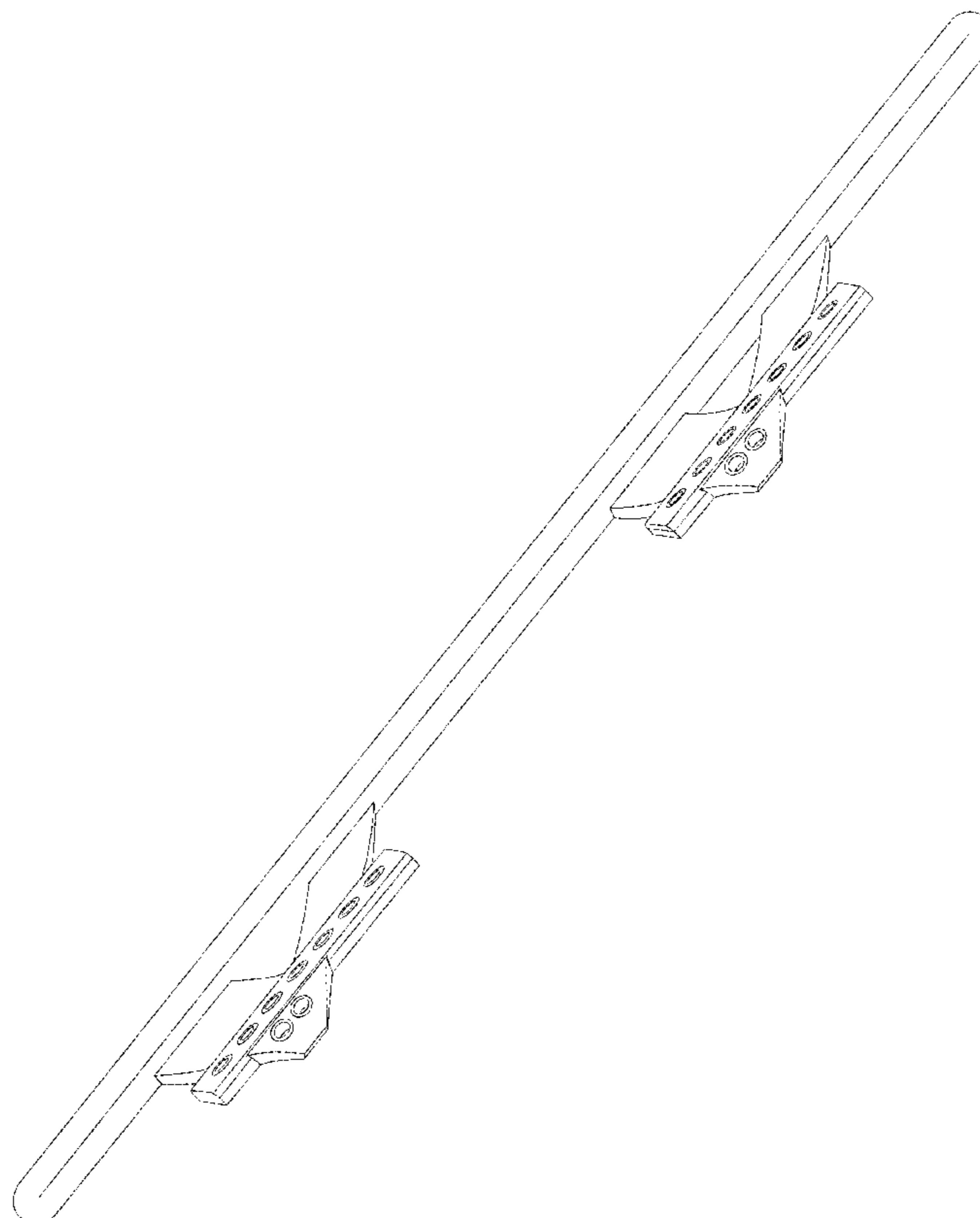

Fig. 1

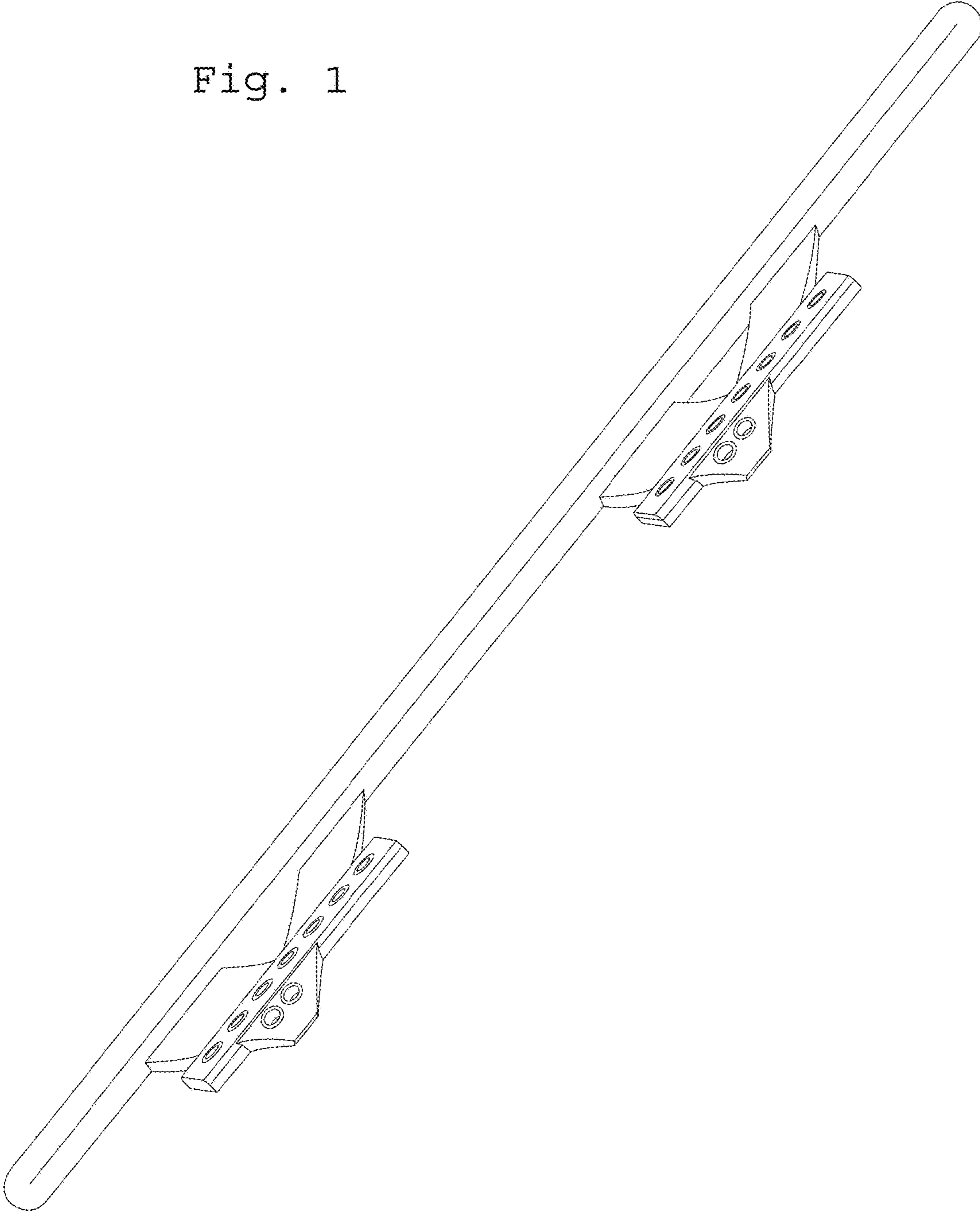

Fig. 2

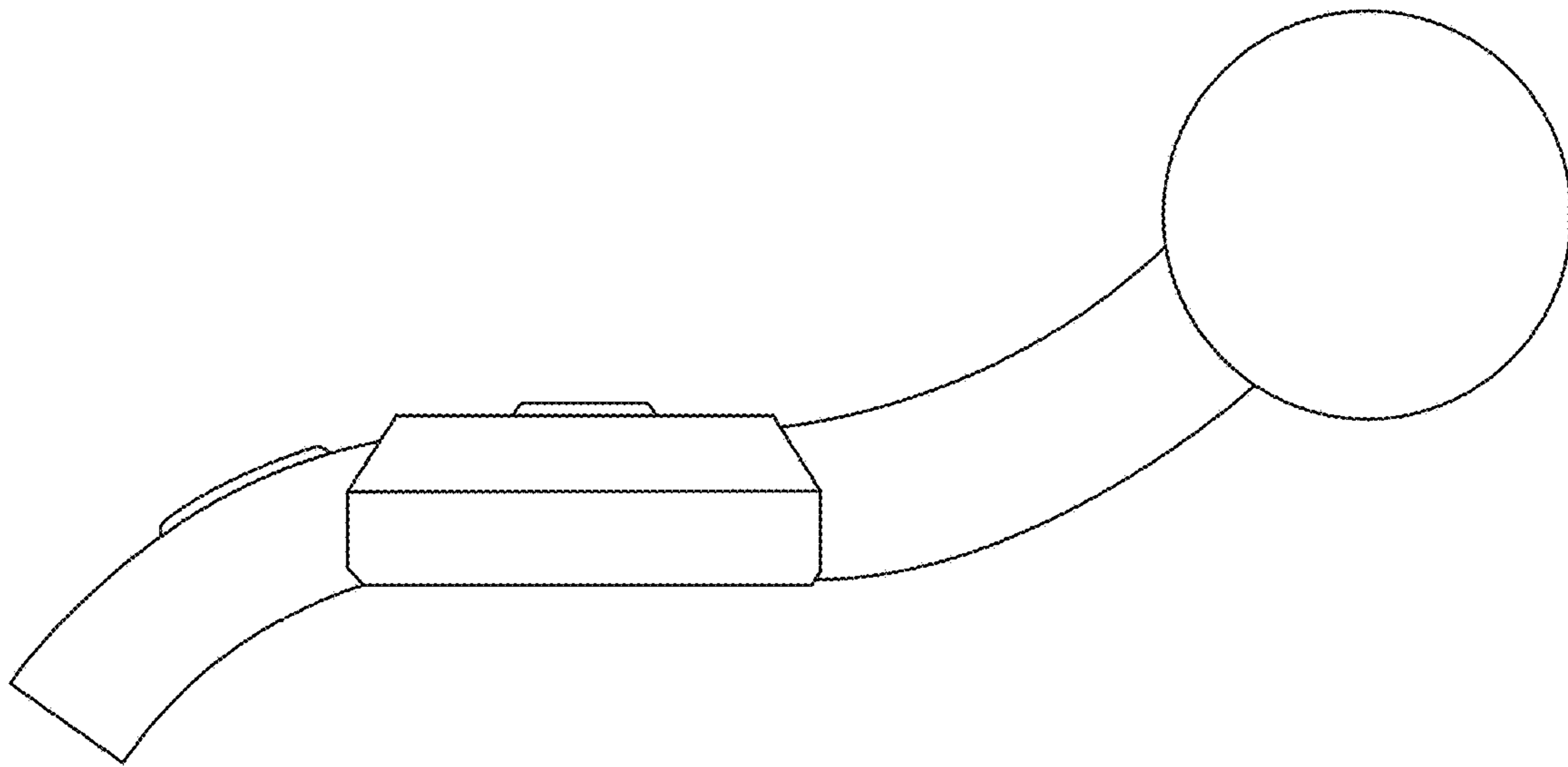

Fig. 3

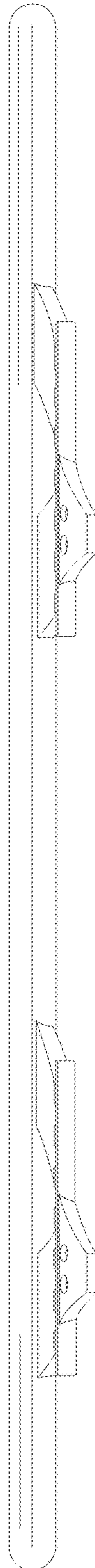

Fig. 4

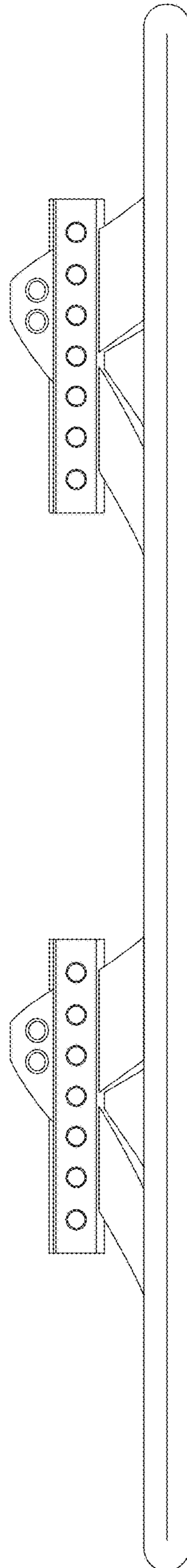

Fig. 5

