



US00D811736S

(12) **United States Design Patent**
Gallet

(10) **Patent No.:** **US D811,736 S**
(45) **Date of Patent:** **** Mar. 6, 2018**

- (54) **HANDBAG**
- (71) Applicant: **Stephanie Gallet**, Santa Monica, CA
(US)
- (72) Inventor: **Stephanie Gallet**, Santa Monica, CA
(US)
- (**) Term: **15 Years**
- (21) Appl. No.: **29/584,844**
- (22) Filed: **Nov. 17, 2016**
- (51) **LOC (11) Cl.** **03-01**
- (52) **U.S. Cl.**
USPC **D3/243**
- (58) **Field of Classification Search**
USPC D3/201, 205, 206, 226, 231-247, 258,
D3/273, 301, 303, 318, 901, 903;
D12/409
CPC A45C 13/02; A45C 13/04; A45C 13/06;
A45C 13/08; A45C 13/26; A45C 1/024;
A45C 7/0077; A45C 3/04; A45C 3/06
See application file for complete search history.

- D613,502 S * 4/2010 Hardy D3/247
- D761,016 S * 7/2016 Barina D3/243
- 2011/0284563 A1* 11/2011 Henderson A45C 13/02
220/694
- 2012/0055959 A1* 3/2012 Hale A45C 3/06
223/84
- 2017/0035164 A1* 2/2017 Dubiner A45C 3/06

OTHER PUBLICATIONS

Purseblog, Want it Wednesday: Novelty Bags, posted on Feb. 25, 2015, [online], [site visited on Jul. 19, 2017]. Available from Internet, URL: <http://www.purseblog.com/novelty-bags/want-wednesday-novelty-bags-new-normal/>.*

(Continued)

Primary Examiner — Sheryl Lane
Assistant Examiner — Samantha N Wood
(74) *Attorney, Agent, or Firm* — Gottlieb, Rackman & Reisman, PC

(57) **CLAIM**

The ornamental design for a handbag, as shown and described.

DESCRIPTION

FIG. 1 is a front perspective view of a handbag showing my new design;
FIG. 2 is a rear perspective view thereof;
FIG. 3 is a front view thereof;
FIG. 4 is a rear view thereof;
FIG. 5 is a first side view thereof;
FIG. 6 is a second side view thereof;
FIG. 7 is a top view thereof; and,
FIG. 8 is a bottom view thereof.
The broken lines showing portions of the handbag are included for the purpose of illustrating portions of the article and form no part of the claimed design.

1 Claim, 8 Drawing Sheets

(56) **References Cited**
U.S. PATENT DOCUMENTS

- D69,794 S * 3/1926 Christopher D3/235
- D70,795 S * 8/1926 Lehman D3/240
- D137,864 S * 5/1944 Jolles 150/118
- D161,738 S * 1/1951 Cowen D3/240
- D176,924 S * 2/1956 Michaels D3/241
- 3,133,576 A * 5/1964 Stines A45C 13/08
150/110
- 6,152,202 A * 11/2000 Magid A45C 3/06
150/112
- D517,420 S * 3/2006 Scheider D3/240
- D519,732 S * 5/2006 Gonzalez D3/243
- D541,527 S * 5/2007 Schewe D3/238

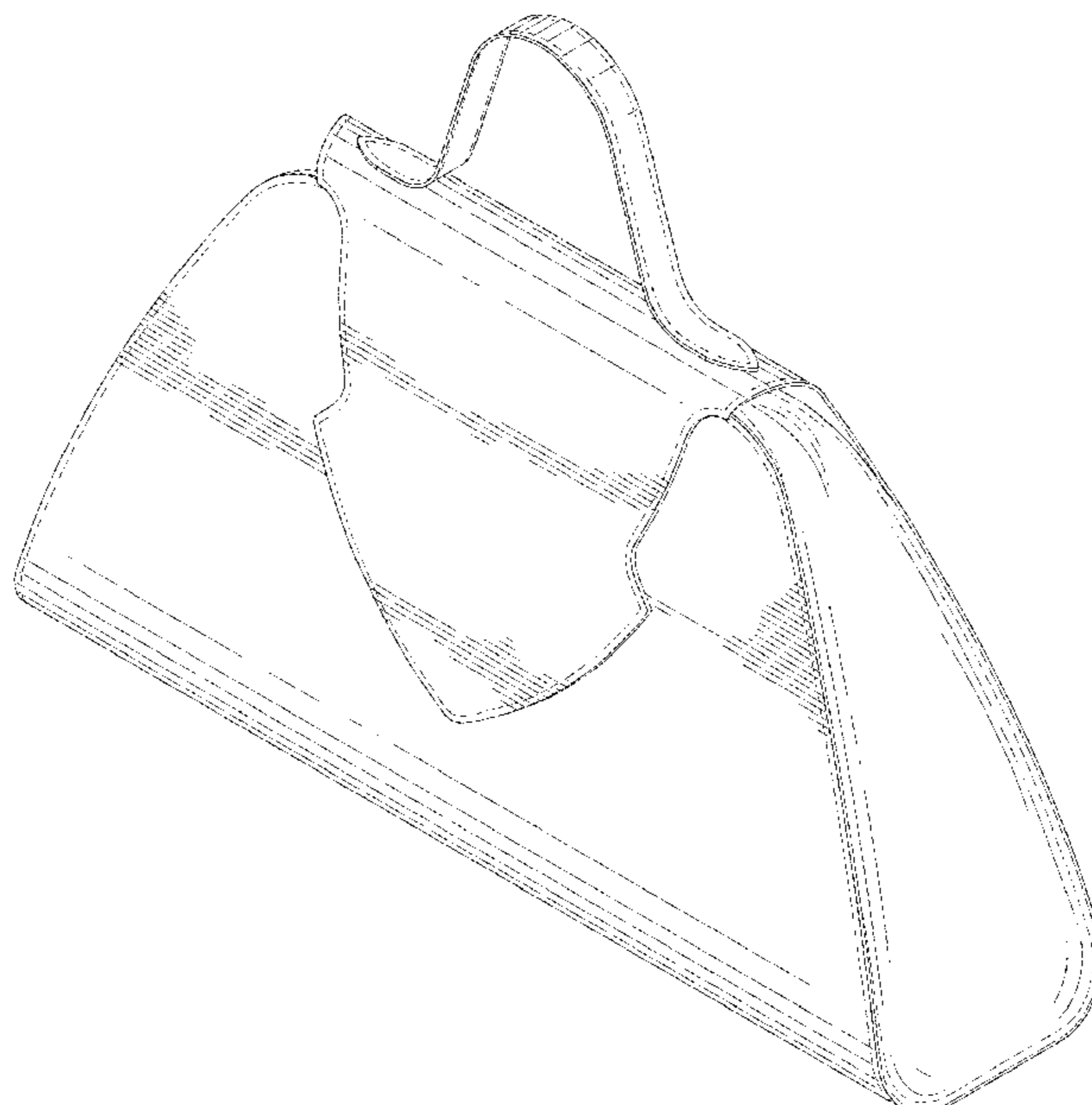

(56)

References Cited

OTHER PUBLICATIONS

Vintage Purse a Day, 1960s Simon Brothers Brown Raffia Half Circle Purse, posted Dec. 16, 2012, [online], [site visited on Jul. 19, 2017]. Available from Internet, URL: <http://vintagepurse.blogspot.com/2012/12/1960s-simon-brothers-brown-raffia-half.html>.*

Purseblog, Prada Bowler Handbag, posted on May 18, 2007, [online], [site visited on Jul. 19, 2017]. Available from Internet, URL: <http://www.purseblog.com/trends/prada-bowler-handbag/>.*

IloveBunny, Bag Review: Chanel Mademoiselle Bowling Bag, posted on Mar. 6, 2012, [online], [site visited on Jul. 19, 2017]. Available from Internet, URL: <http://ilovebunny.net/2012/03/bag-review-chanel-mademoiselle-bowling.html>.*

Yoogi'S Closet, Chanel Beige Fonce Calfskin Leather Luxe Ligne Bowling Bag, handbag production in 2006, [online], [site visited on Jul. 19, 2017]. Available from Internet, URL: <https://www.yoogiscloset.com/handbags/chanel-beige-fonce-calfskin-leather-luxe-ligne-large-bowling-bag.html>.*

Bag Borrow or Steal, Louis Vuitton Etoile Bowling Bag, circa 2008, [online], [site visited on Jul. 19, 2017]. Available from Internet, URL: <http://www.bagborroworsteal.com/handbags/louis-vuitton-monogram-canvas-etoile-bowling-bag/65503>.*

* cited by examiner

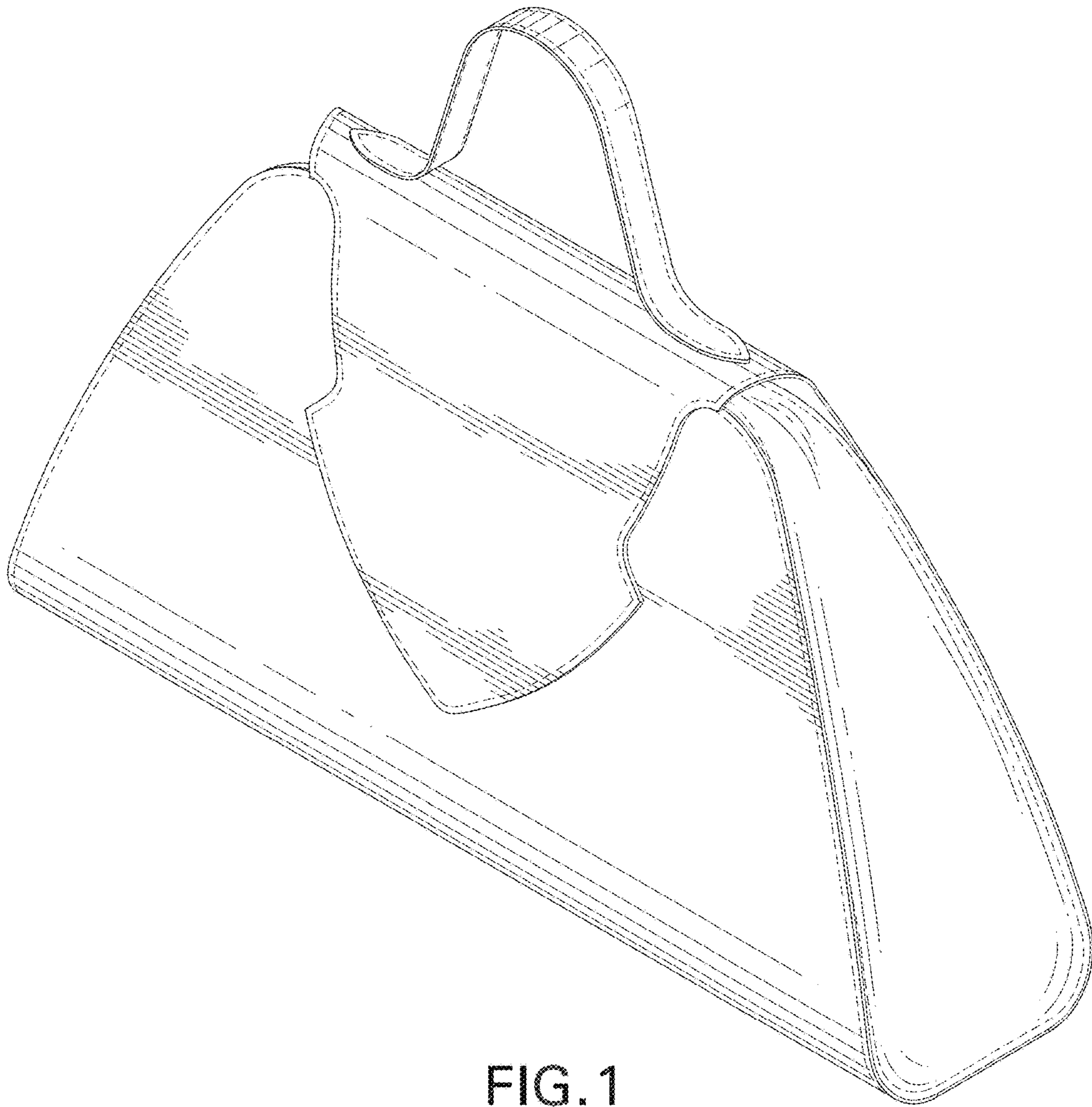

FIG. 1

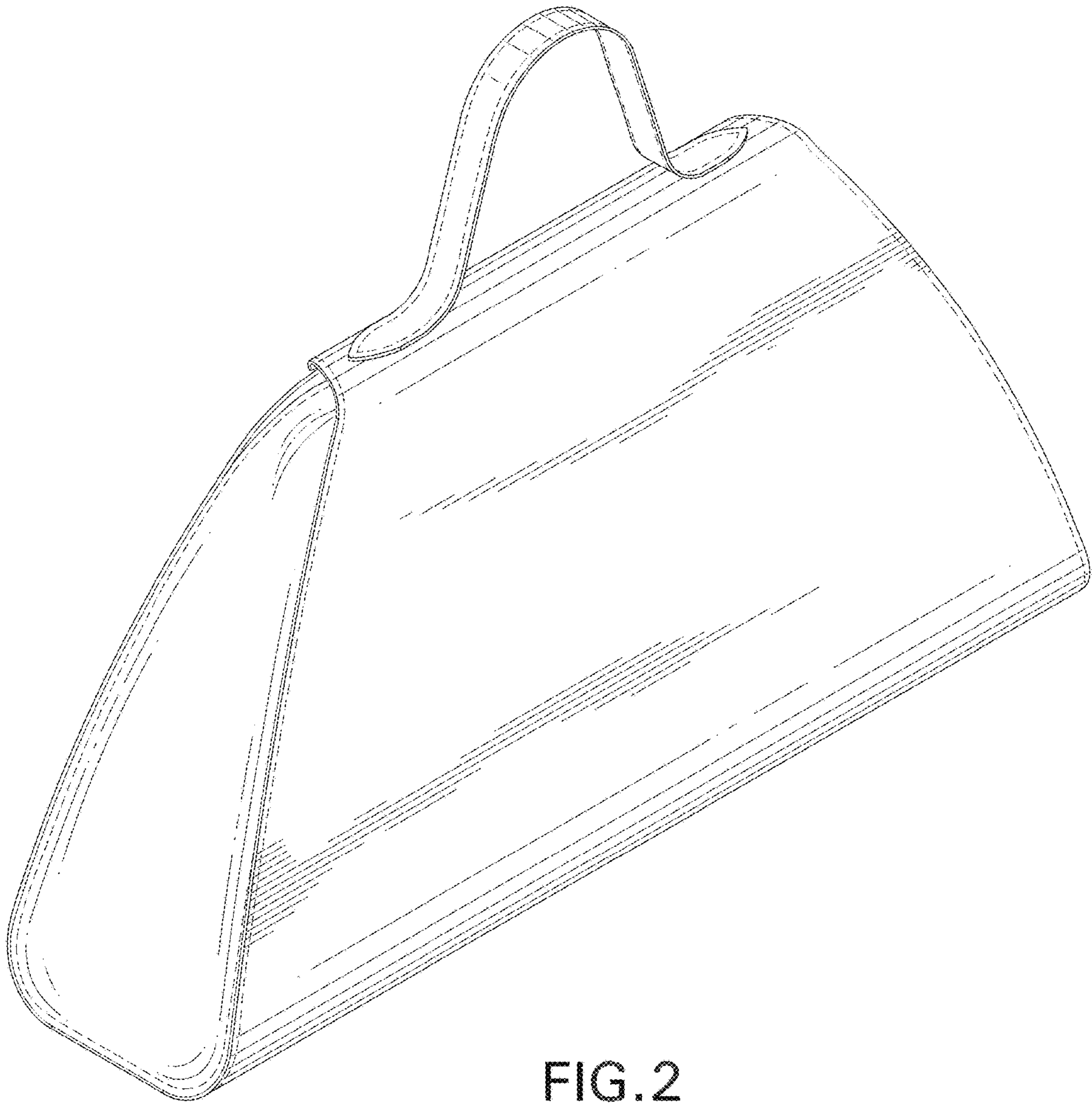

FIG. 2

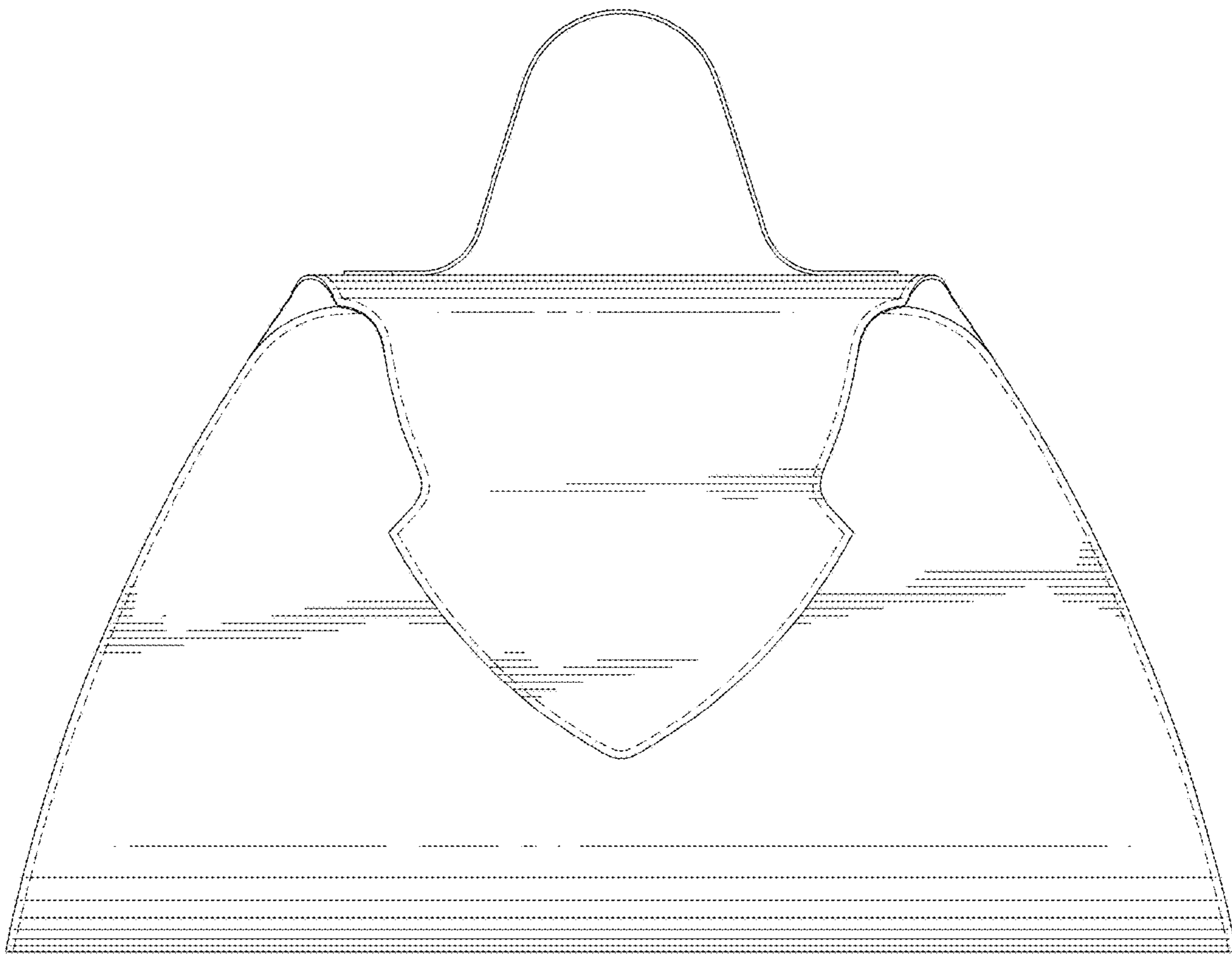

FIG. 3

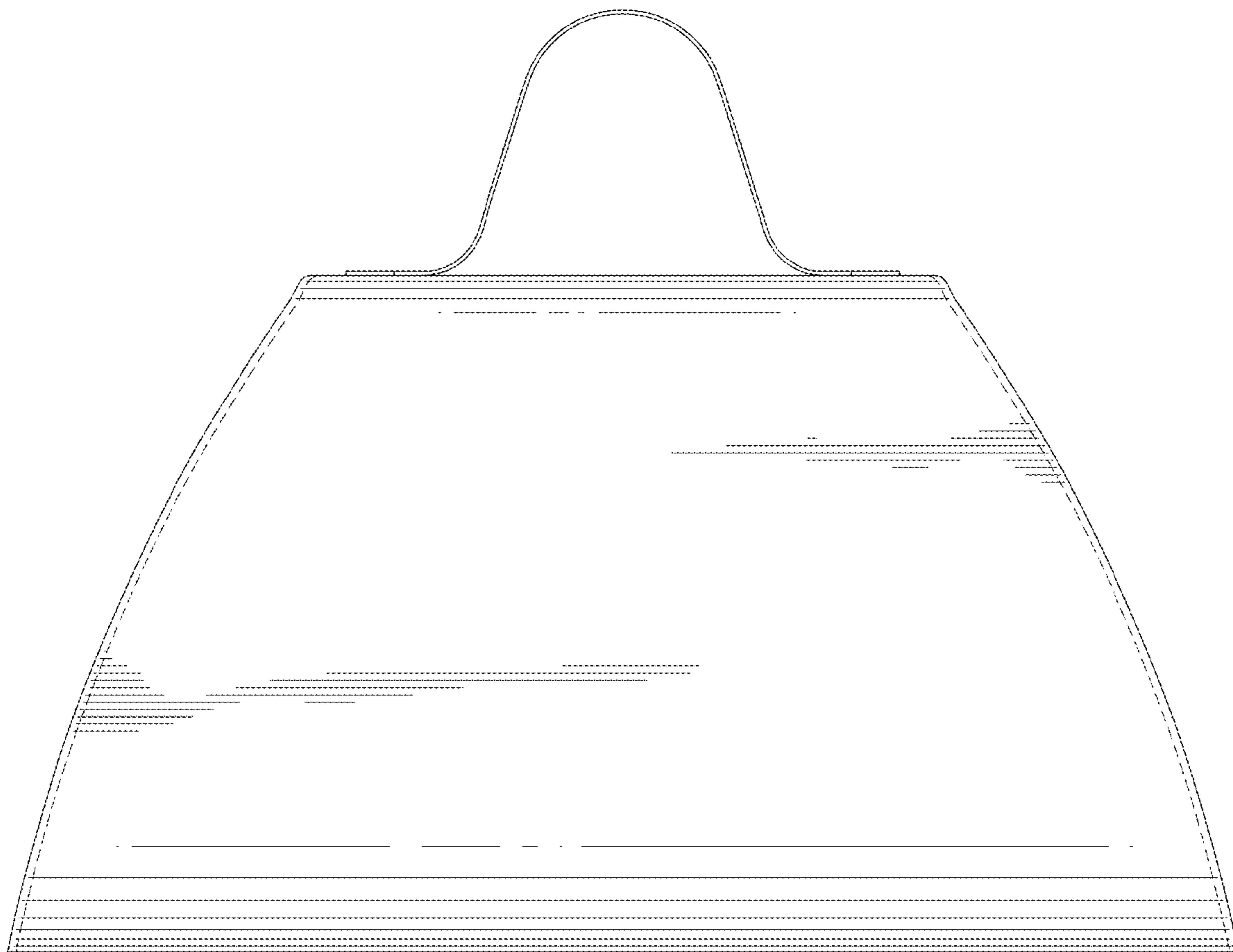

FIG. 4

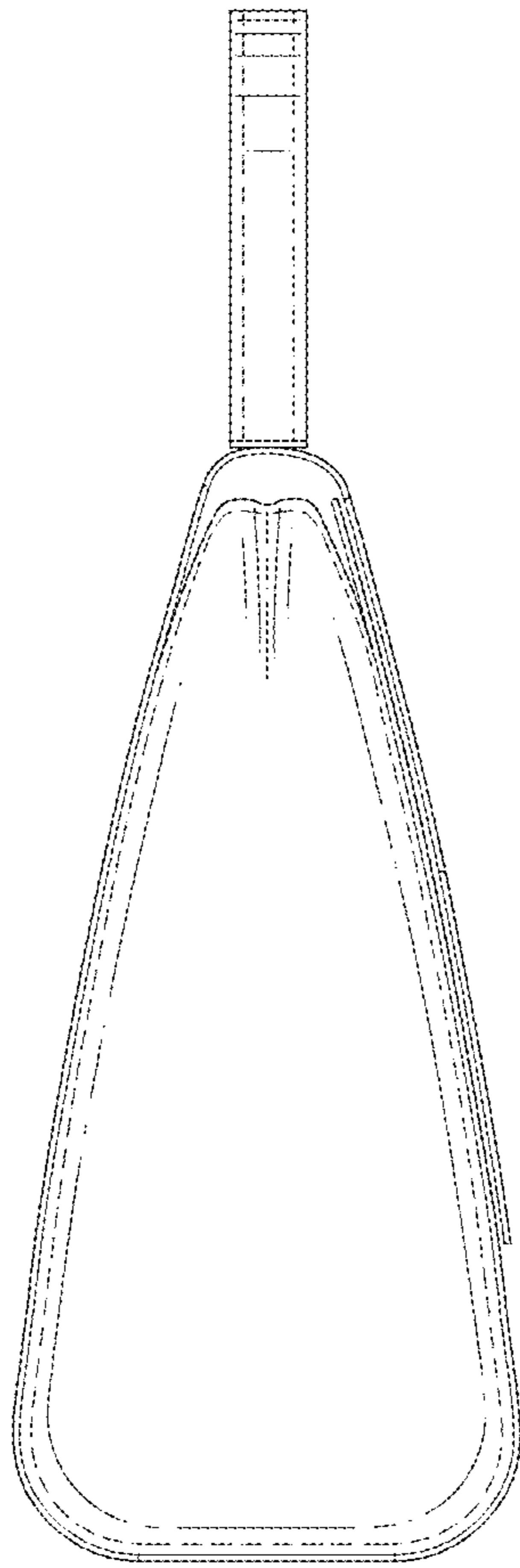

FIG. 5

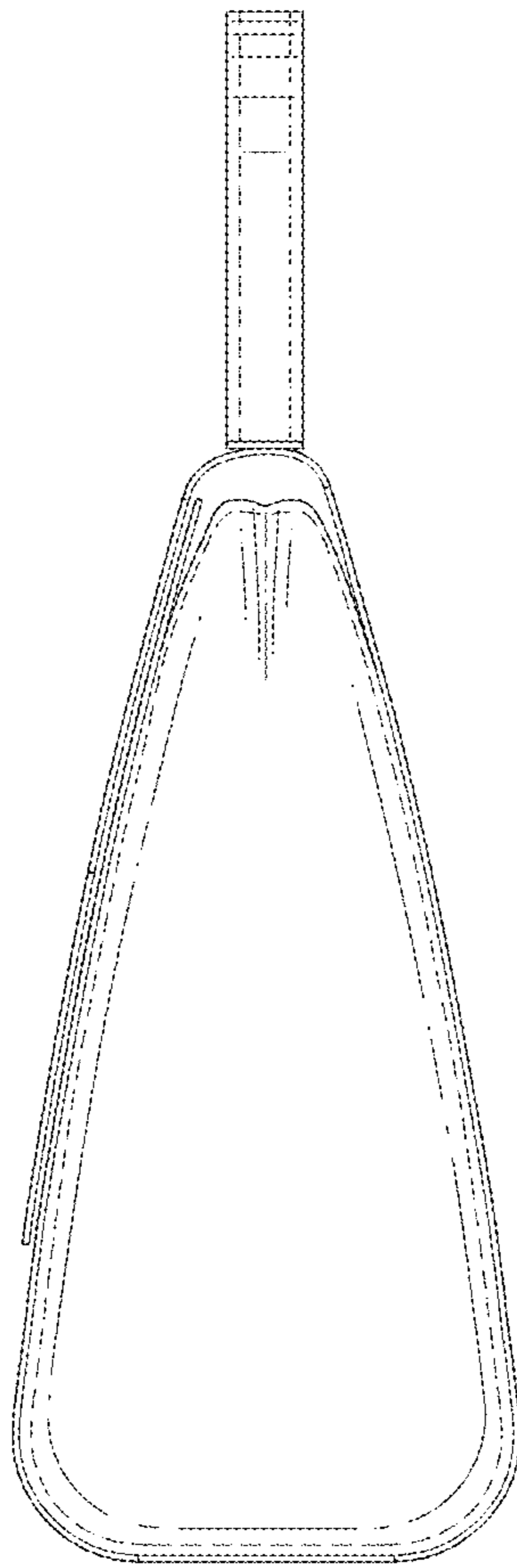

FIG. 6

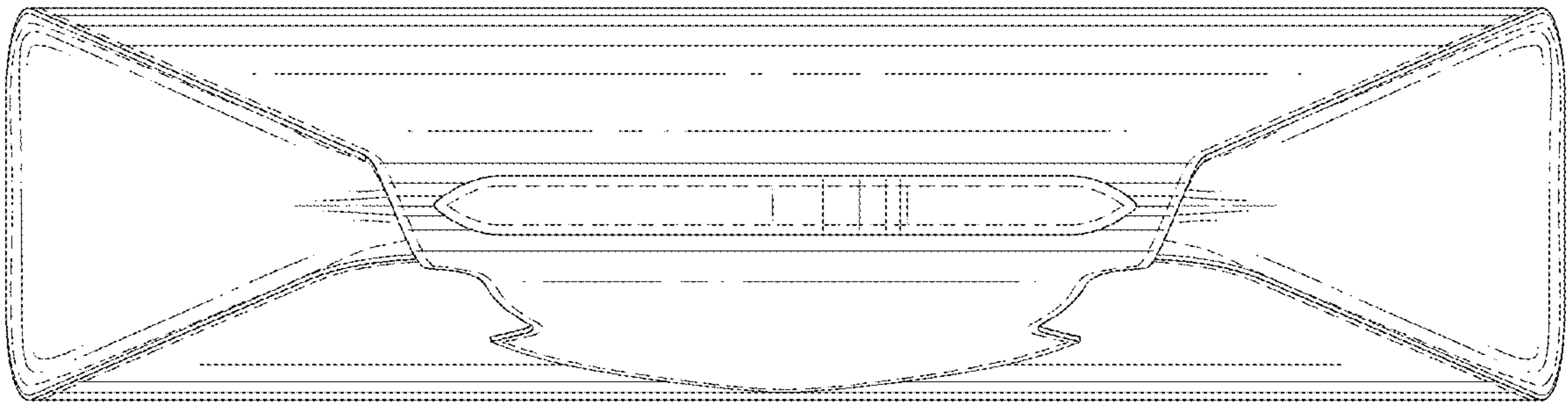

FIG. 7

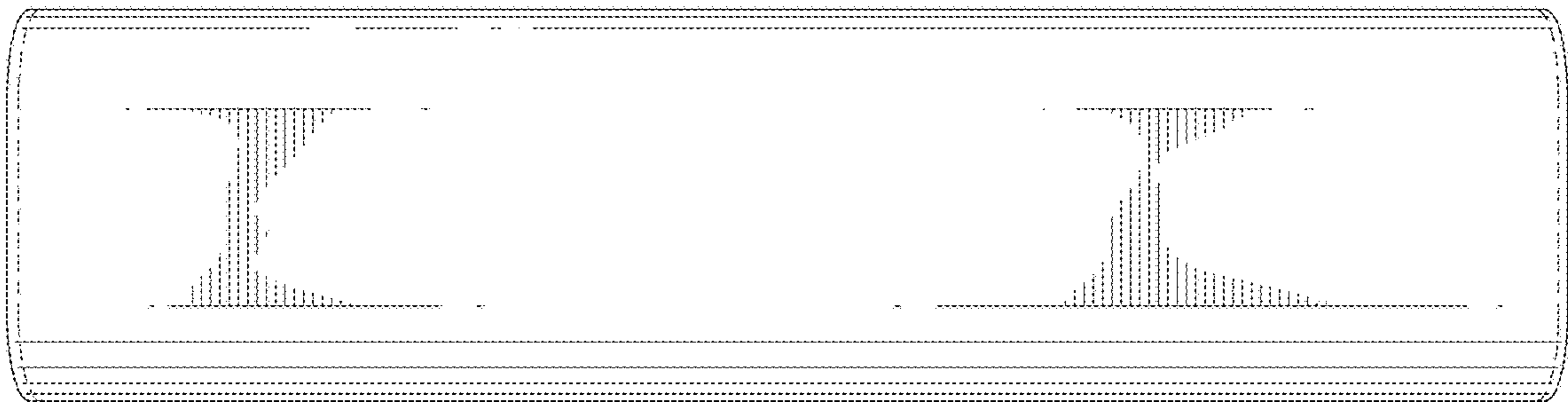

FIG. 8