



US00D811225S

(12) **United States Design Patent** (10) **Patent No.:** **US D811,225 S**
Newson (45) **Date of Patent:** **** Feb. 27, 2018**

(54) **PERFUME BOTTLE**

B65D 2501/0081; B65D 7/04; B65D 81/00

(71) Applicant: **Louis Vuitton Malletier**, Paris (FR)

See application file for complete search history.

(72) Inventor: **Marc Newson**, London (GB)

(56) **References Cited**

(73) Assignee: **LOUIS VUITTON MALLETIER**, Paris (FR)

U.S. PATENT DOCUMENTS

(**) Term: **15 Years**

283,825 A * 8/1883 Shepard G09F 3/04 215/382
D69,486 S * 2/1926 Braun D9/505
D98,270 S * 1/1936 McIntosh D9/544
D160,408 S * 10/1950 McIntosh D9/545
D430,291 S * 8/2000 Jansen D24/121
D431,648 S * 10/2000 Jansen D24/121

(21) Appl. No.: **29/566,580**

(Continued)

(22) Filed: **Jun. 1, 2016**

FOREIGN PATENT DOCUMENTS

(30) **Foreign Application Priority Data**

IE 22084-0001 * 8/2016

Dec. 18, 2015 (FR) 2015-6164

OTHER PUBLICATIONS

(51) **LOC (11) Cl.** **09-01**

Les Parfums Louis Vuitton: Turbulences, ilvoelv.com, posted Sep. 5, 2016, [online], [site visited Feb. 6, 2017]. Available from Internet, © 2017.ILVOELV. <URL: <http://www.ilvoely.com/2016/09/les-parfums-louis-vuitton-turbulences.html>>.*

(52) **U.S. Cl.**

USPC **D9/505**; D9/549; D9/439

(Continued)

(58) **Field of Classification Search**

USPC D9/434-435, 439, 447, 453, 448, 454, D9/500-505, 516, 520, 529-530, D9/537-542, 544-546, 549-550, 553, D9/556-558, 566, 574-575, 682, D9/685-692, 715, 719, 724, 763-783; D7/300, 300.1, 598, 509-511, 619.1, D7/619.2, 307, 308, 314, 315; D24/197; 215/378-379, 381-385, 370-371; 220/660, 662, 669-674, 675; 28/91.1

Primary Examiner — Anhdao Doan
Assistant Examiner — Mary Malley
(74) *Attorney, Agent, or Firm* — Finnegan, Henderson, Farabow, Garrett & Dunner LLP

(57) **CLAIM**

The ornamental design for a perfume bottle, as shown and described.

CPC ... B65D 1/00; B65D 1/02; B65D 1/12; B65D 1/14; B65D 1/16; B65D 1/40; B65D 1/44; B65D 1/023; B65D 1/0223; B65D 1/0233; B65D 1/165; B65D 1/238; B65D 1/246; B65D 1/253; B65D 23/00; B65D 83/00; B65D 2501/00; B65D 2501/0009;

DESCRIPTION

FIG. 1 is a top, perspective view of a perfume bottle showing my new design;
FIG. 2 is a front elevation view thereof;
FIG. 3 is a top plan view thereof;
FIG. 4 is a bottom plan view thereof;

(Continued)

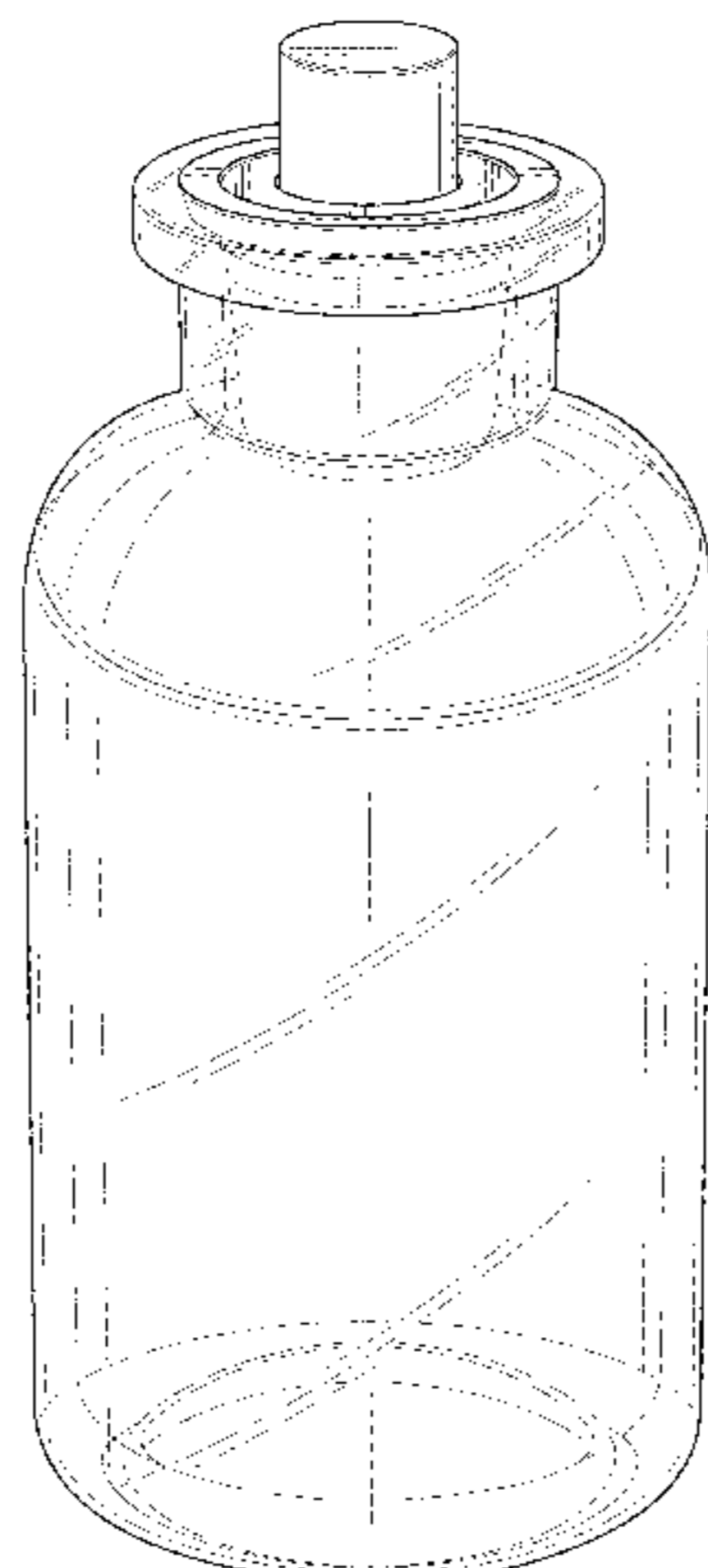

FIG. 5 is a top perspective view of the perfume bottle shown in an alternative configuration with the cap;
FIG. 6 is a front elevation view thereof;
FIG. 7 is a top plan view thereof; and,
FIG. 8 is a bottom plan view thereof.

1 Claim, 8 Drawing Sheets

(56)

References Cited

U.S. PATENT DOCUMENTS

D434,646 S * 12/2000 Gidlund D9/503
D447,561 S * 9/2001 Rudzena D24/121
D448,247 S * 9/2001 Hong D7/591
D489,620 S * 5/2004 Goodell D9/503
D511,461 S * 11/2005 Seys D9/522
D541,158 S * 4/2007 Herrmann D9/505

D633,389 S * 3/2011 Jorgensen D9/454
D695,131 S * 12/2013 Mansau D9/690
2013/0015193 A1 * 1/2013 Lien A63H 5/00
220/694

OTHER PUBLICATIONS

Model for a Perfume Bottle and Stopper, cmog.org, circa 1920-1930, [online], [site visited Feb. 3, 2017]. Available from Internet, © 2002—Corning Museum of Glass, <URL: <http://www.cmog.org/artwork/plaster-model-cylindrical-perfume-bottle-and-stopper>>.*
Vintage Apothecary Jars, etsy.com, posting date not given, [online], [site visited Feb. 6, 2017]. Available from Internet, © 2017 Etsy, <URL: <http://www.o-icatalogue.com.au/detail/product-15318https://www.etsy.com/listing/76986272/vintage-apothecary-jars-set-of-four>>.*
Set of 4 Antique amber Apothecary Bottles, etsy.com, posting date not given, [online], [site visited Feb. 6, 2017]. Available from Internet, © 2017 Etsy, <URL: <https://www.etsy.com/listing/96383820/set-of-4-antique-amber-apothecary>>.*

* cited by examiner

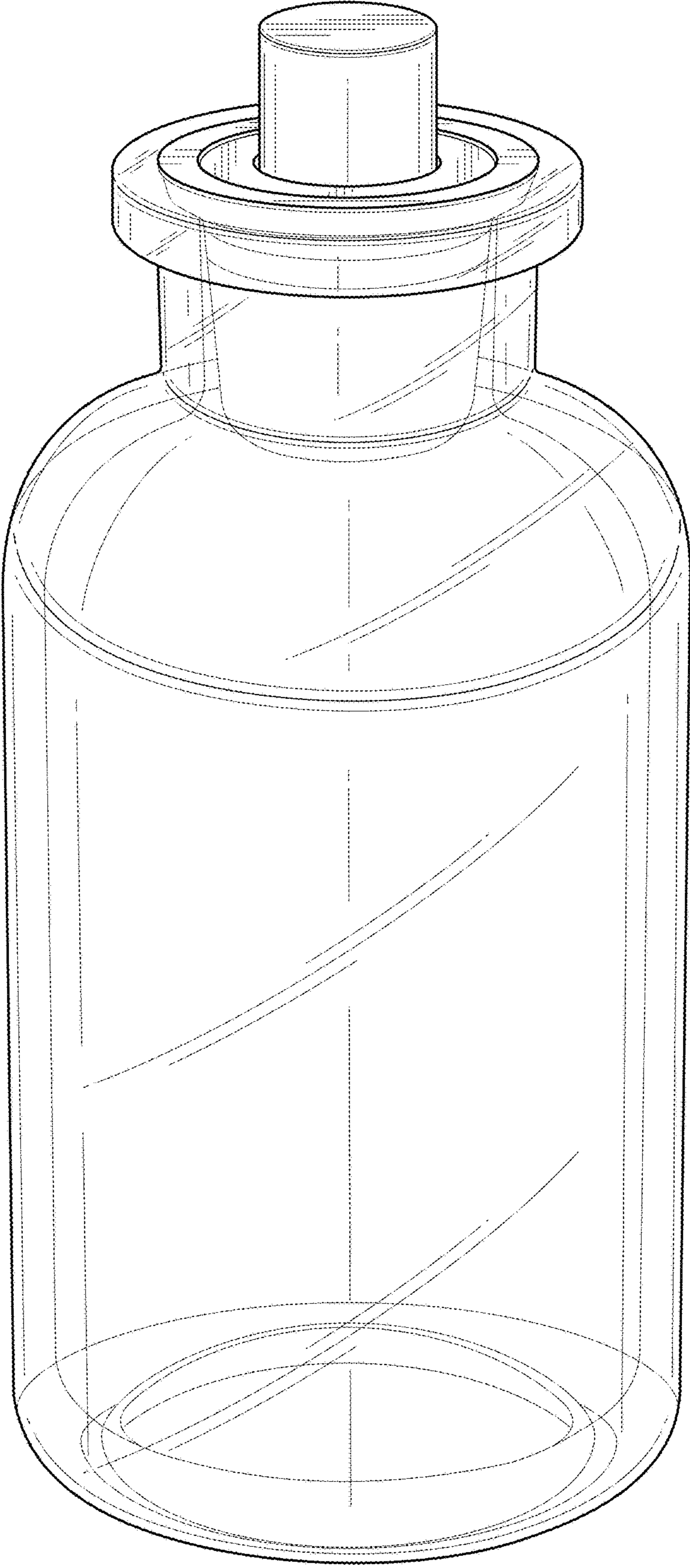

FIG. 1

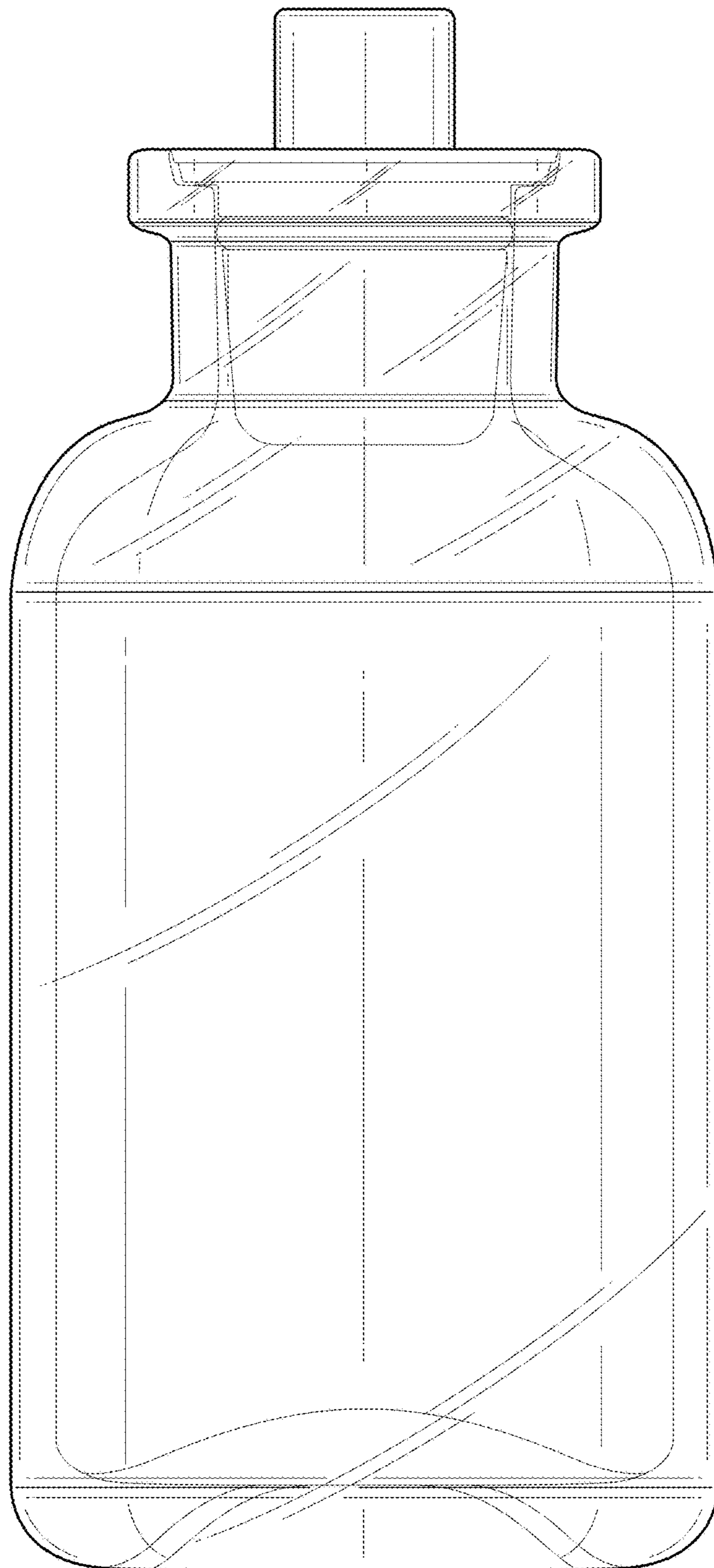

FIG. 2

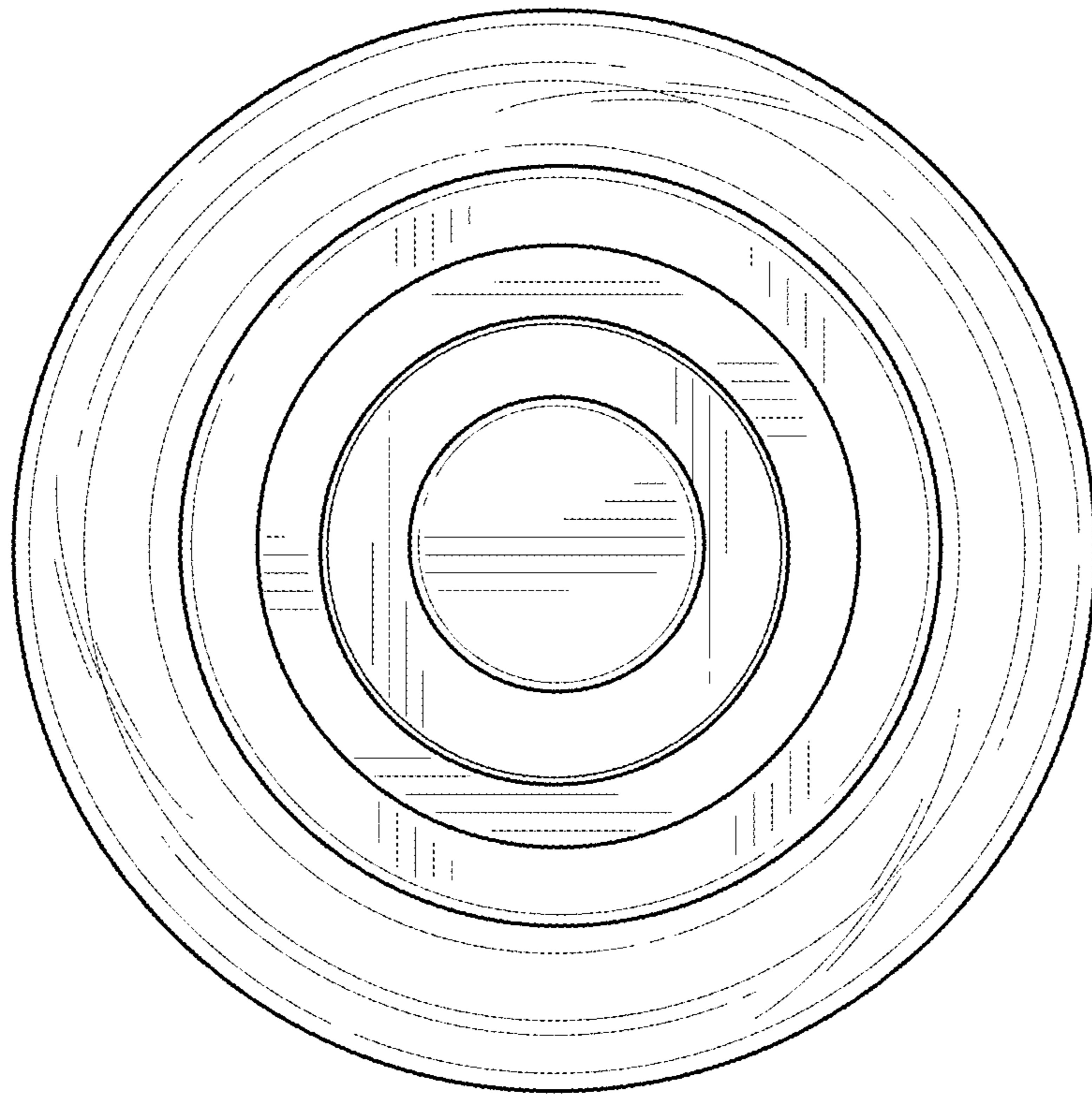

FIG. 3

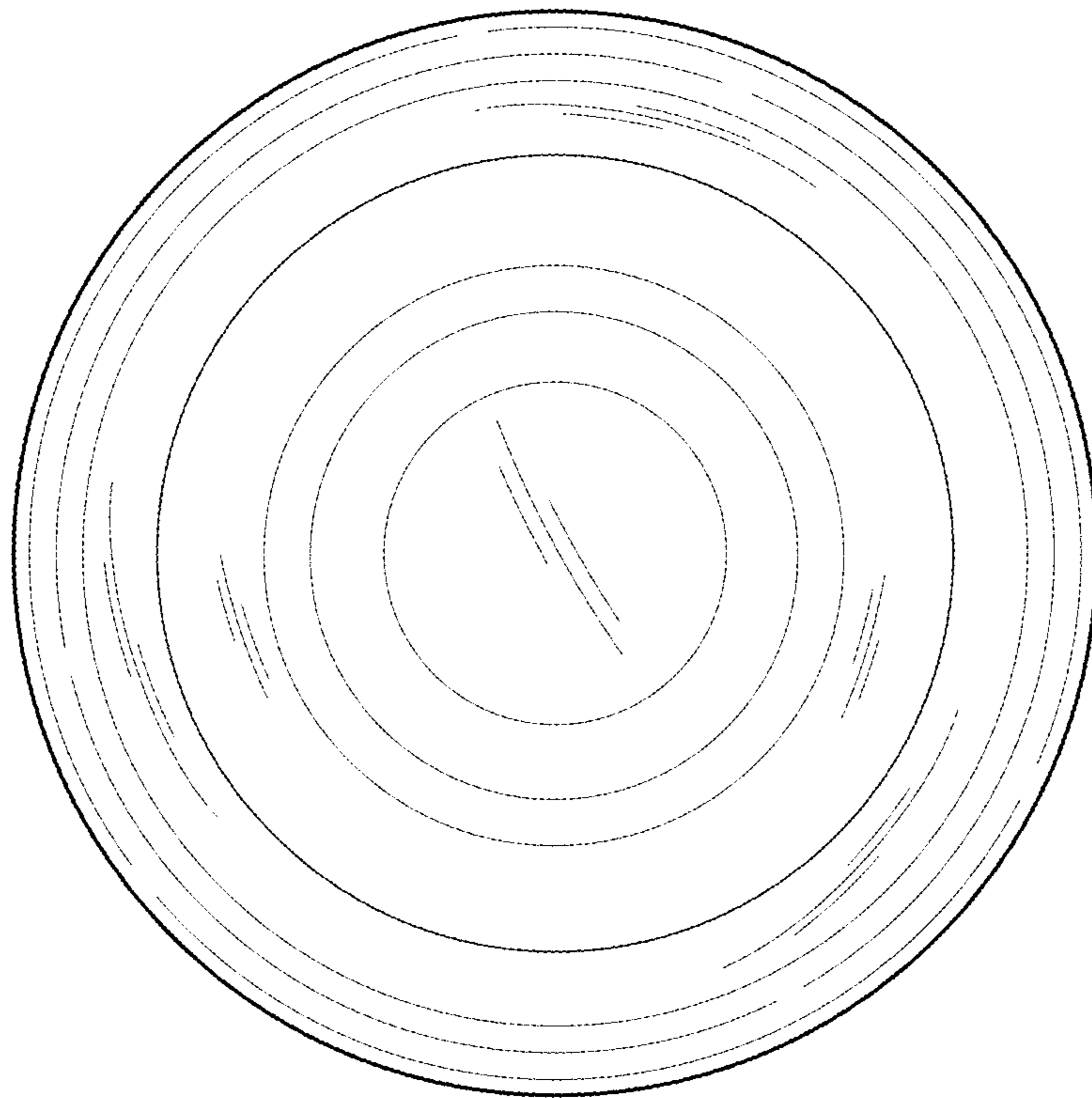

FIG. 4

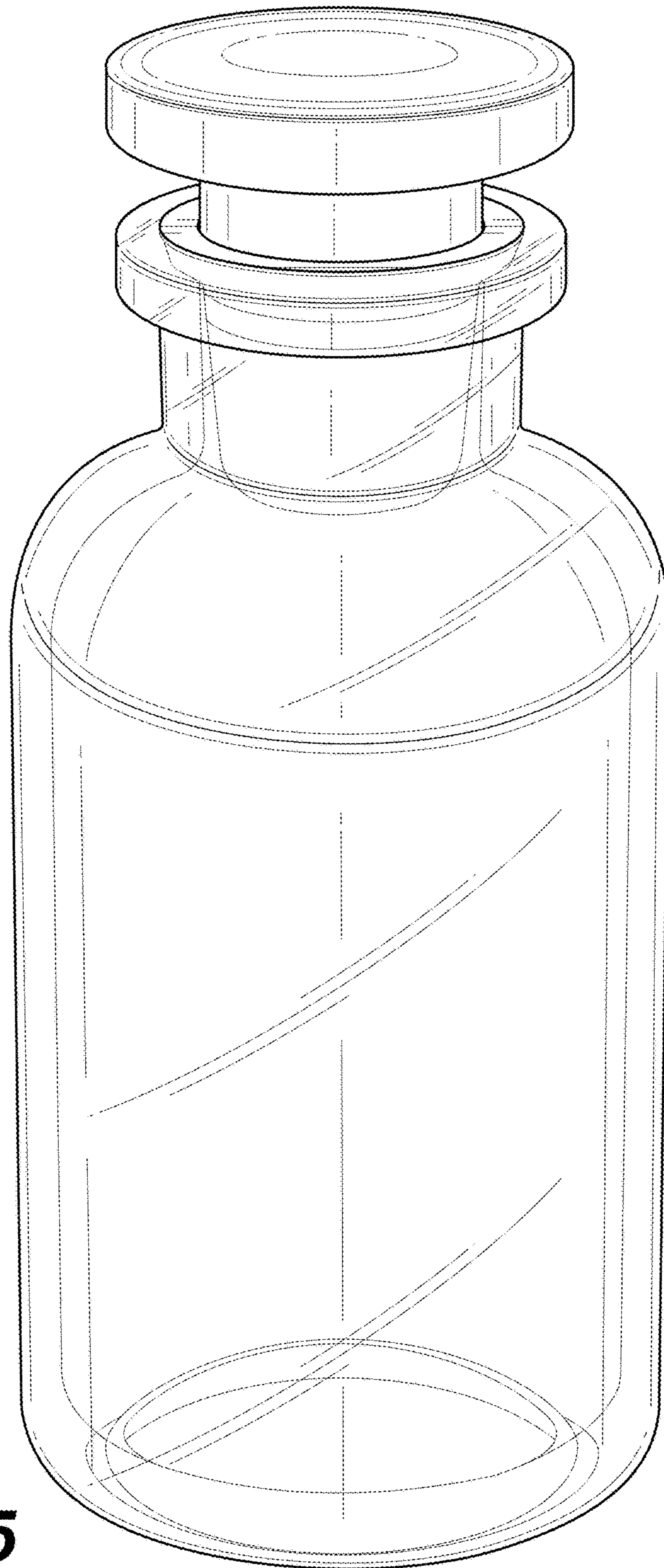

FIG. 5

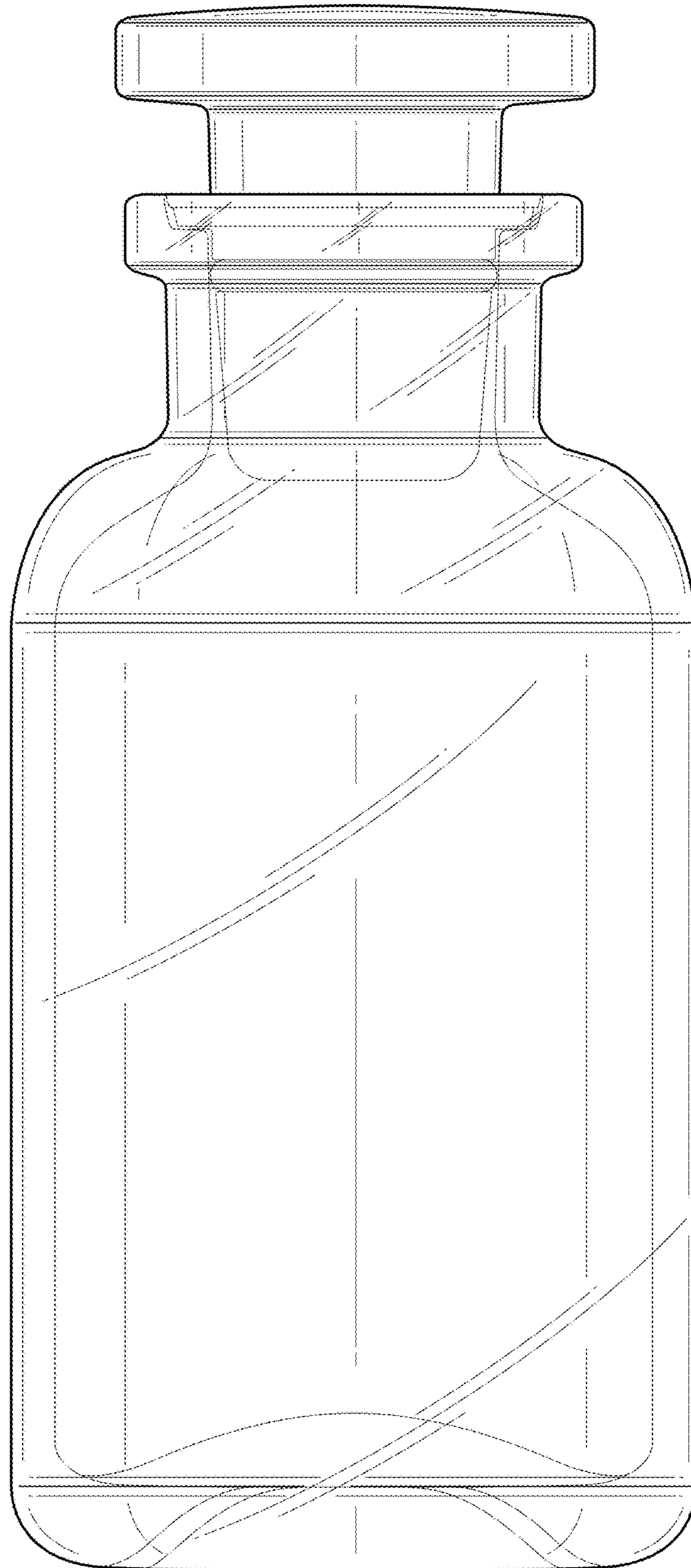

FIG. 6

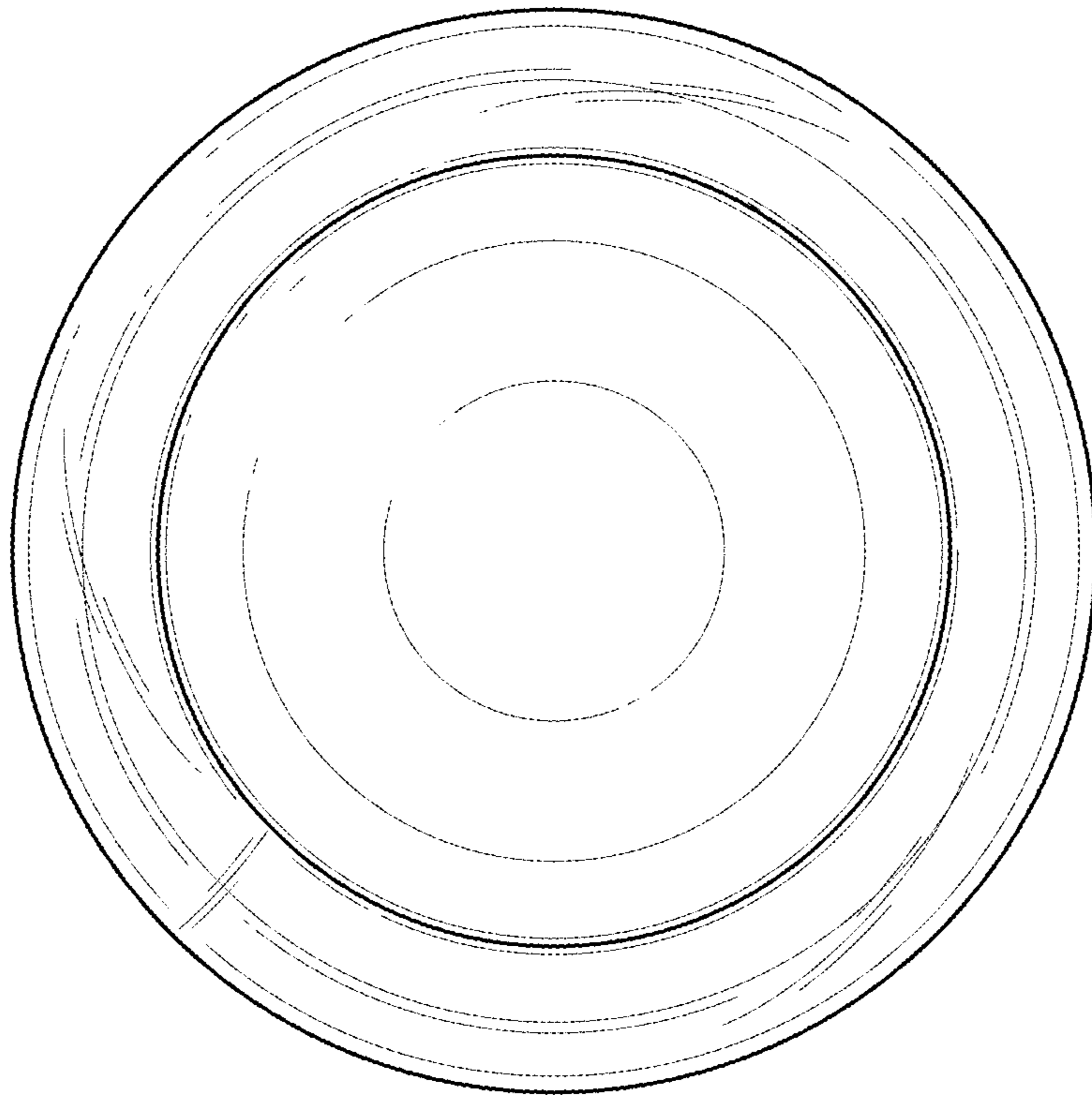

FIG. 7

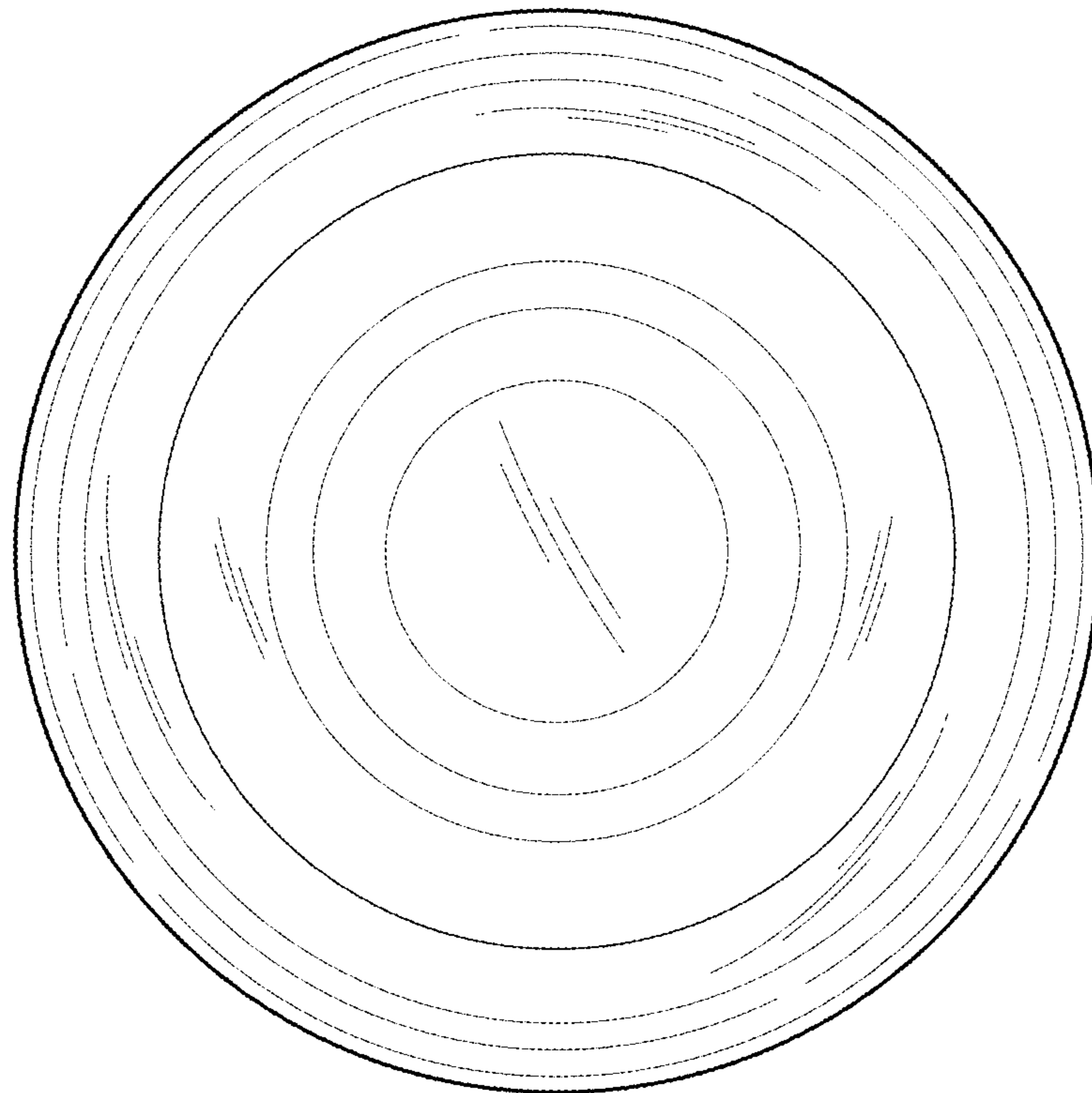

FIG. 8