



US00D811147S

(12) **United States Design Patent** (10) **Patent No.:** **US D811,147 S**
DeBaker (45) **Date of Patent:** **** Feb. 27, 2018**

(54) **BOTTLE FILL STATION** 2210/0006; B67D 2210/00065; B67D
2210/00076; B67D 2210/00081; B67D
(71) Applicant: **Saris Cycling Group, Inc.**, Madison, WI (US) 2210/00089; B67D 2210/00102; B67D
2210/0012; B67D 2210/00123; B67D
2210/00141; B67D 3/00351; B67D
3/0067;

(72) Inventor: **Chad DeBaker**, Minneapolis, MN (US)

(73) Assignee: **Saris Cycling Group, Inc.**, Madison, WI (US)

(Continued)

(**) Term: **15 Years**

(21) Appl. No.: **29/546,854**

(22) Filed: **Nov. 25, 2015**

(51) **LOC (11) Cl.** **07-01**

(52) **U.S. Cl.**
USPC **D7/300**

(58) **Field of Classification Search**
USPC D6/300, 672, 673, 694, 698, 699, 699.1,
D6/700; D7/300, 304, 306, 311, 312,
D7/313

CPC B01D 35/30; B67D 3/00; B67D 1/0888;
B67D 1/0021; B67D 1/0857; B67D
1/0884; B67D 1/0894; B67D 1/10; B67D
1/0041; B67D 1/0081; B67D 1/0801;
B67D 1/12; B67D 1/1279; B67D 1/00;
B67D 1/0043; B67D 1/0084; B67D 1/07;
B67D 1/0811; B67D 1/0004; B67D
1/0078; B67D 1/04; B67D 1/0406; B67D
1/0858; B67D 1/0865; B67D 1/0867;
B67D 1/0891; B67D 1/1247; B67D
1/0009; B67D 1/0014; B67D 1/0015;
B67D 1/0034; B67D 1/004; B67D
1/0044; B67D 1/005; B67D 1/0051;
B67D 1/0057; B67D 2001/0827; B67D
2001/0812; B67D 2001/0089; B67D
2001/0093; B67D 2001/0094; B67D
2001/075; B67D 2001/082; B67D
2001/0821; B67D 2001/0822; B67D
2001/0828; B67D 2001/1483; B67D
2210/00015; B67D 2210/00031; B67D
2210/00034; B67D 2210/0001; B67D
2210/00013; B67D 2210/00041; B67D

(56) **References Cited**

U.S. PATENT DOCUMENTS

D143,887 S * 2/1946 Thompson D7/307
D241,747 S * 10/1976 King D25/16

(Continued)

OTHER PUBLICATIONS

Bottle Fill Station, [online], [site visited Oct. 4, 2016]. Available from Internet, <URL:http://www.bikefixtation.com/products/bottle-fill-station.html>.*

Primary Examiner — Caron D Veynar

Assistant Examiner — Katrina N Gonzalez

(74) *Attorney, Agent, or Firm* — Boyle Fredrickson, S.C.

(57) **CLAIM**

The ornamental design for a bottle fill station, as shown and described.

DESCRIPTION

FIG. 1 is a front, right perspective view of the bottle fill station, showing the new design;
FIG. 2 is a rear, right perspective view thereof;
FIG. 3 is a front view thereof;
FIG. 4 is a back view thereof;
FIG. 5 is a top view thereof;
FIG. 6 is a bottom view thereof;
FIG. 7 is a right side view thereof; and,
FIG. 8 is a left side view thereof.

(Continued)

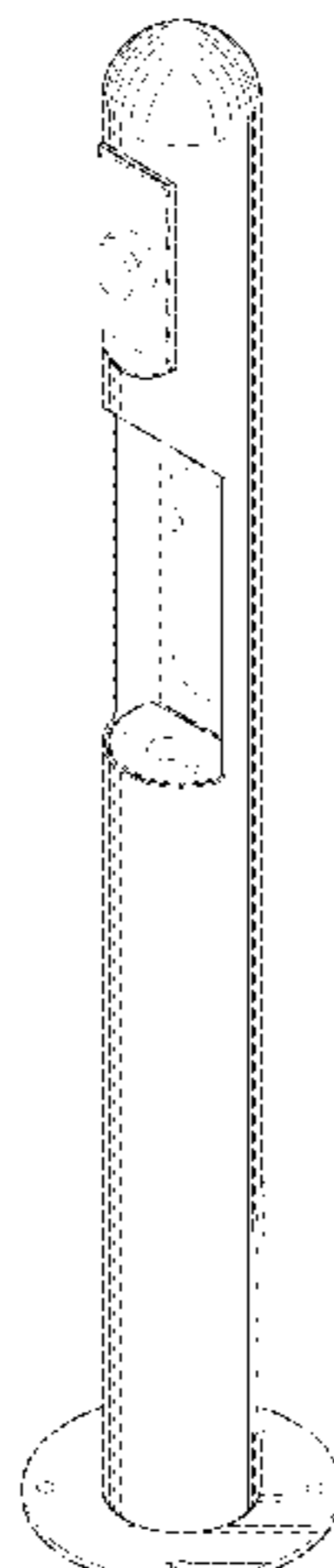

The broken lines are shown for the purpose of illustrating parts of the bottle fill station that form no part of the claim.

1 Claim, 4 Drawing Sheets

(58) **Field of Classification Search**

CPC . B67D 3/0006; B67D 3/0009; B67D 3/0019;
B67D 3/0061; B67D 3/0077; B67D
3/0012; B67D 3/0032; B67D 3/0038;
B67D 3/0051; B67D 3/007; B67D 3/008;
B67D 3/0096; B67D 3/02; B67D 3/04;
B67D 7/06; B67D 7/74; B67D 7/76;
B67D 7/78; B67D 7/84

See application file for complete search history.

(56) **References Cited**

U.S. PATENT DOCUMENTS

D264,277 S * 5/1982 Poelvoorde D6/672
D341,746 S * 11/1993 Stillson D20/4
D364,305 S * 11/1995 Rasmussen D7/300
5,553,751 A * 9/1996 Mowers B67D 3/00
222/183
D408,207 S * 4/1999 Bourke D7/300

D449,758 S * 10/2001 Norvell D7/300
D456,663 S * 5/2002 Chew D7/306
D457,773 S * 5/2002 John D7/300
D482,227 S * 11/2003 Walton D7/306
6,708,848 B2 * 3/2004 Sheridan B67D 3/0029
222/146.6
D495,914 S * 9/2004 Drolette, Jr. D7/306
D588,576 S * 3/2009 Son D14/211
D588,852 S * 3/2009 Stein D7/301
D600,060 S * 9/2009 Fletcher D7/306
D640,891 S * 7/2011 Smith D7/307
D644,471 S * 9/2011 Fiori D7/306
D652,668 S * 1/2012 Wang D7/306
D668,903 S * 10/2012 Walton D7/306
D671,346 S * 11/2012 Zlatic D23/208
D677,102 S * 3/2013 Walton D7/306
D687,810 S * 8/2013 Son D14/210
D687,812 S * 8/2013 Lee D14/211
D697,748 S * 1/2014 Wang D7/306
D702,475 S * 4/2014 Dalton D7/306
D721,582 S * 1/2015 Son D9/448
D734,086 S * 7/2015 Tseng D7/306
D734,635 S * 7/2015 Behar D7/306
D766,211 S * 9/2016 Choi D14/211
2012/0132673 A1 * 5/2012 Leyva B67D 1/0868
222/146.6
2016/0194192 A1 * 7/2016 Grottini B67D 3/0006
141/98

* cited by examiner

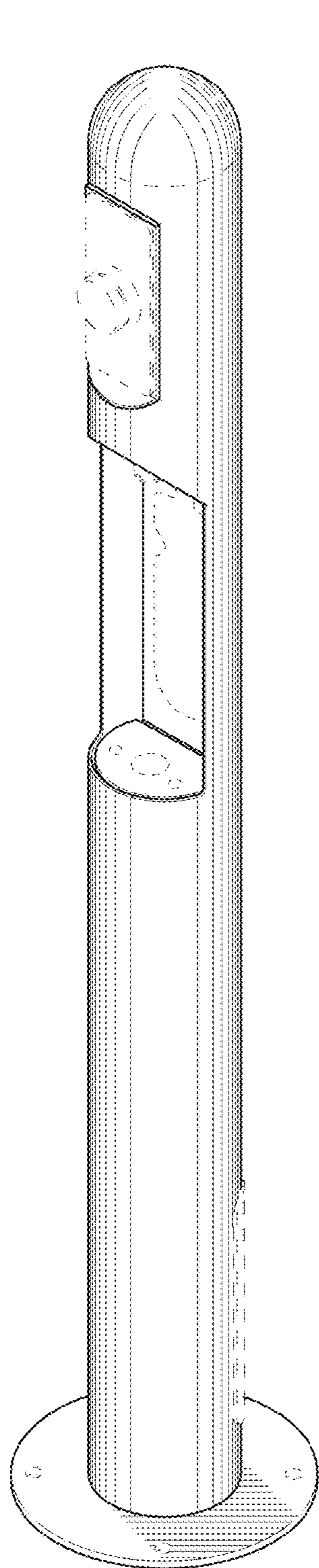

FIG. 1

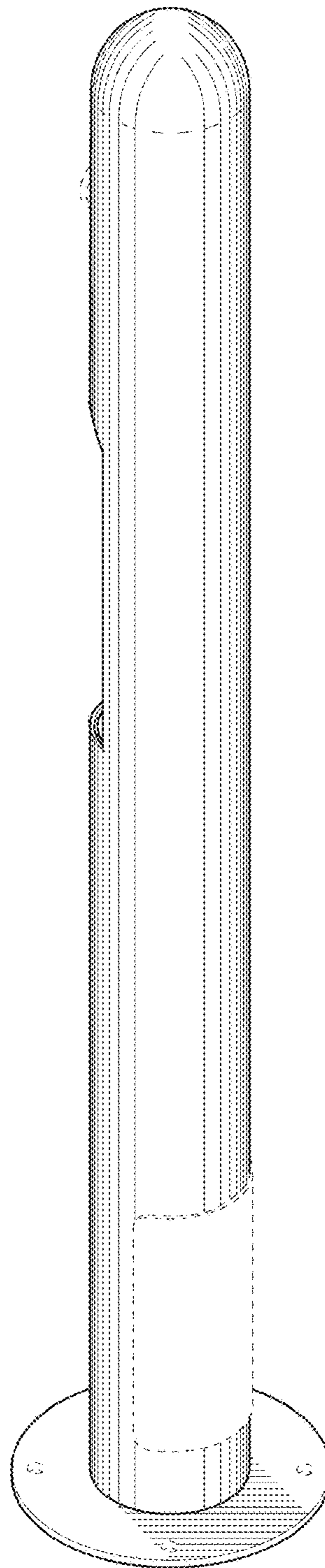

FIG. 2

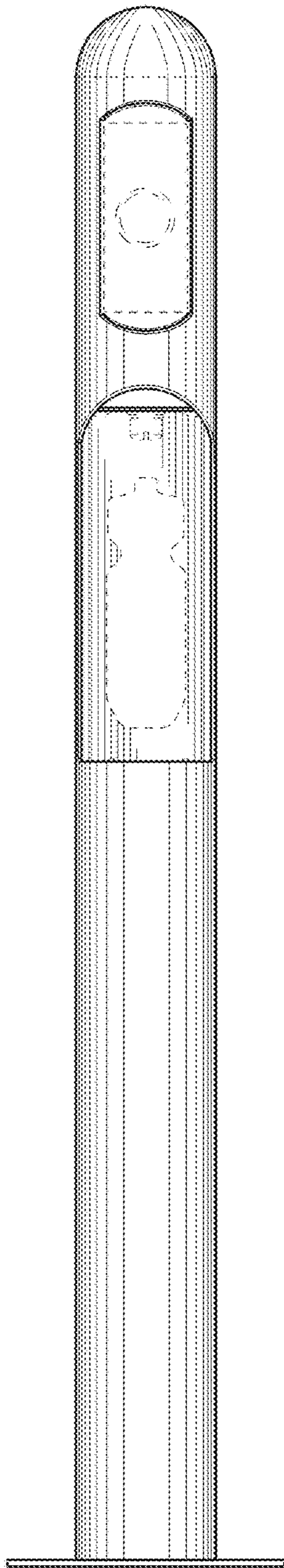

FIG. 3

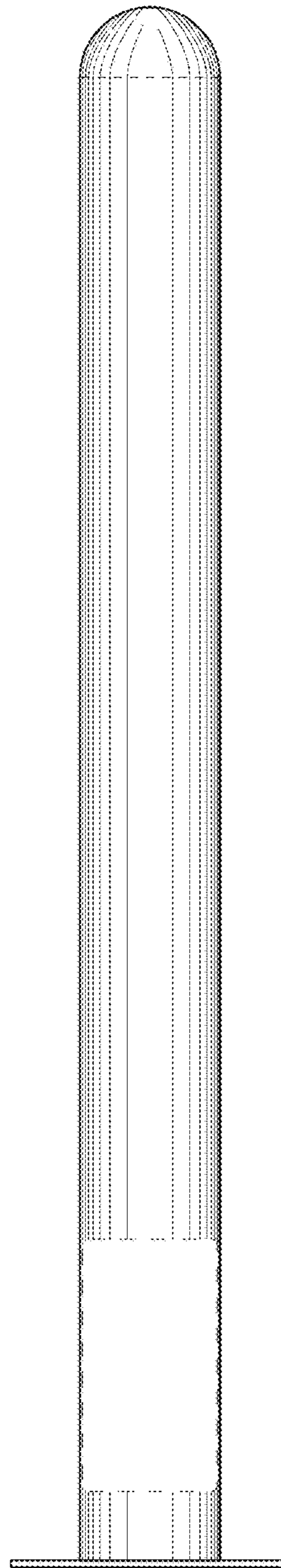

FIG. 4

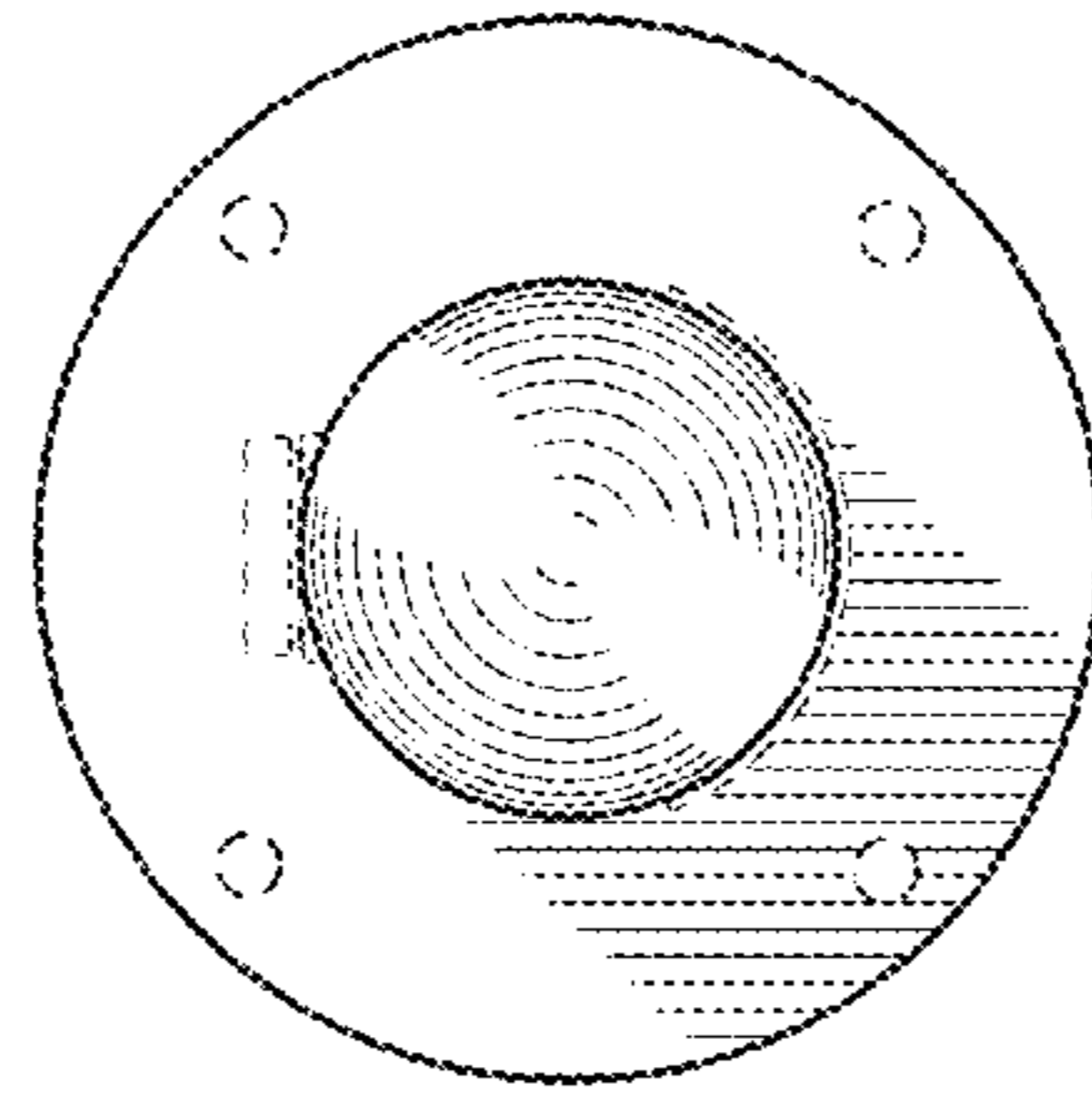

FIG. 5

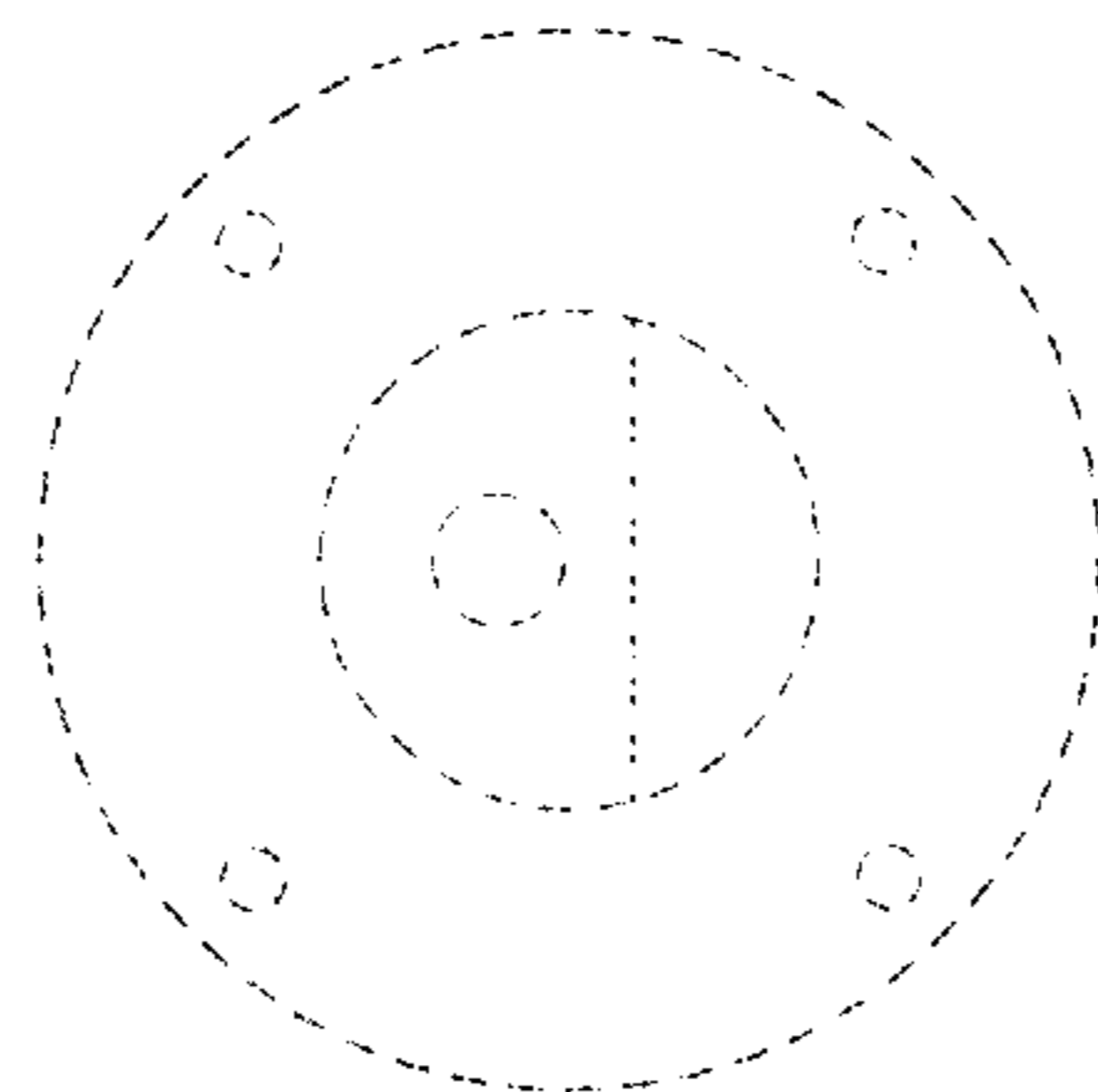

FIG. 6

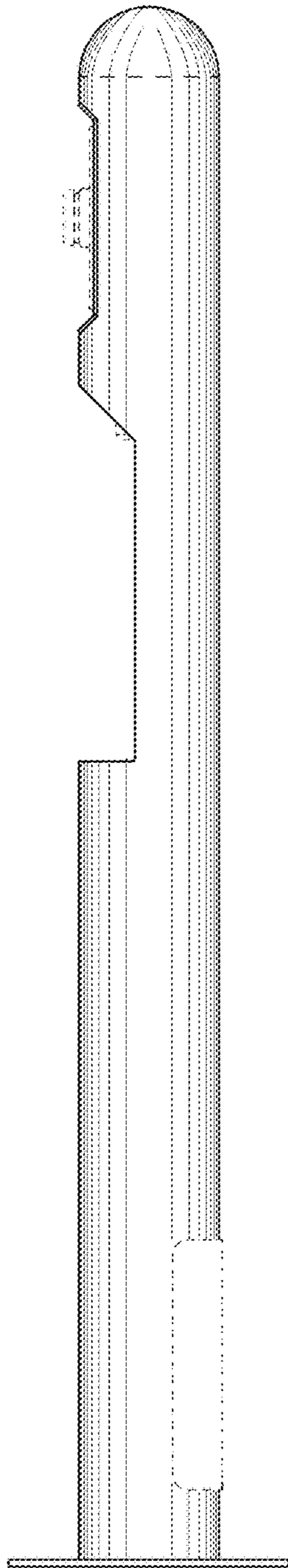

FIG. 7

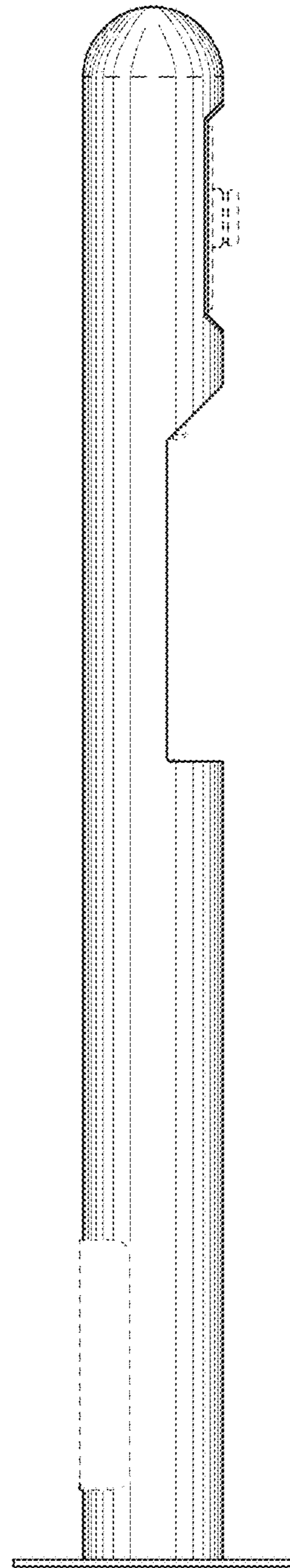

FIG. 8