



US00D810643S

(12) **United States Design Patent** (10) **Patent No.:** **US D810,643 S**
Takamura et al. (45) **Date of Patent:** **** Feb. 20, 2018**

(54) **INSTRUMENT PANEL FOR AN AUTOMOBILE**
(71) Applicant: **HONDA MOTOR CO., LTD.**, Tokyo (JP)
(72) Inventors: **Yuki Takamura**, Wako (JP); **Yosuke Shimizu**, Wako (JP)
(73) Assignee: **HONDA MOTOR CO., LTD.**, Tokyo (JP)
(**) Term: **15 Years**

(21) Appl. No.: **29/598,659**
(22) Filed: **Mar. 28, 2017**

(30) **Foreign Application Priority Data**
Sep. 30, 2016 (JP) 2016-021112
(51) **LOC (11) Cl.** **12-16**
(52) **U.S. Cl.**
USPC **D12/192**
(58) **Field of Classification Search**
USPC D12/192, 415, 110, 114; D15/17, 28; D10/46, 98, 102-103, 122-127
CPC G08G 1/096883; G01C 21/16; G01C 21/3688; G01C 21/30
See application file for complete search history.

(56) **References Cited**
U.S. PATENT DOCUMENTS
D762,152 S * 7/2016 Inagaki D12/192
D763,154 S * 8/2016 Chang D12/192
D763,155 S * 8/2016 Sahs D12/192
D770,348 S * 11/2016 Shimizu D12/192

D770,953 S * 11/2016 Tanaka D12/192
D771,541 S * 11/2016 Shouno D12/192
D776,029 S * 1/2017 Callum D12/192
D778,796 S * 2/2017 Gommier D12/192
D780,649 S * 3/2017 Tanaka D12/192
D793,931 S * 8/2017 Lee D12/192
D795,145 S * 8/2017 Miyashita D12/192
D795,146 S * 8/2017 Ogawa D12/192

* cited by examiner
Primary Examiner — Katrina A Betton
(74) *Attorney, Agent, or Firm* — Westerman, Hattori, Daniels & Adrian

(57) **CLAIM**
The ornamental design for an instrument panel for an automobile, as shown and described herein.

DESCRIPTION
FIG. 1 is a left side perspective view of an instrument panel for an automobile.
FIG. 2 is a right side perspective view of an instrument panel for an automobile.
FIG. 3 is a front view of an instrument panel for an automobile.
FIG. 4 is a top plan view of an instrument panel for an automobile.
FIG. 5 is a left side view of an instrument panel for an automobile; and
FIG. 6 is a right side view of an instrument panel for an automobile.
The broken lines in the drawings illustrate portions of the instrument panel for an automobile that form no part of the claimed design.

1 Claim, 6 Drawing Sheets

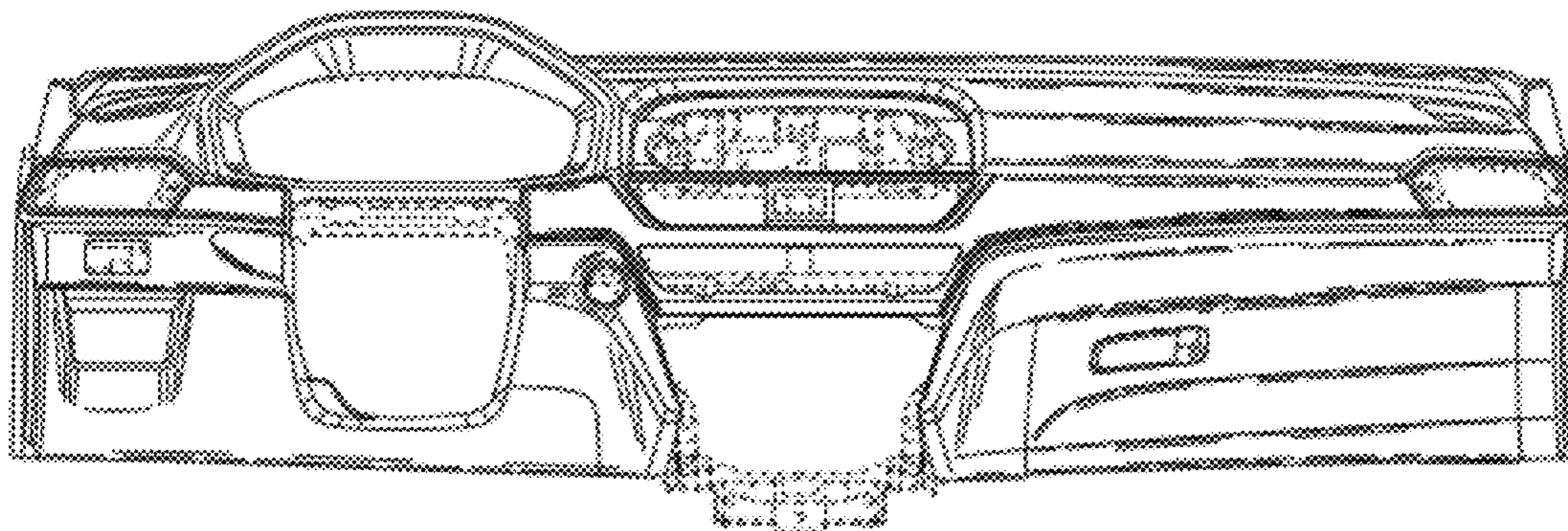

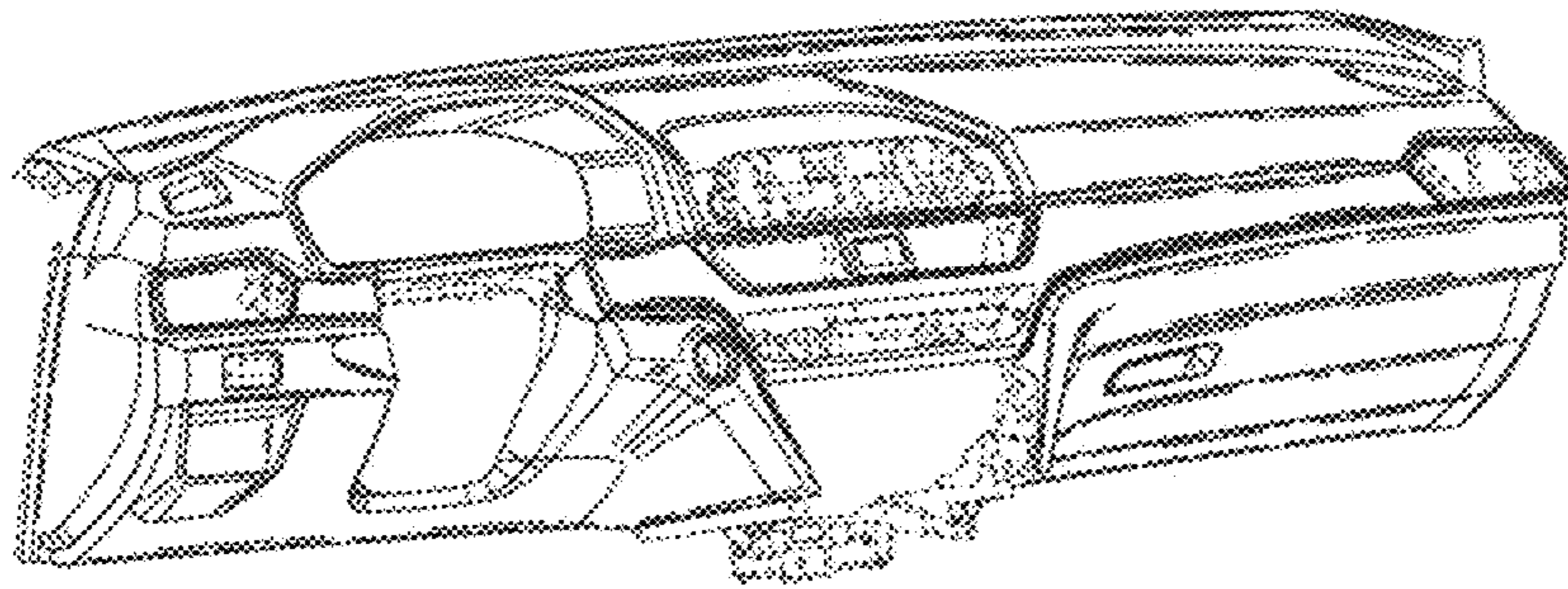

FIG.1

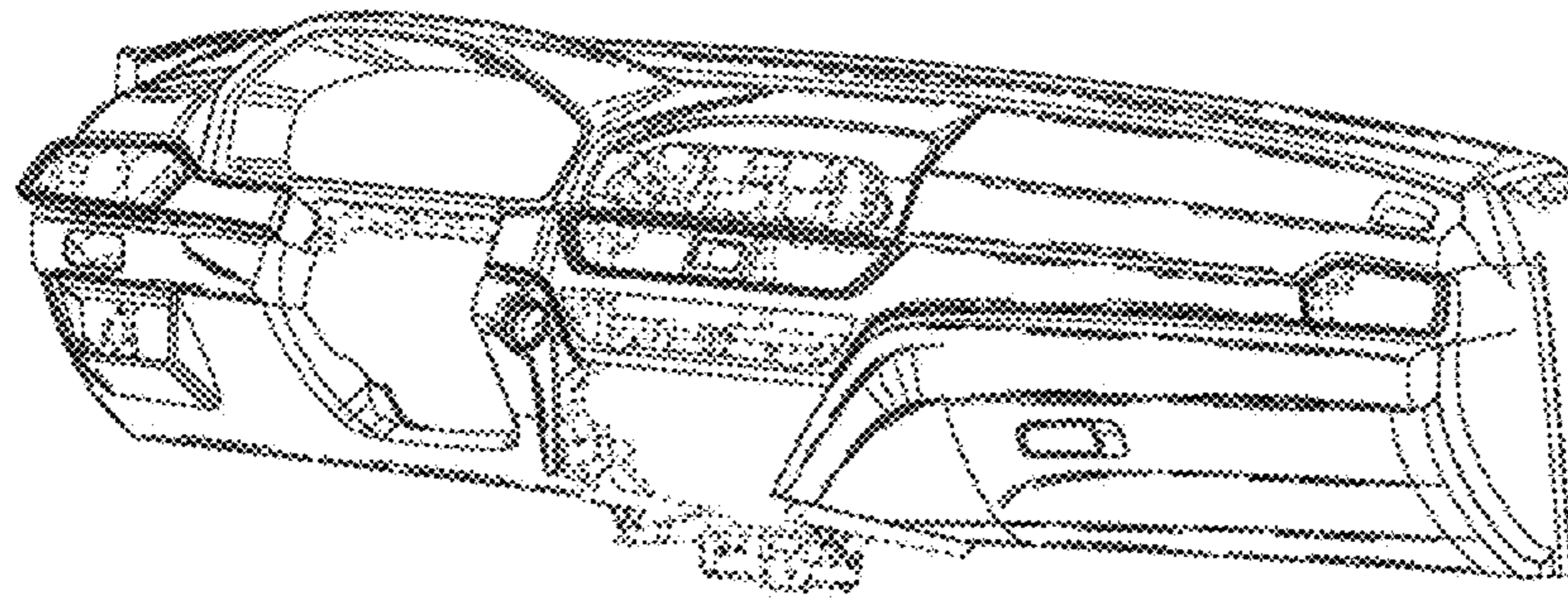

FIG.2

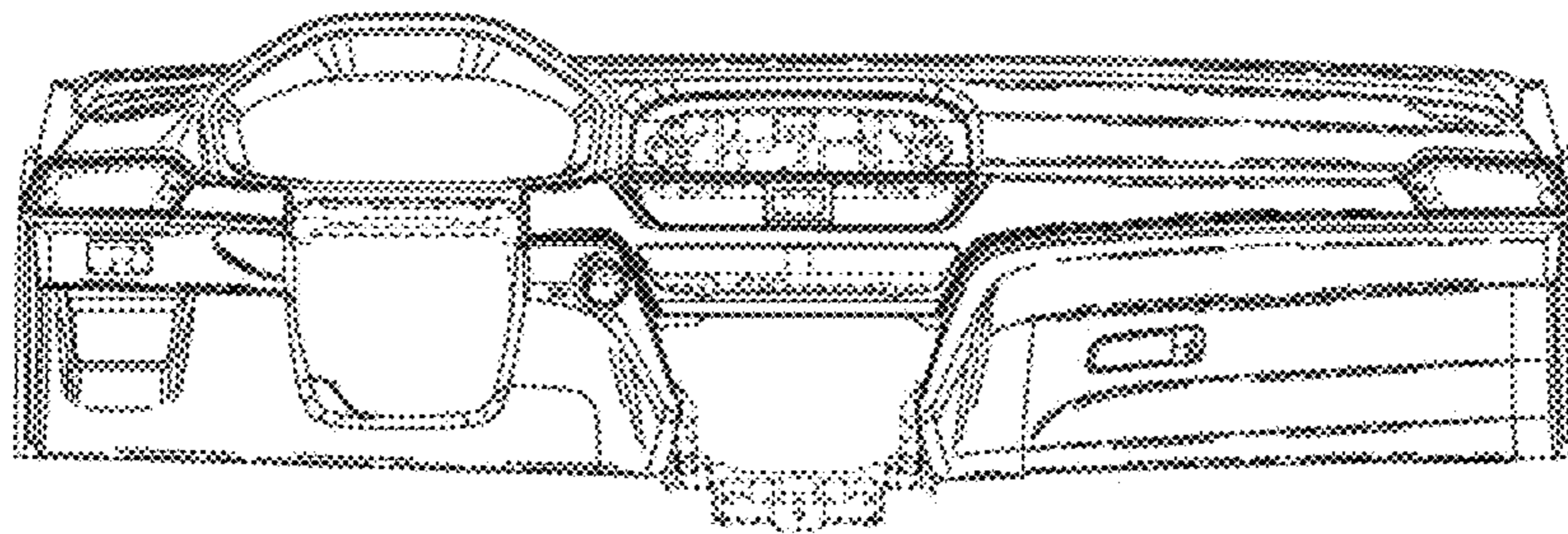

FIG.3

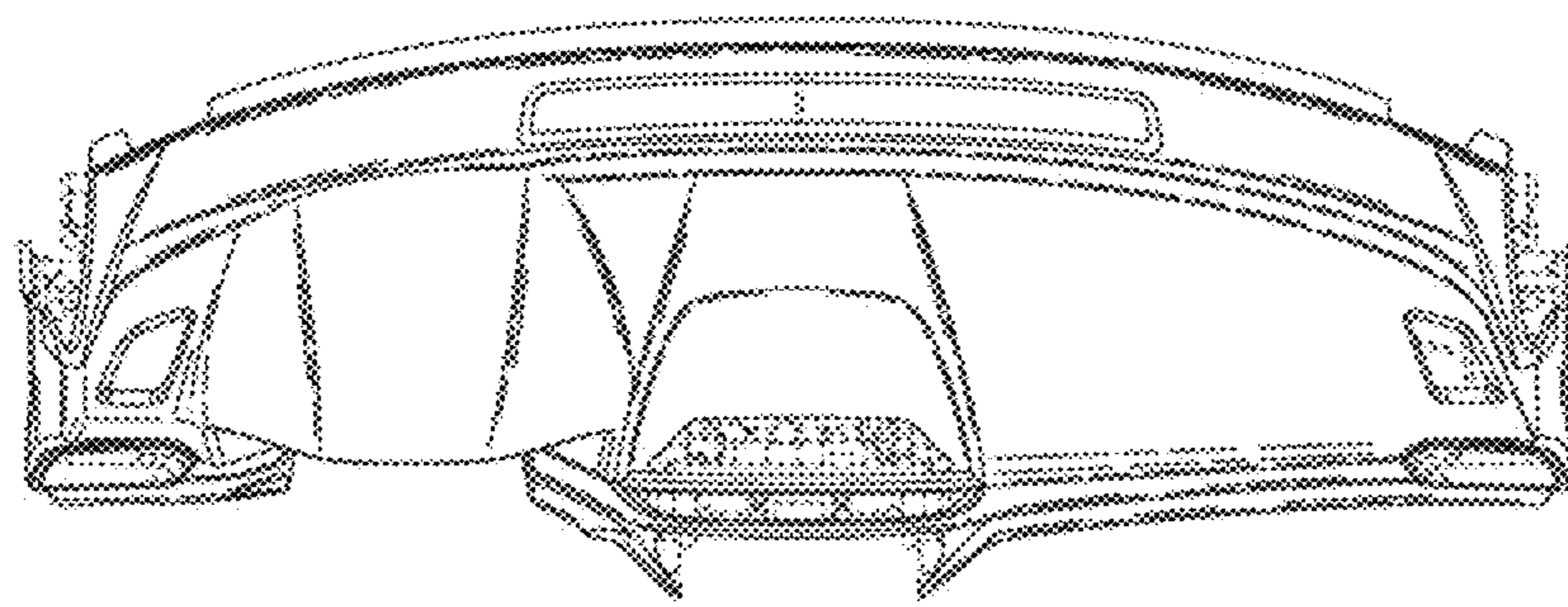

FIG.4

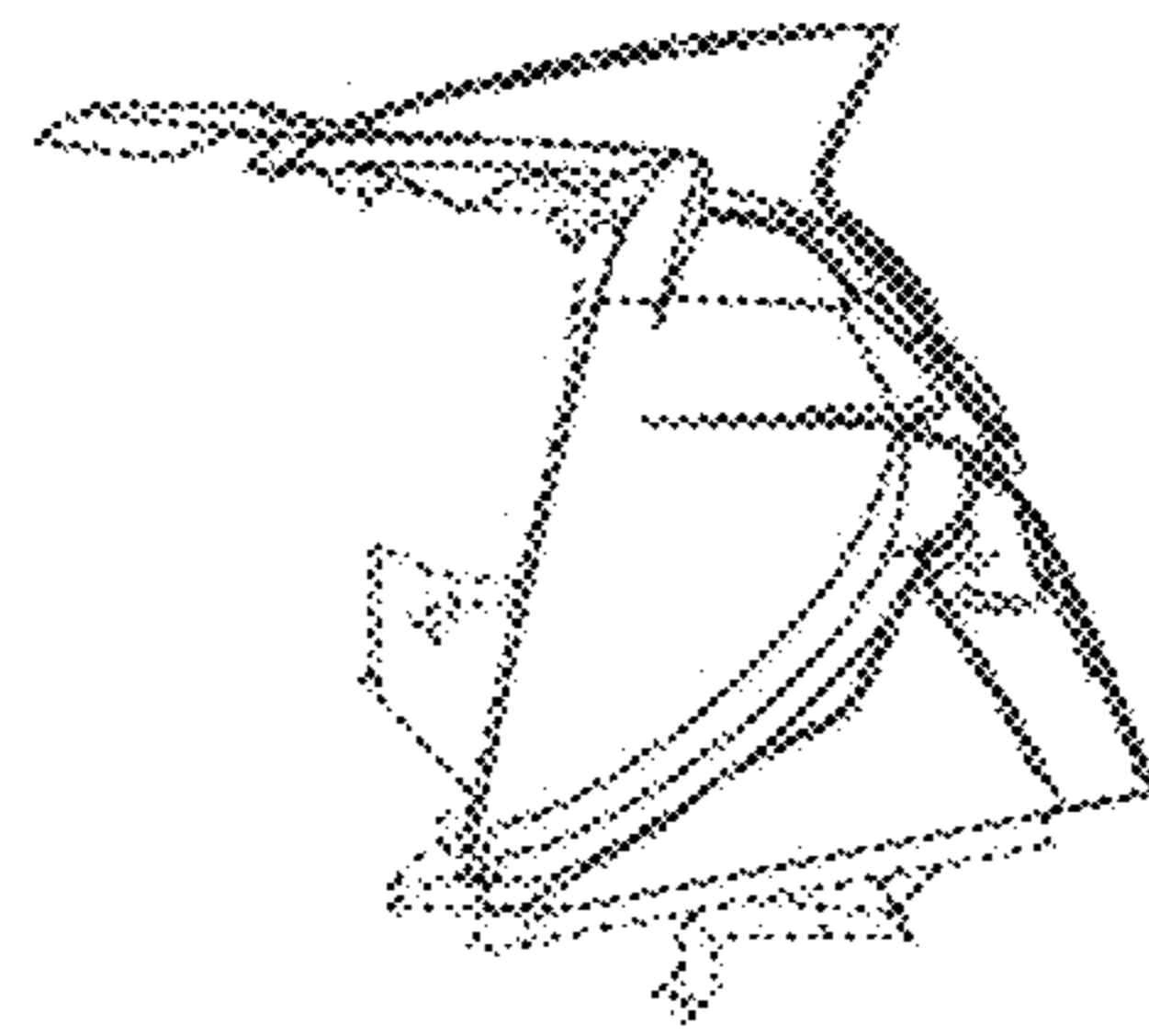

FIG.5

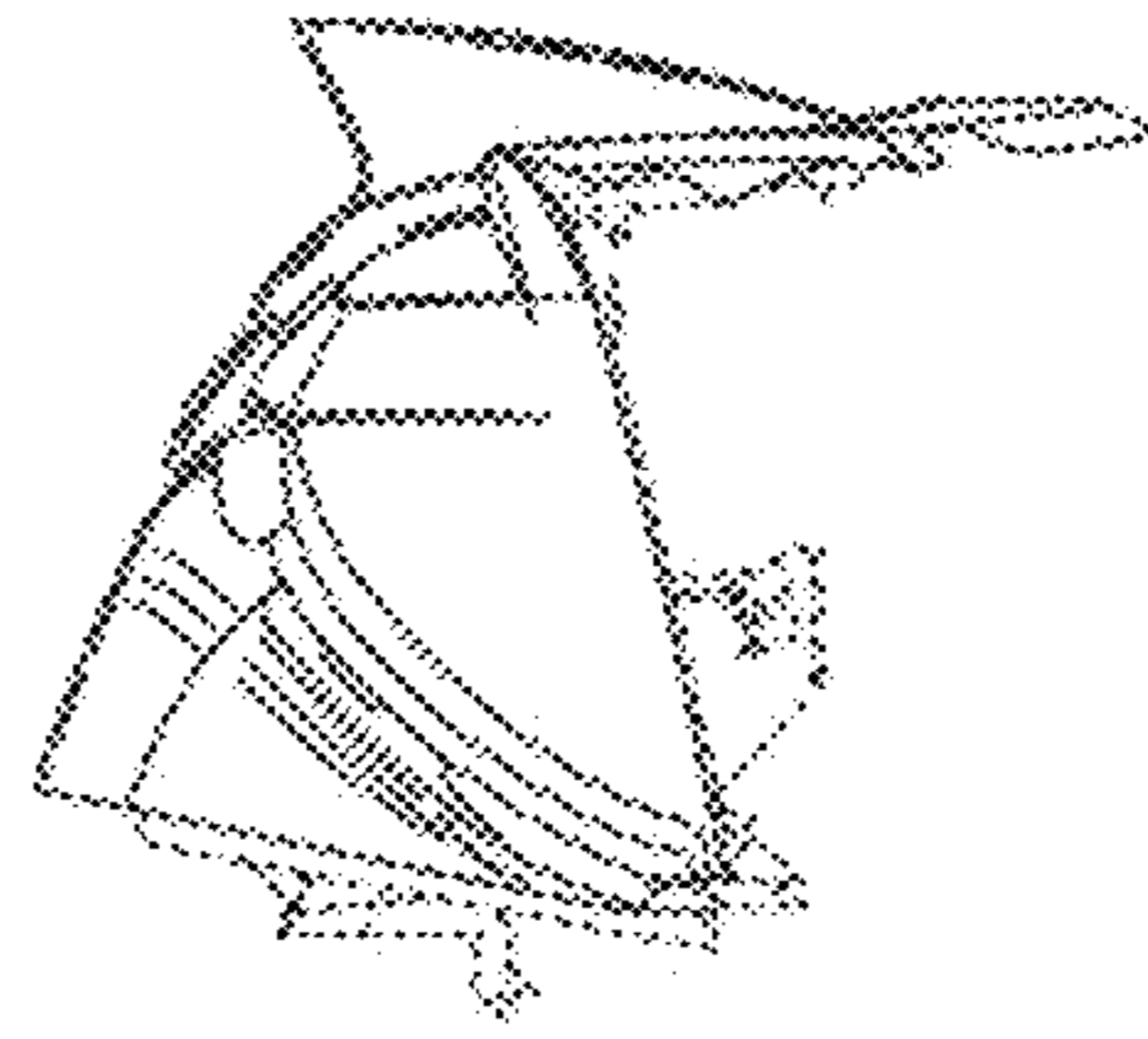

FIG.6