



US00D810380S

(12) **United States Design Patent**  
**Sommerfield et al.**

(10) **Patent No.:** **US D810,380 S**  
(45) **Date of Patent:** **\*\* Feb. 13, 2018**

(54) **GROCERY CART**  
(71) Applicant: **Dessie Mae Limited**, Whitehall, PA (US)  
(72) Inventors: **Matthew Sommerfield**, Allentown, PA (US); **Scott Doty**, Birmingham, AL (US); **Brendan Haentjens**, Bethlehem, PA (US); **Charlotte Ann Britto**, Whitehall, PA (US); **Laura Elizabeth Bynoe**, Whitehall, PA (US)

6,394,471 B1 \* 5/2002 Watson ..... B62B 1/12  
280/47.19  
7,168,715 B1 \* 1/2007 Friedman ..... B62B 3/006  
280/47.35  
D546,018 S \* 7/2007 Goodell ..... D34/21  
8,567,809 B2 \* 10/2013 White ..... B62B 5/067  
280/651  
8,844,949 B2 \* 9/2014 White ..... B62B 5/067  
280/47.36  
9,573,611 B2 \* 2/2017 Coyle ..... B62B 3/027  
2014/0035262 A1 \* 2/2014 White ..... B62B 5/067  
280/651

(73) Assignee: **Dessie Mae Limited**, Whitehall, PA (US)

\* cited by examiner

(\*\*) Term: **15 Years**

*Primary Examiner* — Cynthia Ramirez

*Assistant Examiner* — Gino Colan

(21) Appl. No.: **29/590,262**

(74) *Attorney, Agent, or Firm* — Design IP

(22) Filed: **Jan. 9, 2017**

(51) **LOC (11) Cl.** ..... **12-02**

(52) **U.S. Cl.**  
USPC ..... **D34/21**

(58) **Field of Classification Search**  
USPC ..... D34/12, 14, 16, 17, 19, 20, 21, 23, 25,  
D34/26; 280/651, 47.34, 47.19, 47.35,  
280/47.17, 654, 33.997, 639, 47.26, 47.36  
CPC ..... B62B 3/14; B62B 3/027; B62B 11/00;  
B62B 3/02; B62B 2205/02; B62B 1/045;  
B62B 1/208

See application file for complete search history.

(56) **References Cited**

U.S. PATENT DOCUMENTS

5,595,395 A \* 1/1997 Wilson ..... B62B 1/14  
280/47.19  
6,131,926 A \* 10/2000 Harlan ..... B62B 1/14  
280/47.26

(57) **CLAIM**

The ornamental design for a grocery cart, as shown and described.

**DESCRIPTION**

FIG. 1 is a front perspective view of a grocery cart showing our new design;

FIG. 2 is a front elevation view thereof;

FIG. 3 is a rear elevation view thereof;

FIG. 4 is a left side elevation view thereof;

FIG. 5 is a right side elevation view thereof; and,

FIG. 6 is a top view thereof.

The broken lines shown in the drawings are for the purpose of illustrating environmental structure and form no part of the claimed design.

**1 Claim, 6 Drawing Sheets**

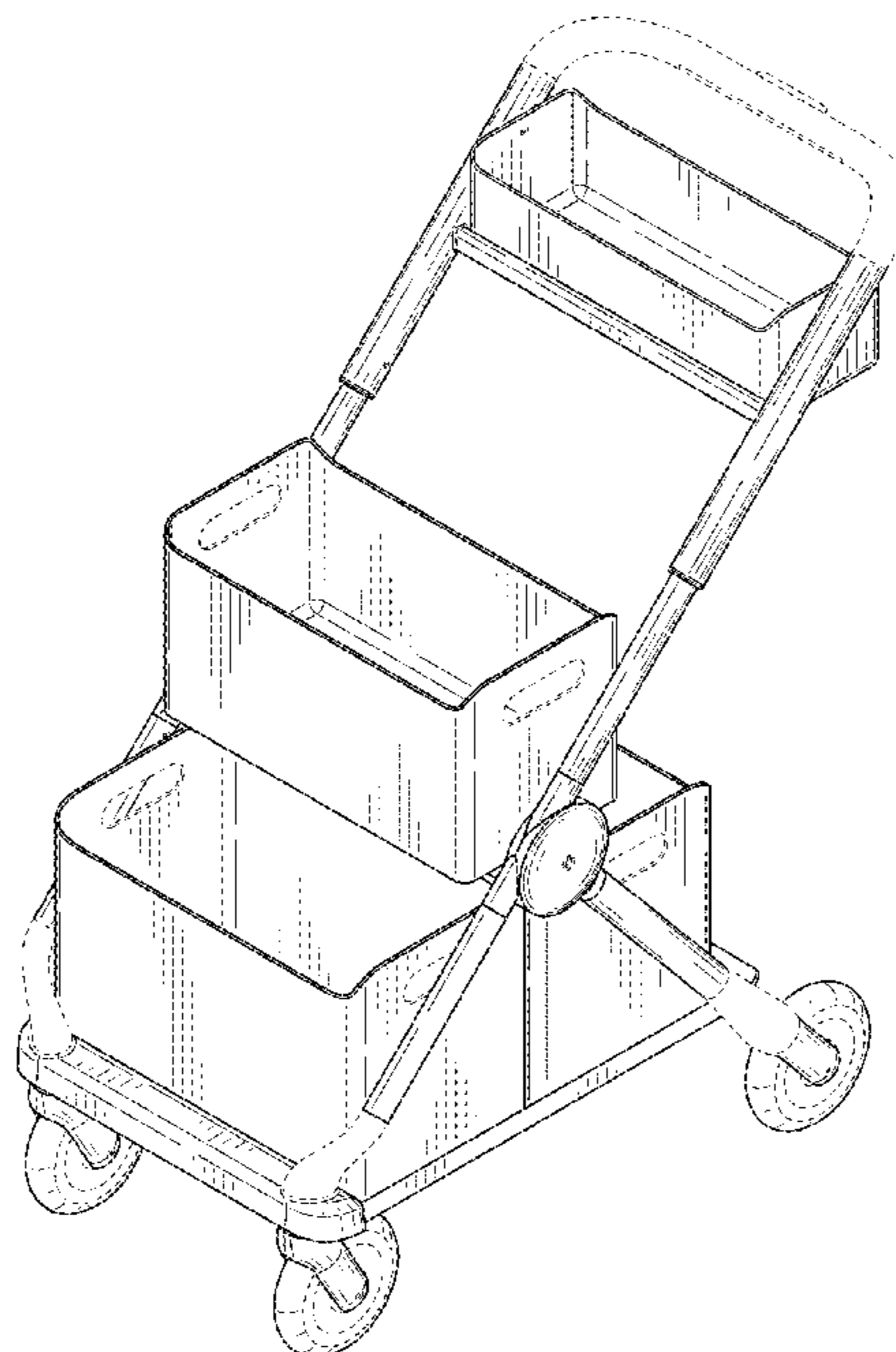

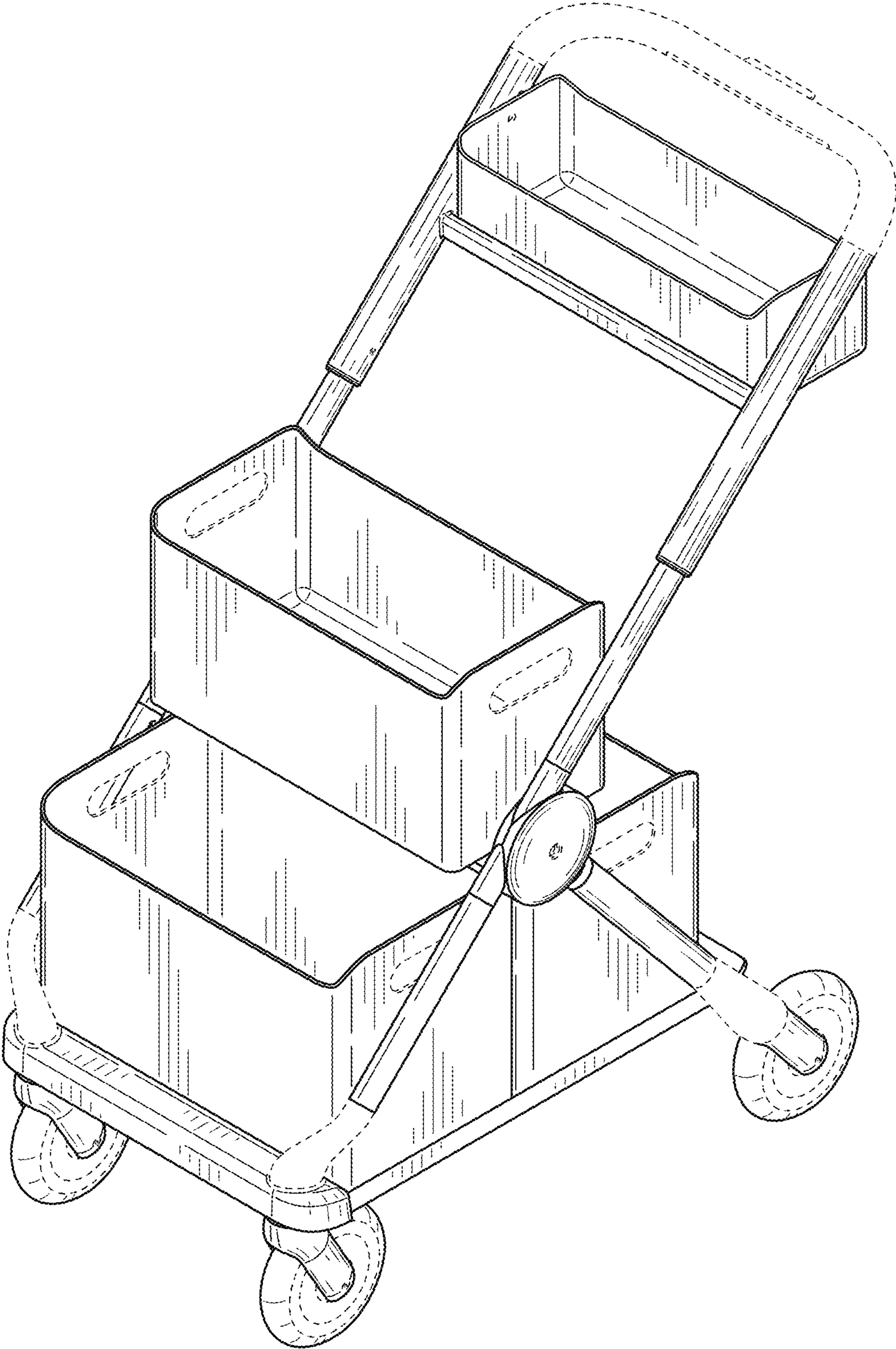

FIG. 1

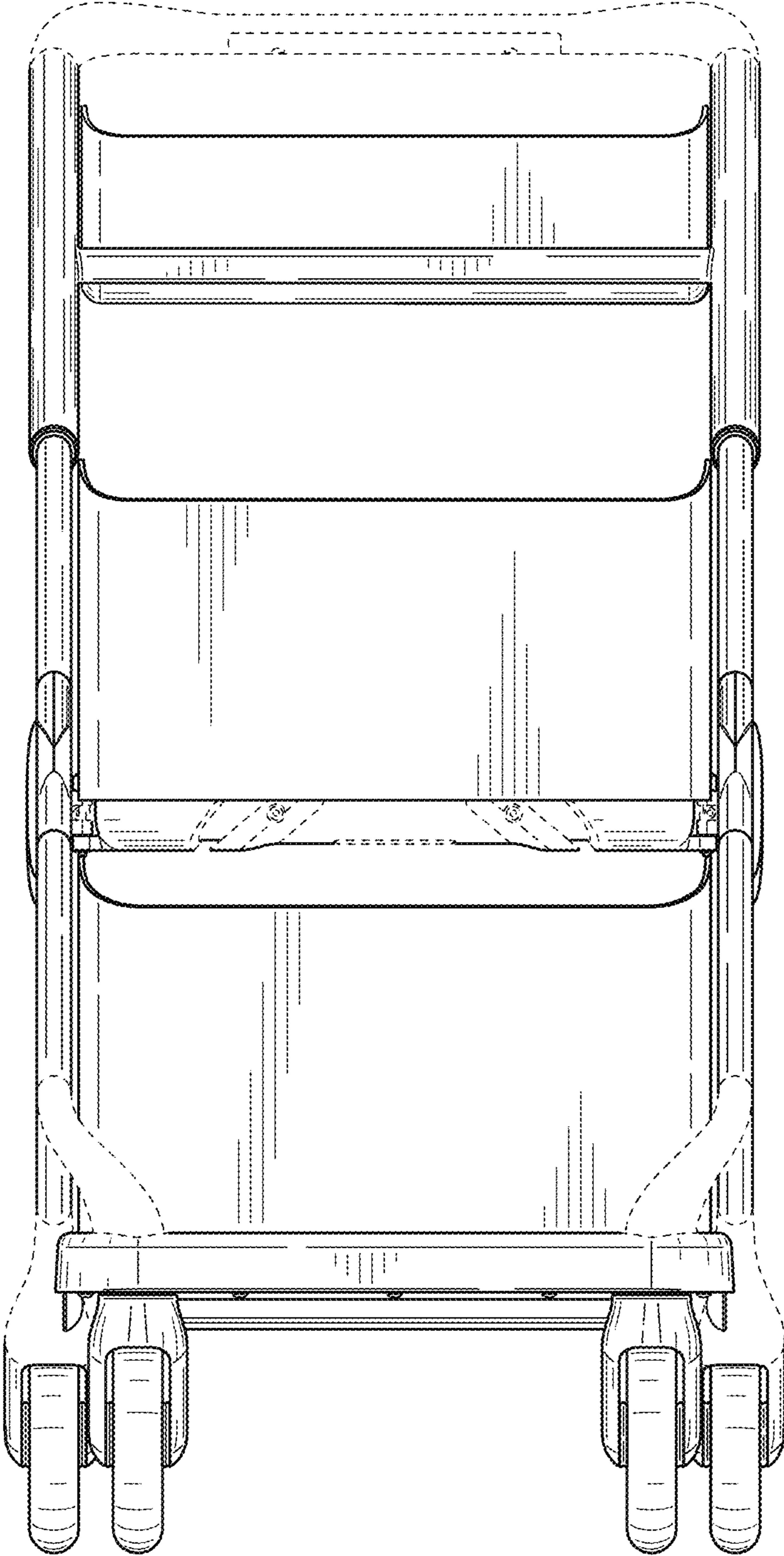

FIG. 2

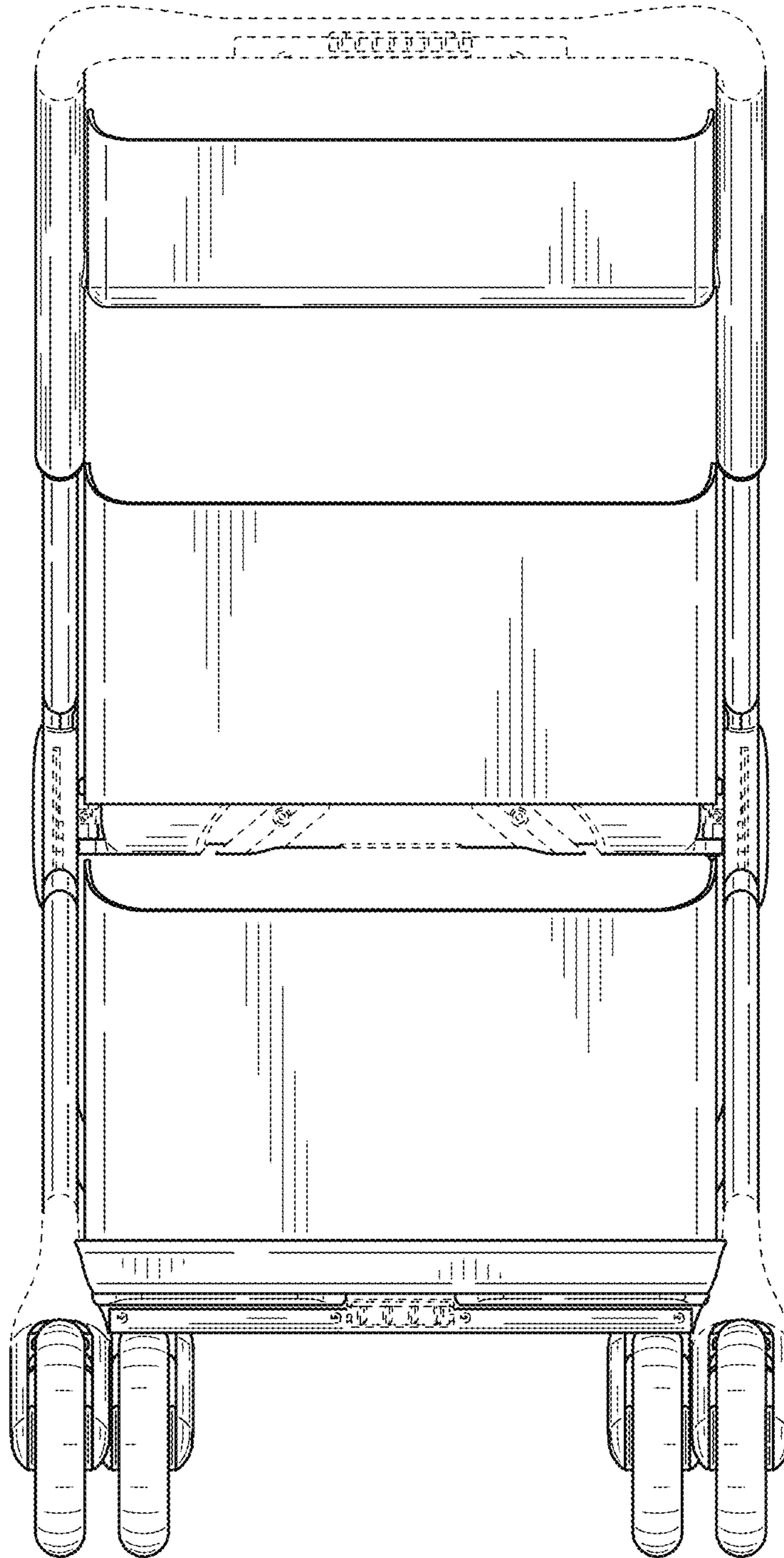

FIG. 3

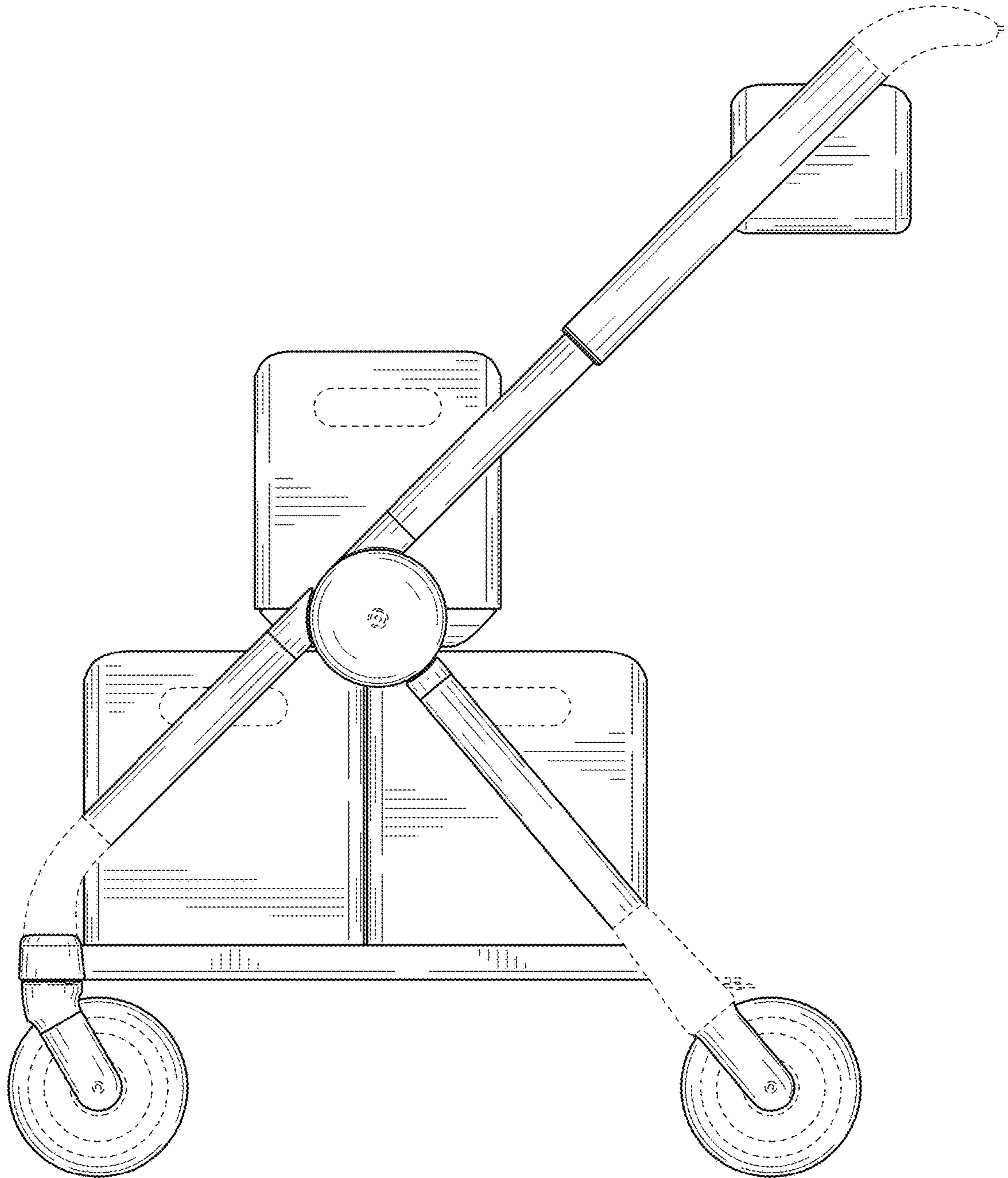

FIG. 4

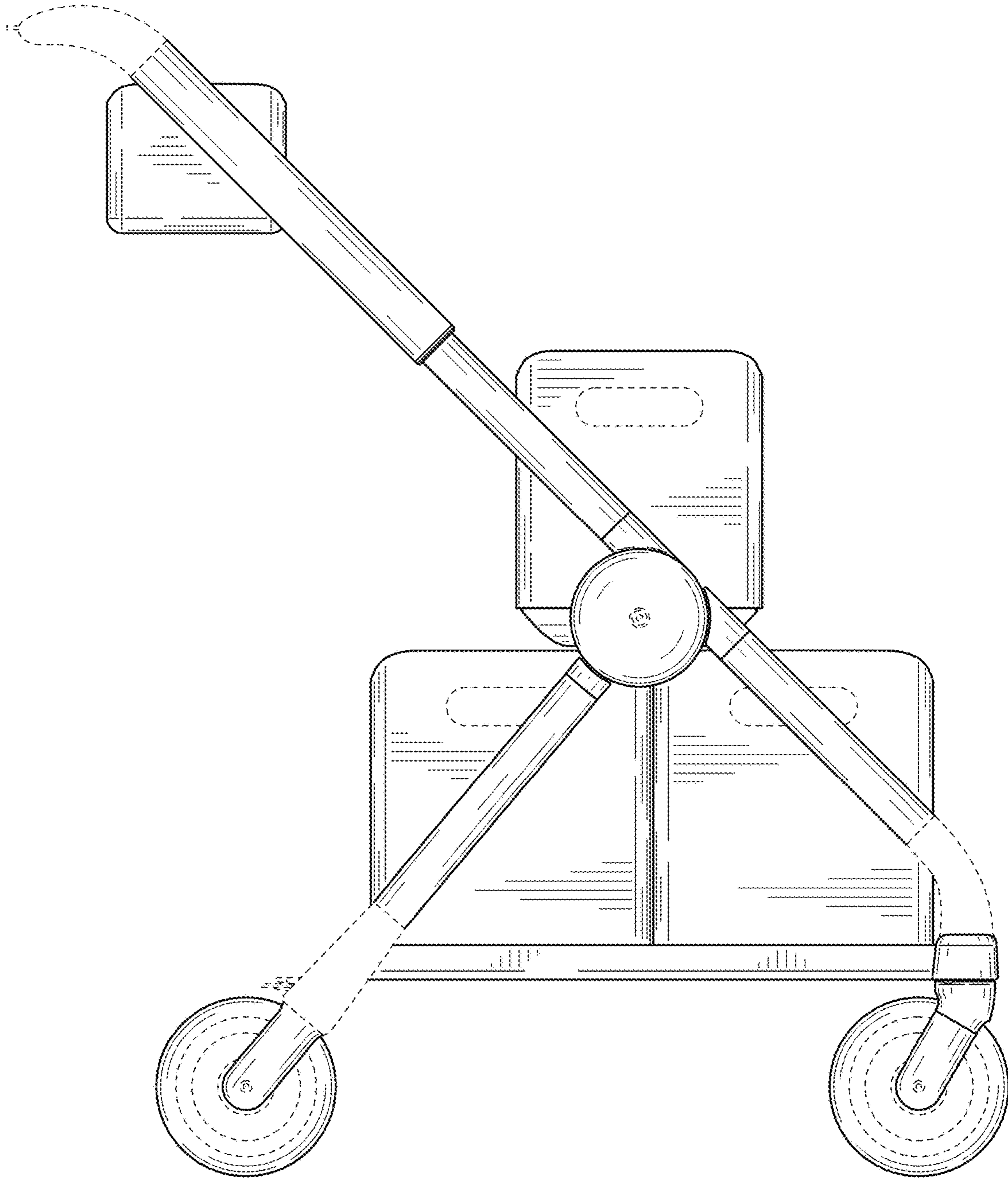

FIG. 5

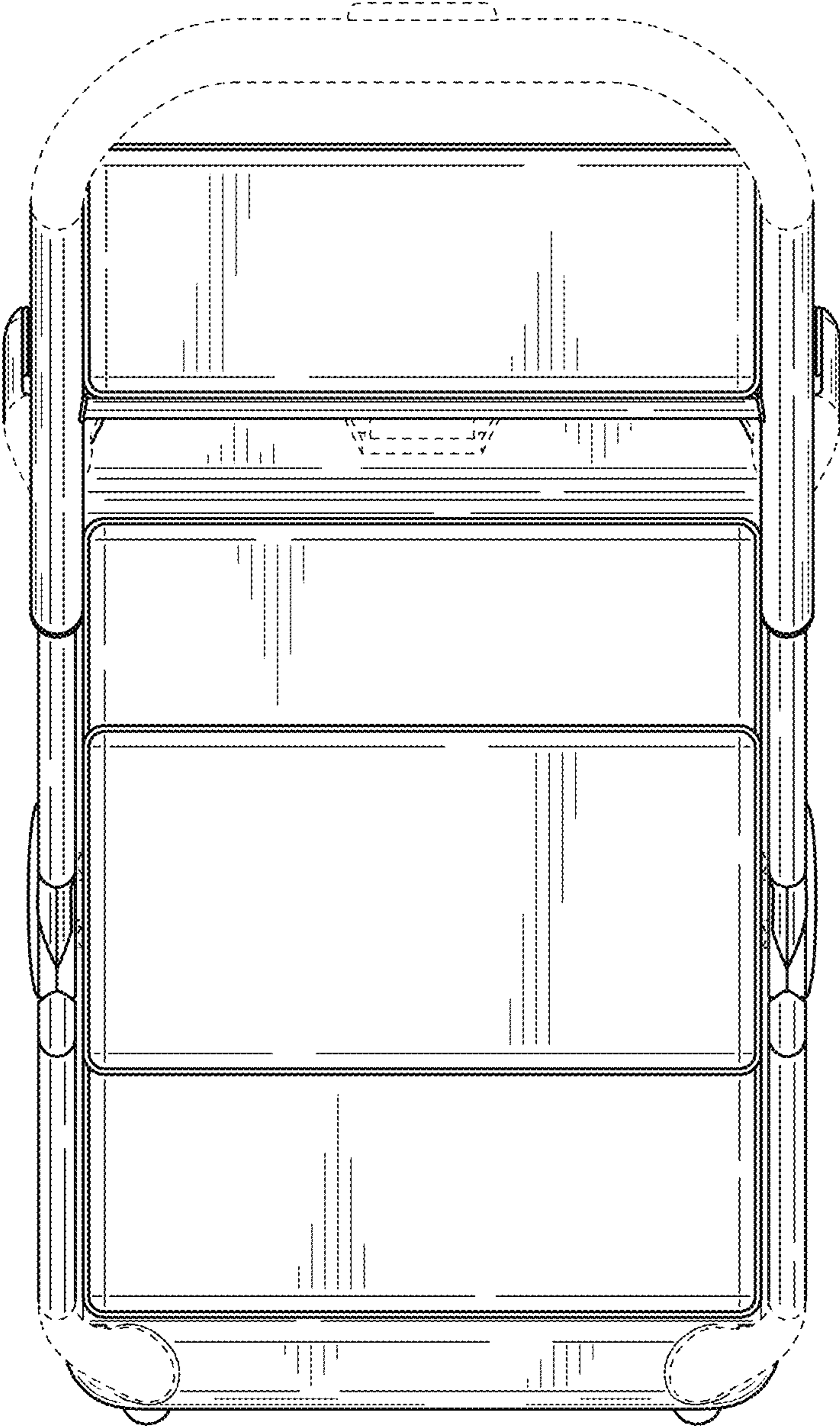

FIG. 6