



US00D810379S

(12) **United States Design Patent** (10) **Patent No.:** **US D810,379 S**
Sarian et al. (45) **Date of Patent:** **** Feb. 13, 2018**

- (54) **SWING CART**
- (71) Applicant: **United States Postal Service,**
Washington, DC (US)
- (72) Inventors: **Abe Sarian,** Anaheim, CA (US);
Edward Mascali, Washington, DC (US)
- (73) Assignee: **UNITED STATES POSTAL SERVICE,** Washington, DC (US)
- (**) Term: **15 Years**
- (21) Appl. No.: **29/546,268**
- (22) Filed: **Nov. 20, 2015**
- (51) **LOC (11) Cl.** **12-02**
- (52) **U.S. Cl.**
USPC **D34/17**
- (58) **Field of Classification Search**
USPC D34/12-15, 17, 18, 20-23, 26, 27, 10;
220/495.06, 9.3; D32/37; 211/175,
211/85.24, 194, 85.15; 280/651, 42,
280/47.17, 47.19, 43; 414/392; 248/98
CPC B62B 2202/66; B62B 3/02
See application file for complete search history.

- 5,967,342 A * 10/1999 Steffine D06F 81/00
211/85.15
- D418,654 S * 1/2000 Miller D34/10
- 6,691,879 B1 * 2/2004 Alvarez B62B 3/02
211/175
- D649,319 S * 11/2011 Renfrew D34/12
- D733,984 S * 7/2015 Tsai D32/37
- 2011/0017744 A1 * 1/2011 Sandhu D06F 95/004
220/495.06
- 2014/0217247 A1 * 8/2014 Kemmer B65B 67/1205
248/98

* cited by examiner

Primary Examiner — Cynthia Ramirez

Assistant Examiner — Gino Colan

(74) *Attorney, Agent, or Firm* — MH2 Technology Law Group, LLP

(57) **CLAIM**

The ornamental design for a swing cart, as shown and described.

DESCRIPTION

FIG. 1 is a front perspective view of a swing cart, showing our new design;
 FIG. 2 is a left side elevation view thereof;
 FIG. 3 is a right side elevation view thereof;
 FIG. 4 is a front elevation view thereof;
 FIG. 5 is rear elevation view thereof;
 FIG. 6 is a top plan view thereof;
 FIG. 7 is bottom plan view thereof; and,
 FIG. 8 is another front perspective view thereof.
 The broken lines in the drawings depict unclaimed environmental subject matter.

1 Claim, 7 Drawing Sheets

- (56) **References Cited**
U.S. PATENT DOCUMENTS
2,787,310 A * 4/1957 Zerbe D06F 95/004
220/9.3
5,772,236 A * 6/1998 Clark B62B 3/02
280/43

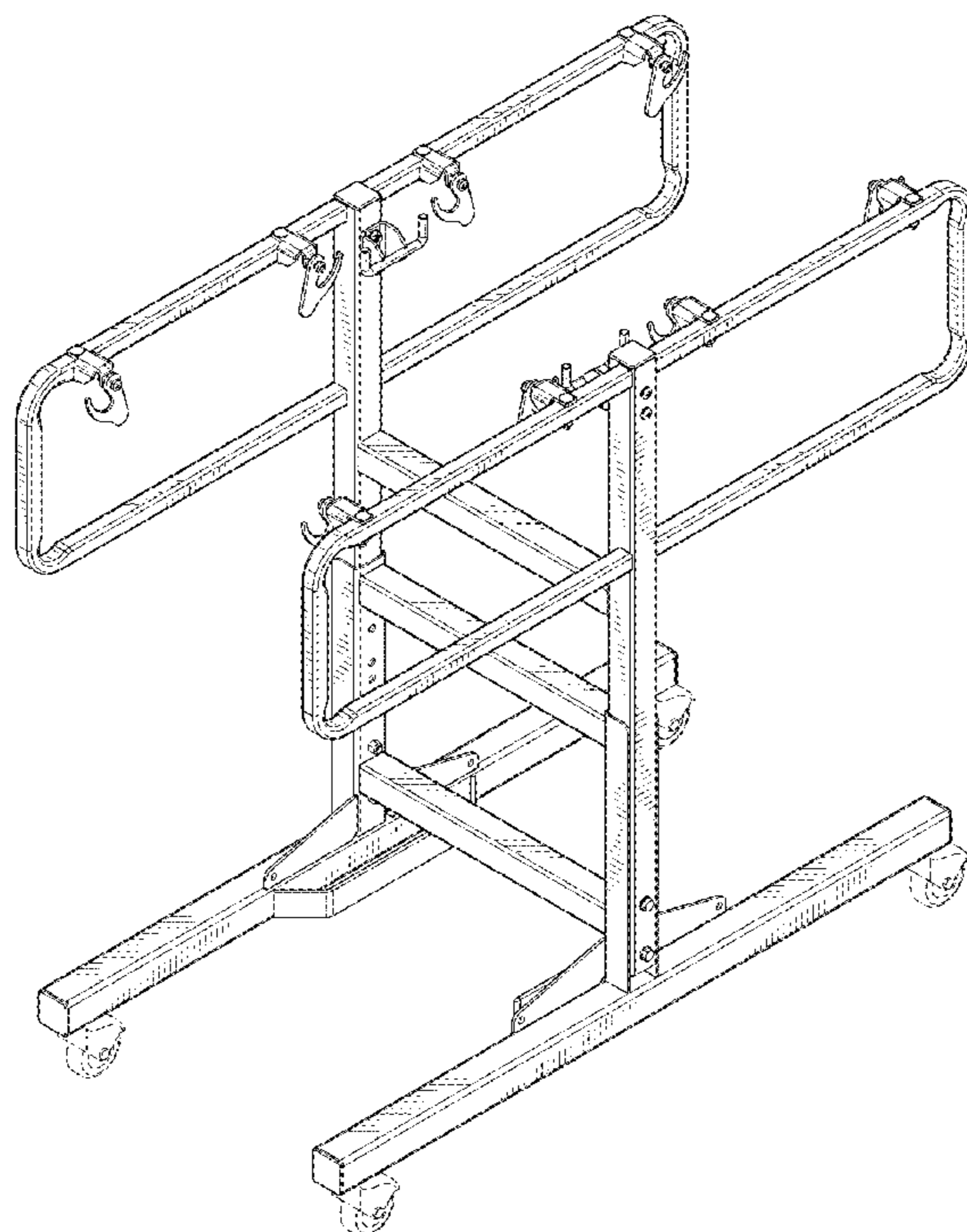

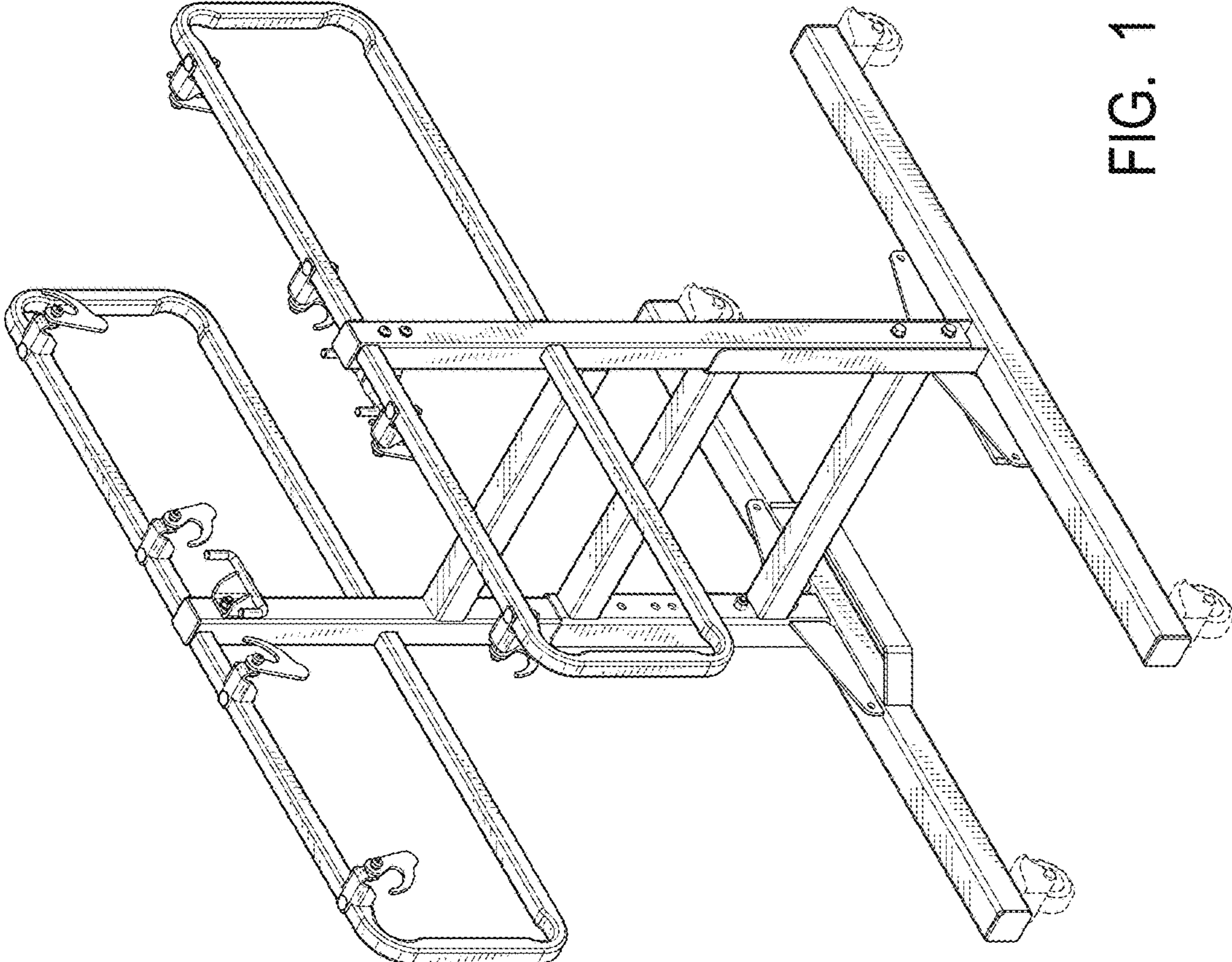

FIG. 1

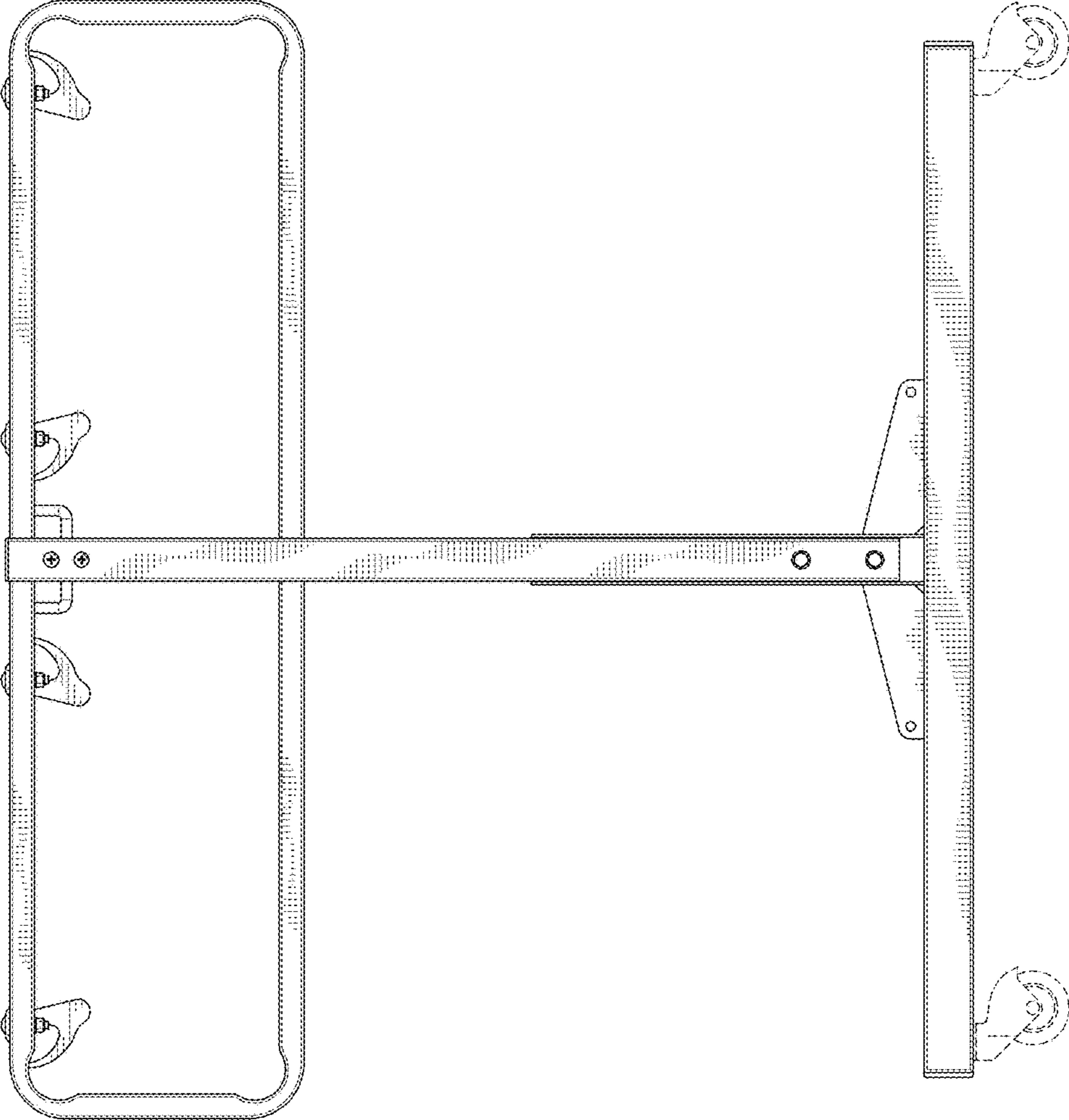

FIG. 2

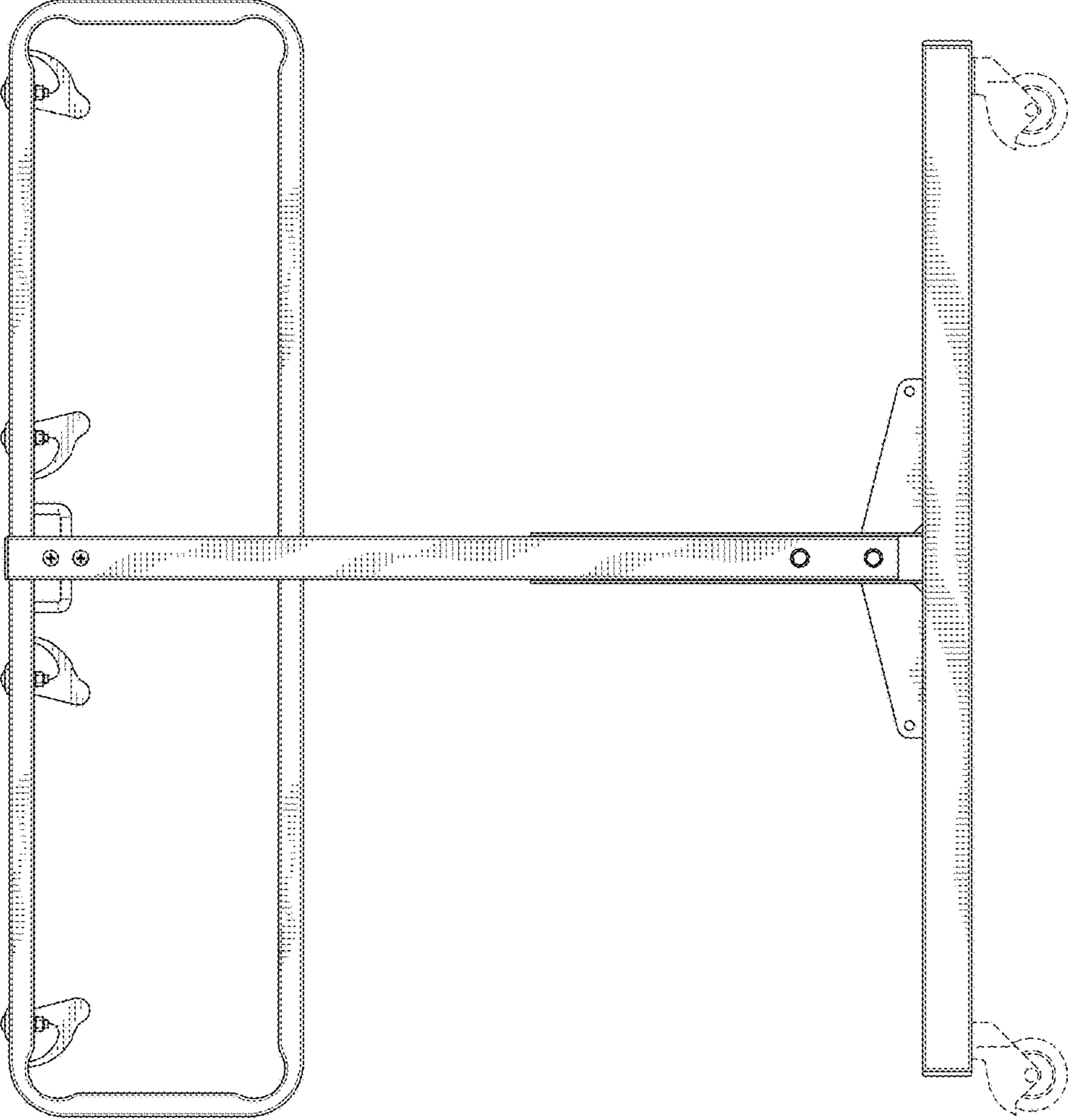

FIG. 3

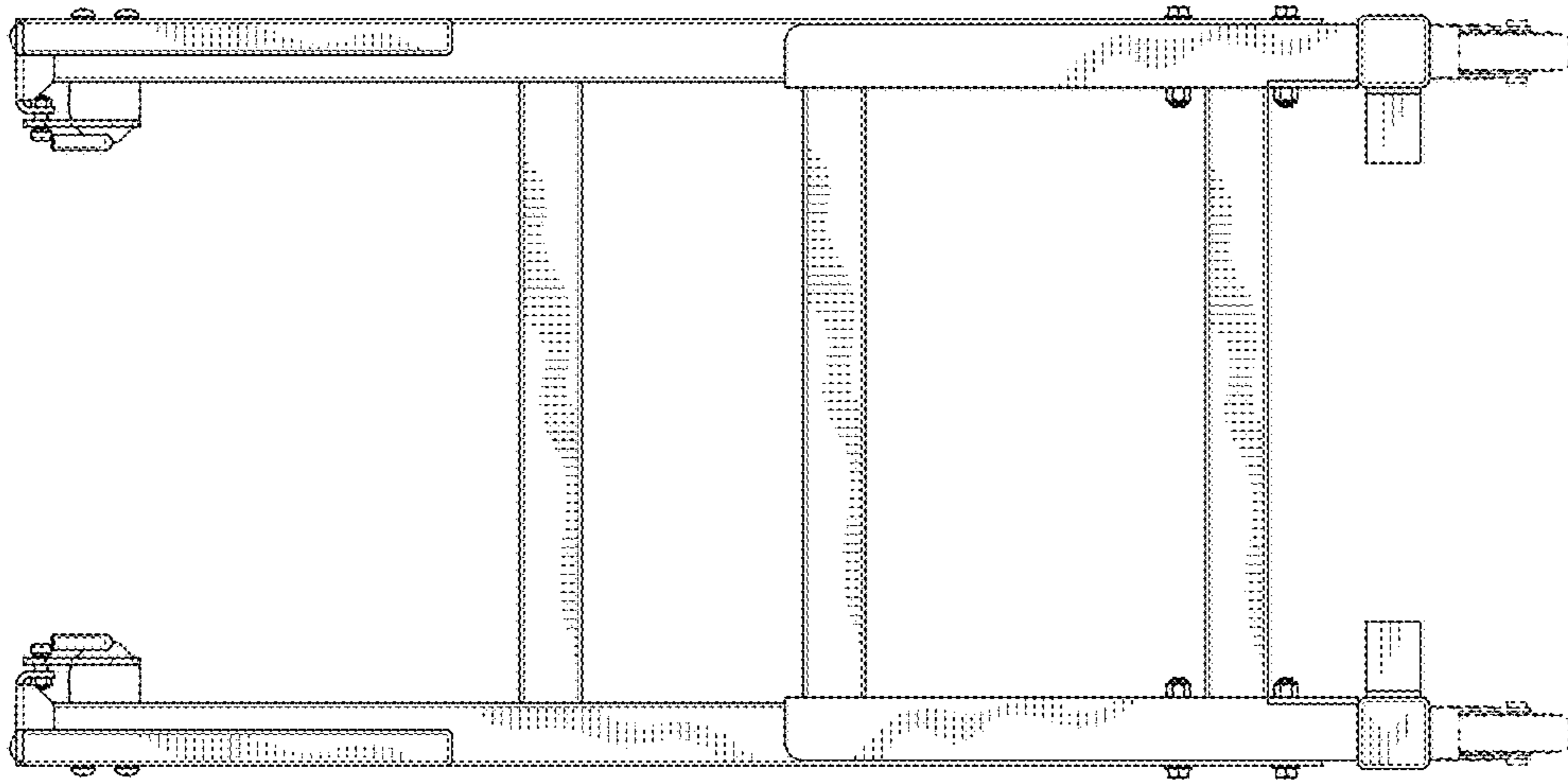

FIG. 5

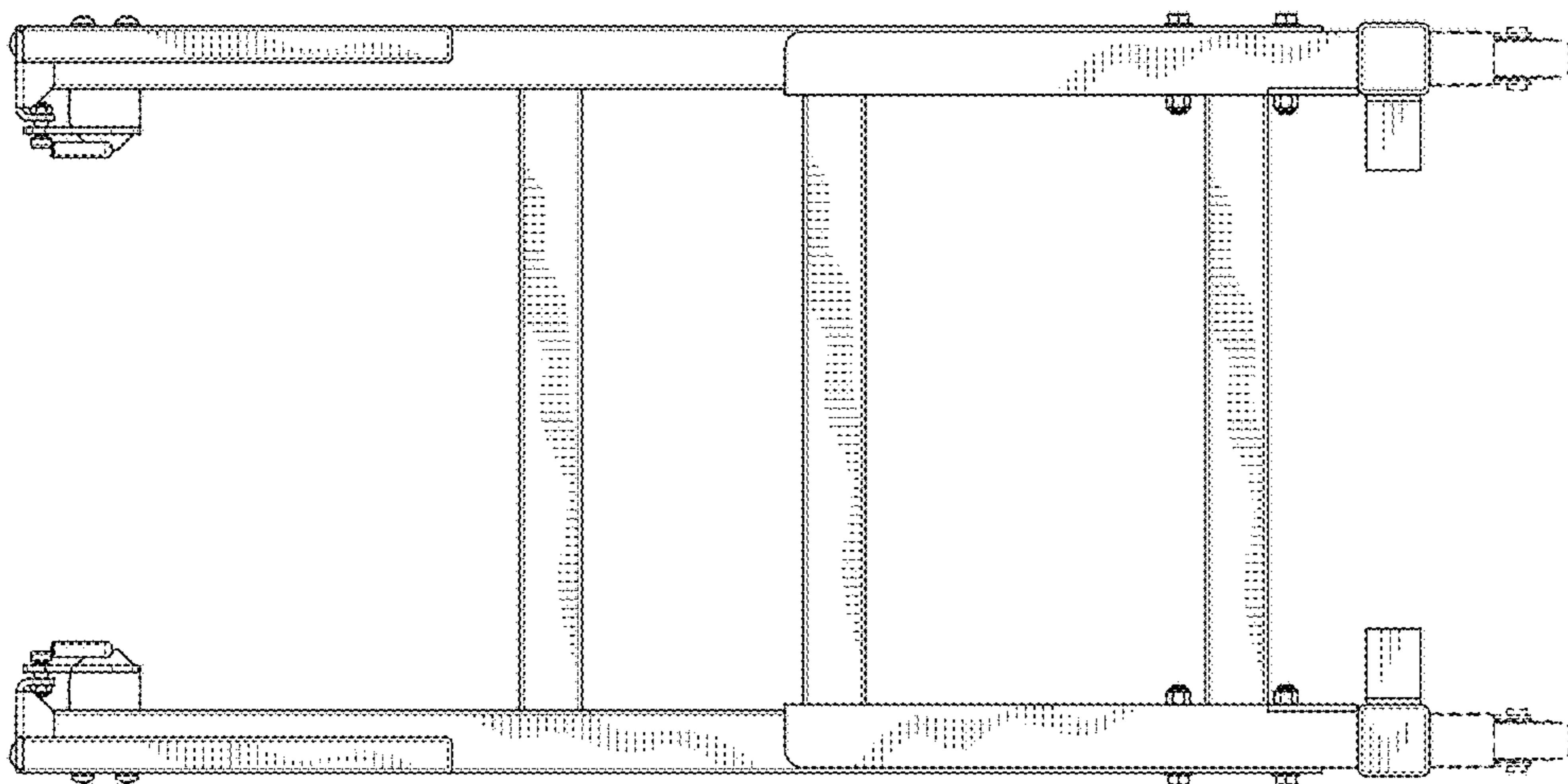

FIG. 4

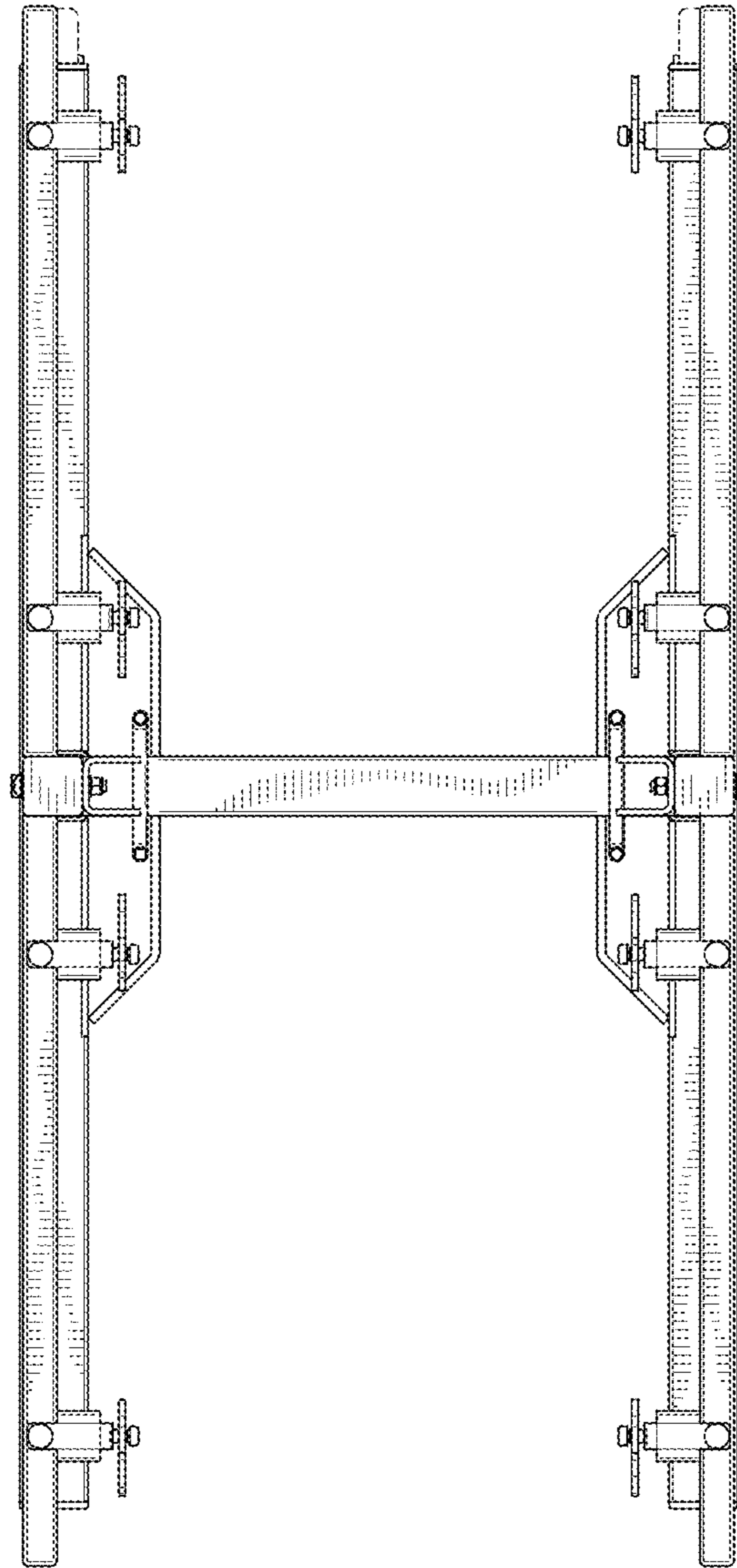

FIG. 6

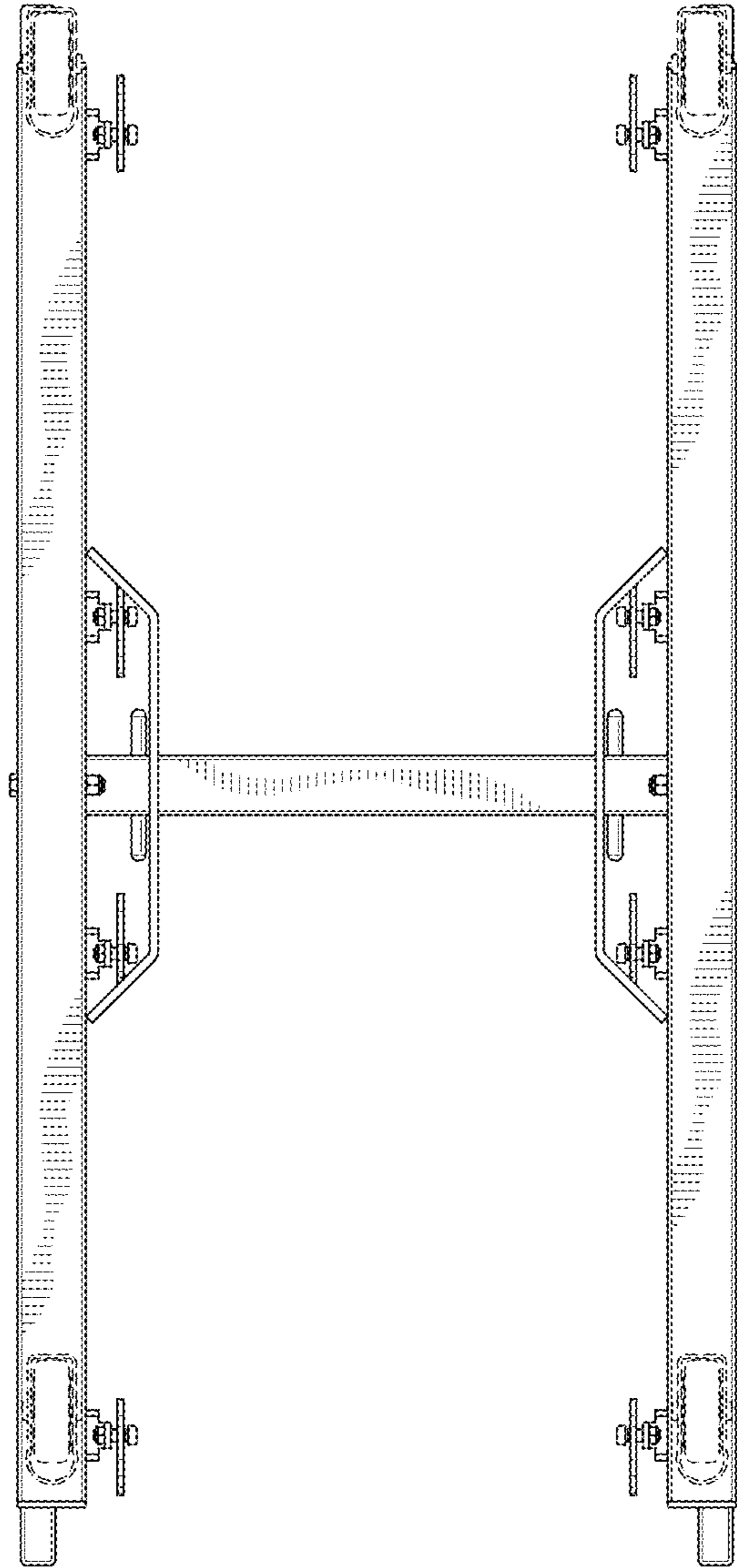

FIG. 7

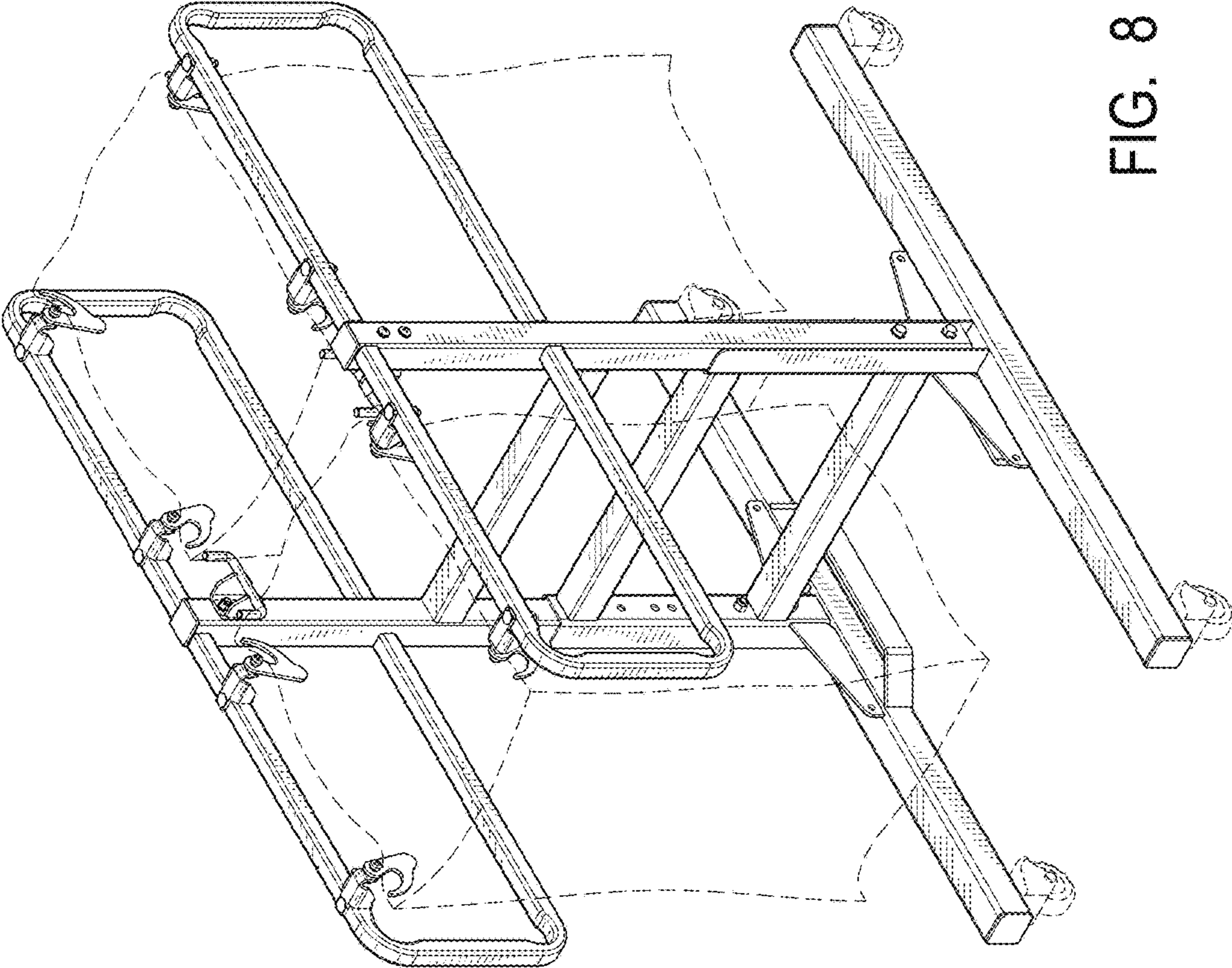

FIG. 8