



US00D809992S

(12) **United States Design Patent**
Hu et al.

(10) **Patent No.:** **US D809,992 S**
(45) **Date of Patent:** **** Feb. 13, 2018**

- (54) **MULTI-ROTOR AIRCRAFT**
- (71) Applicant: **EHANG, INC.**, Redwood City, CA (US)
- (72) Inventors: **Huazhi Hu**, Guangzhou (CN); **Hongsheng Jin**, Guangzhou (CN)
- (73) Assignee: **Guangzhou Ehang Intelligent Technology Co., LTD.**, Guangzhou (CN)

(**) Term: **15 Years**

(21) Appl. No.: **29/577,427**

(22) Filed: **Sep. 13, 2016**

(30) **Foreign Application Priority Data**

Jul. 5, 2016 (CN) 2016 3 0304069

(51) **LOC (11) Cl.** **12-07**

(52) **U.S. Cl.**
USPC **D12/328**

(58) **Field of Classification Search**
USPC D12/16.1, 319-345; D21/436, 441, 442, D21/443, 446, 447, 448, 449, 450, 451, D21/452, 453, 454
CPC ... B64C 27/20; B64C 27/08; B64C 2201/104; B64C 2201/021; B64C 2201/128; B64C 2201/024; B64C 2201/141; B64C 2201/108; B64C 39/024
See application file for complete search history.

(56) **References Cited**

U.S. PATENT DOCUMENTS

- D453,317 S * 2/2002 DeTore D12/328
- D710,454 S * 8/2014 Barajas D12/16.1
- D759,764 S * 6/2016 Lai D12/16.1

- D760,848 S * 7/2016 McKenna D12/16.1
- D763,134 S * 8/2016 Wang D12/16.1
- D772,991 S * 11/2016 Caubel D12/16.1
- D782,365 S * 3/2017 Hung D12/16.1
- 9,594,381 B1 * 3/2017 Clark G05D 1/101
- D785,541 S * 5/2017 Du D12/328
- 2016/0001879 A1 * 1/2016 Johannesson B64C 27/50
416/142
- 2016/0236777 A1 * 8/2016 Tang B64C 39/024
- 2016/0313742 A1 * 10/2016 Wang G05D 1/0669
- 2017/0076616 A1 * 3/2017 Kanade G08G 5/045

* cited by examiner

Primary Examiner — Robert M. Spear

Assistant Examiner — Marissa J Cash

(74) *Attorney, Agent, or Firm* — Dovas Law, P.C.

(57) **CLAIM**

The ornamental design for a multi-rotor aircraft, as shown and described.

DESCRIPTION

FIG. 1 is a perspective view of a multi-rotor aircraft showing our design.

FIG. 2 is a top plan view of the multi-rotor aircraft of FIG. 1.

FIG. 3 is a bottom plan view of the multi-rotor aircraft of FIG. 1.

FIG. 4 is a front elevational view of the multi-rotor aircraft of FIG. 1.

FIG. 5 is a rear elevational view of the multi-rotor aircraft of FIG. 1.

FIG. 6 is a right side elevational view of the multi-rotor aircraft of FIG. 1; and,

FIG. 7 is a left side elevational view of the multi-rotor aircraft of FIG. 1.

The broken lines of FIG. 3 illustrate a portion of the multi-rotor aircraft that forms no part of the claimed design.

1 Claim, 7 Drawing Sheets

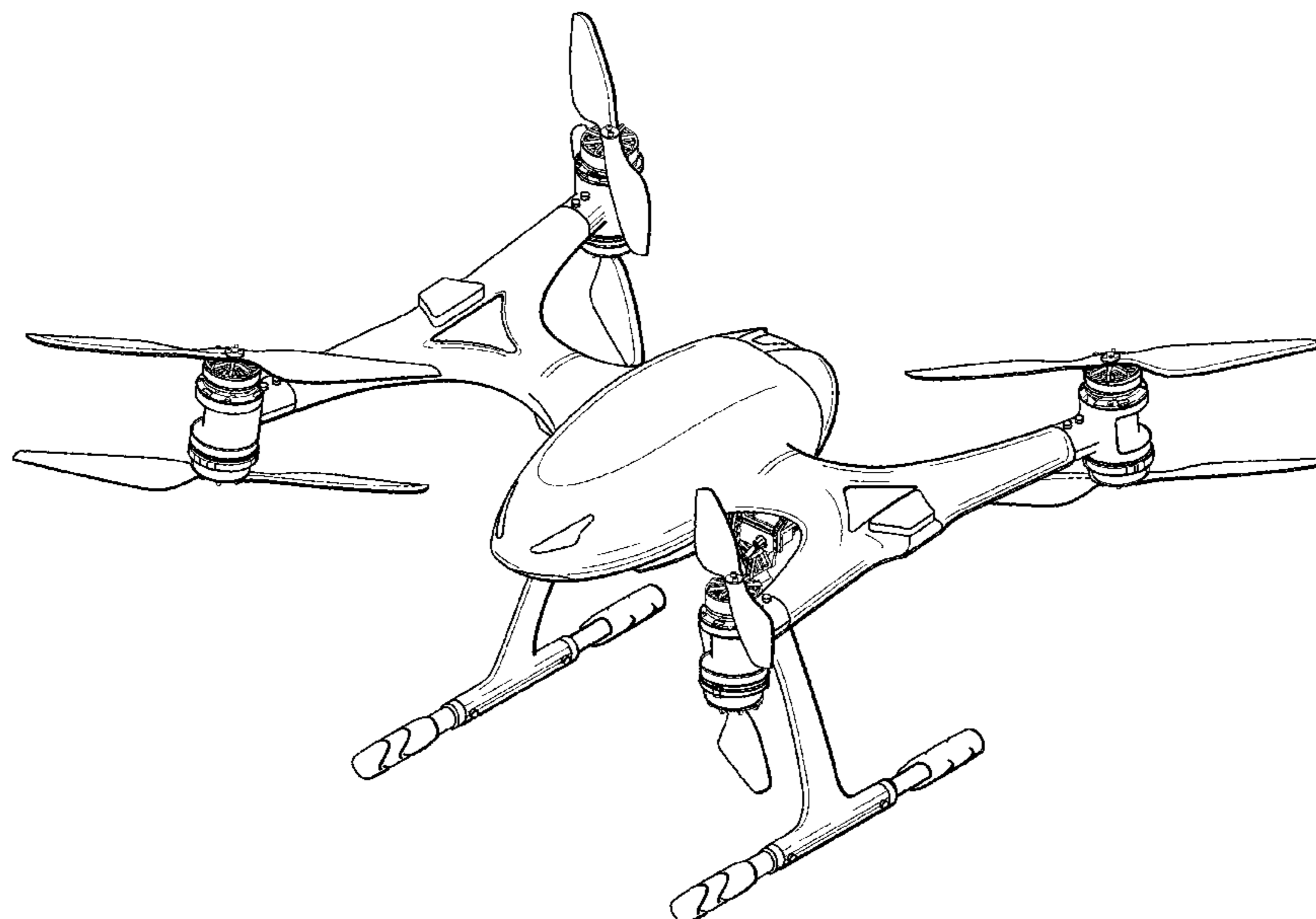

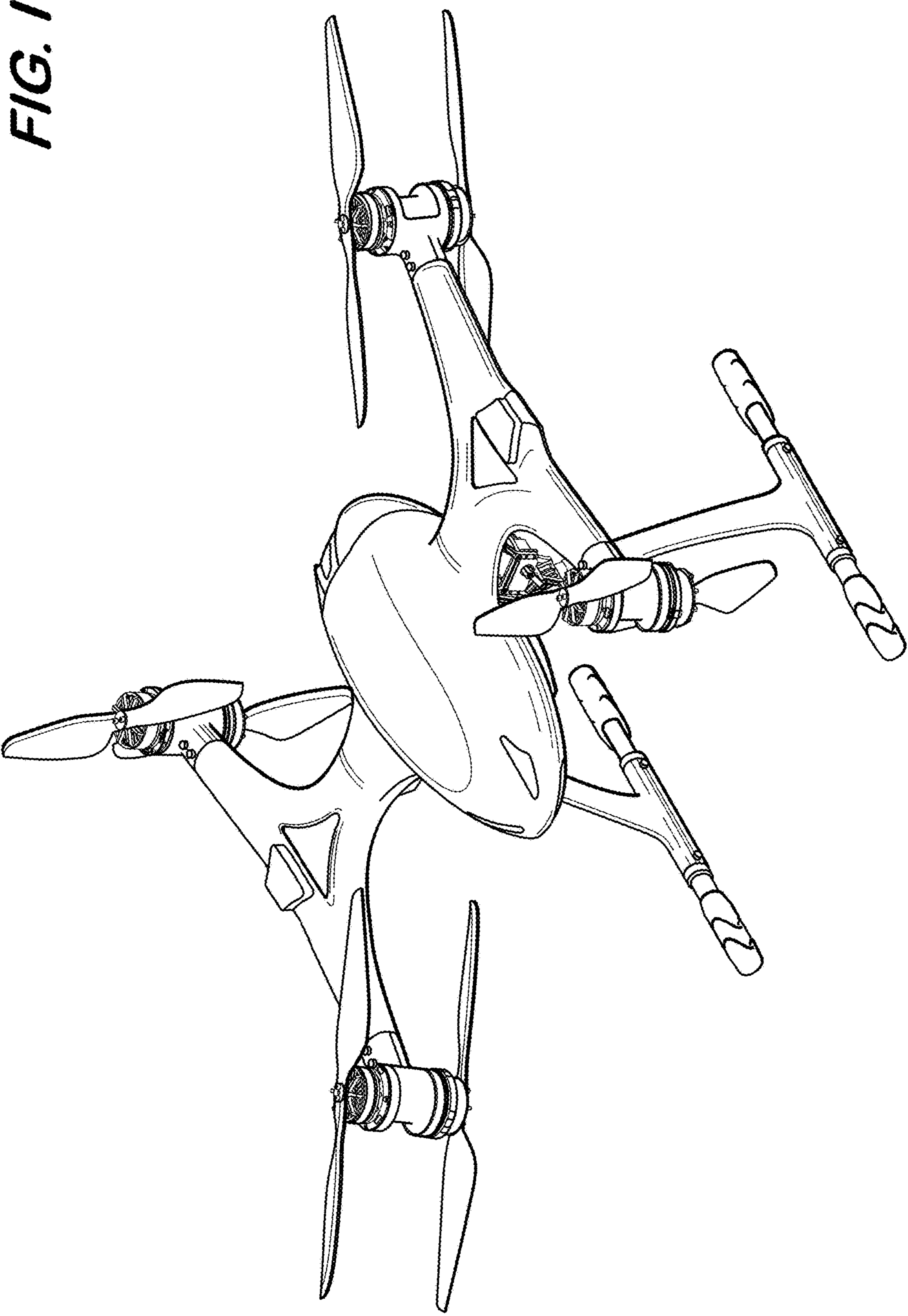

FIG. 1

FIG. 2

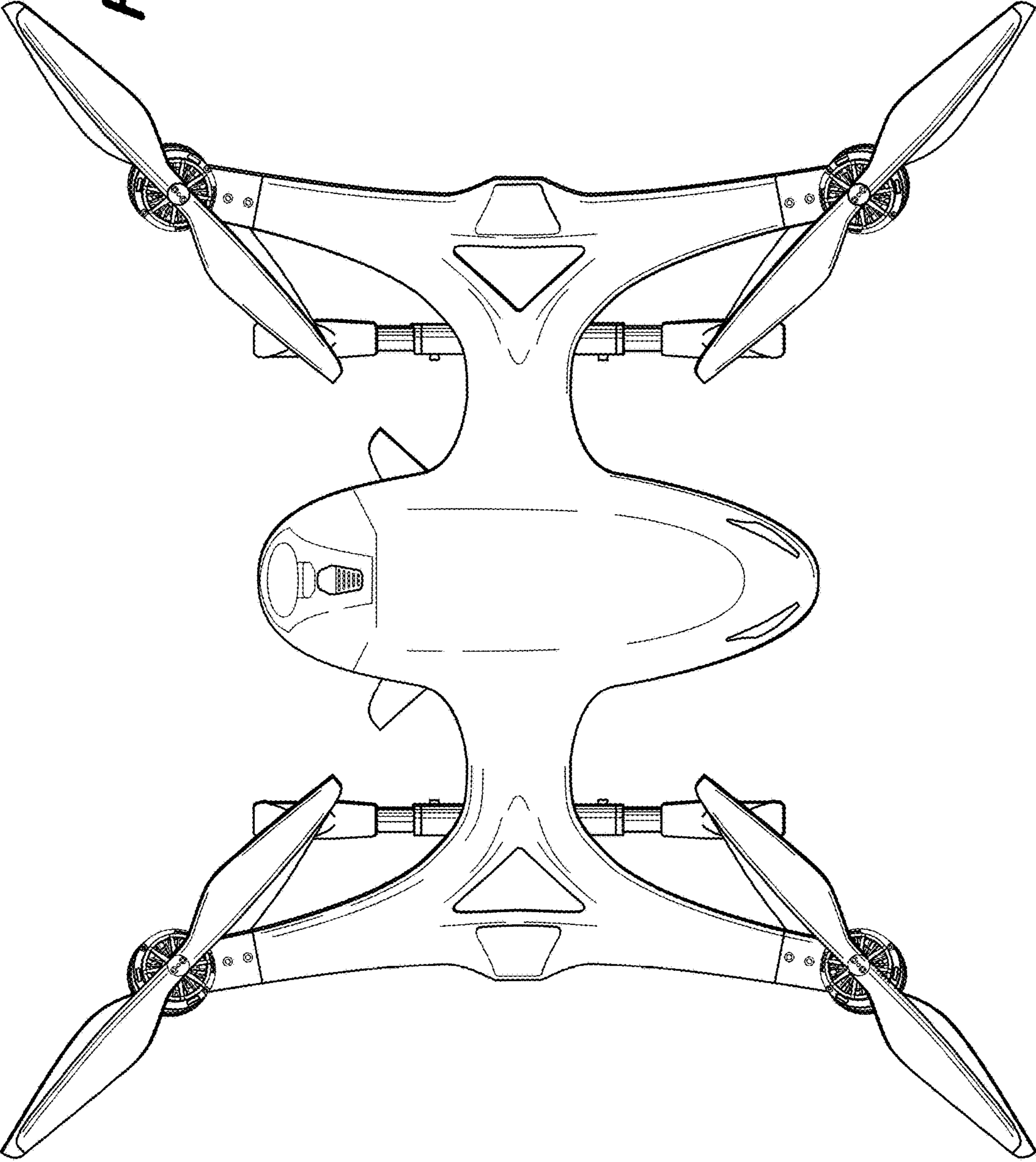

FIG. 3

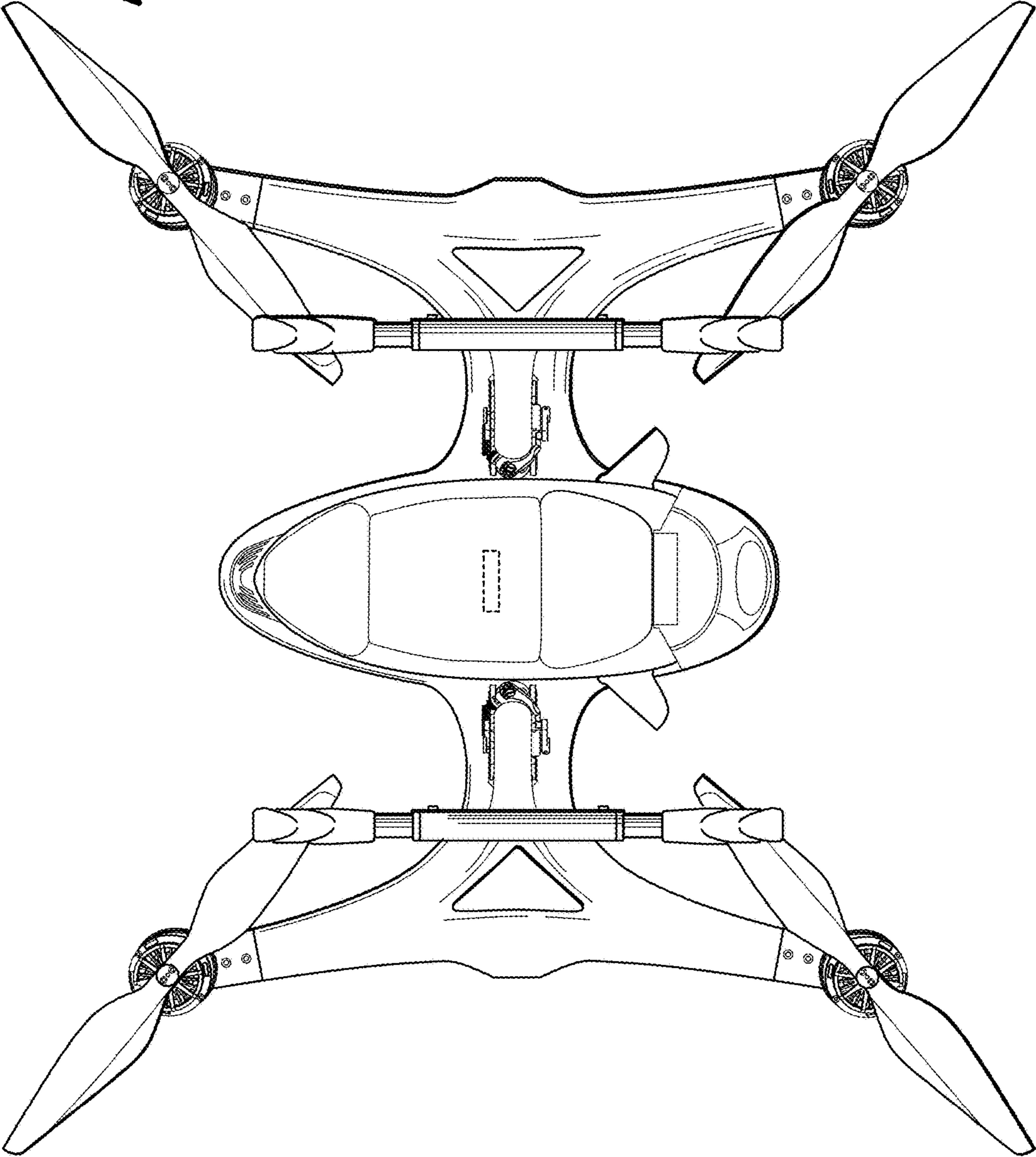

FIG. 4

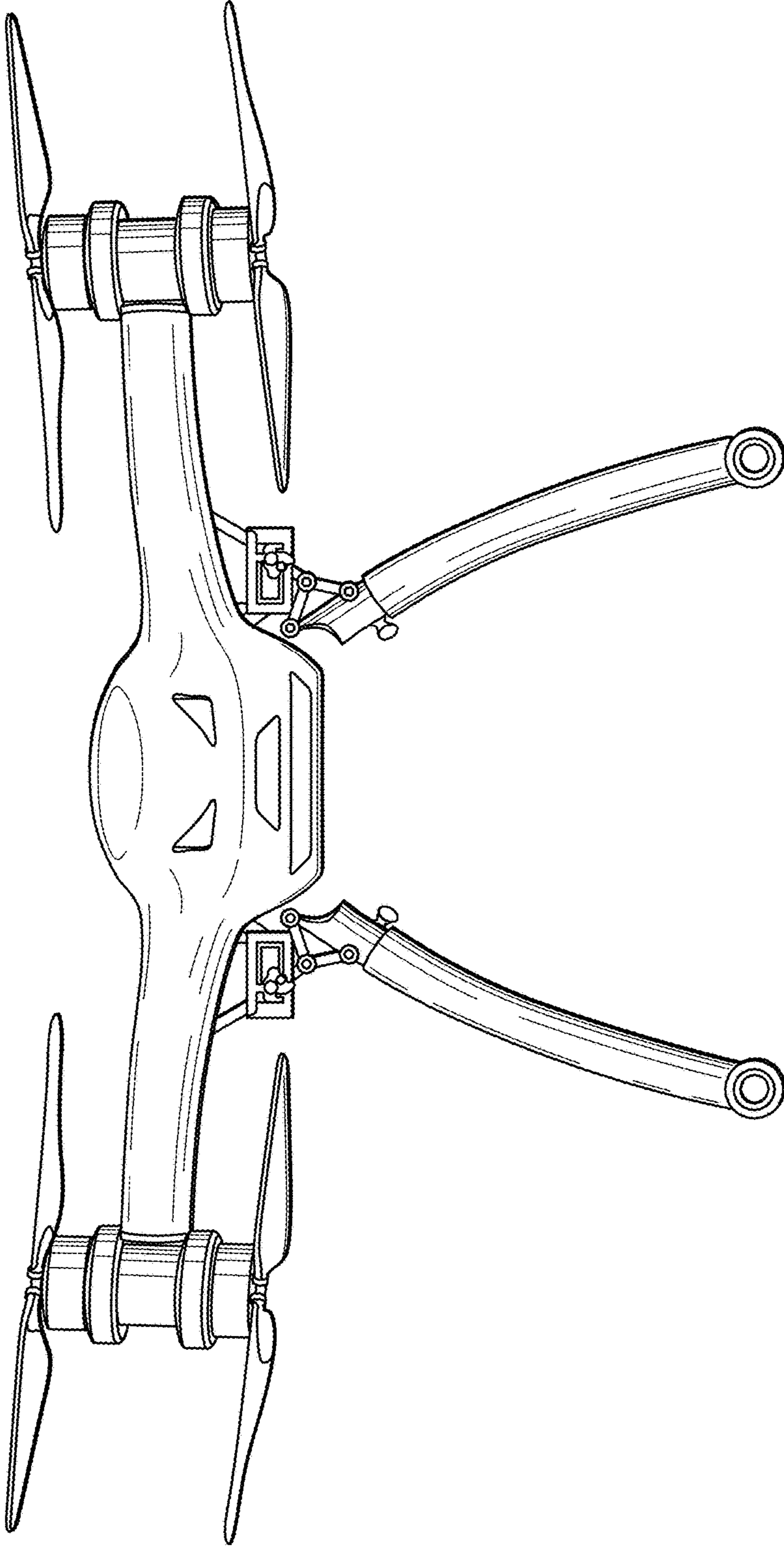

FIG. 5

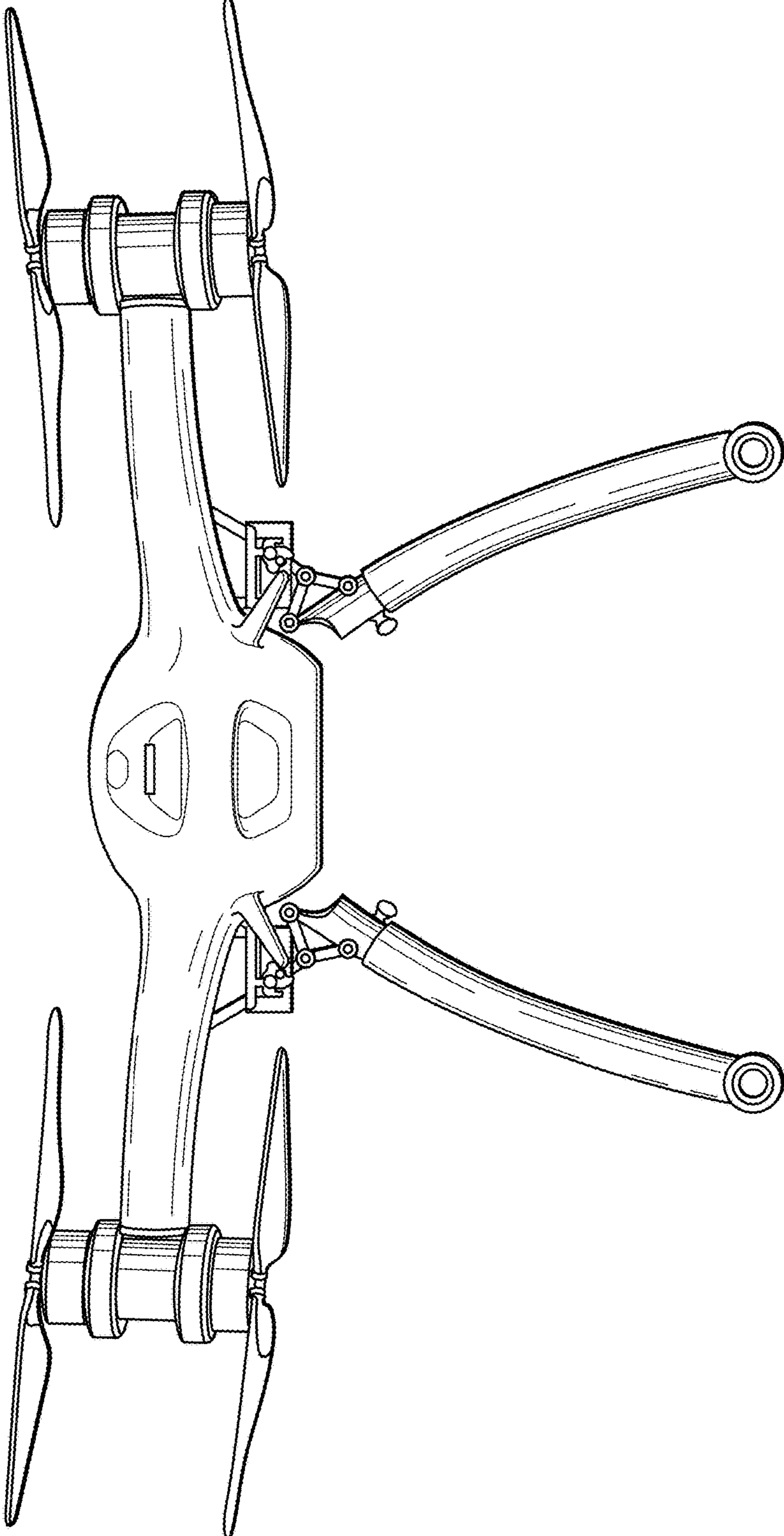

FIG. 6

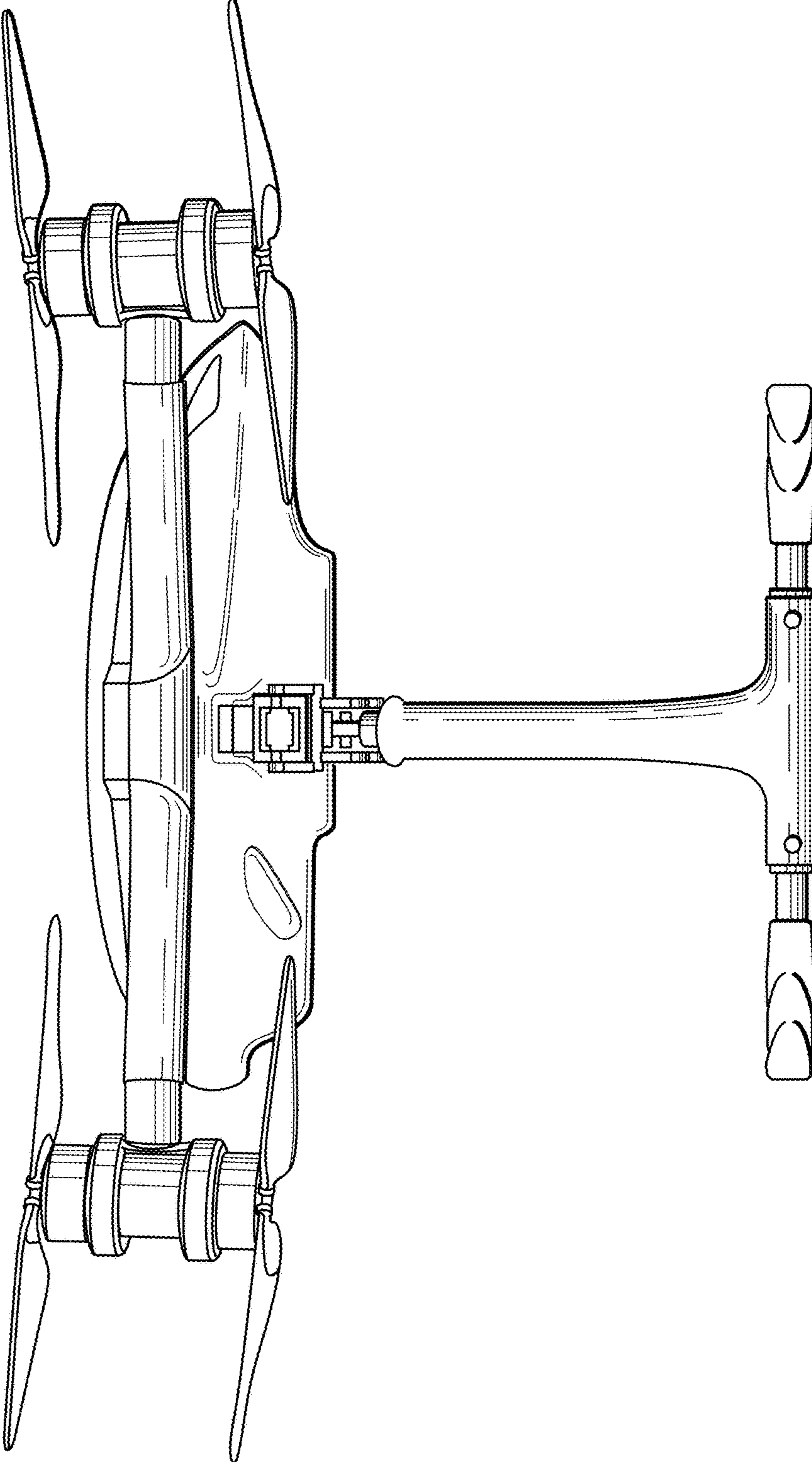

FIG. 7

