



US00D809810S

(12) **United States Design Patent**
Pizarro

(10) **Patent No.:** **US D809,810 S**
(45) **Date of Patent:** **** Feb. 13, 2018**

(54) **DUAL OSCILLATING CYCLE SADDLE AND SUPPORT SYSTEM**

(71) Applicant: **Marcelo A. Pizarro**, Lake Arrowhead, CA (US)

(72) Inventor: **Marcelo A. Pizarro**, Lake Arrowhead, CA (US)

(**) Term: **15 Years**

(21) Appl. No.: **29/580,903**

(22) Filed: **Oct. 13, 2016**

(51) **LOC (11) Cl.** **06-01**

(52) **U.S. Cl.**
USPC **D6/354**

(58) **Field of Classification Search**
USPC D6/340, 354; D12/110, 111
CPC ... B62J 1/002; B62J 1/005; B62J 1/007; B62J 1/26
See application file for complete search history.

(56) **References Cited**

U.S. PATENT DOCUMENTS

635,598	A *	10/1899	Rowe	B62J 1/005	297/201
642,191	A *	1/1900	Wright	B62J 1/005	297/201
4,387,925	A *	6/1983	Barker	B62J 1/002	297/195.13
D429,907	S *	8/2000	Minkow	D6/354	
D454,258	S *	3/2002	Yates	B62J 1/005	D6/354
6,652,025	B2 *	11/2003	Sylvester	B62J 1/005	297/201
6,761,400	B2 *	7/2004	Hobson	B62J 1/005	297/195.1
7,976,102	B2 *	7/2011	Chang	A47C 7/022	297/201

D792,715	S *	7/2017	Liu	D6/354	
D793,107	S *	8/2017	Liu	D6/354	
2003/0067195	A1 *	4/2003	Sylvester	B62J 1/005	297/201
2012/0086246	A1 *	4/2012	Belliveau	B62J 1/005	297/201

* cited by examiner

Primary Examiner — George D. Kirschbaum

Assistant Examiner — Natasha Vujcic

(74) *Attorney, Agent, or Firm* — Rutan & Tucker LLP;
Hani Z. Sayed; Ravi Mohan

(57) **CLAIM**

I claim, the ornamental design for a dual oscillating cycle saddle and support system, as shown and described.

DESCRIPTION

FIG. 1 is a front right perspective of a dual oscillating cycle saddle and support system in accordance with the present design.

FIG. 2 is a bottom left perspective of the dual oscillating cycle saddle and support system shown in FIG. 1.

FIG. 3 is a right side view of the dual oscillating cycle saddle and support system shown in FIG. 1.

FIG. 4 is a left side view of the dual oscillating cycle saddle and support system shown in FIG. 1.

FIG. 5 is a front view of the dual oscillating cycle saddle and support system shown in FIG. 1.

FIG. 6 is a rear view of the dual oscillating cycle saddle and support system shown in FIG. 1.

FIG. 7 is a top view of the dual oscillating cycle saddle and support system shown in FIG. 1; and,

FIG. 8 is a bottom view of the dual oscillating cycle saddle and support system shown in FIG. 1.

The broken lines in the drawings illustrates portions of the dual oscillating cycle saddle and support system which forms no part of the claimed design.

1 Claim, 8 Drawing Sheets

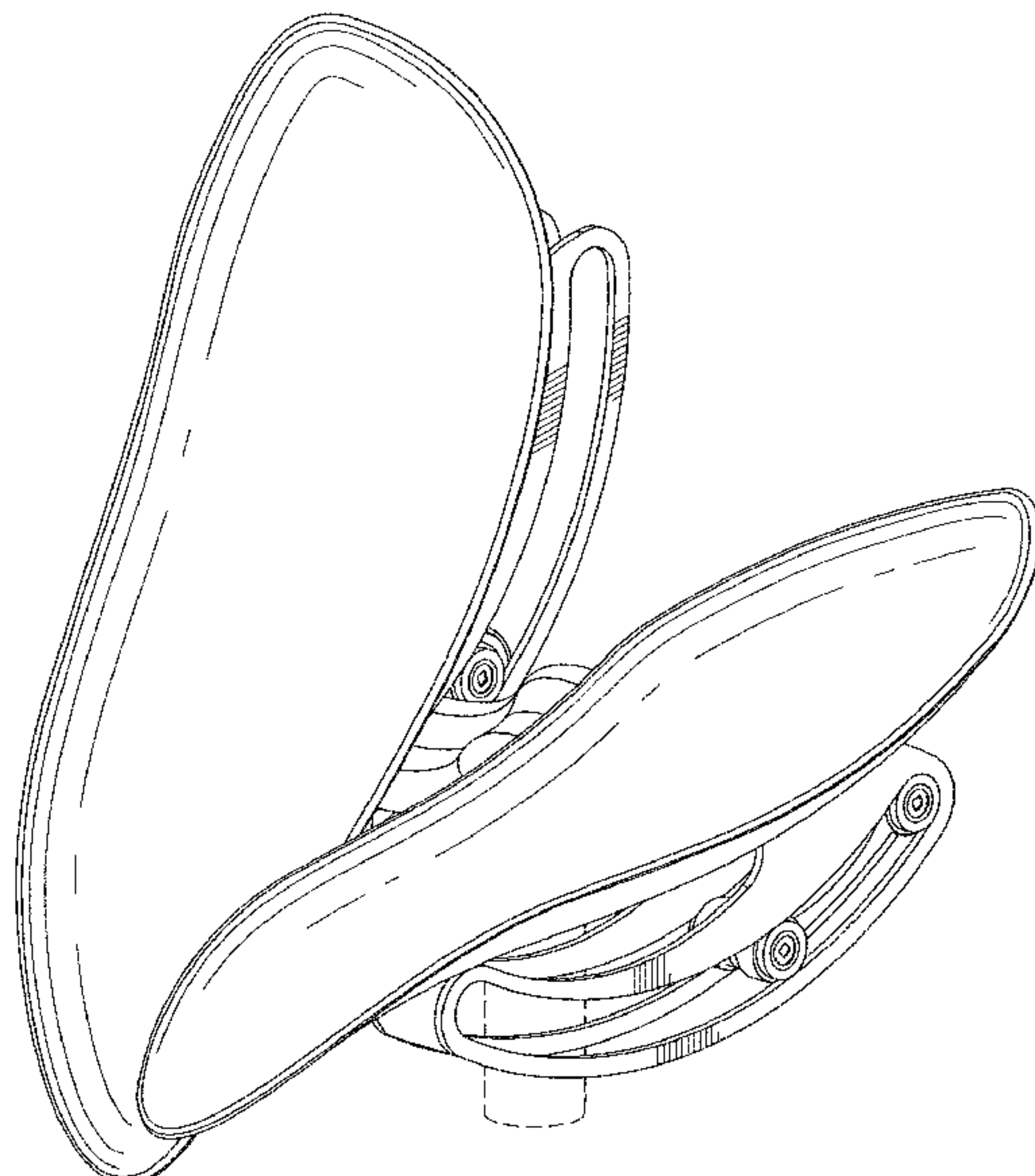

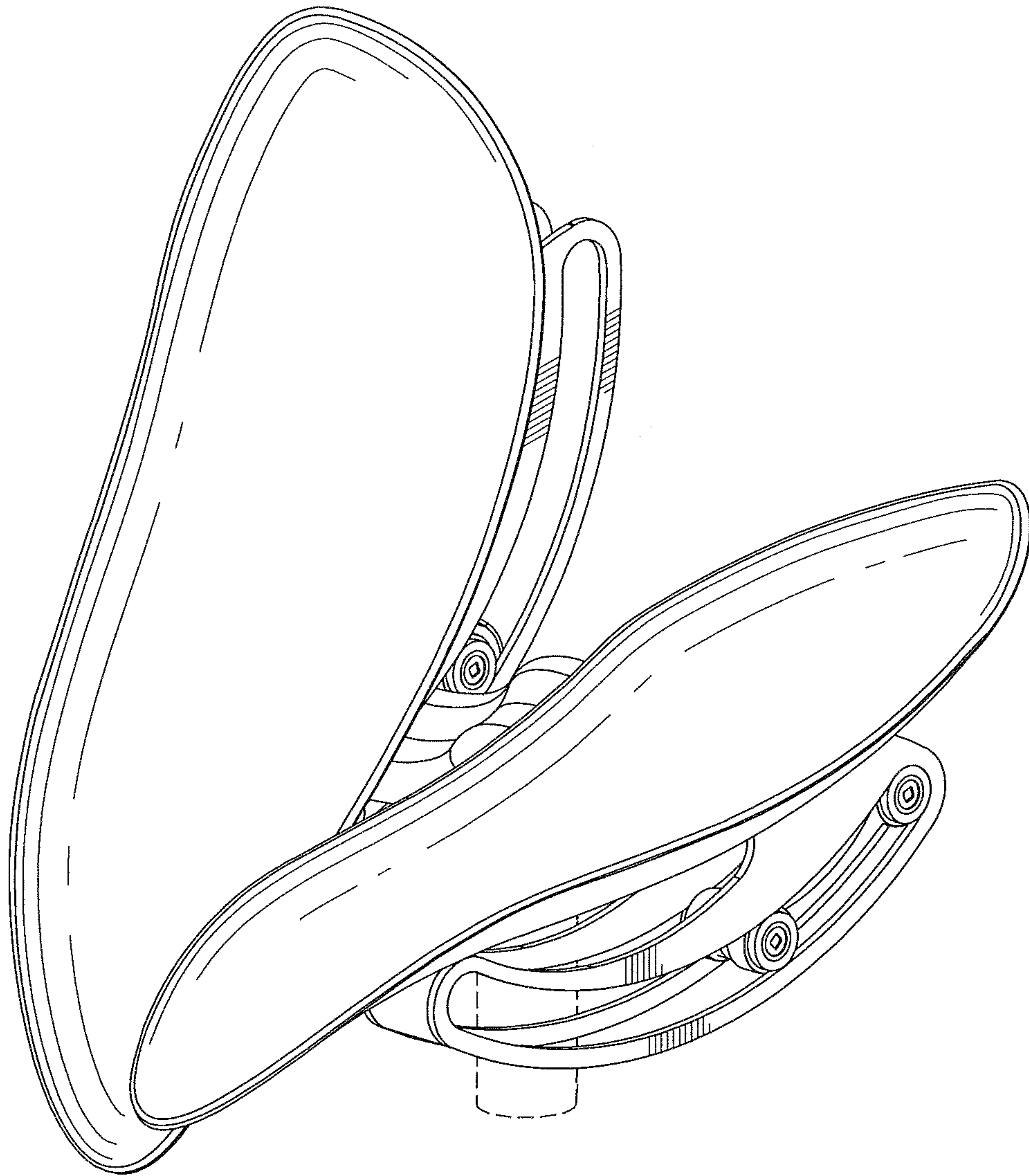

FIG. 1

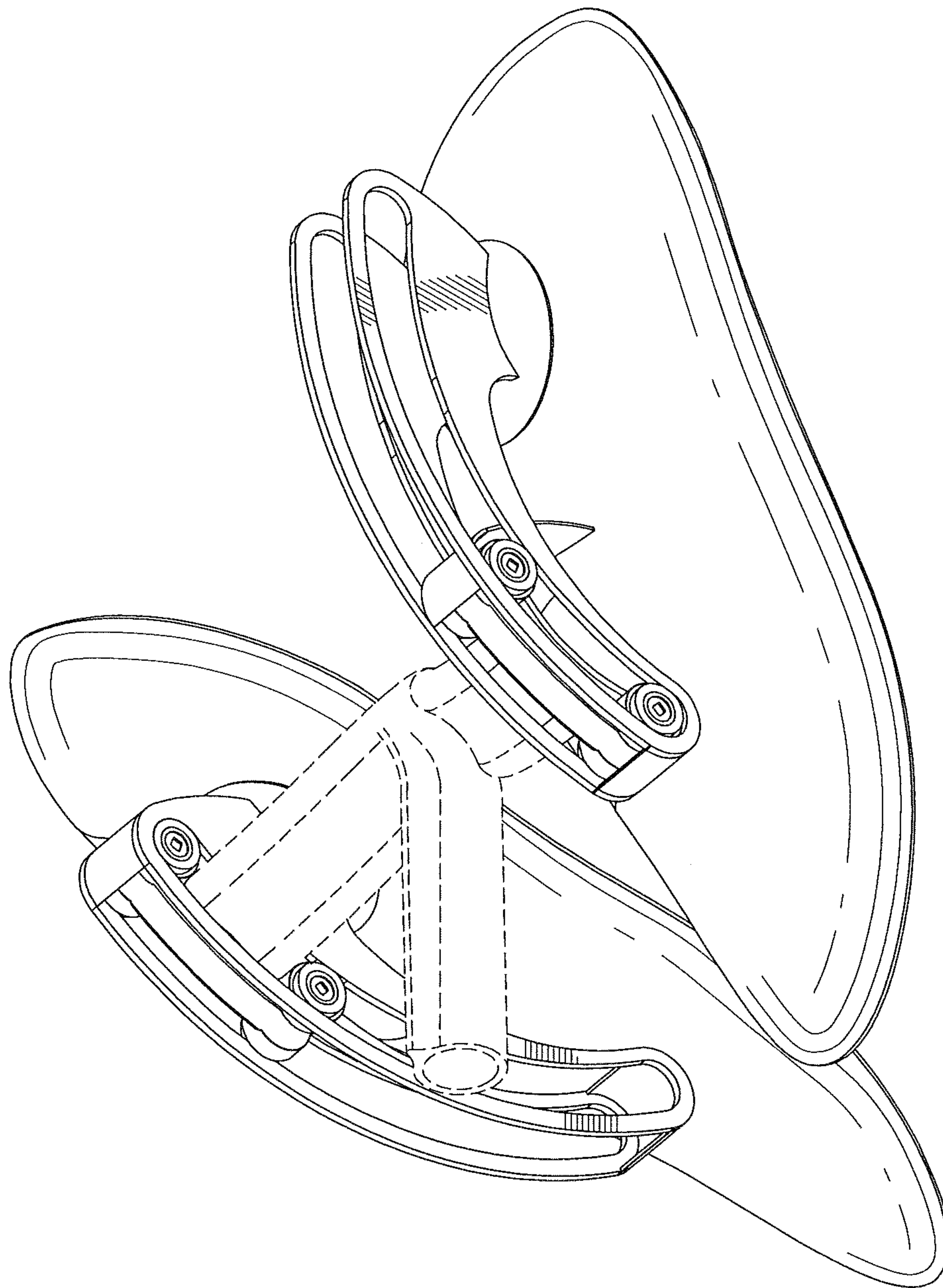
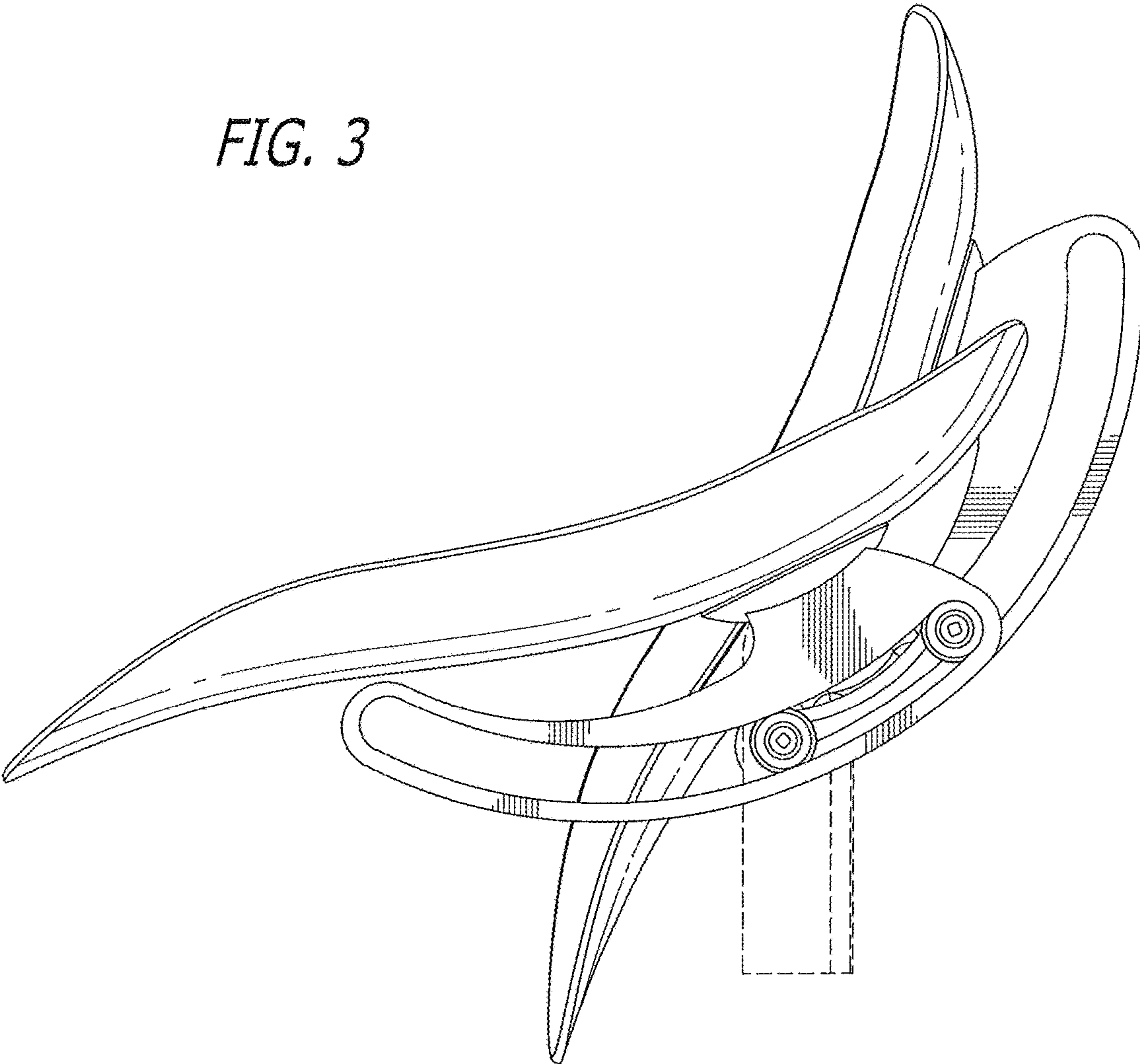

FIG. 2

FIG. 3



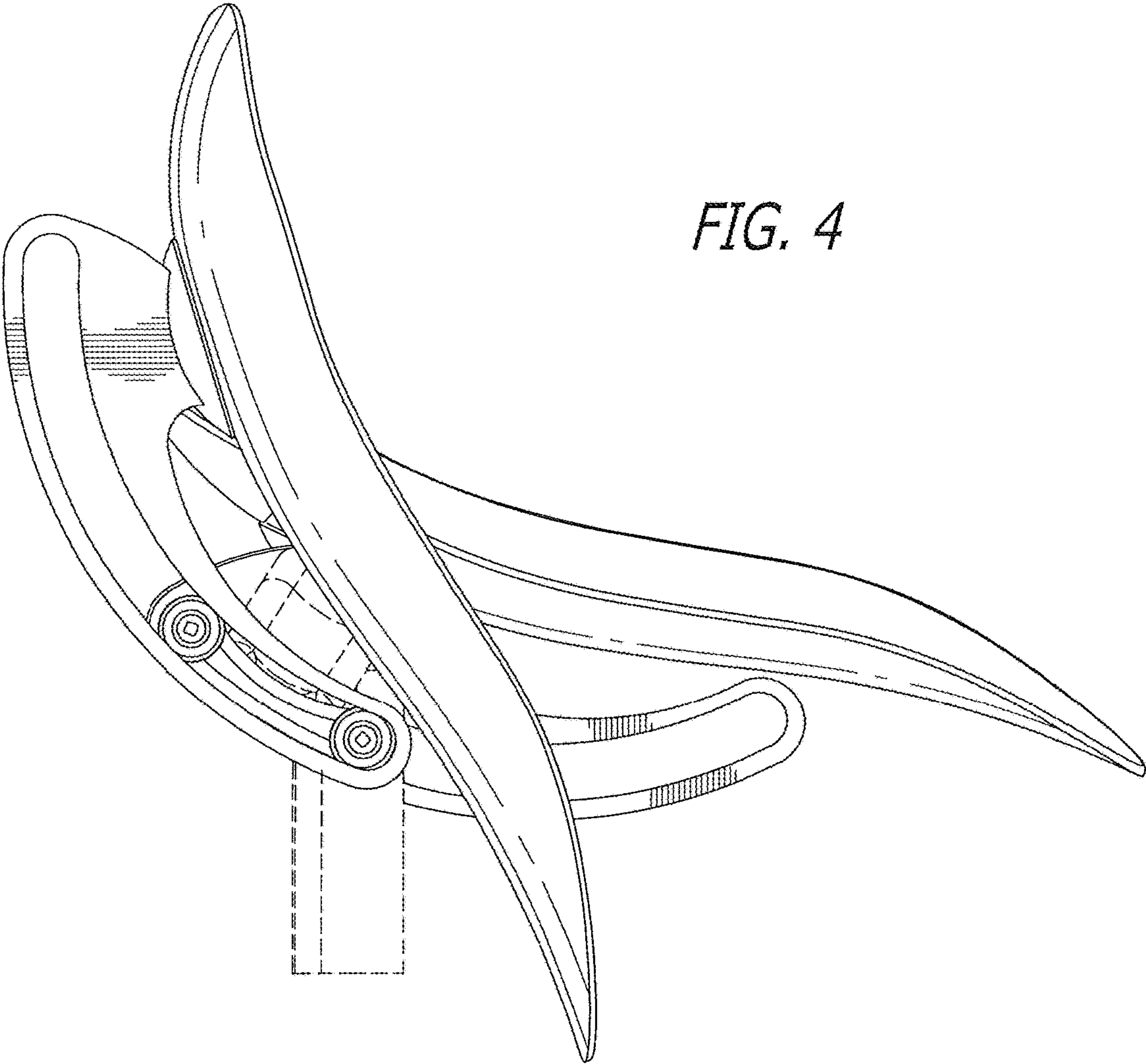

FIG. 4

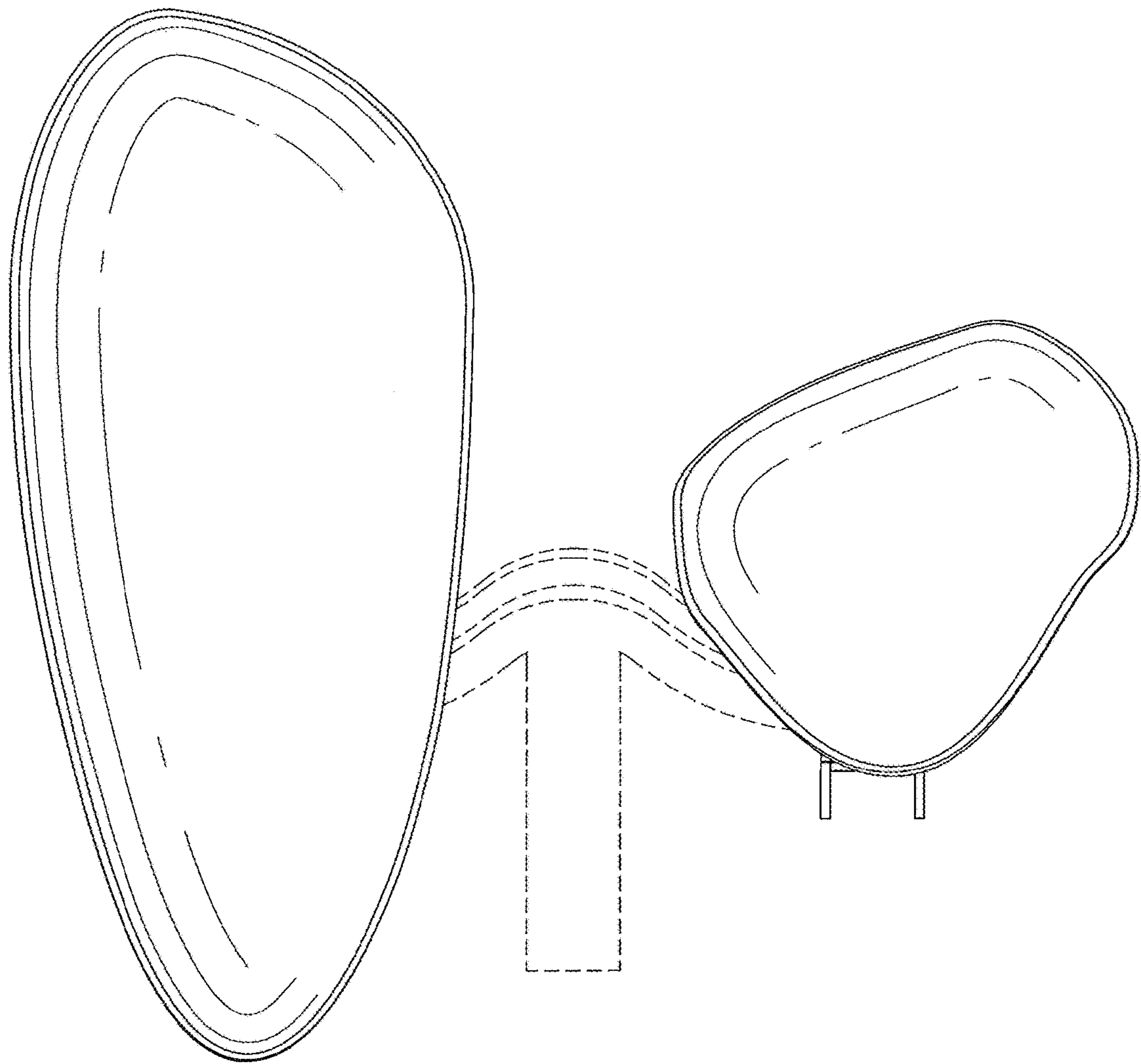

FIG. 5

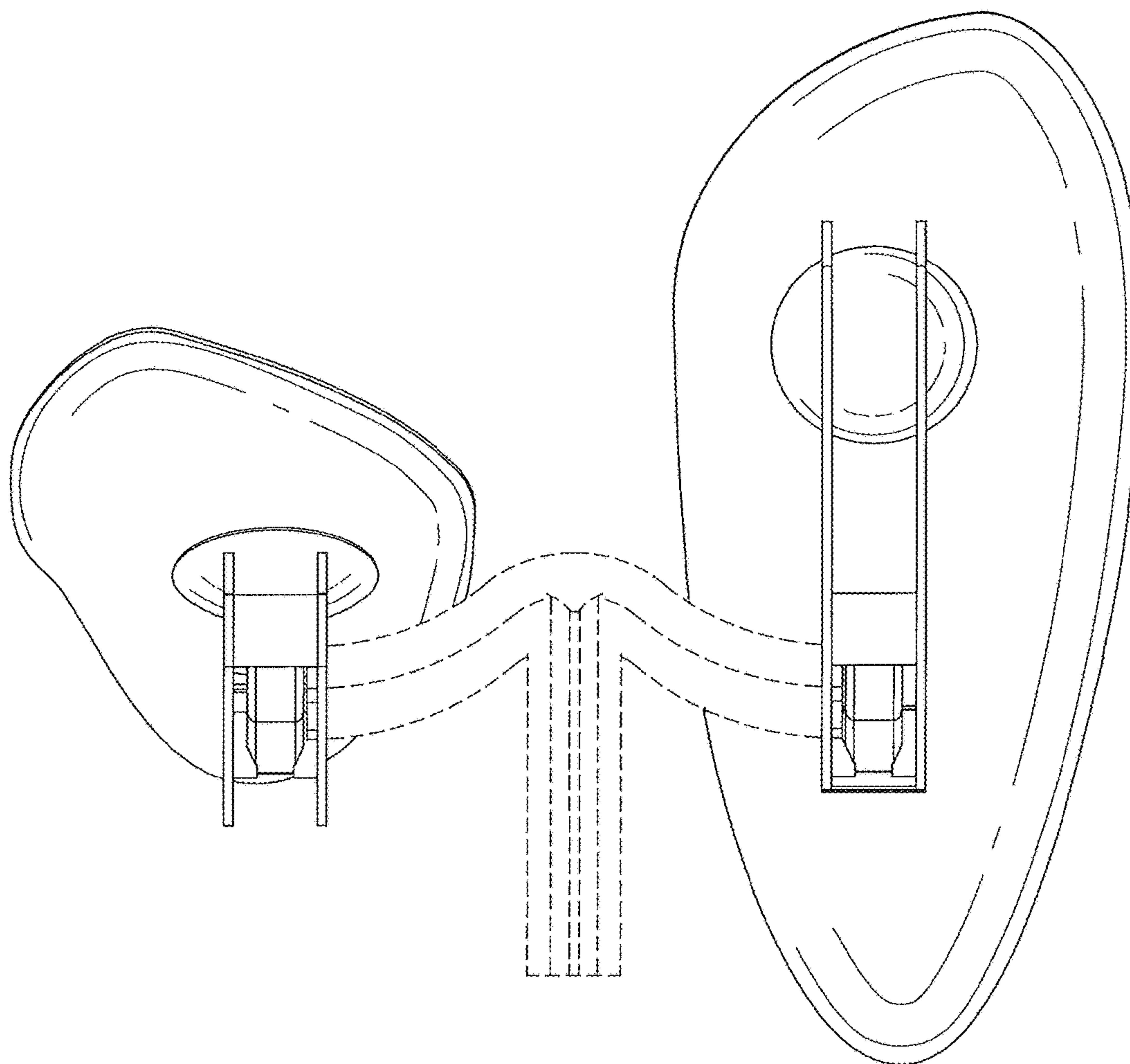

FIG. 6

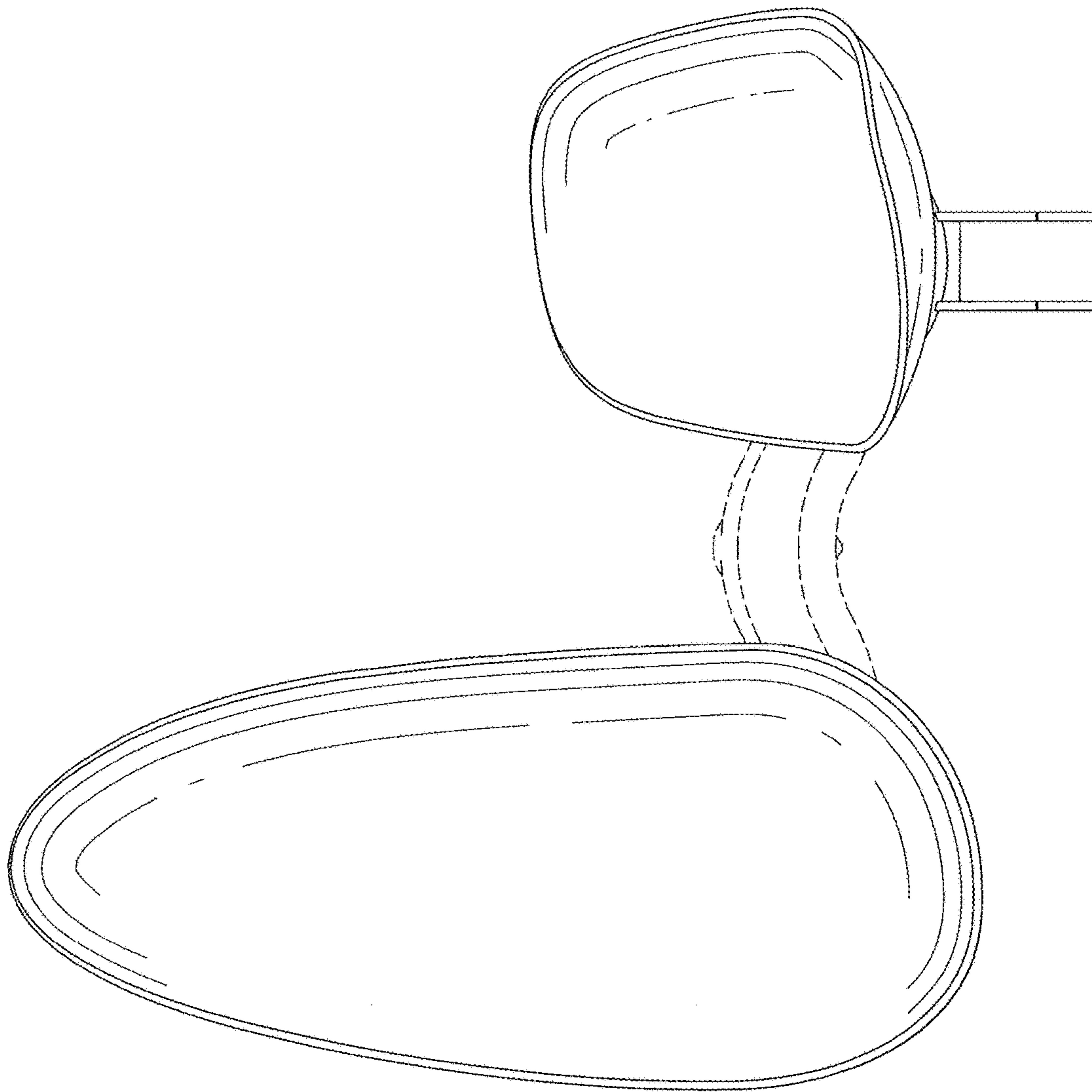

FIG. 7

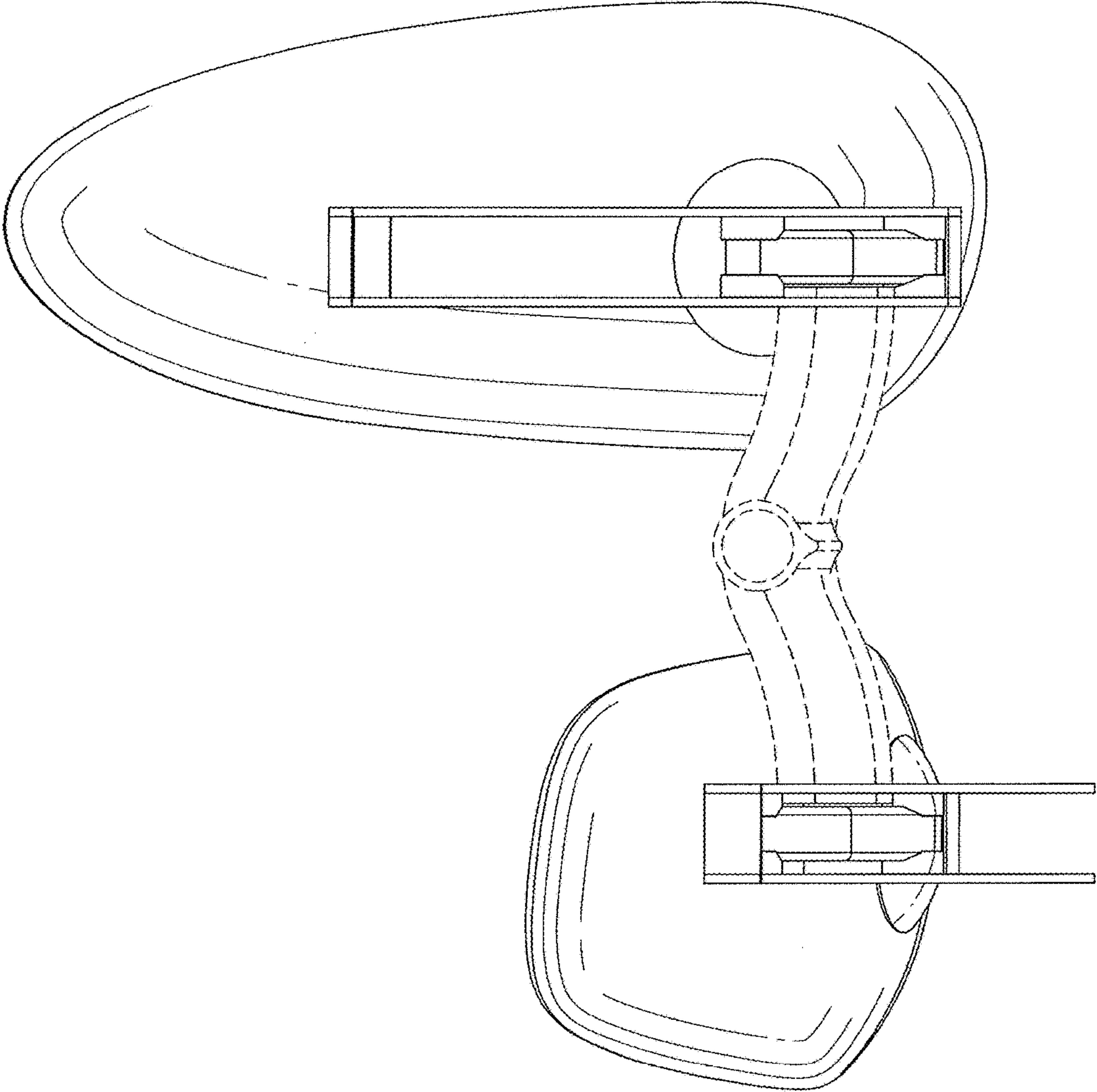

FIG. 8