



US00D809453S

(12) **United States Design Patent** (10) **Patent No.:** **US D809,453 S**
Sato (45) **Date of Patent:** **** Feb. 6, 2018**

(54) **TIRE**
(71) Applicant: **Toyo Tire & Rubber Co., Ltd.**,
Osaka-shi, Osaka (JP)
(72) Inventor: **Yoshiki Sato**, Osaka (JP)
(73) Assignee: **Toyo Tire & Rubber Co., Ltd.**, Osaka
(JP)

D627,714 S * 11/2010 Miyazaki D12/605
D627,715 S * 11/2010 Umstot D12/605
D638,354 S * 5/2011 Strader D12/605
D639,727 S * 6/2011 Tokizaki D12/605
D640,188 S * 6/2011 Strader D12/605
D663,259 S * 7/2012 Umstot D12/605
D681,546 S * 5/2013 Sato D12/605
D735,127 S 7/2015 Kato

(Continued)

(**) Term: **15 Years**

(21) Appl. No.: **29/587,622**

(22) Filed: **Dec. 14, 2016**

(30) **Foreign Application Priority Data**

Jul. 14, 2016 (JP) 2016-015092

(51) **LOC (11) Cl.** **12-15**

(52) **U.S. Cl.**
USPC **D12/604**

(58) **Field of Classification Search**
USPC D12/605, 604
CPC B60C 13/00; B60C 1/00
See application file for complete search history.

(56) **References Cited**

U.S. PATENT DOCUMENTS

D500,473 S * 1/2005 Boggs D12/605
D554,577 S * 11/2007 Miyazaki D12/605
D568,235 S * 5/2008 Dixon D12/605
D575,222 S * 8/2008 Fujita D12/605
D577,661 S * 9/2008 Umstot D12/605
D588,530 S * 3/2009 Shondel D12/605
D588,533 S * 3/2009 Shondel D12/605
D595,643 S * 7/2009 Ochi D12/605
D596,116 S * 7/2009 Fujita D12/605
D597,024 S * 7/2009 Ochi D12/605
D609,176 S * 2/2010 Fujita D12/605
D609,177 S * 2/2010 Osaka D12/605
D611,894 S * 3/2010 Scheifele D12/605

FOREIGN PATENT DOCUMENTS

JP 1434191 2/2012
JP 1440125 5/2013

Primary Examiner — George D. Kirschbaum

Assistant Examiner — Clese Moore, Jr.

(74) *Attorney, Agent, or Firm* — Sterne, Kessler,
Goldstein & Fox P.L.L.C.

(57) **CLAIM**

The ornamental design for a tire, as shown and described.

DESCRIPTION

FIG. 1 is a front perspective view of a tire showing the claimed design;

FIG. 2 is a front view thereof;

FIG. 3 is a rear view thereof;

FIG. 4 is a top plan view thereof, to which the bottom plan view is symmetrical;

FIG. 5 is a left side view thereof, the right side view being a mirror image thereof;

FIG. 6 is an enlarged view of the portion between 6-6 and 6'-6' in FIG. 2; and,

FIG. 7 is an enlarged cross-sectional view taken along line 7"-7" in FIG. 6, within the portion 7'-7' in FIG. 6 to line 7-7 in FIG. 4.

In the drawings, the broken lines showing portions of the tire tread, sidewall, and inner bead depict portions of the tire that form no part of the claimed design.

1 Claim, 7 Drawing Sheets

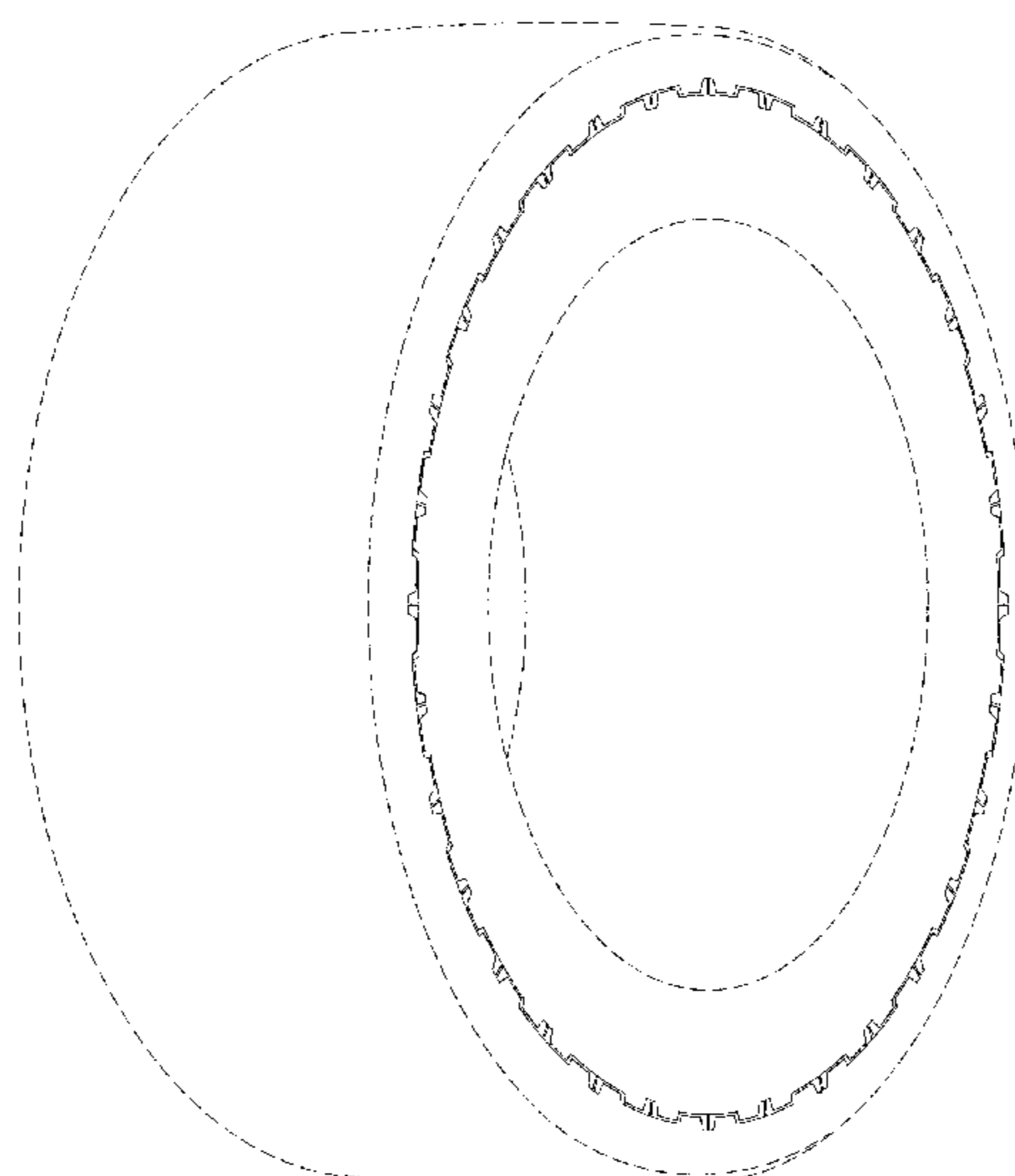

(56)

References Cited

U.S. PATENT DOCUMENTS

D757,644 S * 5/2016 Wieland D12/605
D772,799 S * 11/2016 Shondel D12/605

* cited by examiner

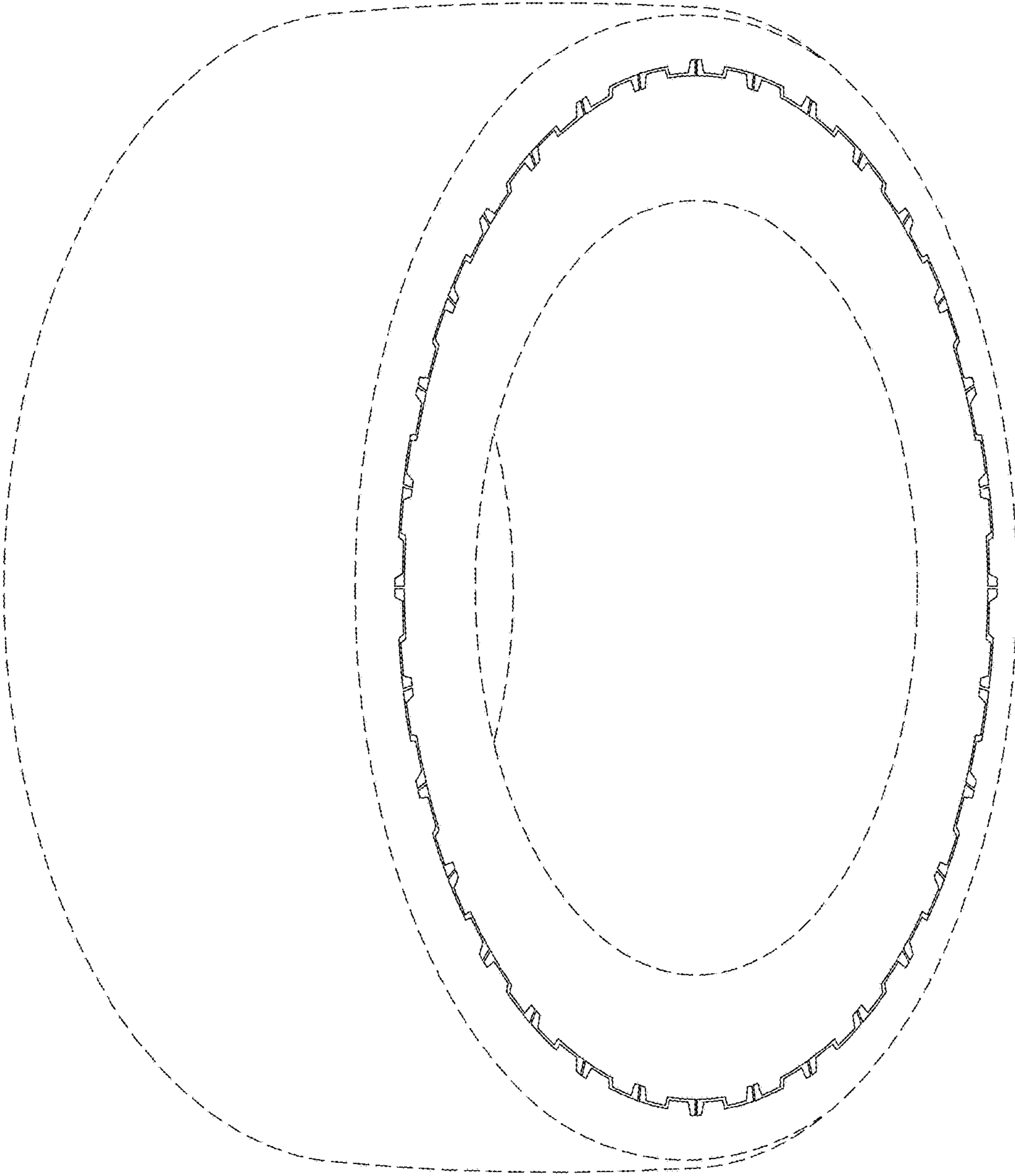

FIG. 1

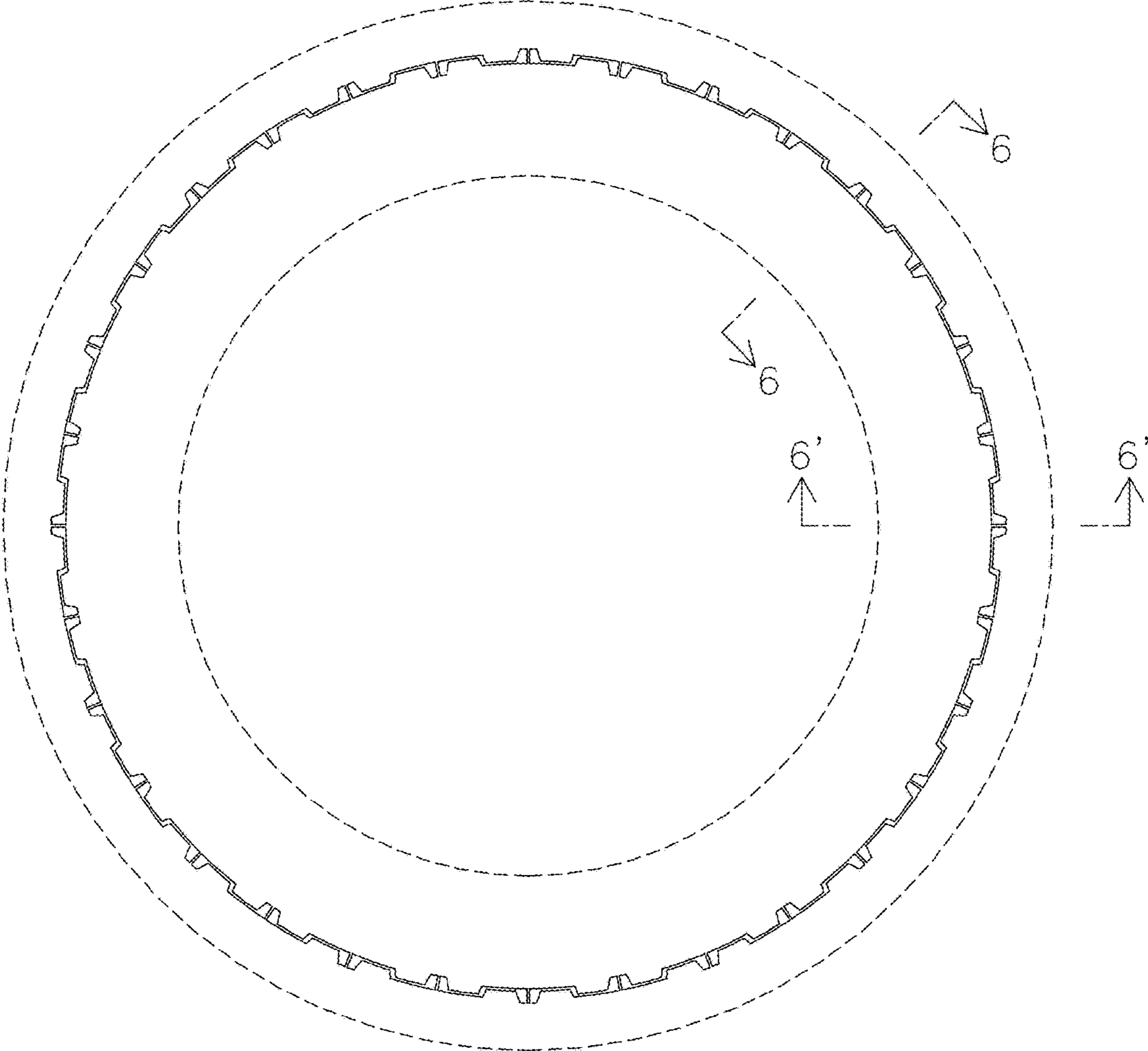

FIG. 2

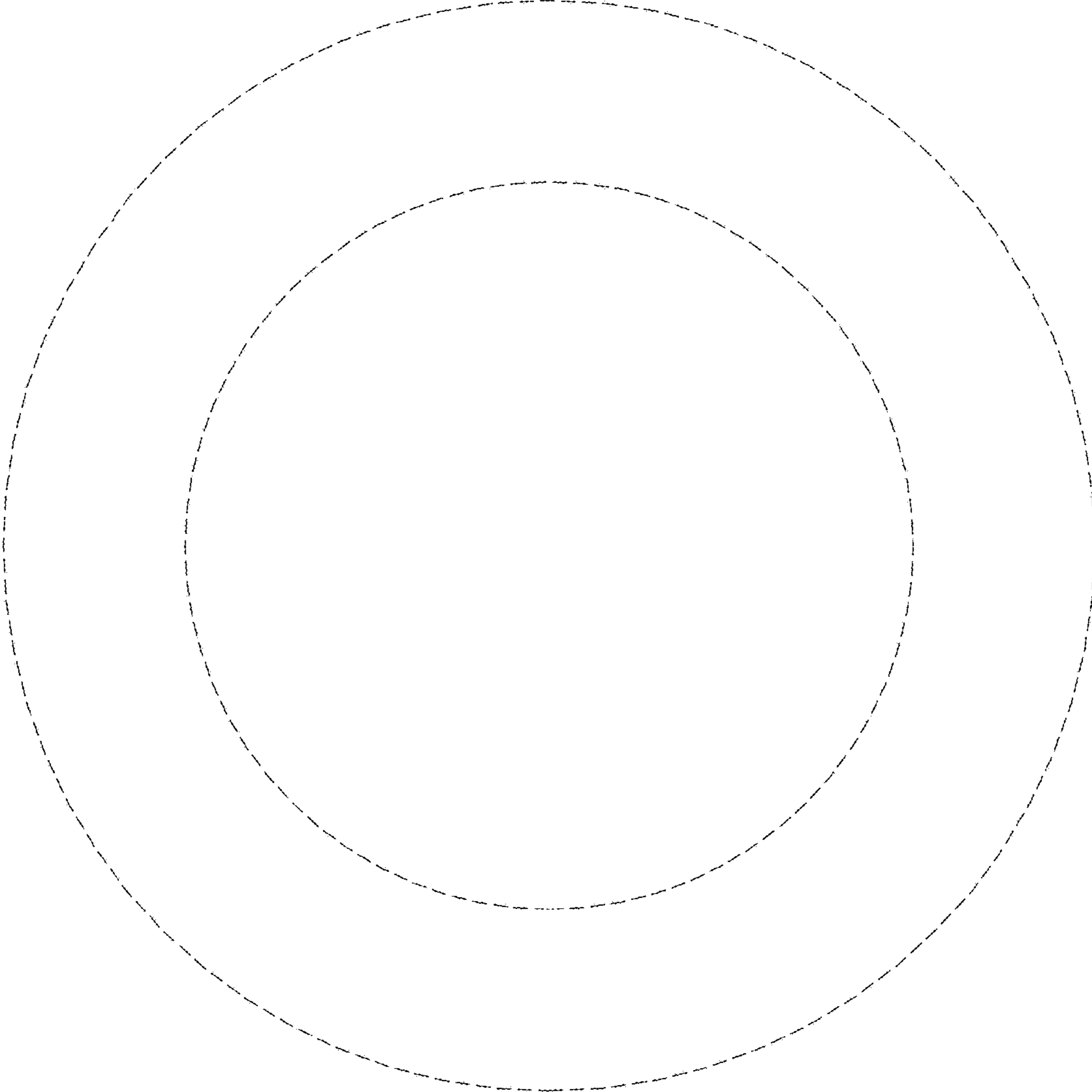

FIG. 3

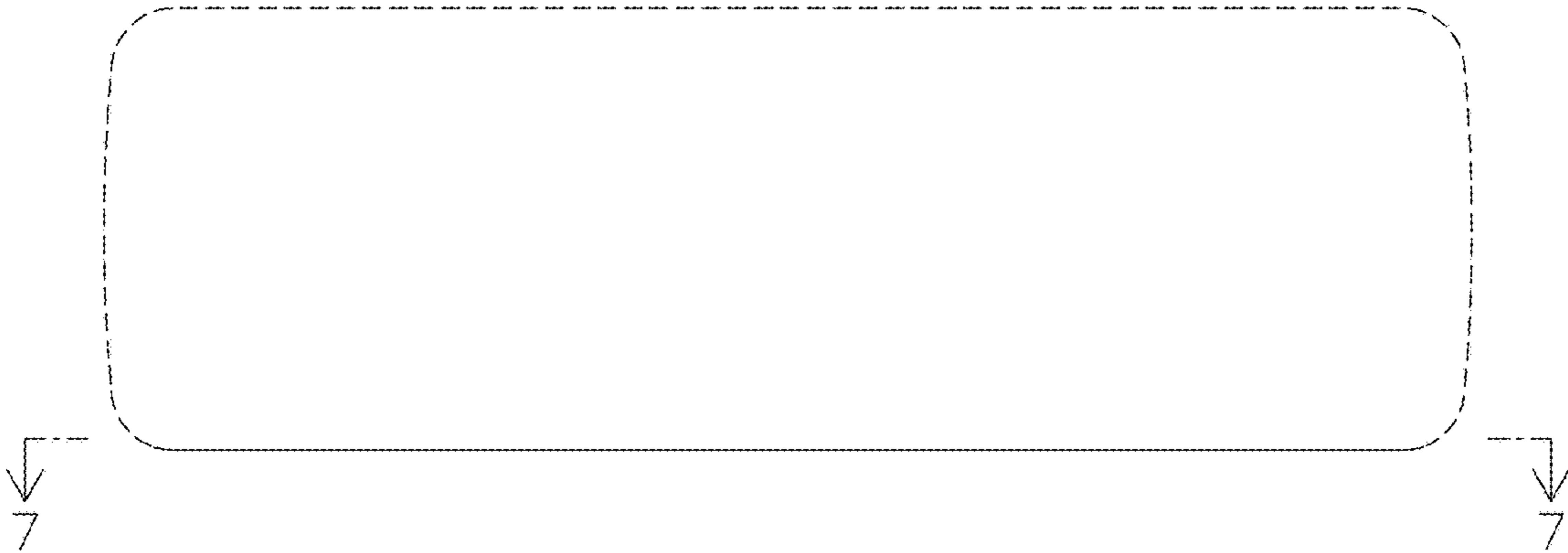

FIG. 4

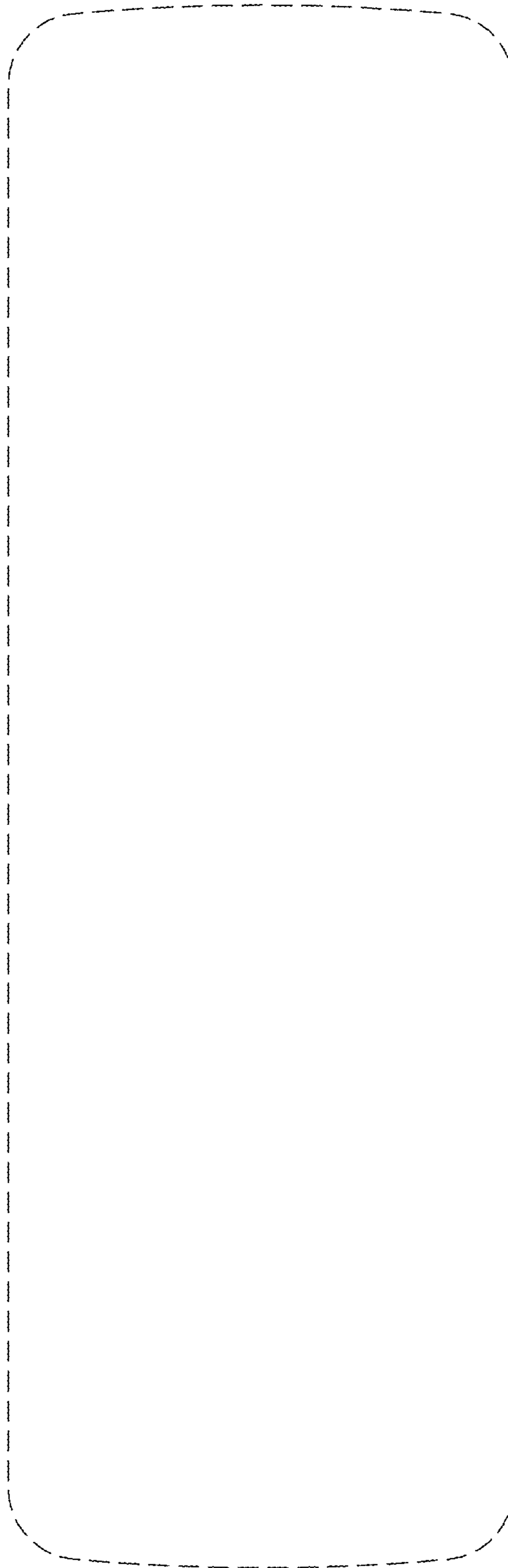

FIG. 5

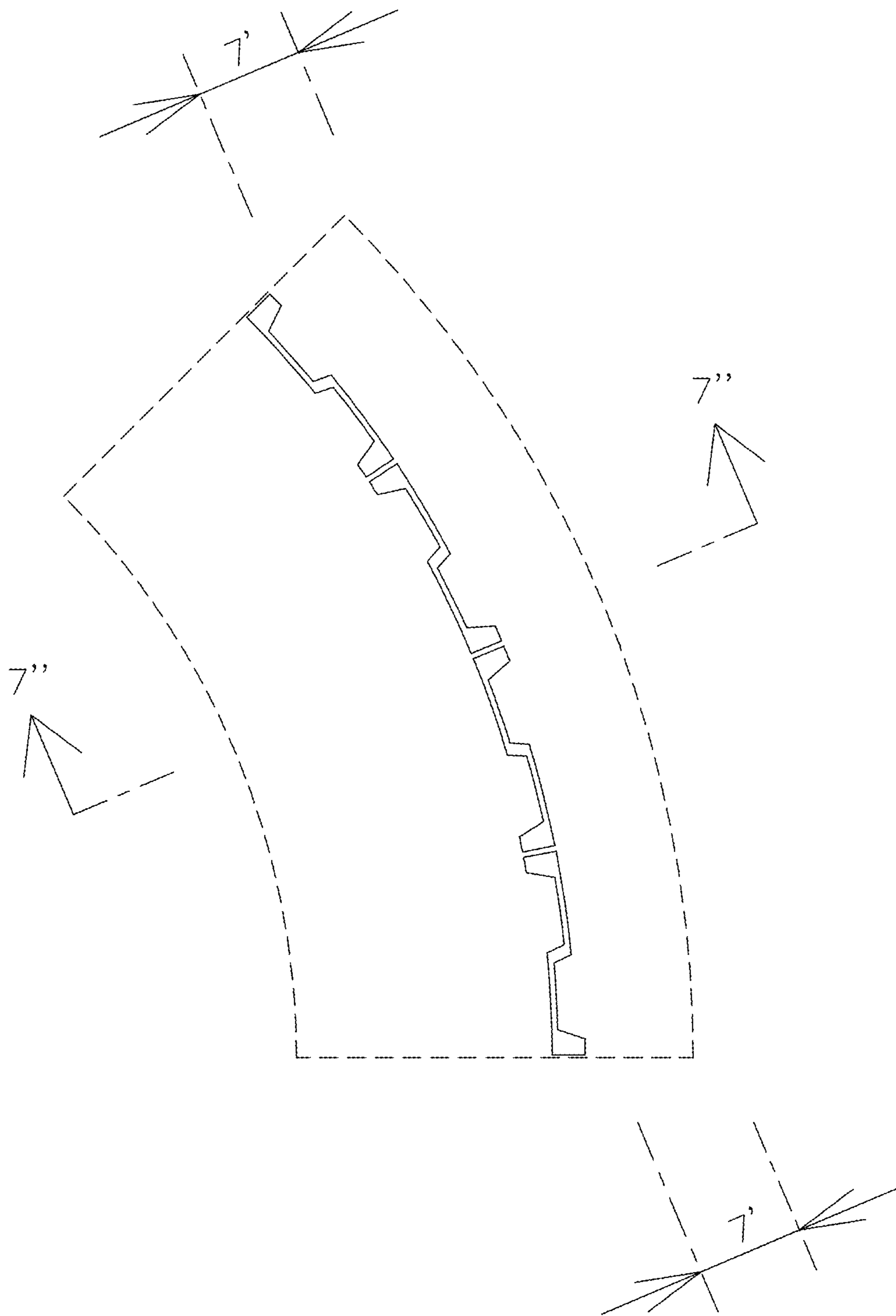

FIG. 6

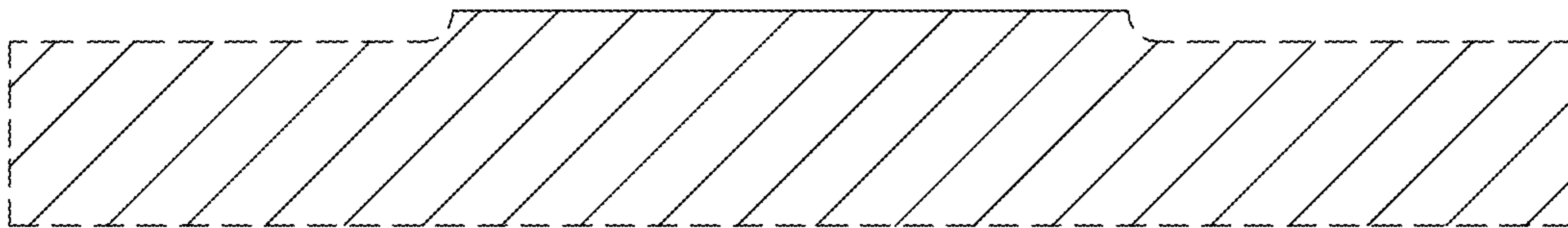

FIG. 7