



US00D809435S

(12) **United States Design Patent**  
**Gertner**

(10) **Patent No.:** **US D809,435 S**

(45) **Date of Patent:** **\*\* Feb. 6, 2018**

(54) **BIKE RACK**

(71) Applicant: **Steven Gertner**, Brooklyn, NY (US)

(72) Inventor: **Steven Gertner**, Brooklyn, NY (US)

(\*\*) Term: **15 Years**

(21) Appl. No.: **29/570,476**

(22) Filed: **Jul. 8, 2016**

(51) **LOC (11) Cl.** ..... **08-10**

(52) **U.S. Cl.**  
USPC ..... **D12/115; D12/408**

(58) **Field of Classification Search**  
USPC ..... D12/115, 120, 408  
CPC .. B62H 3/00; B62H 3/10; B62D 43/02; B60R  
9/06; F16M 13/00  
See application file for complete search history.

(56) **References Cited**

**U.S. PATENT DOCUMENTS**

3,782,559	A *	1/1974	Wright	.....	B62H 3/12 211/113
D240,351	S *	6/1976	Generalis	.....	D12/115
4,392,572	A *	7/1983	Bernard	.....	B62H 3/12 211/19
D270,879	S *	10/1983	Jacobson	.....	D6/553
4,552,270	A *	11/1985	Lentz	.....	B62H 3/12 211/17
4,555,029	A *	11/1985	Fiol	.....	B62H 3/10 211/189
5,984,111	A *	11/1999	Pennella	.....	B62H 3/00 211/19
D660,749	S *	5/2012	Strayer	.....	D12/115

D661,623	S *	6/2012	Strayer	.....	D12/115
D670,209	S *	11/2012	Graham	.....	D12/115
D684,505	S *	6/2013	Stavinga	.....	D12/115
D689,410	S *	9/2013	Nadel	.....	D12/115
D694,674	S *	12/2013	Higgins	.....	D12/115
D743,871	S *	11/2015	Freet	.....	D12/408
D753,577	S *	4/2016	Duncan	.....	D12/115
D780,640	S *	3/2017	Hudson, Jr.	.....	D12/115
D784,245	S *	4/2017	Mayers	.....	D12/115

\* cited by examiner

*Primary Examiner* — Darlington Ly

(74) *Attorney, Agent, or Firm* — Lerner, David, Littenberg & Krumholz & Mentlik, LLP

(57) **CLAIM**

The ornamental design for a bike rack, as shown and described.

**DESCRIPTION**

FIG. 1 is a top, front, and right side perspective view of a bike rack showing my new design, wherein a cover plate is shown spaced apart from its associated mounting plate; FIG. 2 is a top, front, and right side perspective view thereof, in which the cover plate is shown attached to its associated mounting plate; FIG. 3 is a front elevational view thereof; FIG. 4 is a rear elevational view thereof; FIG. 5 is a left side elevational view thereof; FIG. 6 is a right side elevational view thereof; FIG. 7 is a top plan view thereof; and, FIG. 8 is a bottom plan view thereof. The broken lines shown in the drawings represent portions of the bike rack that form no part of the claimed design.

**1 Claim, 4 Drawing Sheets**

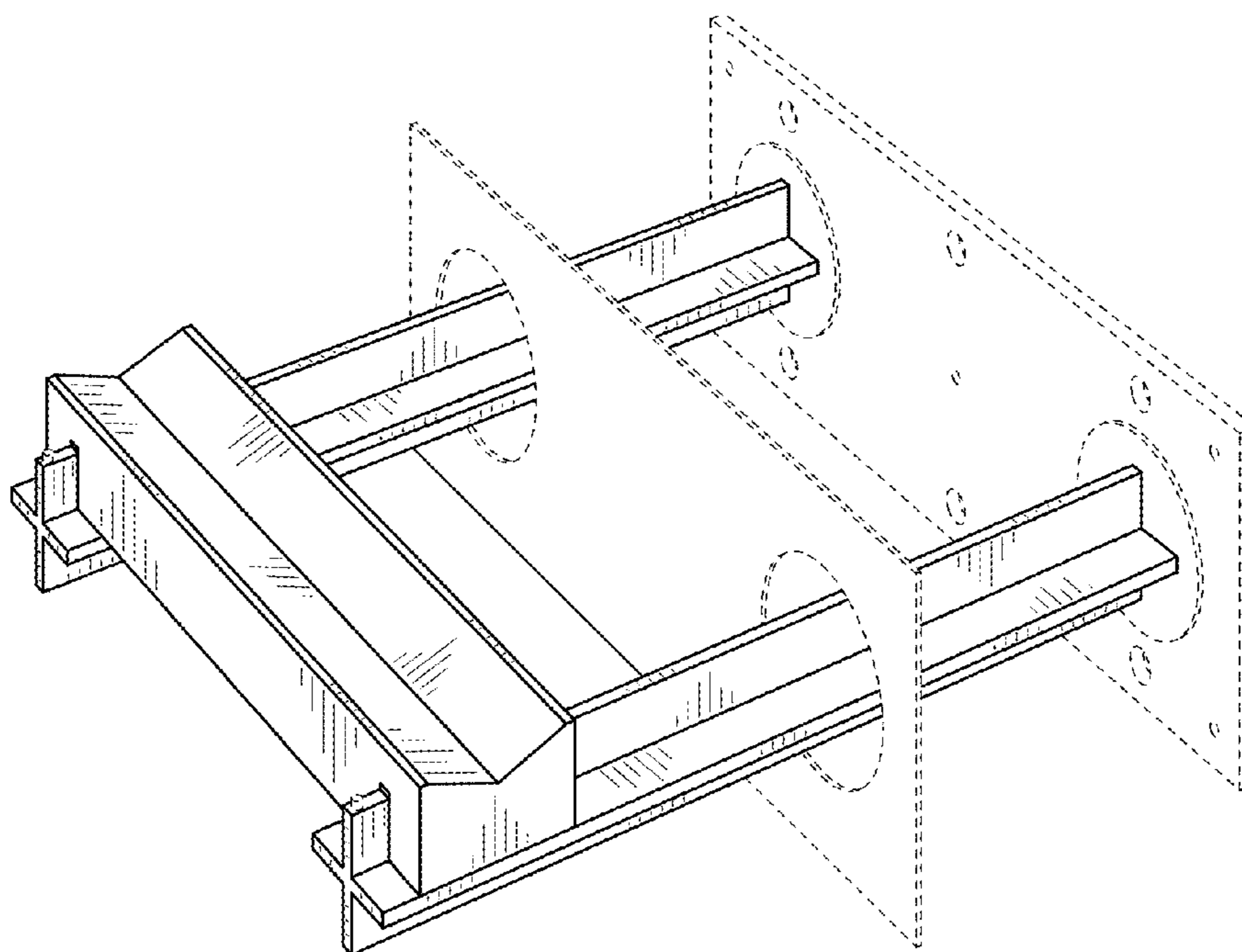

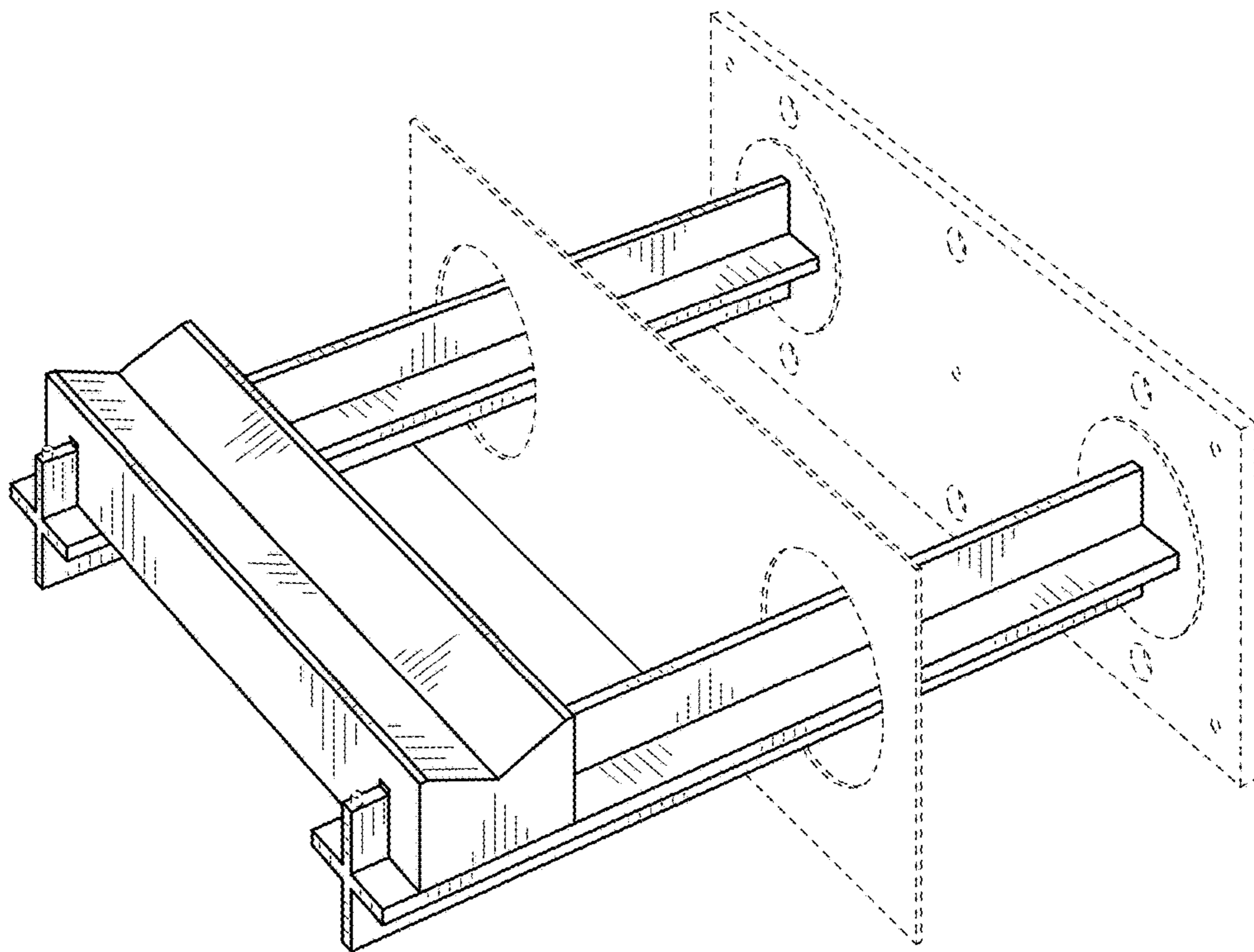

FIG. 1

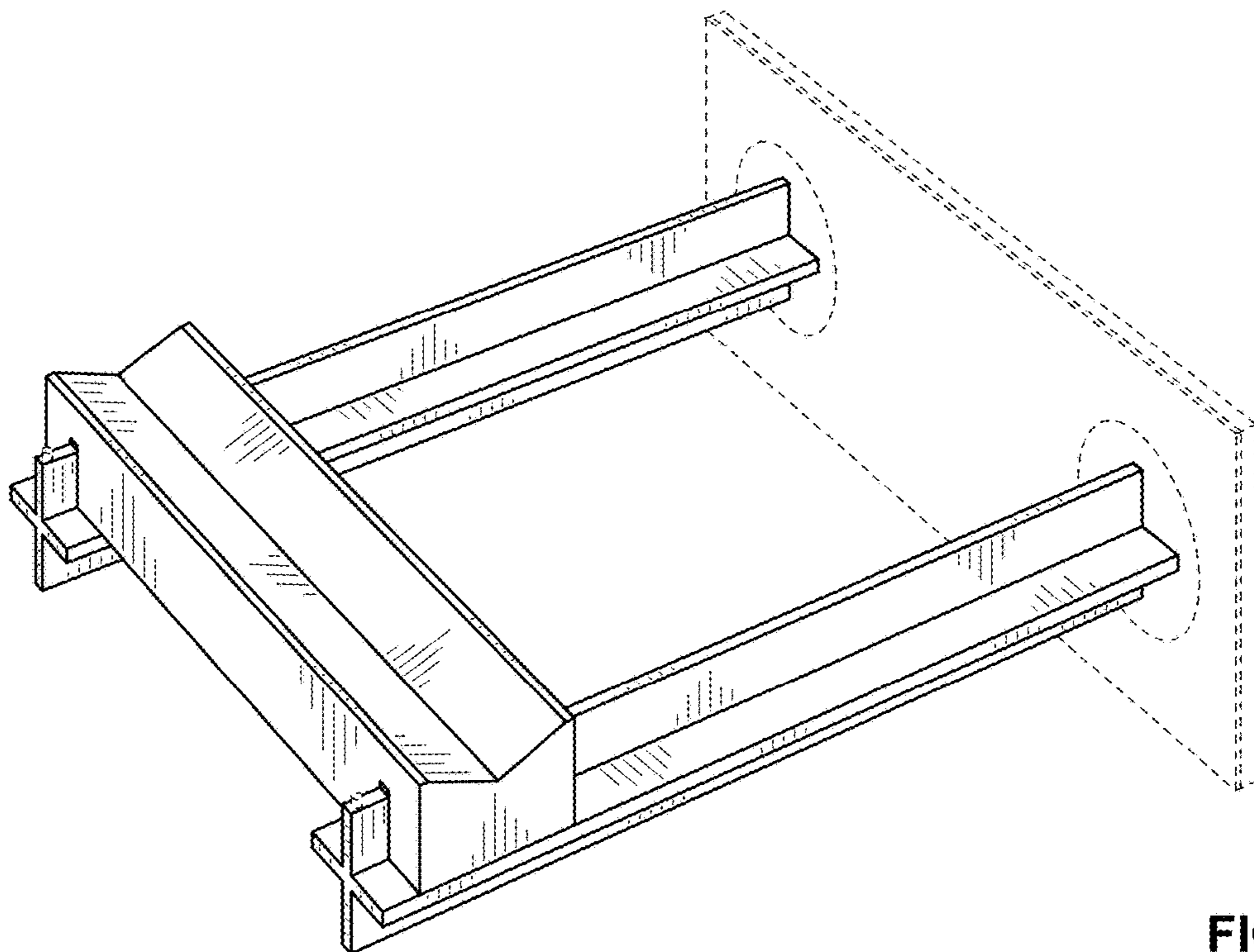

FIG. 2

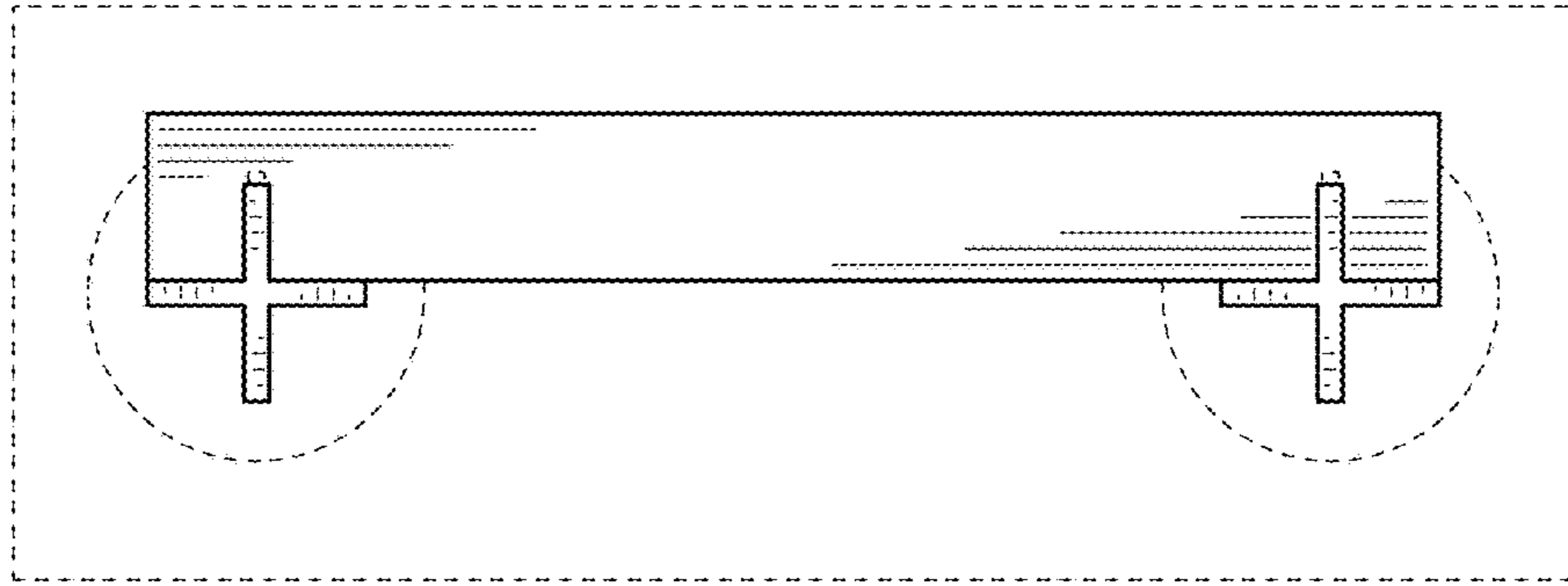

FIG. 3

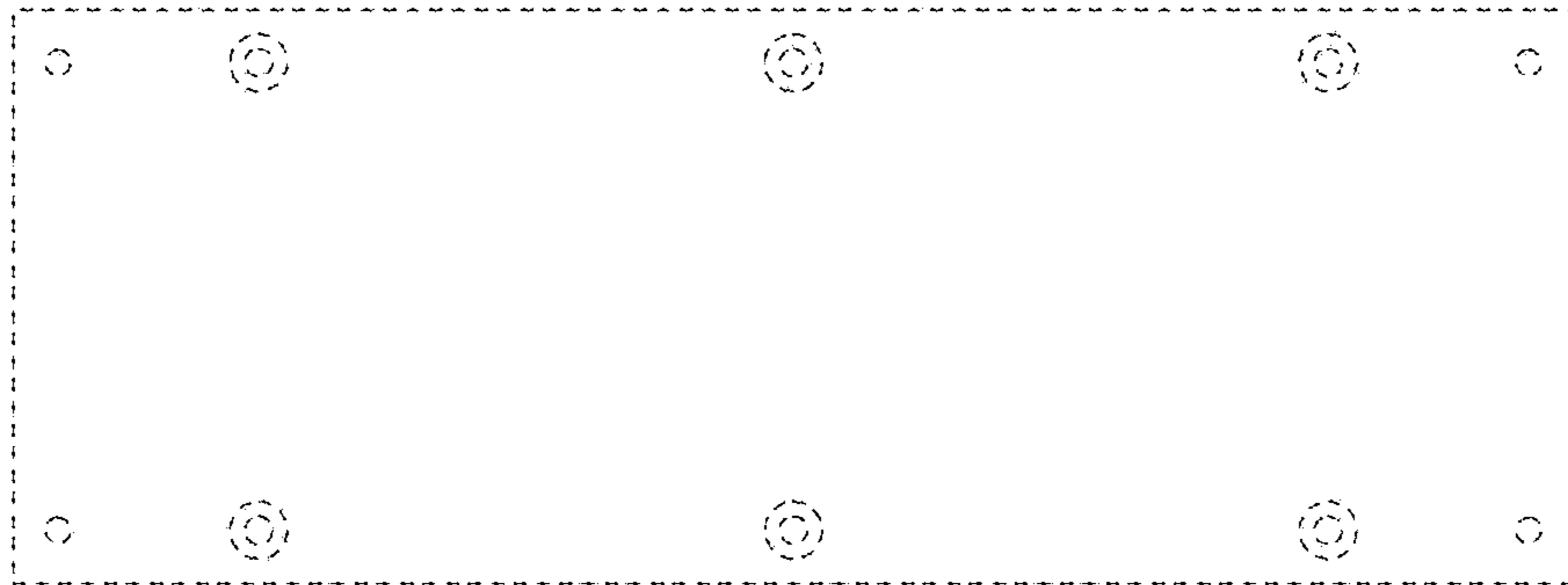

FIG. 4

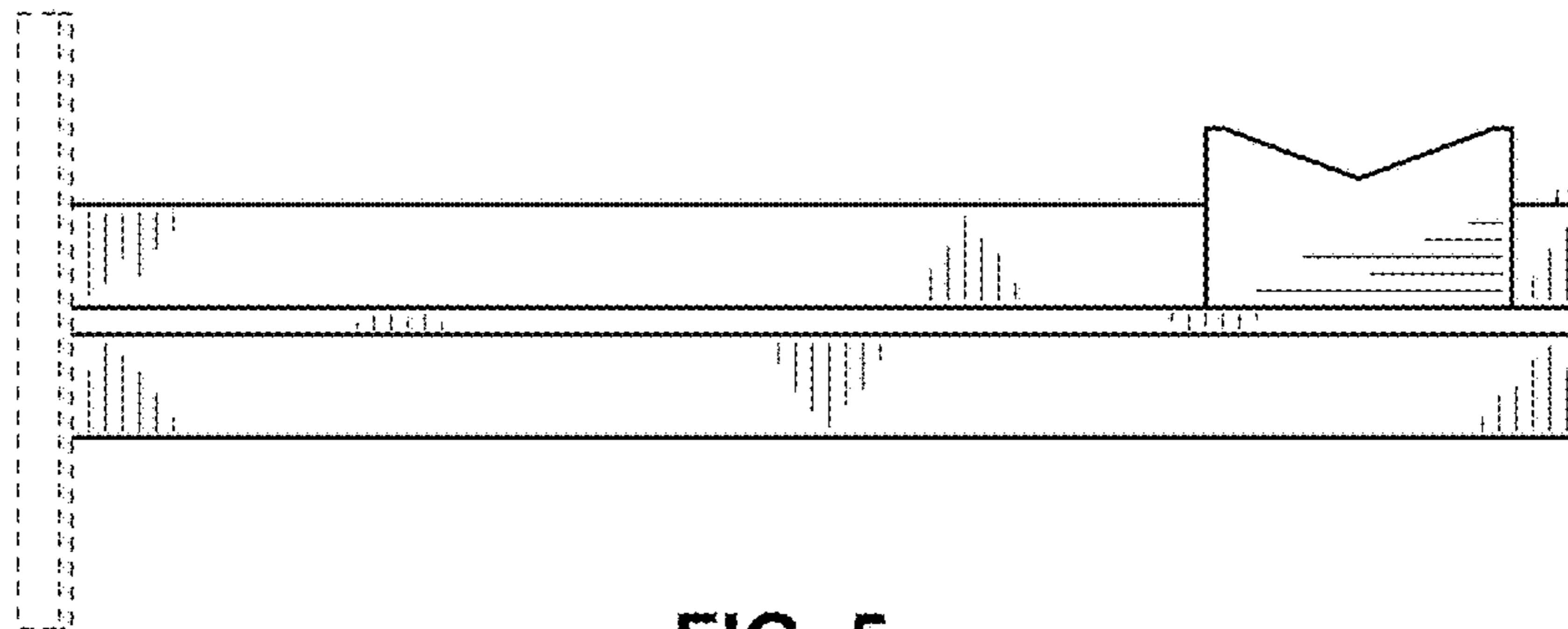

FIG. 5

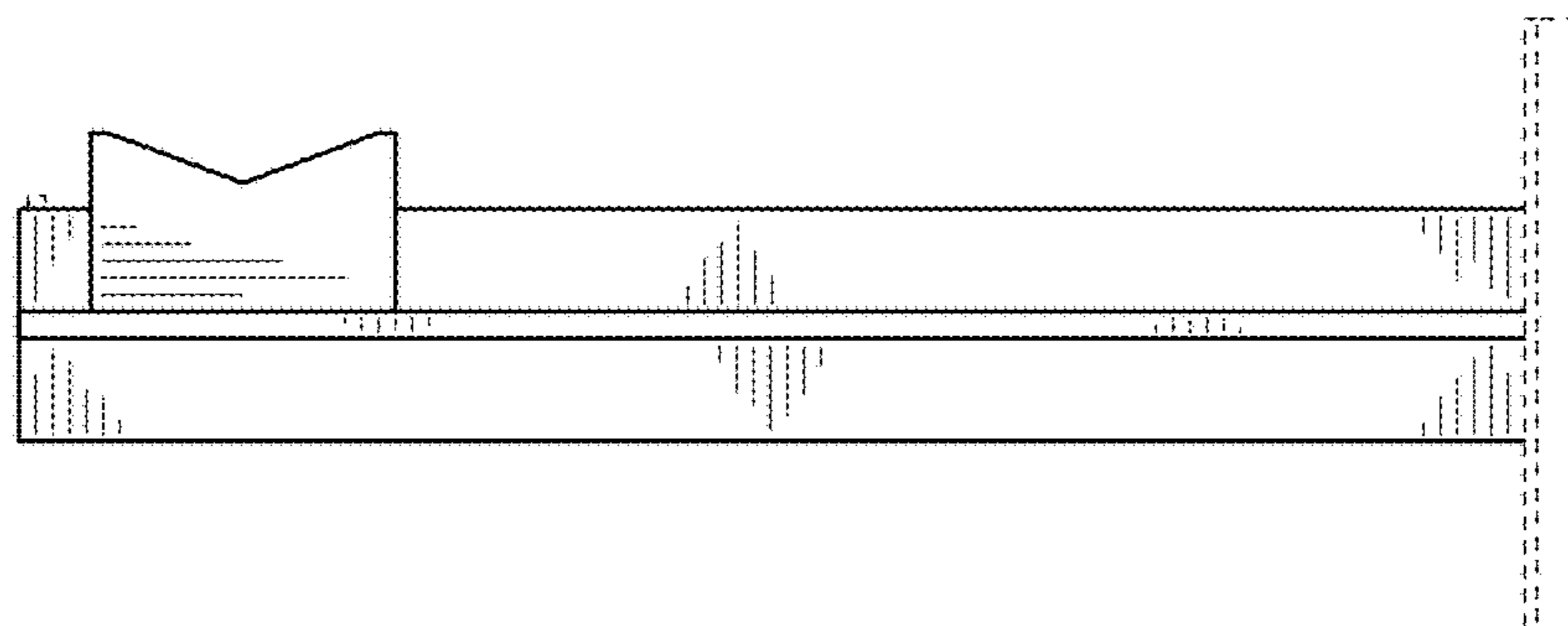

FIG. 6

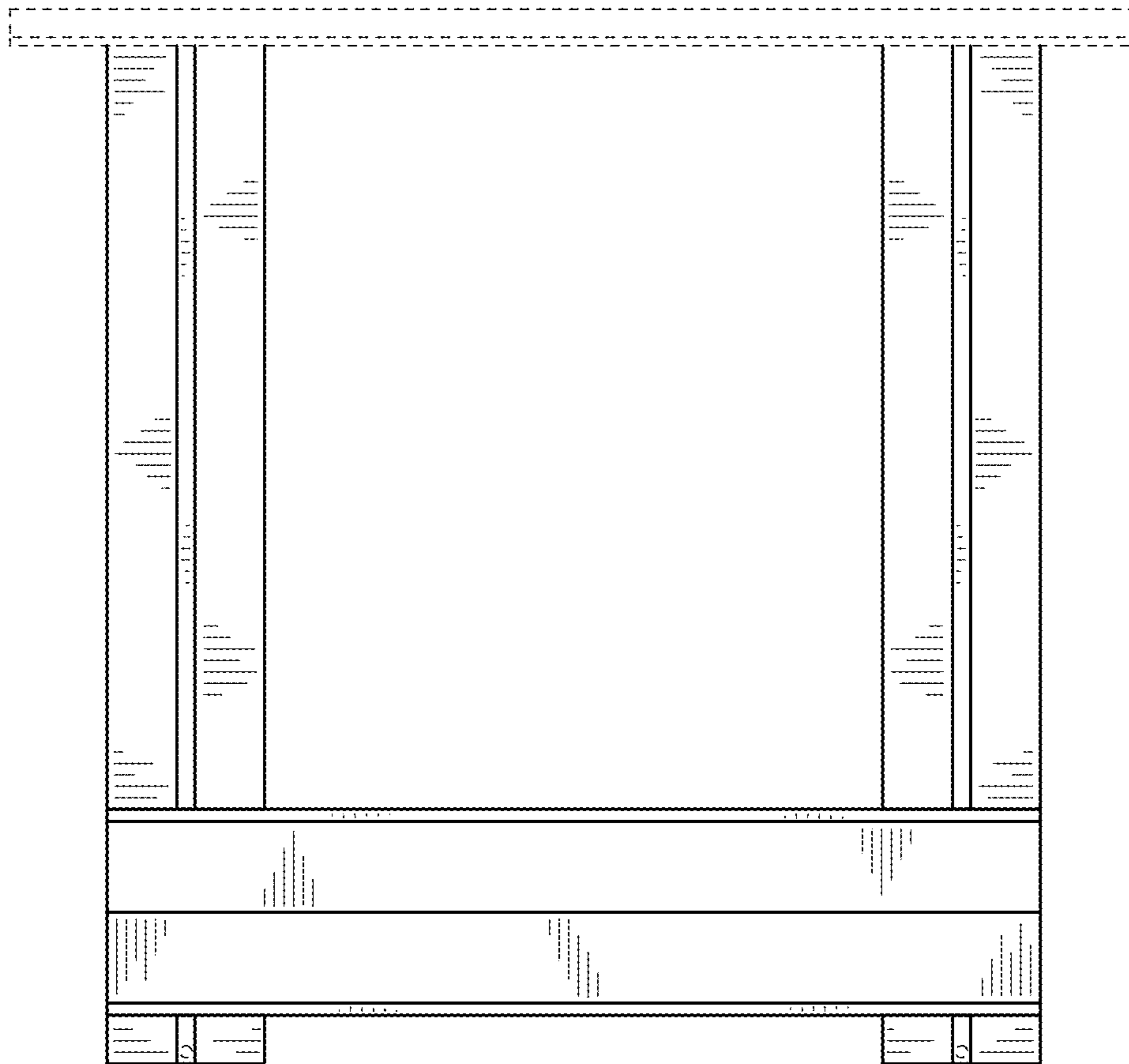

FIG. 7

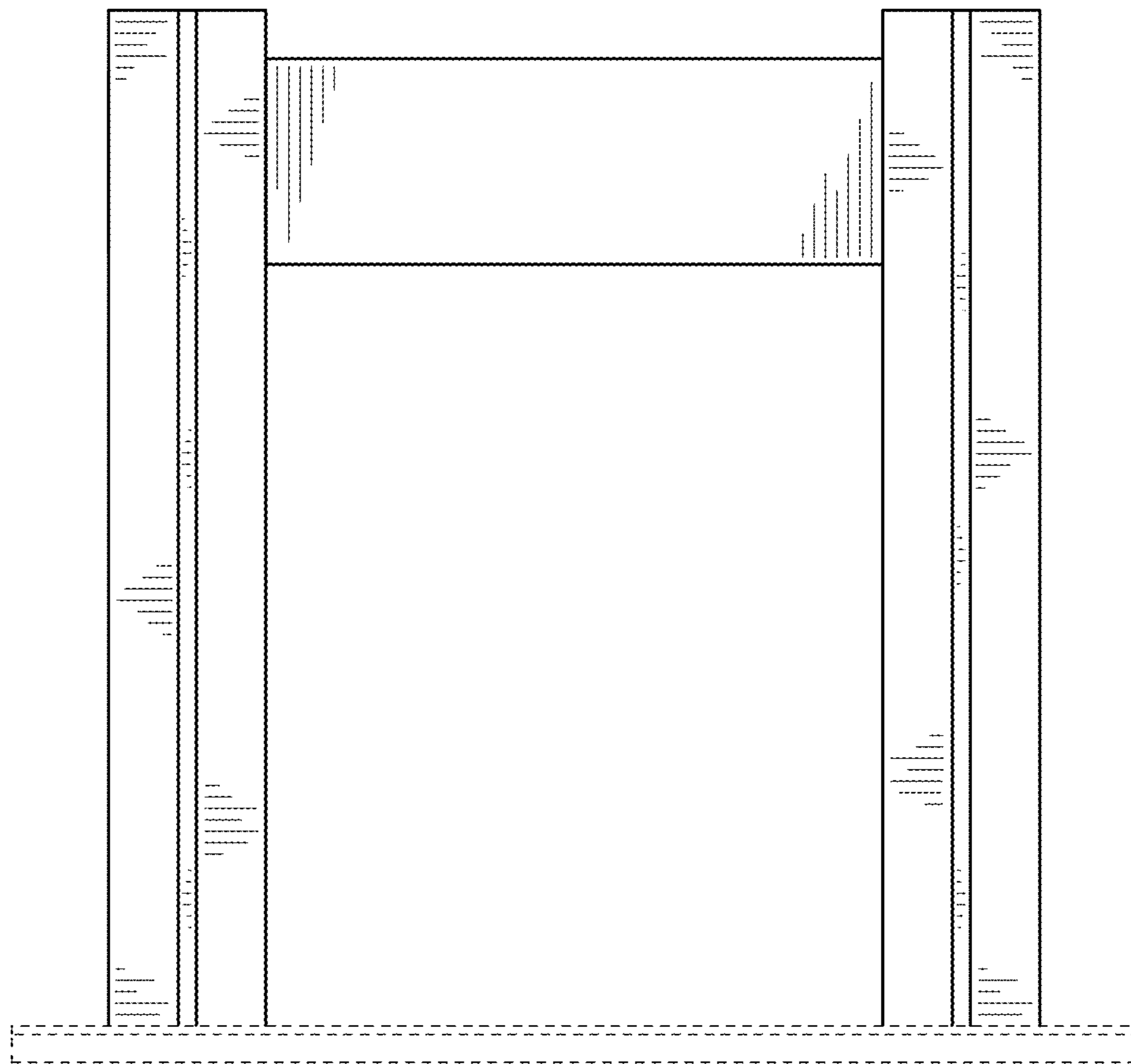

FIG. 8