



US00D809381S

(12) **United States Design Patent** (10) **Patent No.:** **US D809,381 S**
DeLaGrange (45) **Date of Patent:** **** *Feb. 6, 2018**

(54) **DISPLAY BOX**

- (71) Applicant: **Insurance Lounge, Inc.**, Grants Pass, OR (US)
- (72) Inventor: **Michael DeLaGrange**, Grants Pass, OR (US)
- (73) Assignee: **Insurance Lounge, Inc.**, Grants Pass, OR (US)
- (*) Notice: This patent is subject to a terminal disclaimer.
- (**) Term: **14 Years**

- (21) Appl. No.: **29/513,258**
- (22) Filed: **Dec. 29, 2014**
- (51) **LOC (11) Cl.** **09-03**
- (52) **U.S. Cl.**
USPC **D9/432**
- (58) **Field of Classification Search**
USPC D9/414-418, 420-427, 430-434;
D3/270, 272, 273; D7/601, 602
CPC B65D 5/00-5/02; B65D 5/0209-5/0272;
B65D 5/029; B65D 5/38; B65D 5/40;
B65D 5/72; B65D 5/727; B65D
31/10-31/18;

(Continued)

(56) **References Cited**

U.S. PATENT DOCUMENTS

- 625,757 A * 5/1899 Goneman B65D 5/38
206/535
- 2,231,726 A * 2/1941 Looke, Jr. B65D 5/38
206/353

(Continued)

FOREIGN PATENT DOCUMENTS

- WO WO 98/57295 12/1998
- WO WO 2009/079153 6/2009

OTHER PUBLICATIONS

“Flo,” The Band-Aidiaries, 1 p. (Apr. 27, 2011).

(Continued)

Primary Examiner — Vy N Koenig
(74) *Attorney, Agent, or Firm* — Klarquist Sparkman, LLP

(57) **CLAIM**

The ornamental design for a display box, as shown and described.

DESCRIPTION

FIG. 1 is a front perspective view of the new design for a display box. In particular, FIG. 1 shows a display box comprising an exterior sleeve with an open bottom side and an interior compartment with an open front side. The interior compartment is slidably insertable into the exterior sleeve to form a box with no open sides.

FIG. 2 is a left side view of the new design of FIG. 1. FIG. 3 is a right side view of the new design of FIG. 1. FIG. 4 is a back side view of the new design of FIG. 1. FIG. 5 is a front side view of the new design of FIG. 1. FIG. 6 is a top view of the new design of FIG. 1. FIG. 7 is a bottom view of the new design of FIG. 1. FIG. 8 is a front perspective view of the new design of FIG. 1 with the interior compartment removed from the exterior sleeve; and, FIG. 9 is a front perspective view of the new design of FIG. 1 with the interior compartment fully inserted into the exterior sleeve.

In the figures, the thinner solid lines appearing within the boundaries of the interactive insurance display box system are shading lines used to indicate the system’s surfaces. The dash-dot broken lines shown in the figures indicate the boundaries of the claimed design, while the evenly spaced broken lines of the system are directed to unclaimed subject matter. Further, the diagonal shading lines in the two thin bands along the top and bottom borders of the back surface of the exterior sleeve indicate a contrast in appearance.

1 Claim, 5 Drawing Sheets

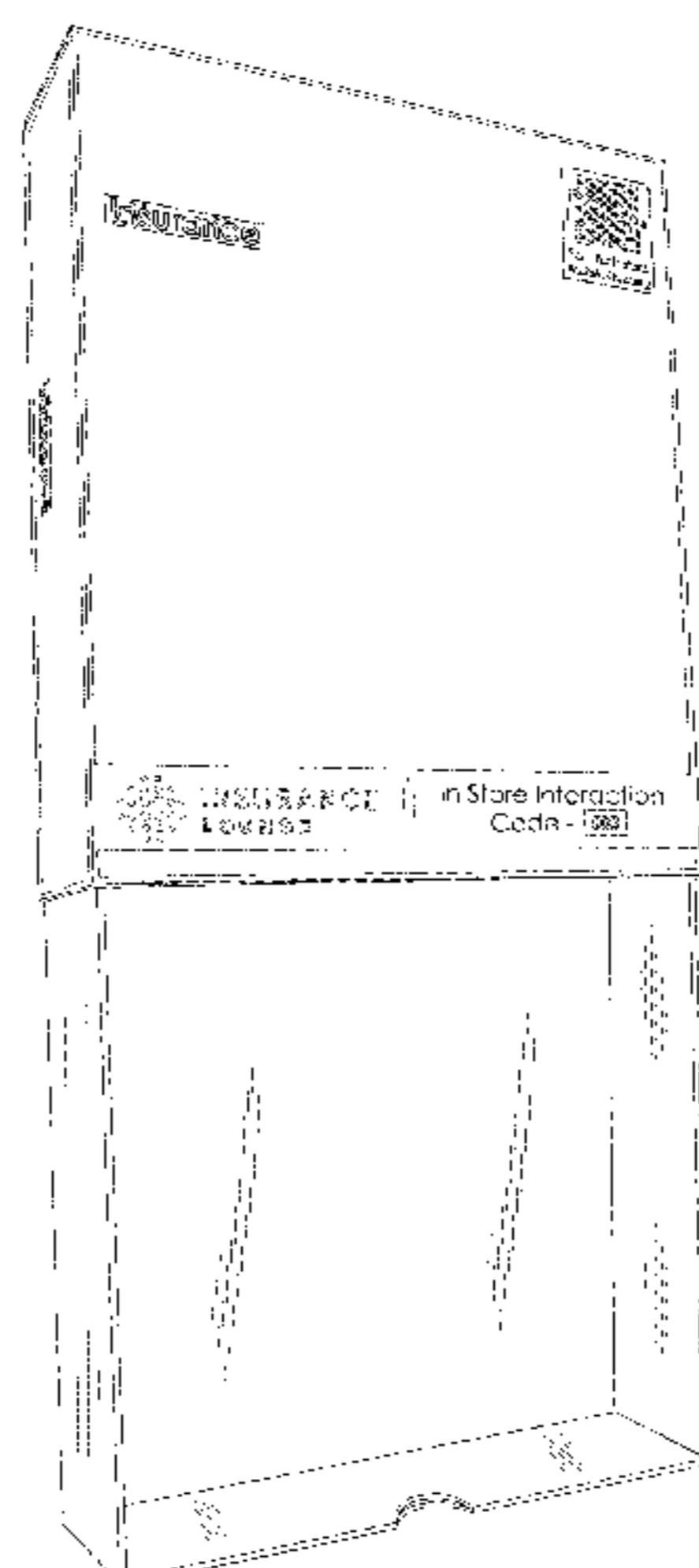

(58) **Field of Classification Search**
 CPC B65D 35/04; B65D 35/56; B65D 67/00;
 B65D 81/36; B65D 81/60; B65D 81/368
 See application file for complete search history.

(56) **References Cited**

U.S. PATENT DOCUMENTS

2,936,944	A *	5/1960	Moore	B65D 5/38
					229/125.125
3,184,050	A *	5/1965	Dahlberg	B65D 5/38
					206/229
3,395,849	A *	8/1968	Gillam	B65D 5/38
					229/125.125
4,671,449	A *	6/1987	Fronduti	B65D 5/38
					206/540
D536,245	S *	2/2007	Bruun	D9/422
7,389,875	B2 *	6/2008	Sandberg	B65D 5/38
					206/1.5
D668,145	S *	10/2012	Turner	D9/432
8,376,846	B1	2/2013	DiMichele et al.		
D747,190	S *	1/2016	DeLaGrange	D9/432
D756,237	S *	5/2016	Kruse	D9/432
2004/0099565	A1 *	5/2004	Dehlin	B65D 50/046
					206/536

2007/0181458	A1 *	8/2007	Ehrlund	B65D 5/38
					206/528
2008/0289977	A1 *	11/2008	Ghini	B65D 5/38
					206/256
2010/0032975	A1	2/2010	Cohen et al.		
2010/0161434	A1	6/2010	Herwig et al.		
2010/0236957	A1 *	9/2010	Dehlin	B65D 5/38
					206/438
2011/0089799	A1	4/2011	Goretti		
2012/0022898	A1	1/2012	Koa		

OTHER PUBLICATIONS

“Go with our Flo,” Seen and noted—Best ads: TV, Print, Outdoor, Interactive, Radio, 16 pp. (Mar. 5, 2009).
 Reiter, “QR Codes Hit Healthcare,” downloaded from <http://www.mobilehealthcaretoday.com/>, 1 p. (Mar. 15, 2011).
 Screenshots from video located at: <http://www.youtube.com/watch?v=4ZJMPFIyk2Q>, 2 pp. (video marked as uploaded on Sep. 1, 2009).
 “The price gun goes only so low,” Consumer Reports, 1 p. (Nov. 2009).

* cited by examiner

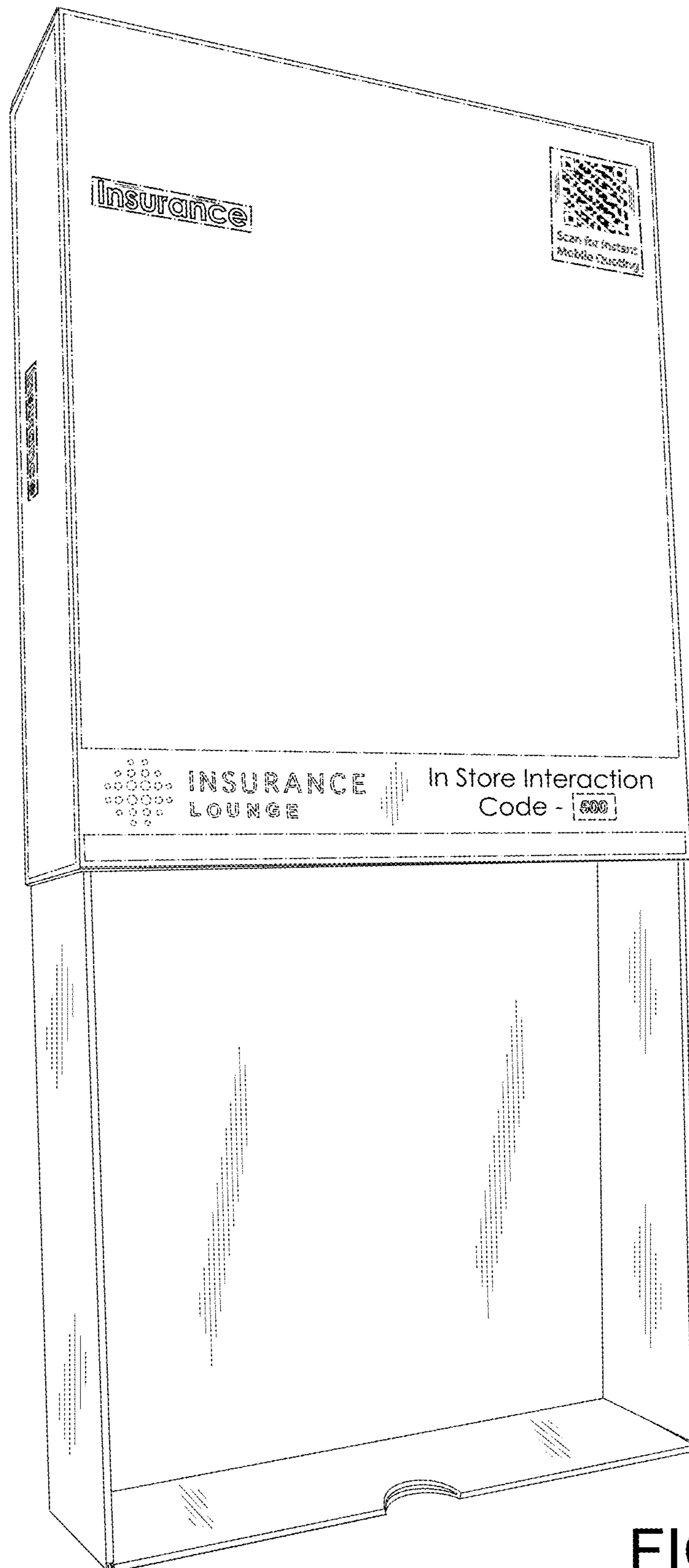

FIG. 1

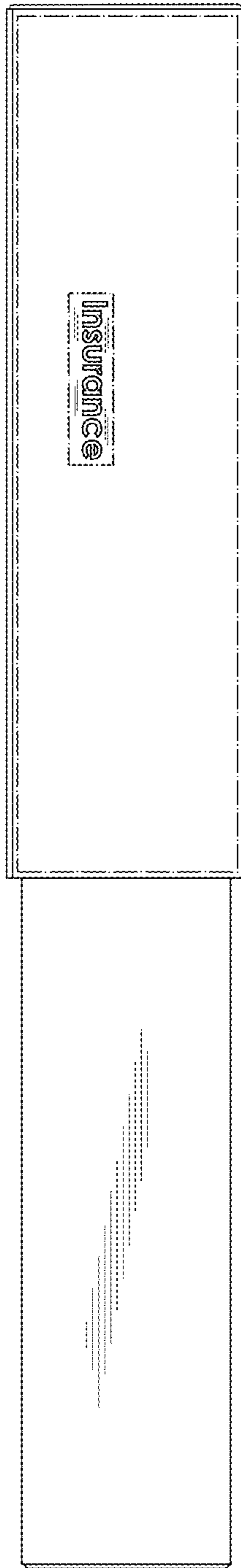

FIG. 2

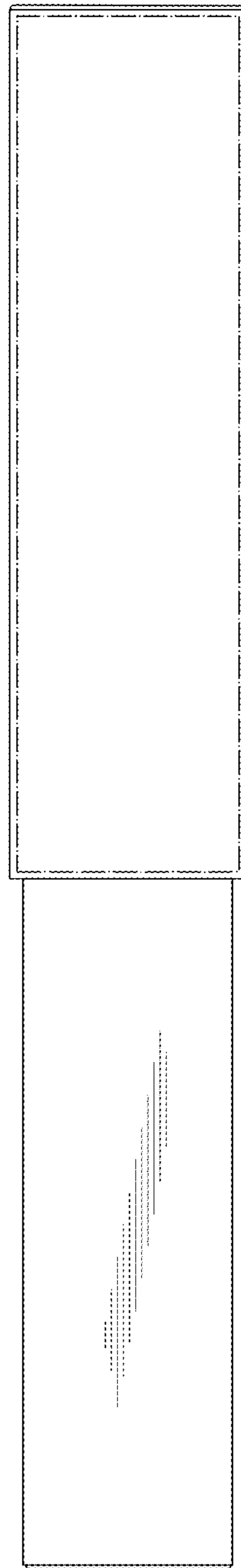

FIG. 3

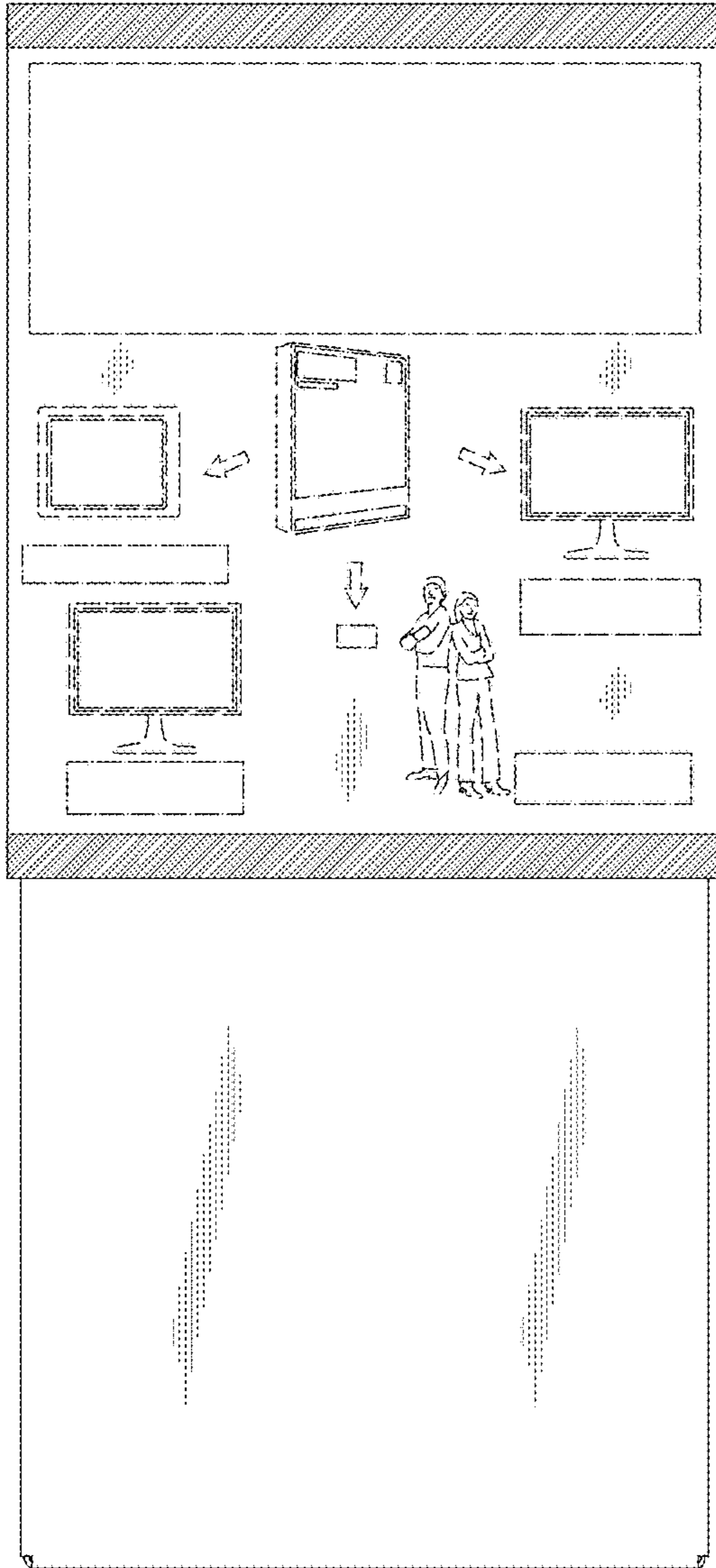

FIG. 4

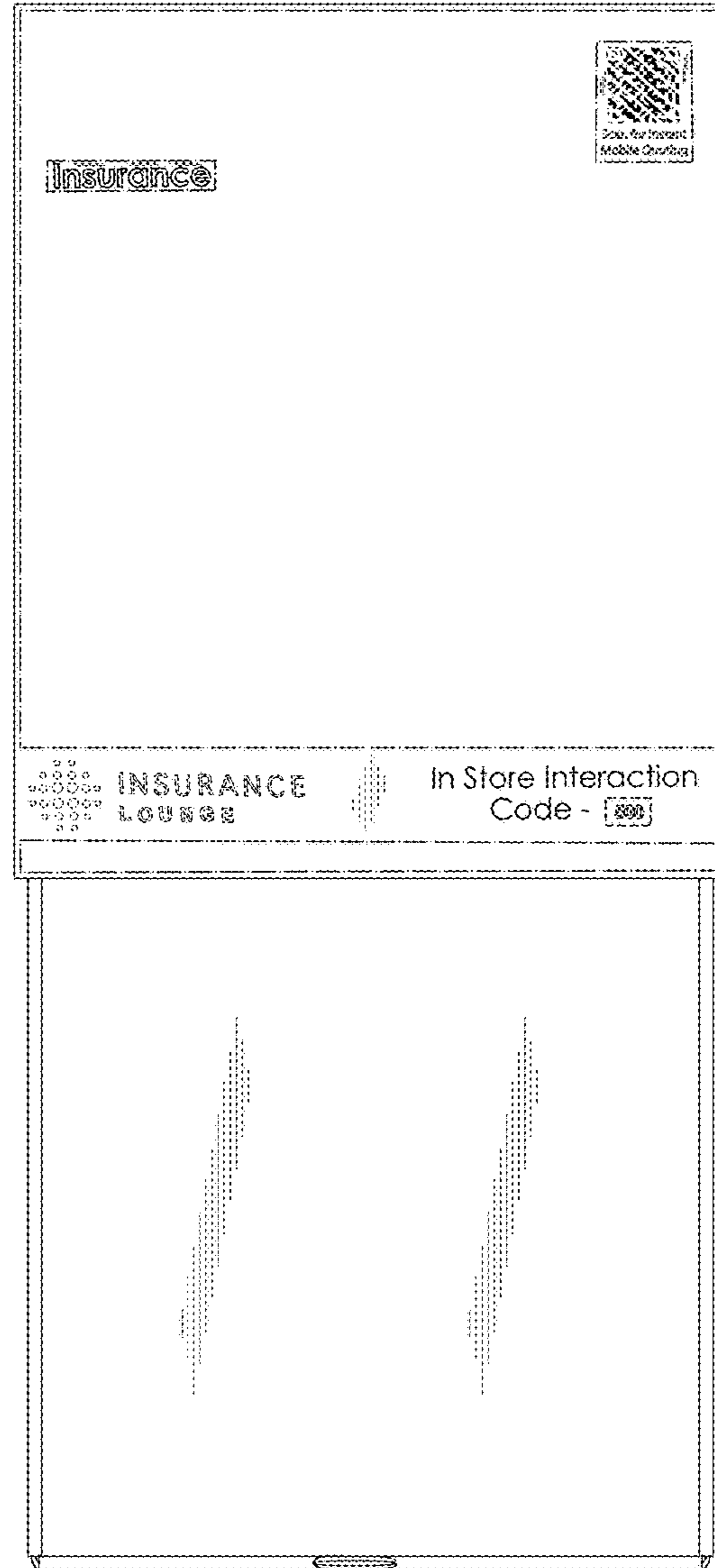

FIG. 5

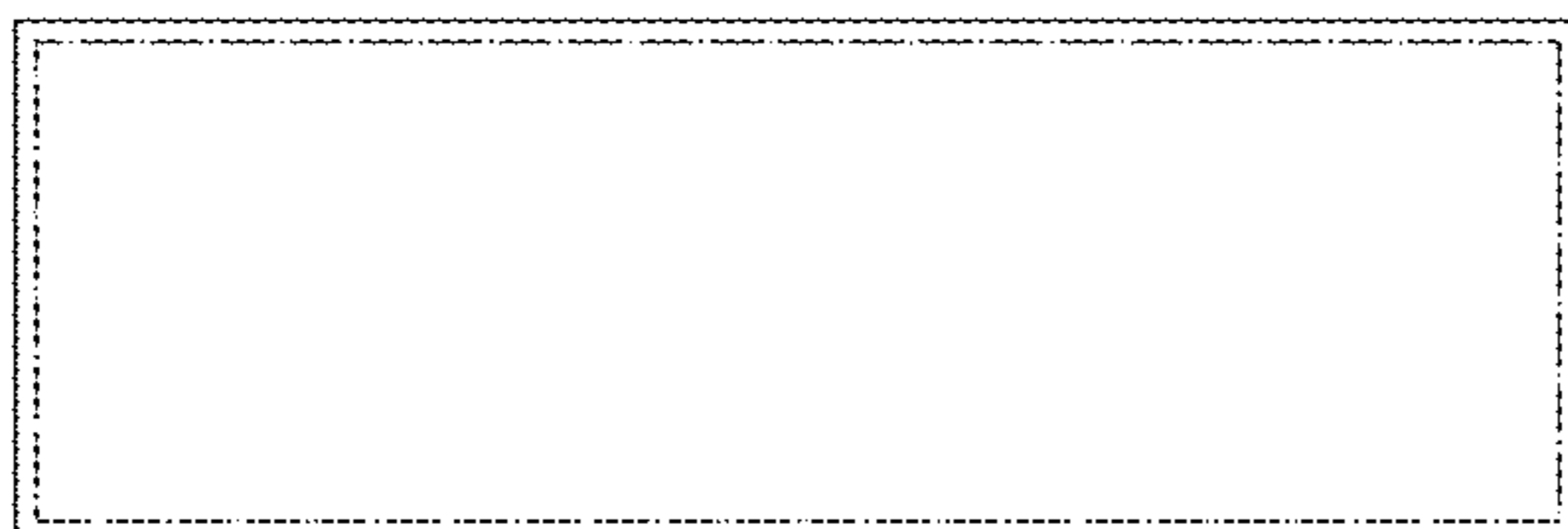

FIG. 6

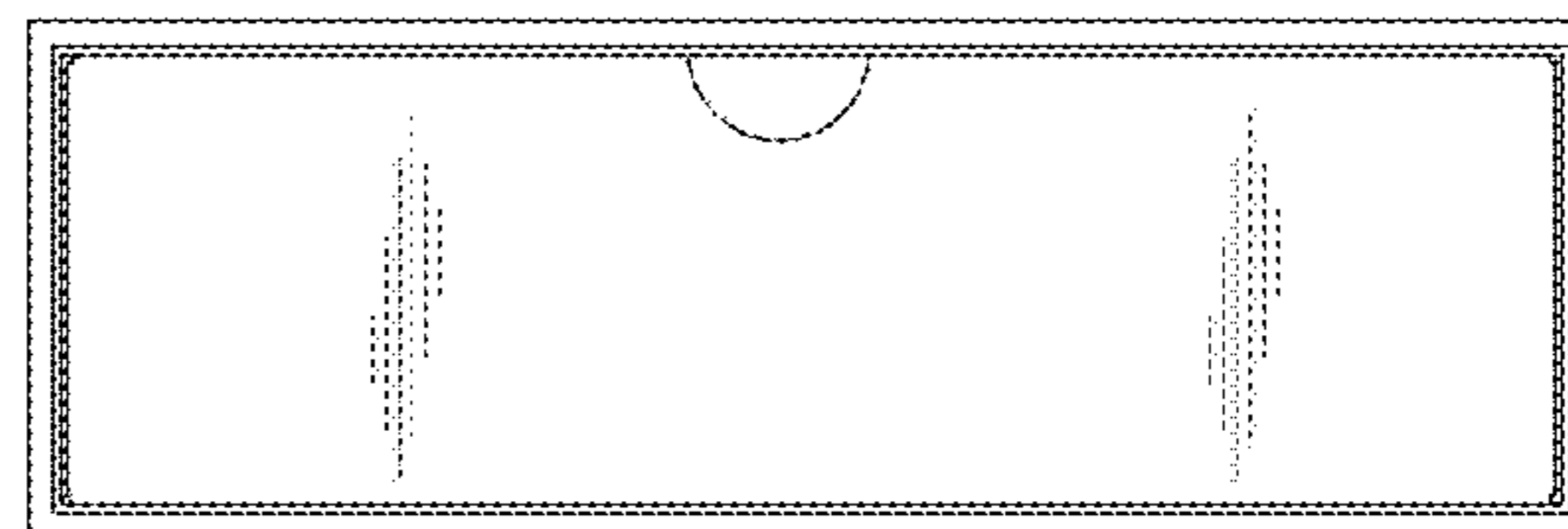

FIG. 7

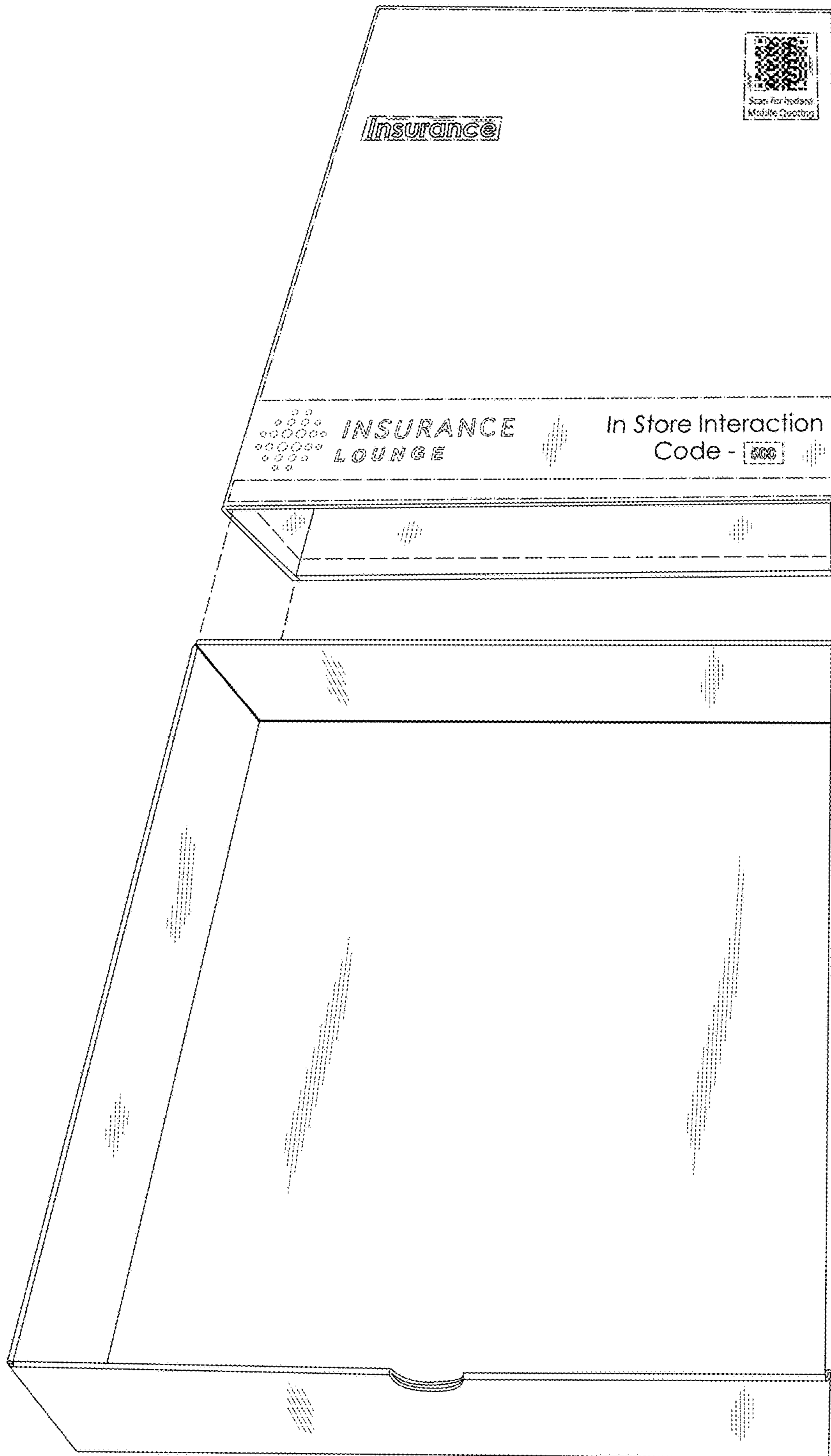

FIG. 8



FIG. 9