



US00D808000S

(12) **United States Design Patent** (10) **Patent No.:** **US D808,000 S**
McMahon (45) **Date of Patent:** **** Jan. 16, 2018**

(54) **EXHAUST FAN RECAPTURE GENERATOR**
(71) Applicant: **Primo Wind, Inc.**, San Diego, CA (US)
(72) Inventor: **Edward McMahon**, San Diego, CA (US)

4,868,408 A 9/1989 Hesh
4,890,976 A 1/1990 Jansson
5,280,827 A 1/1994 Taylor et al.
5,368,258 A 11/1994 Johnson et al.
5,375,968 A 12/1994 Kollitz et al.
(Continued)

(73) Assignee: **Primo Wind, Inc.**, San Diego, CA (US)
(**) Term: **15 Years**

FOREIGN PATENT DOCUMENTS

CN 203560041 4/2014
WO 2006007696 1/2006
WO 2011035415 3/2011

(21) Appl. No.: **29/542,773**

(22) Filed: **Oct. 16, 2015**

OTHER PUBLICATIONS

(51) **LOC (11) Cl.** **23-04**
(52) **U.S. Cl.**
USPC **D23/371**
(58) **Field of Classification Search**
USPC D23/370, 355, 314, 414; 415/121.1
CPC ... E03C 1/12; F24F 13/06; F24F 13/22; F24F
13/20; F24F 12/00; B01D 39/12; E03B
11/08

Tong, C.W. et al., Exhaust Air and Wind Energy Recovery System for Clean Energy Generation, 2011 International Conference on Environment and Industrial Innovation, 2011, pp. 45-49, vol. 12, IACSIT Press, Singapore.

(Continued)

See application file for complete search history.

Primary Examiner — Cynthia Underwood
(74) *Attorney, Agent, or Firm* — Perkins Coie LLP

(56) **References Cited**

(57) **CLAIM**

U.S. PATENT DOCUMENTS

The ornamental design for an exhaust fan recapture generator, as shown and described.

- 3,339,078 A 8/1967 Crompton
- 3,740,565 A 6/1973 Wesley
- 3,883,750 A 5/1975 Uzzell, Jr.
- 4,012,163 A 3/1977 Baumgartner et al.
- 4,088,419 A 5/1978 Hope et al.
- 4,134,469 A 1/1979 Davis
- 4,140,433 A 2/1979 Eckel
- 4,163,904 A 8/1979 Skendrovic
- 4,218,175 A 8/1980 Carpenter
- 4,254,843 A 3/1981 Han et al.
- 4,411,588 A 10/1983 Currah, Jr.
- 4,415,306 A 11/1983 Cobden
- 4,424,452 A 1/1984 Francis
- 4,524,285 A 6/1985 Rauch
- 4,600,360 A 7/1986 Quarterman
- 4,781,522 A 11/1988 Wolfrun

DESCRIPTION

FIG. 1 is a front perspective view of an exhaust fan recapture generator.
The side perspective and back perspective views of the exhaust fan recapture generator appear the same as FIG. 1.
FIG. 2 is a top view of the exhaust fan recapture generator; and,
FIG. 3 is a bottom view of the exhaust fan recapture generator.
The broken lines represent portions of the structure that form no part of the claim.

1 Claim, 3 Drawing Sheets

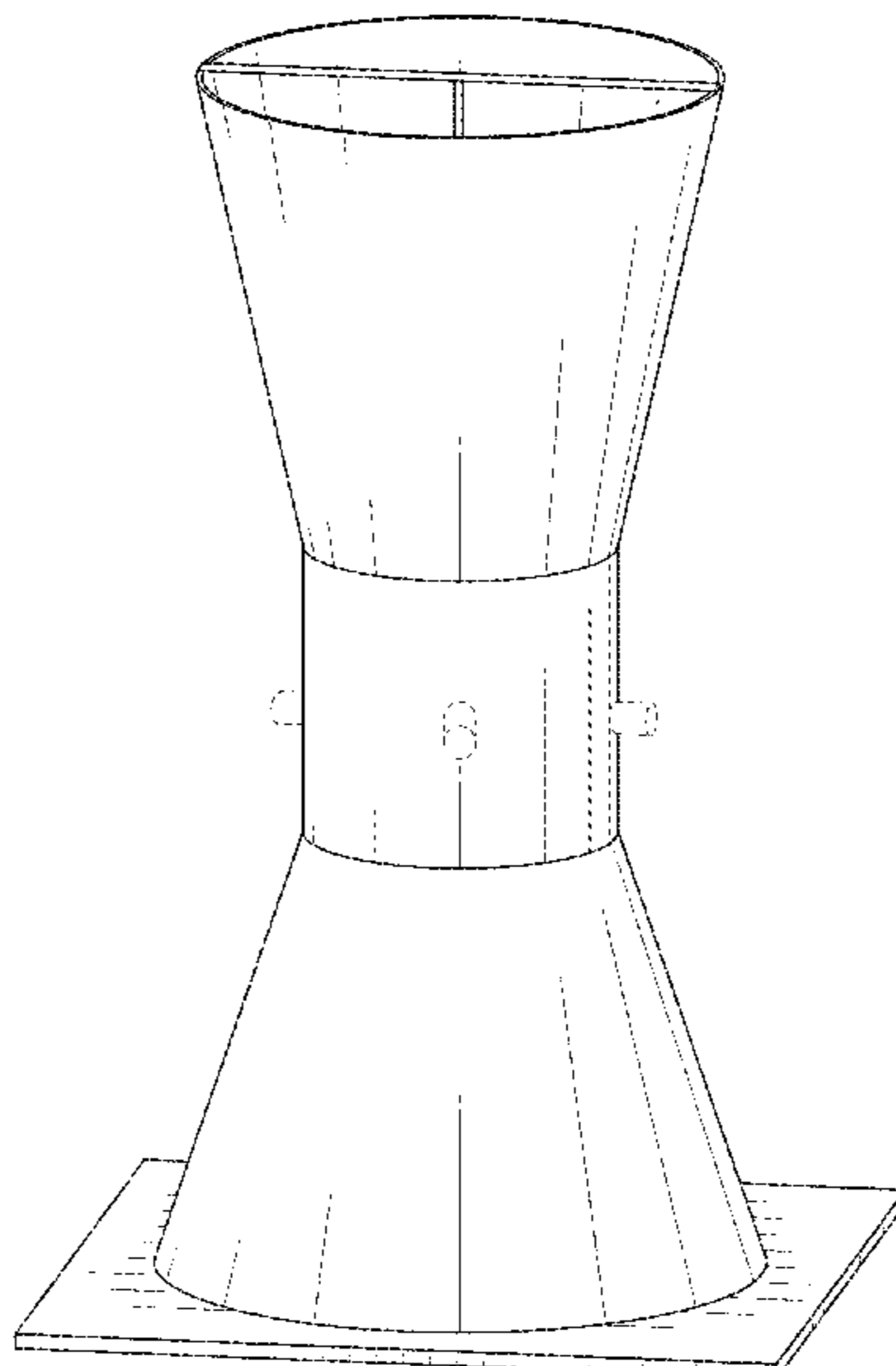

(56)

References Cited

U.S. PATENT DOCUMENTS

5,381,048 A 1/1995 Baird
 5,512,788 A 4/1996 Berenda et al.
 5,799,680 A 9/1998 Dorflinger
 6,132,181 A 10/2000 McCabe
 6,365,985 B1 4/2002 Cohen
 6,448,669 B1 9/2002 Elder
 7,112,034 B2 9/2006 Bezemer
 7,276,809 B2 10/2007 Zambrano et al.
 D558,669 S 1/2008 Jeanvigite
 7,315,093 B2 1/2008 Graham, Sr.
 7,354,245 B2 4/2008 Baba
 7,380,751 B1 6/2008 Henson
 7,994,652 B2 8/2011 Grabau et al.
 D659,257 S * 5/2012 Desberg D24/232
 8,183,709 B1 5/2012 Manning
 8,253,267 B2 8/2012 Gilbert
 D670,985 S * 11/2012 Tompkin D26/49
 8,338,974 B2 12/2012 Nyffenegger
 D699,336 S * 2/2014 Girard D23/370
 8,664,781 B2 3/2014 Alvi
 8,952,557 B2 2/2015 Farrell
 8,963,359 B2 2/2015 Evans et al.
 9,041,238 B2 5/2015 McMahan
 9,151,512 B2 * 10/2015 Lipinski F24F 7/02
 2002/0040555 A1 4/2002 Banks et al.
 2004/0061337 A1 4/2004 Becker
 2005/0006904 A1 1/2005 Bayer
 2005/0242590 A1 11/2005 Zambrano et al.

2006/0108809 A1 5/2006 Sealzi
 2007/0018462 A1 1/2007 Richards et al.
 2008/0093861 A1 4/2008 Friesth et al.
 2008/0303287 A1 12/2008 Meheen
 2009/0066090 A1 3/2009 Boone
 2009/0095867 A1 4/2009 Oh et al.
 2009/0191057 A1 7/2009 Knutson
 2010/0090605 A1 4/2010 Nevins
 2010/0126086 A1 5/2010 Paggi
 2010/0207389 A1 8/2010 Nyffenegger
 2010/0244455 A1 9/2010 Berginc
 2011/0031043 A1 2/2011 Armani et al.
 2011/0293419 A1 12/2011 Koya et al.
 2011/0309723 A1 12/2011 Lu et al.
 2012/0043761 A1 2/2012 White
 2012/0175882 A1 7/2012 Sterling et al.
 2012/0280503 A1 11/2012 Mahawili
 2014/0092613 A1 4/2014 Maeda et al.
 2017/0108238 A1 * 4/2017 McMahan F24F 12/00

OTHER PUBLICATIONS

Chapter 3 Rotational Flows: Circulation and Turbulence, available at https://web.archive.org/web/20150922030158/http://maxwell.ucdavis.edu/~cole/phy9b/notes/fluids_ch3.pdf.
 Singh, T., SheerWind's INVELOX Wind Turbine Can Generate 600% More Energy Than Conventional Turbines, Inhabitat, available at <http://inhabitat.com/sheerwinds-invelox-wind-turbine-can-generate-600-more-energy-than-conventional-turbines/>.

* cited by examiner

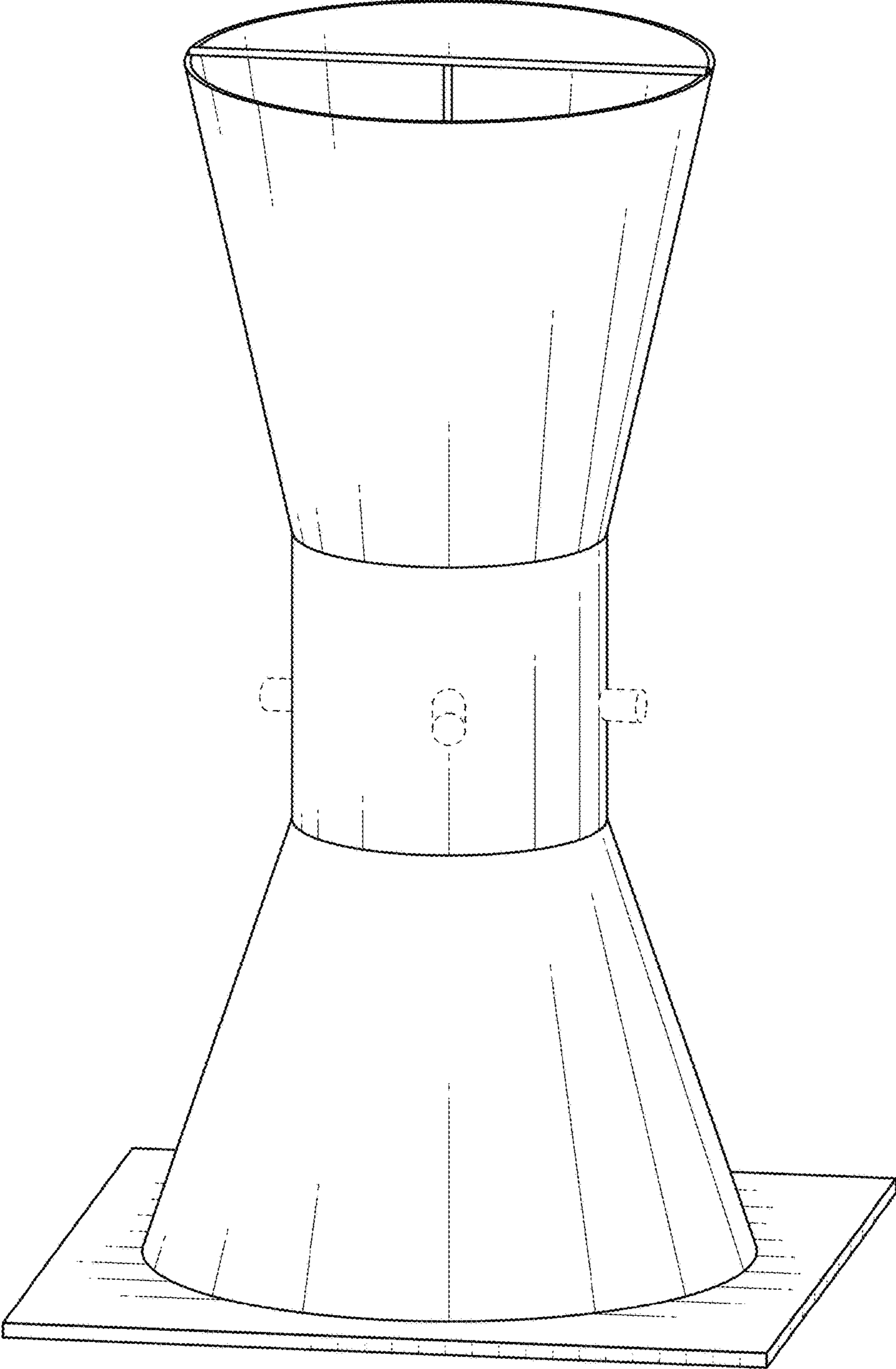

FIG. 1

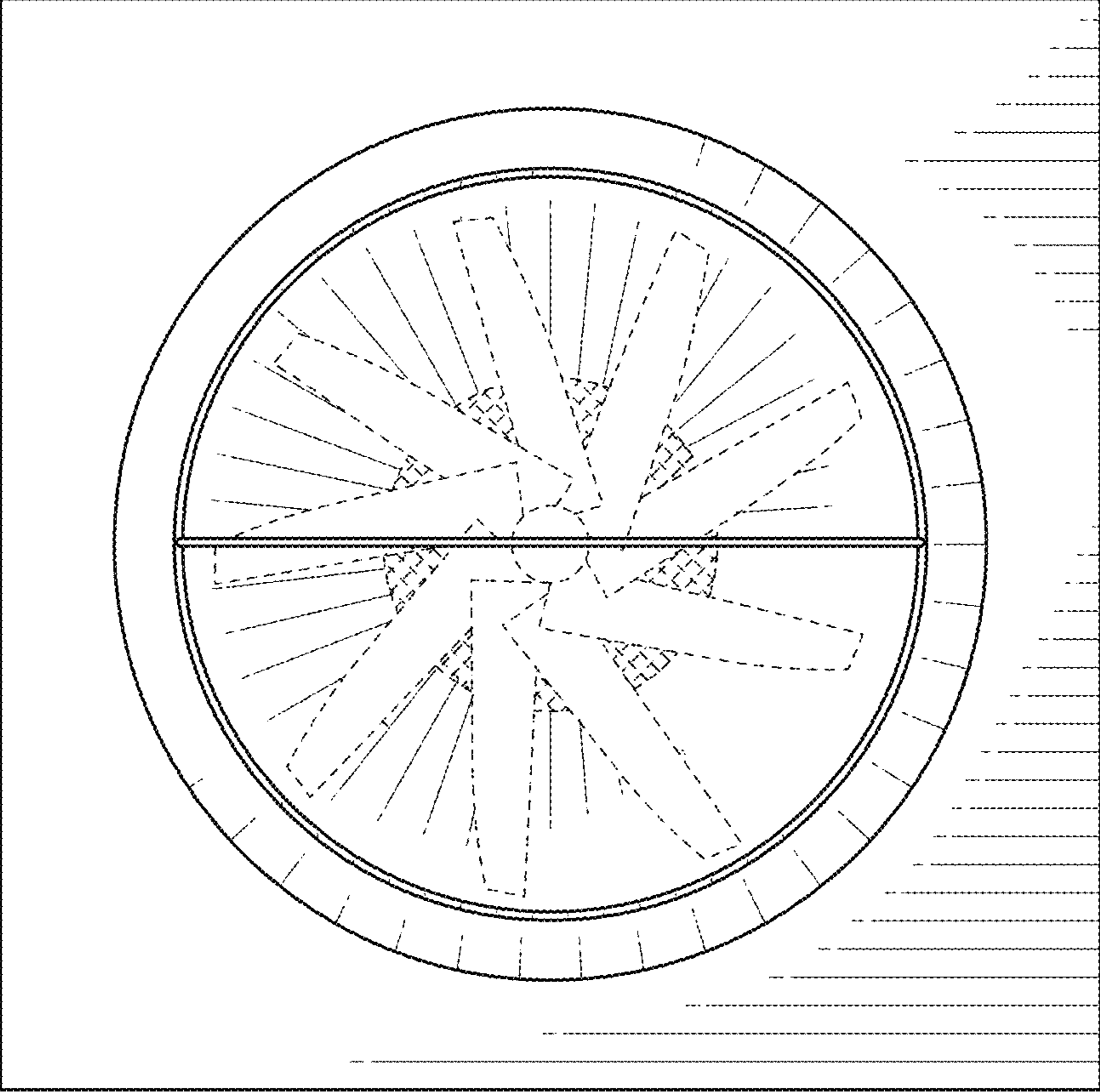

FIG. 2

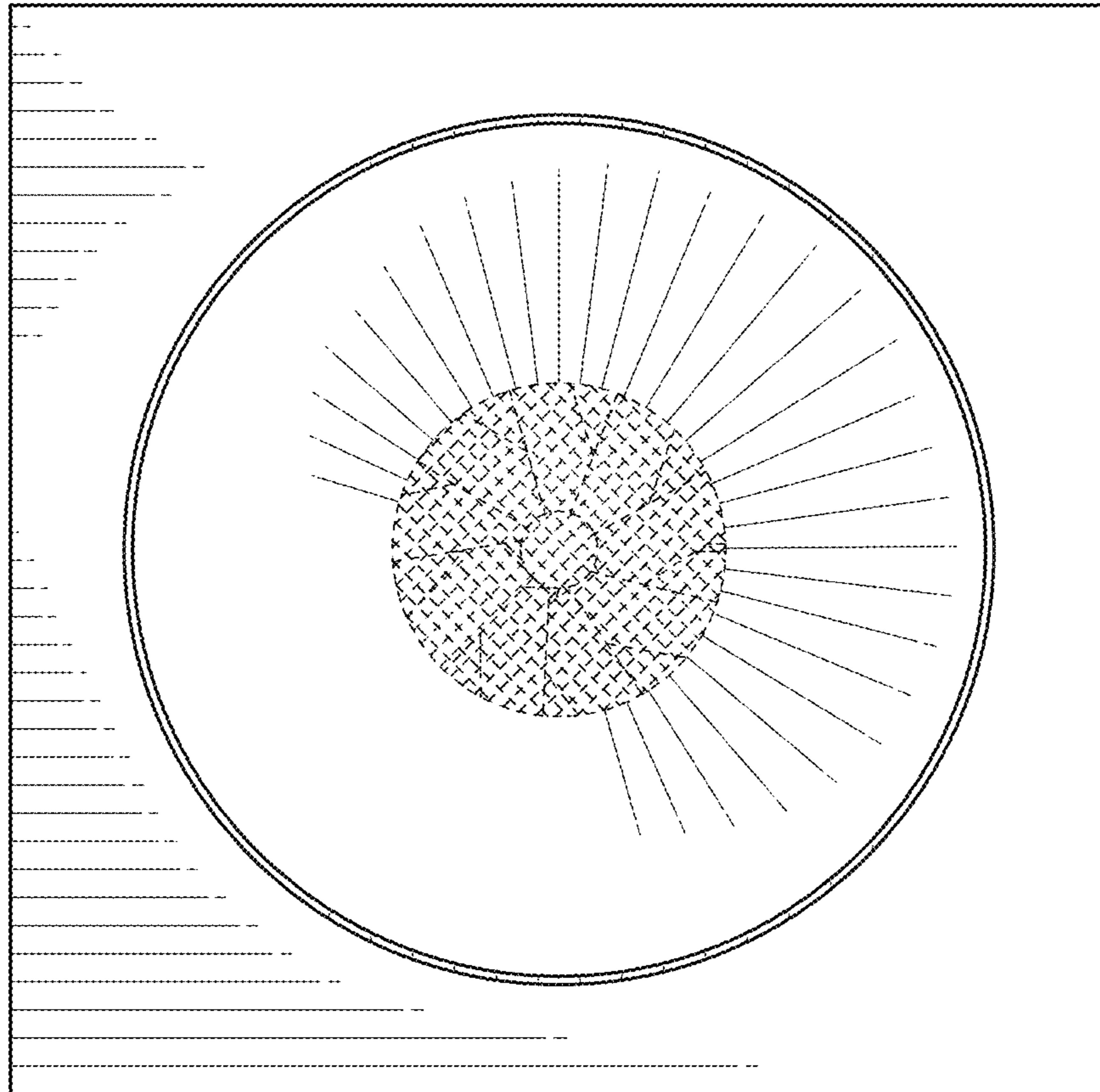

FIG. 3