



US00D807984S

(12) **United States Design Patent**
Borovicka et al.

(10) **Patent No.:** **US D807,984 S**
(45) **Date of Patent:** **** Jan. 16, 2018**

- (54) **HANDHELD BUG ZAPPER**
- (71) Applicant: **Charcoal Companion Incorporated**,
Berkeley, CA (US)
- (72) Inventors: **Cory Thomas Borovicka**, Oakland, CA
(US); **Bennett Gershkow**, San
Francisco, CA (US)
- (73) Assignee: **Charcoal Companion Incorporated**,
Berkeley, CA (US)
- (**) Term: **15 Years**
- (21) Appl. No.: **29/586,434**
- (22) Filed: **Dec. 2, 2016**
- (51) **LOC (11) Cl.** **22-06**
- (52) **U.S. Cl.**
USPC **D22/124**
- (58) **Field of Classification Search**
USPC D22/119-124; 43/112, 137
CPC . A01M 3/025; A01M 1/223; A01M 2200/012
See application file for complete search history.

D540,415 S * 4/2007 Zemel D22/124
 8,181,385 B2 5/2012 Mars
 D675,283 S 1/2013 Dooley et al.
 2007/0271839 A1 11/2007 Su

OTHER PUBLICATIONS

Amazon.com; Bug Zapper by Zap-it!; URL: <http://a.co/eZo31X4>;
 Date Retrieved: Feb. 27, 2017.
 Amazon.com; Amazing Handheld Electric Bug Zapper by Charcoal
 Companion; URL: <http://a.co/8CG0xiM>; Date Retrieved: Feb. 27,
 2017.
 Amazon.com; Stinger Bug Zapper Racket by Kaz; URL: <http://a.co/8keexM7>;
 Date Retrieved: Feb. 27, 2017.

* cited by examiner

Primary Examiner — Catherine R Oliver-Garcia
 (74) *Attorney, Agent, or Firm* — Beeson Skinner Beverly,
 LLP

(57) **CLAIM**

The ornamental design for a handheld bug zapper, as shown
and described.

DESCRIPTION

FIG. 1 is a bottom front perspective view of a handheld bug
 zapper showing our new design;
 FIG. 2 is a front elevation view thereof;
 FIG. 3 is a left side elevation view thereof;
 FIG. 4 is a rear elevation view thereof;
 FIG. 5 is a right side elevation view thereof;
 FIG. 6 is a top plan view thereof; and,
 FIG. 7 is a bottom plan view thereof.

1 Claim, 4 Drawing Sheets

- (56) **References Cited**
- U.S. PATENT DOCUMENTS
- 2,881,554 A * 4/1959 Laine A01M 1/223
43/112
- 5,519,963 A * 5/1996 Shih A01M 1/223
43/112
- 5,533,298 A * 7/1996 Teng A01M 1/223
43/112
- 6,105,306 A * 8/2000 Teng A01M 1/223
43/112
- D516,159 S * 2/2006 Himberger D22/124

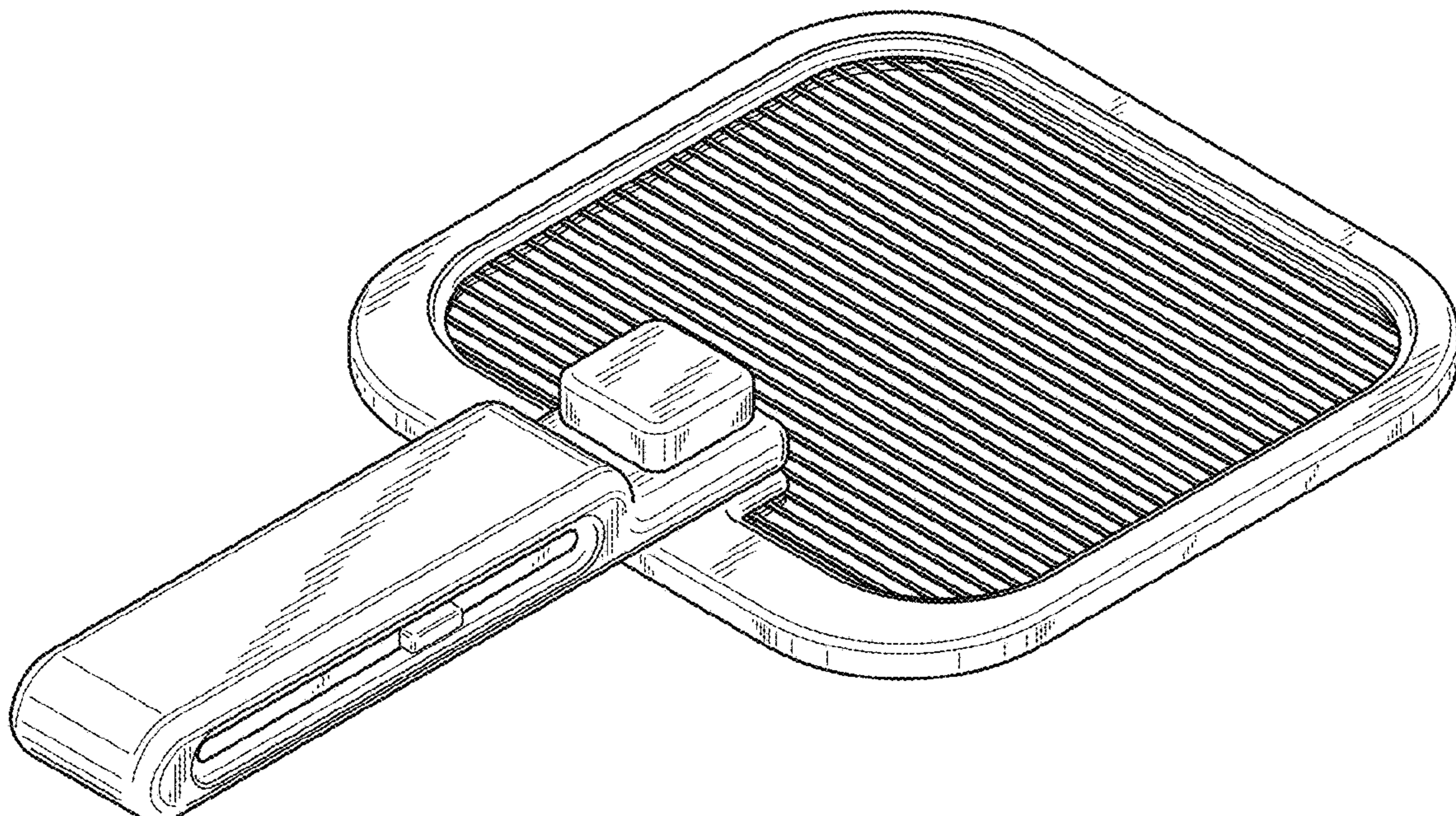

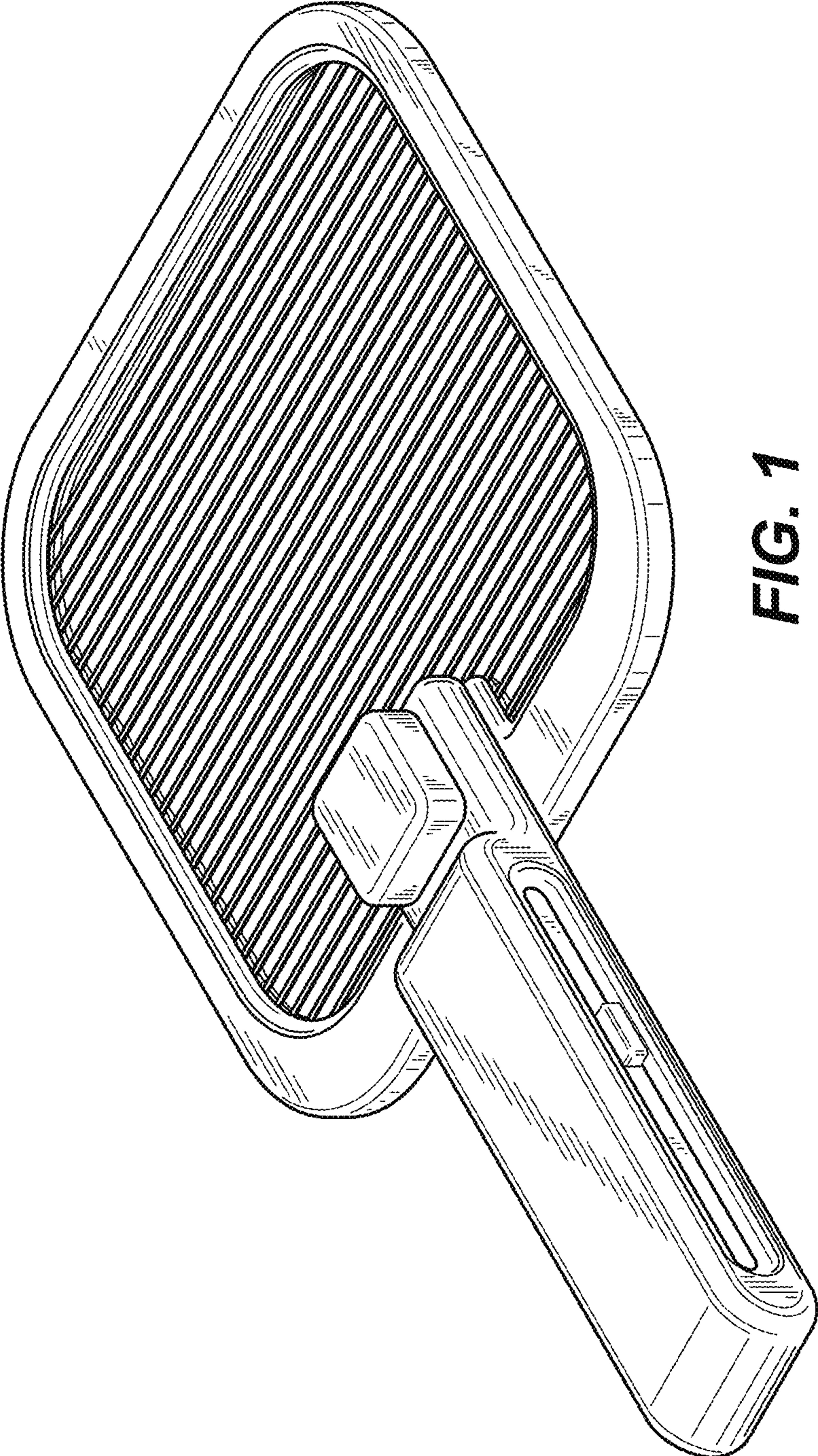

FIG. 1

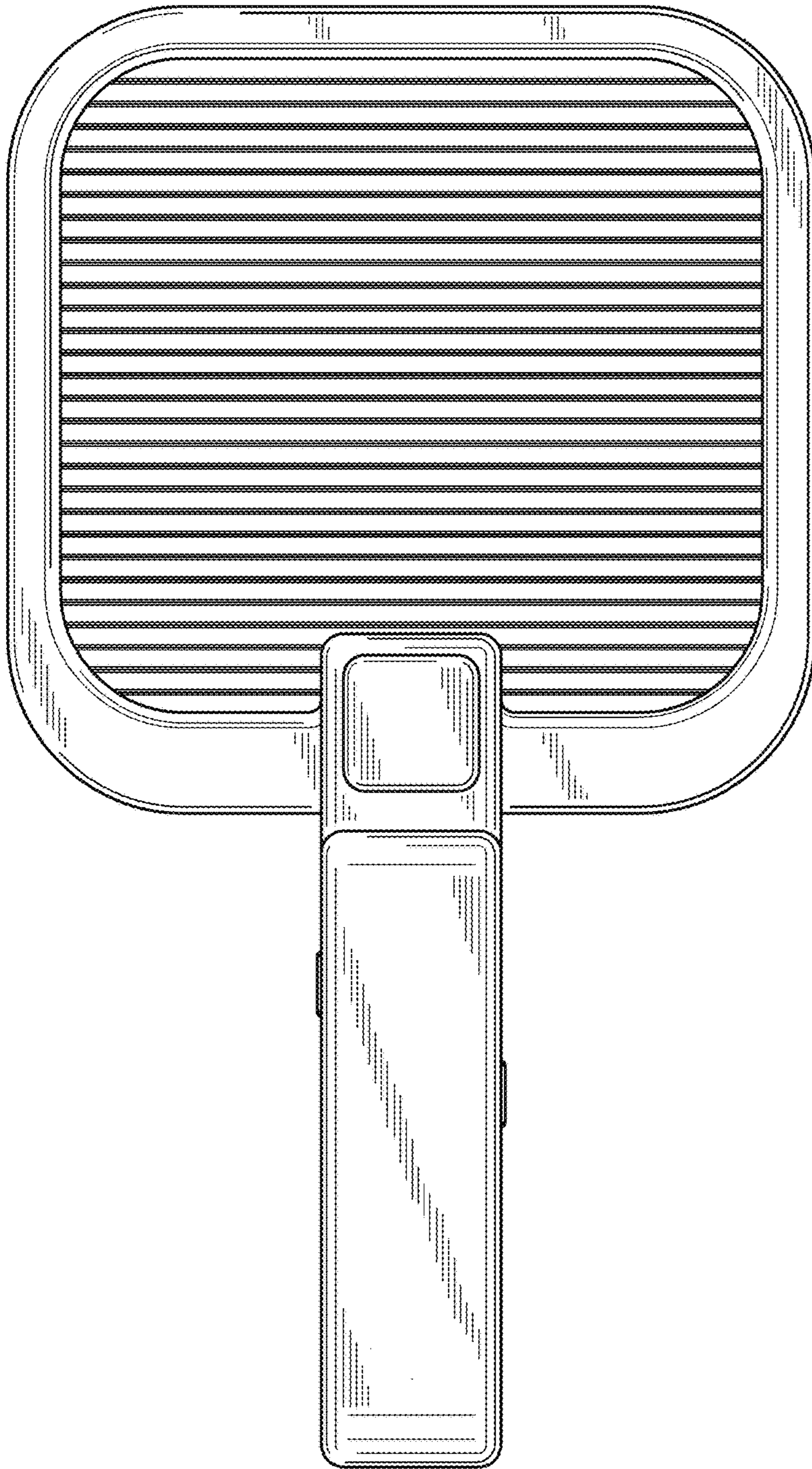

FIG. 2

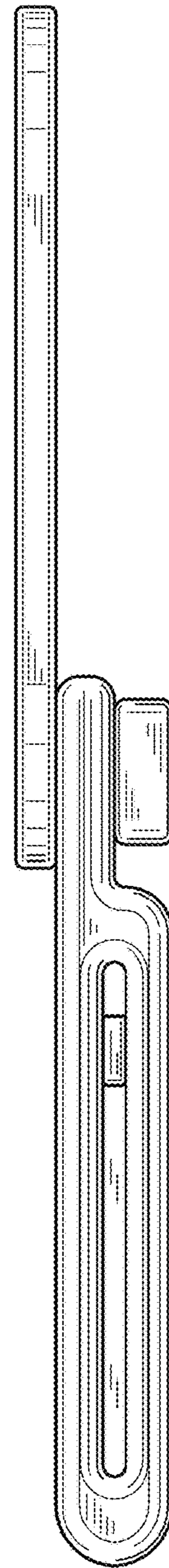

FIG. 3

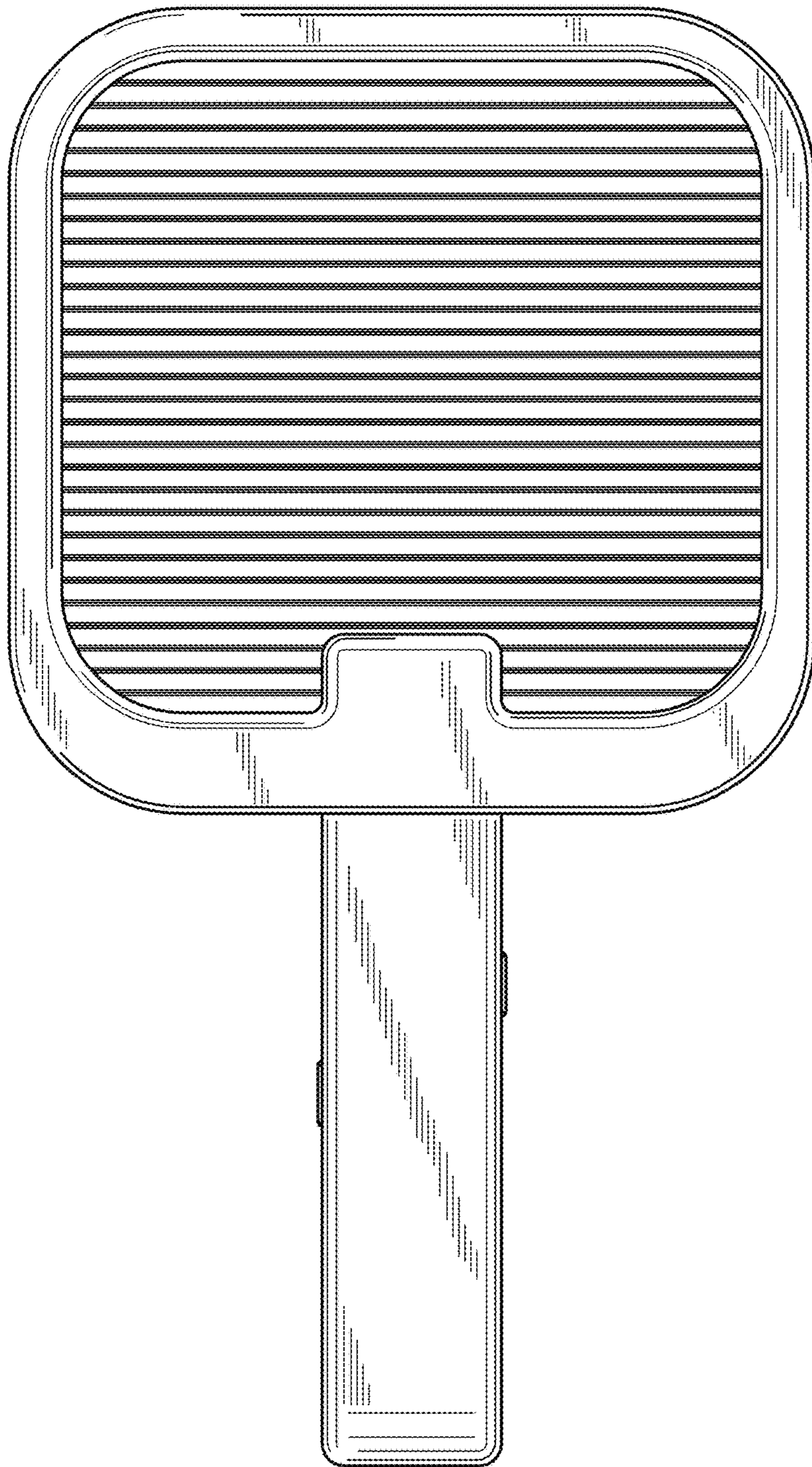

FIG. 4

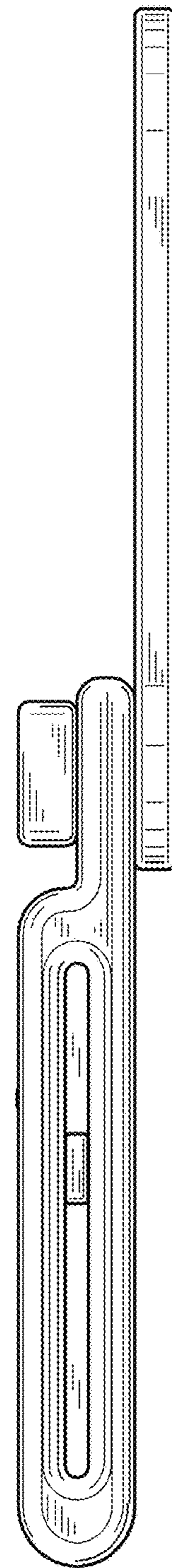

FIG. 5

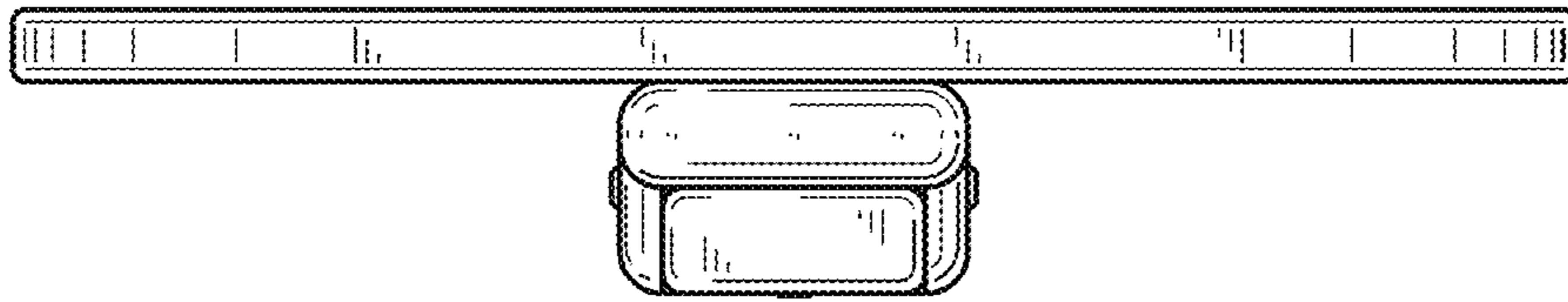

FIG. 6

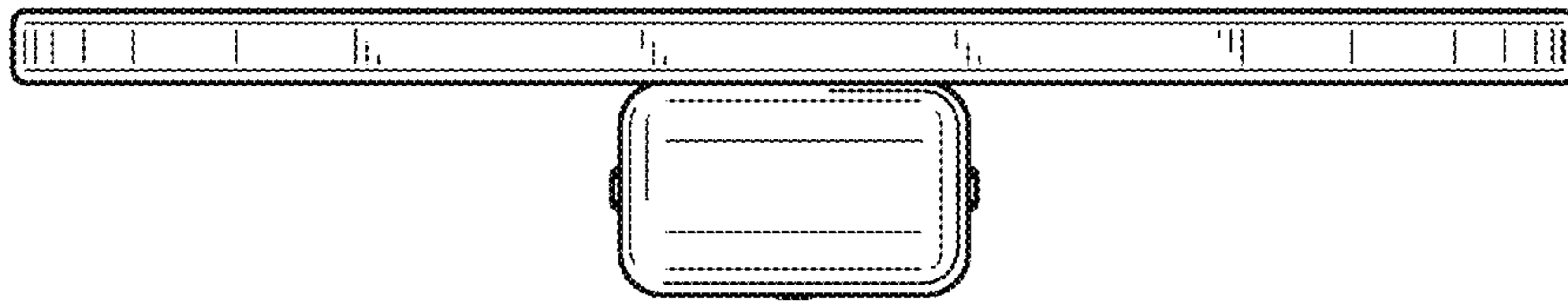

FIG. 7