

US00D807944S

(12) **United States Design Patent**
Worthington et al.

(10) **Patent No.:** **US D807,944 S**

(45) **Date of Patent:** **** Jan. 16, 2018**

(54) **INTERACTIVE DIGITAL EDITING AND STREAMING CAMERA**

(71) Applicant: **Livestream LLC**, Brooklyn, NY (US)

(72) Inventors: **Philip Tomasz Worthington**, New York, NY (US); **Jimmy S. An**, Hillsborough, NJ (US); **Shi Gang Yuan**, Brooklyn, NY (US); **Sergii Maliuk**, Zaporizhia (UA); **Jesse H. Hertzberg**, New York, NY (US); **Maxime G. G. Haot**, New York, NY (US)

(73) Assignee: **LIVESTREAM LLC**, Brooklyn, NY (US)

(**) Term: **15 Years**

(21) Appl. No.: **29/547,589**

(22) Filed: **Dec. 4, 2015**

(51) **LOC (11) Cl.** **16-01**

(52) **U.S. Cl.**
USPC **D16/218**

(58) **Field of Classification Search**
USPC D14/172, 204, 210, 215, 216, 221;
D16/200–205, 208, 218–219; 348/148,
348/373–376; 396/529, 535–541
CPC G03B 15/03; G03B 17/02; G03B 17/04;
G03B 17/56; G03B 19/04; H04N 5/2251;
H04N 5/2252; H04N 5/2253; H04N
5/2254; H04N 2101/00
See application file for complete search history.

(56) **References Cited**

U.S. PATENT DOCUMENTS

D454,902 S * 3/2002 Hsu D16/202
6,705,774 B2 * 3/2004 Tashiro G08B 13/19619
348/143

D501,494 S * 2/2005 Ogura D16/202
D518,080 S * 3/2006 Uehara D16/202
D532,809 S * 11/2006 Shih D16/202
D554,168 S * 10/2007 Shi D16/202
D561,798 S * 2/2008 Wen D16/202
D590,863 S * 4/2009 Ke D16/202
D592,231 S * 5/2009 Schnell D16/202
D676,477 S * 2/2013 Chen D16/202
D728,655 S * 5/2015 Daniel D16/203
D761,340 S * 7/2016 Pacurariu D16/202
D778,973 S * 2/2017 Lee D16/202

* cited by examiner

Primary Examiner — Philip S Hyder

Assistant Examiner — Ramzi Almatrahi

(74) *Attorney, Agent, or Firm* — Lowenstein Sandler LLP

(57) **CLAIM**

The ornamental design for an interactive digital editing and streaming camera, as shown and described.

DESCRIPTION

FIG. 1 is a perspective view of an interactive digital editing and streaming camera showing our new design.

FIG. 2 is front view thereof.

FIG. 3 is rear view thereof.

FIG. 4 is a side view thereof.

FIG. 5 is an opposite side view thereof.

FIG. 6 is a top view thereof; and,

FIG. 7 is a bottom view thereof.

The broken lines depict portions of the interactive digital editing and streaming camera in which the design is embodied that form no part of the claimed design.

1 Claim, 6 Drawing Sheets

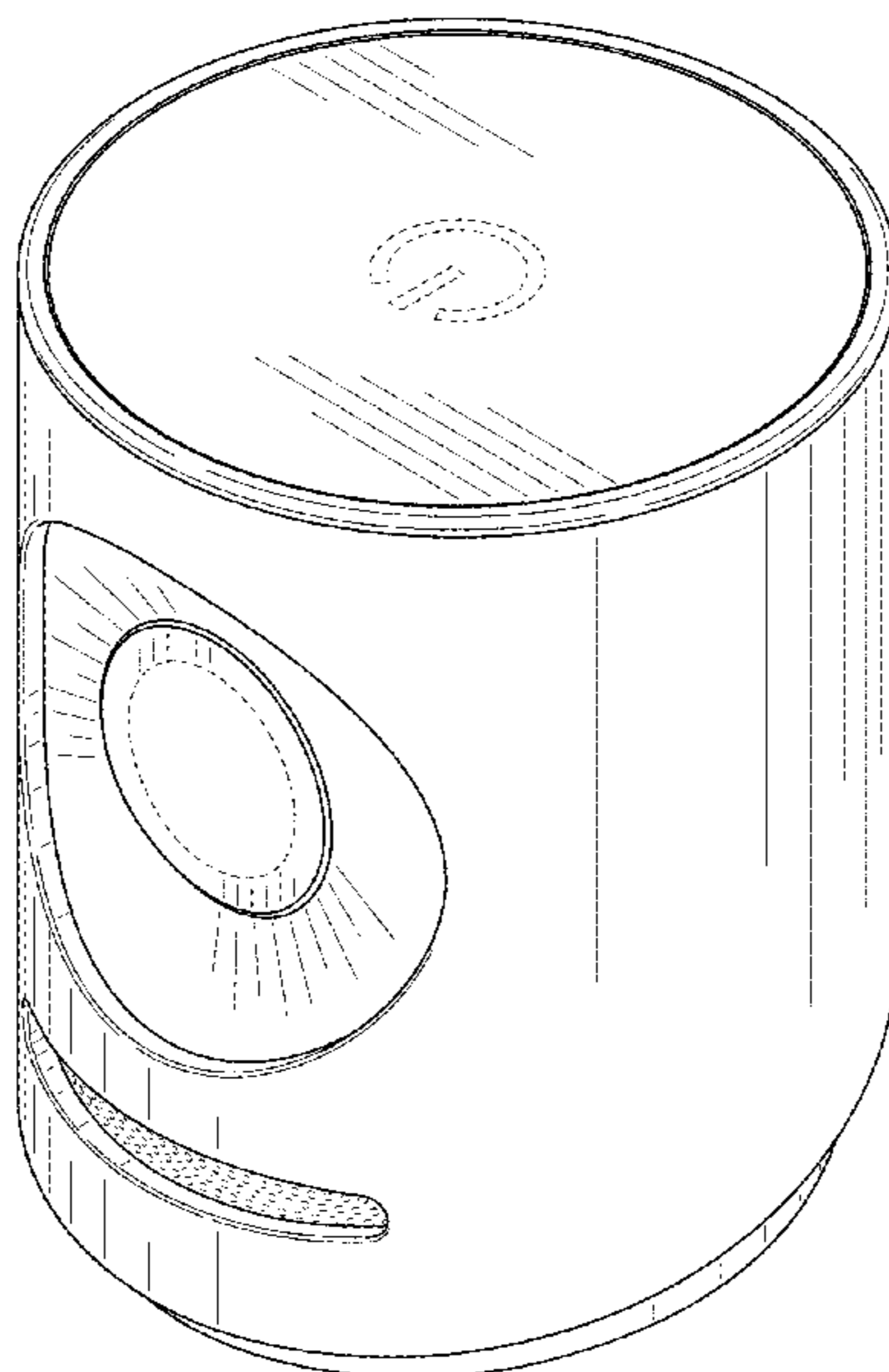

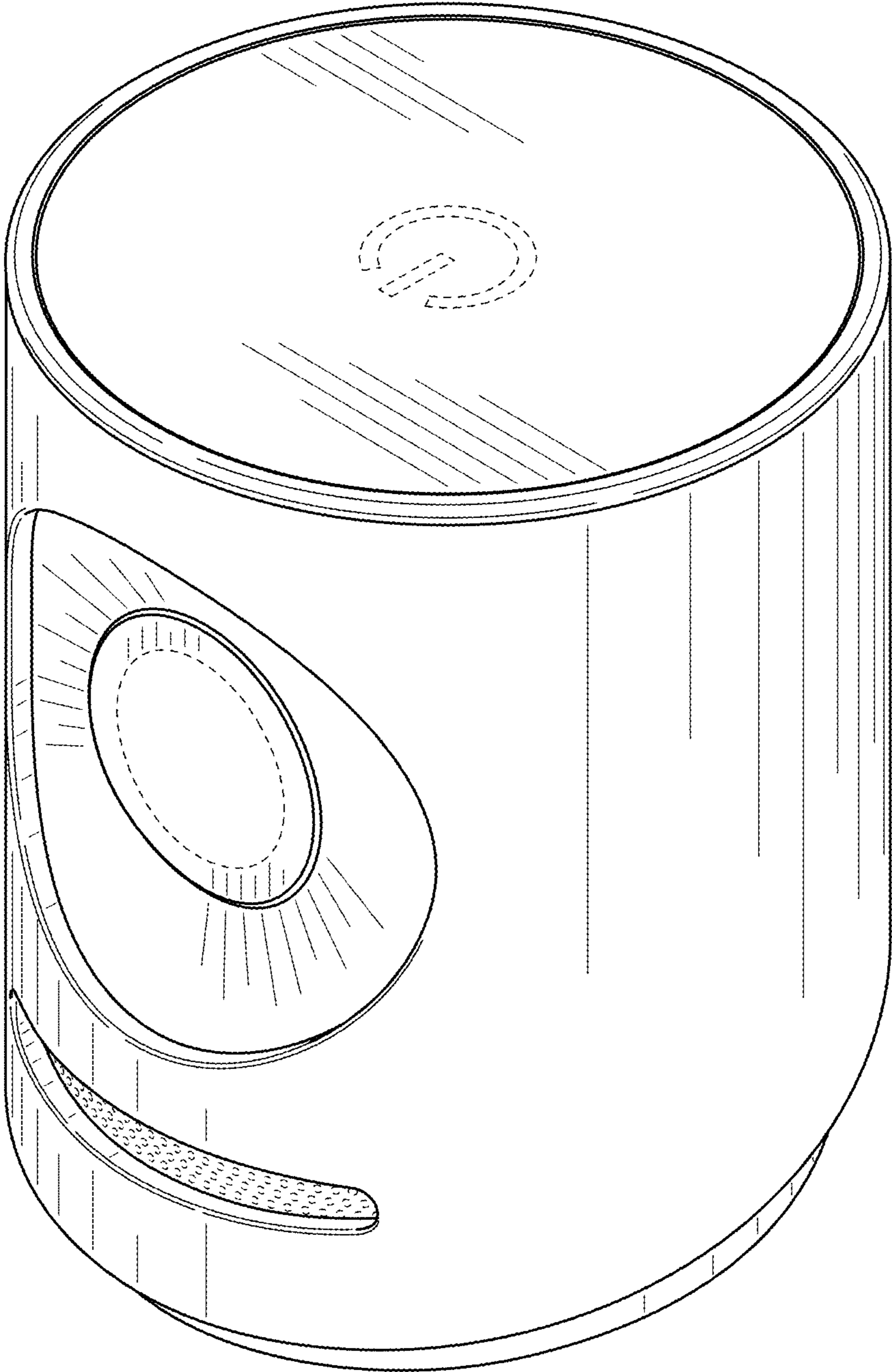

FIG. 1

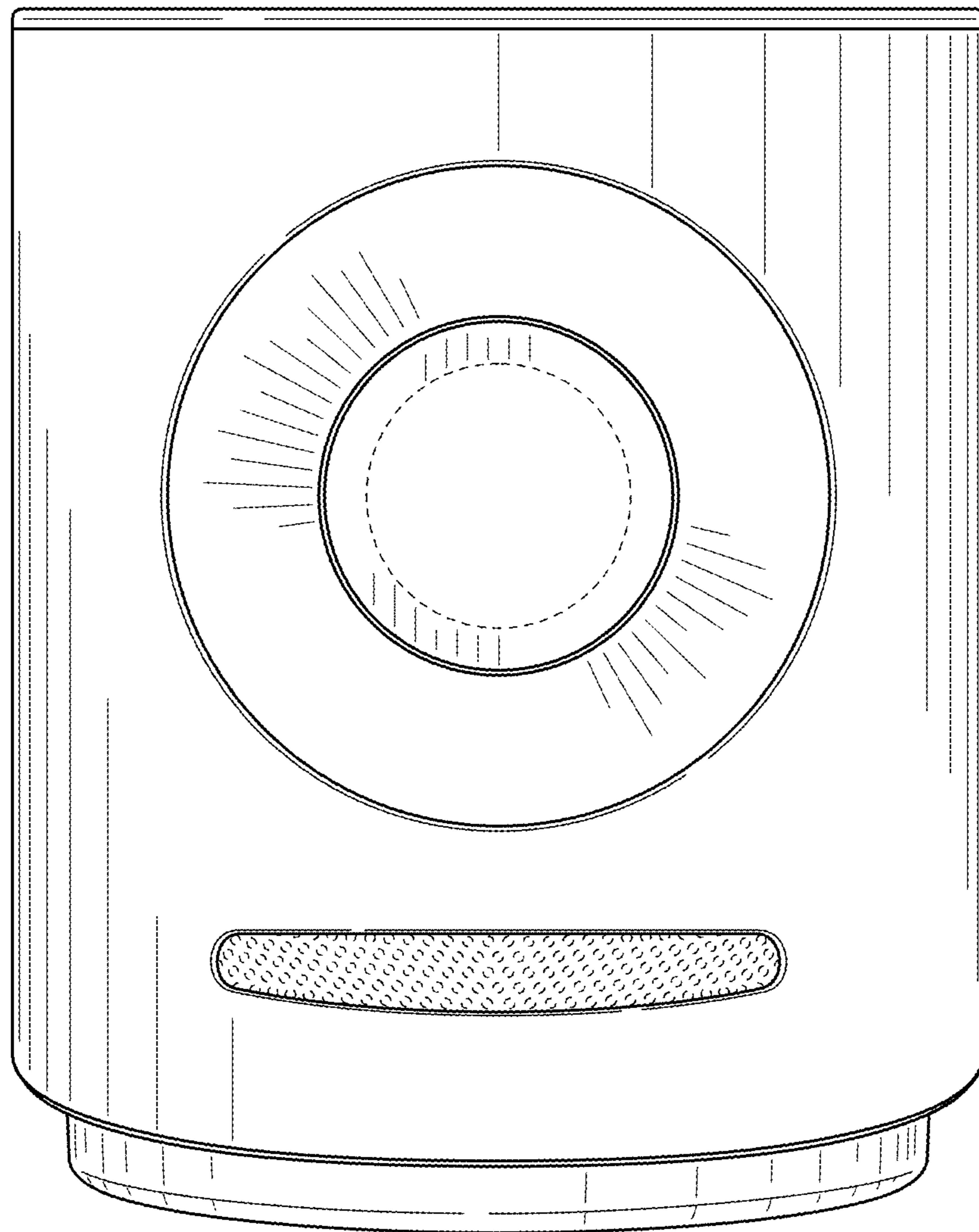

FIG. 2

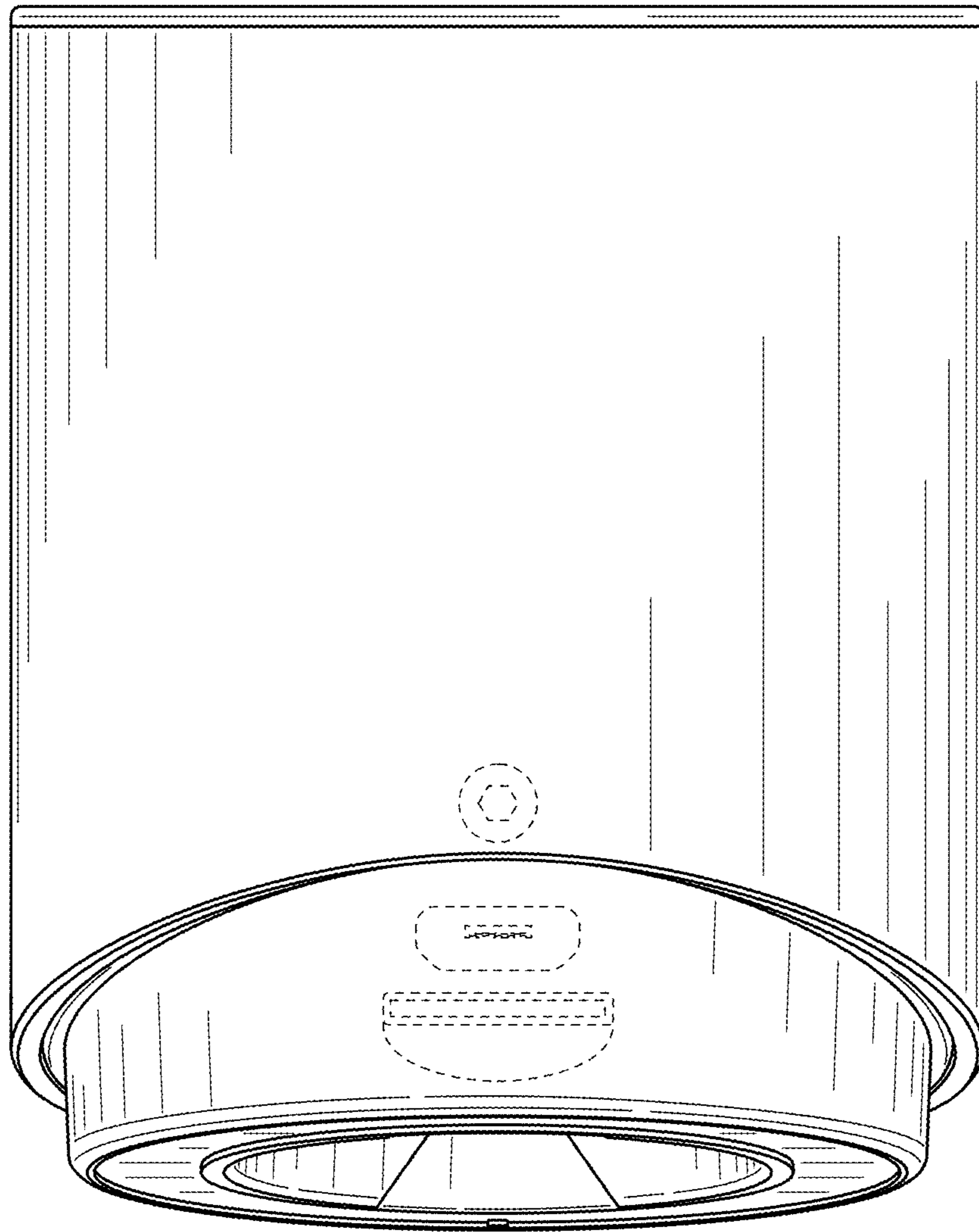

FIG. 3

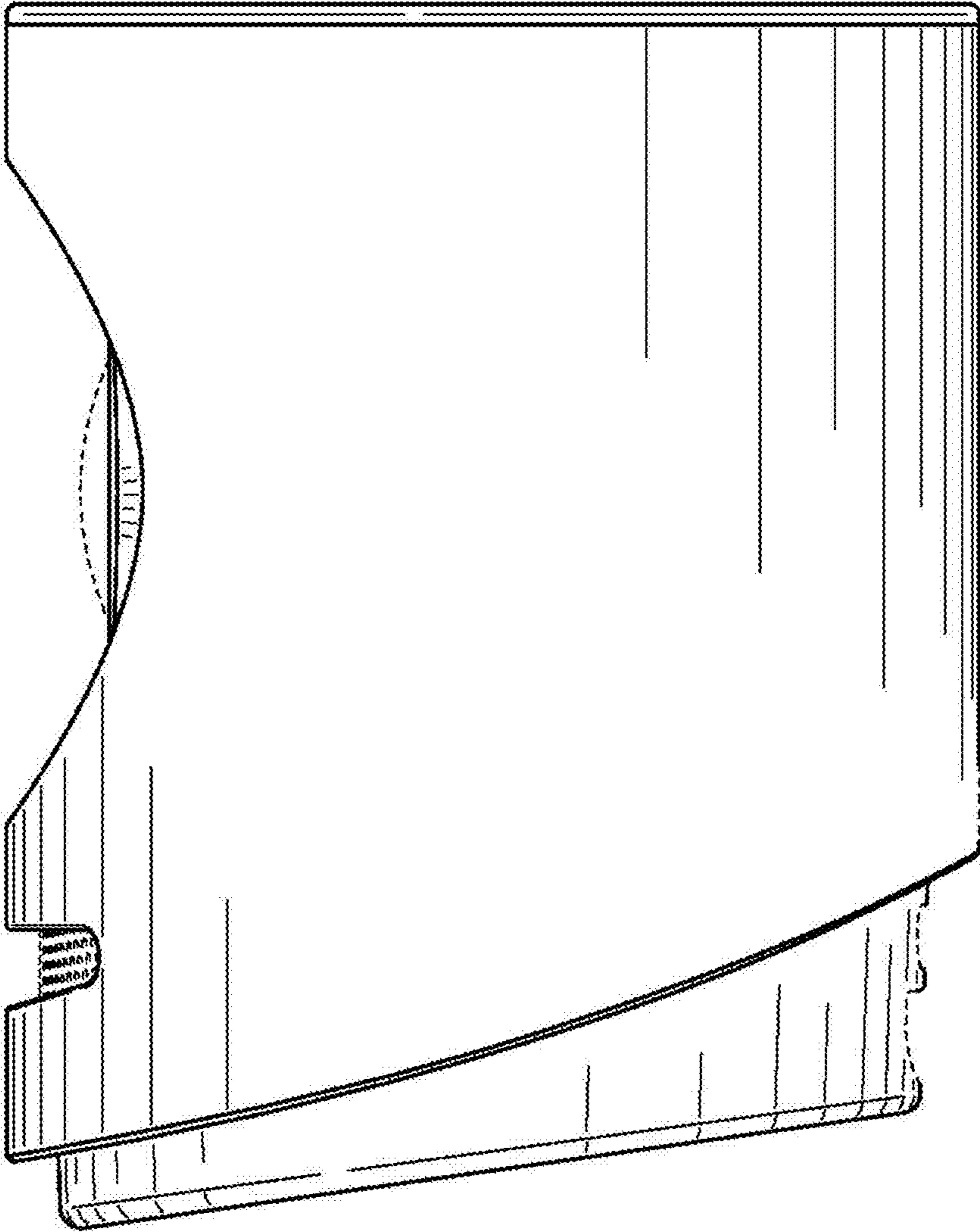

FIG. 4

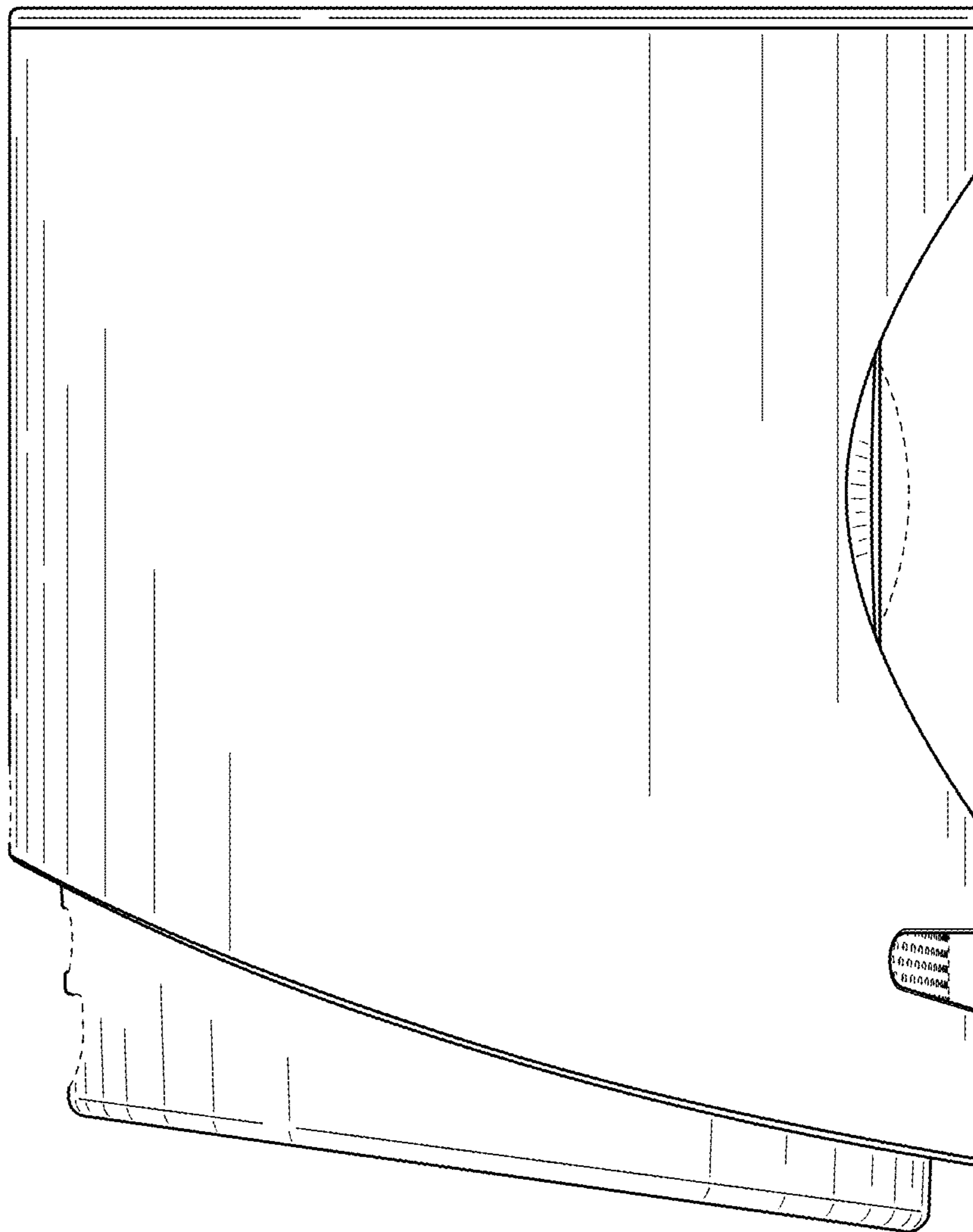

FIG. 5

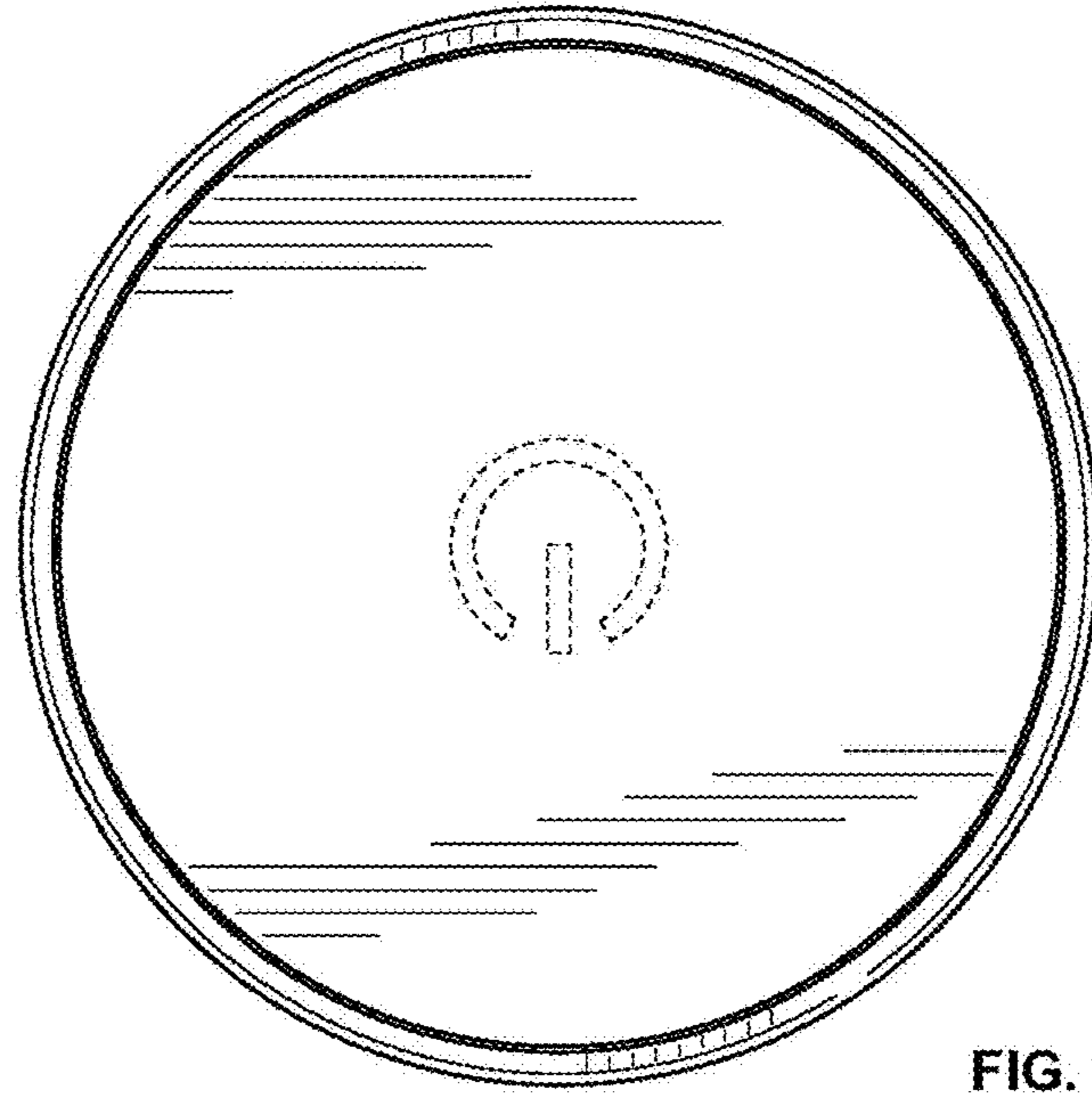

FIG. 6

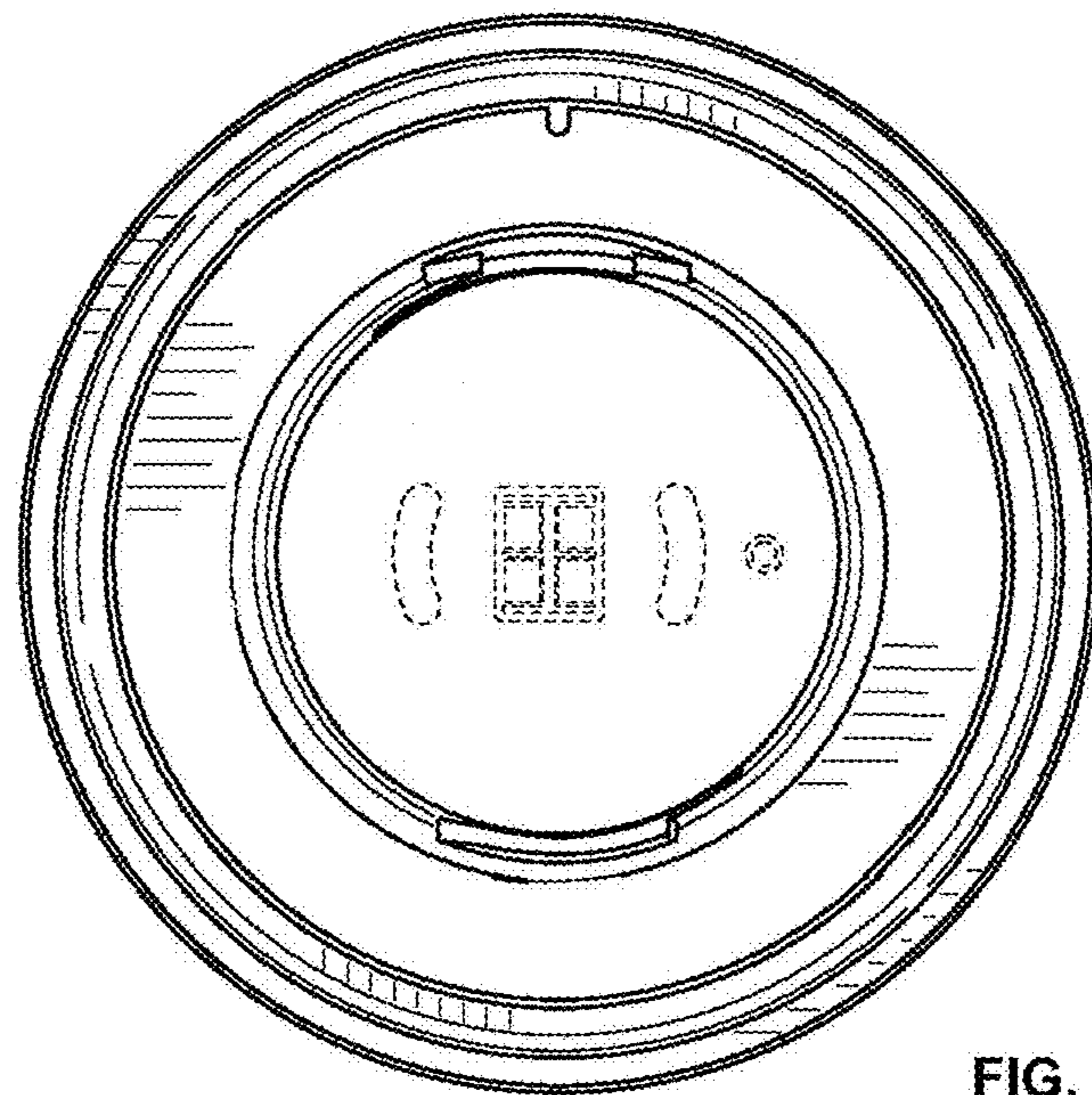

FIG. 7