



US00D807925S

(12) **United States Design Patent**
De Keyser et al.

(10) **Patent No.:** **US D807,925 S**

(45) **Date of Patent:** **** Jan. 16, 2018**

(54) **COMPRESSOR**

(71) Applicant: **ATLAS COPCO AIRPOWER N.V.**,
Wilrijk (BE)

(72) Inventors: **Karel De Keyser**, Wilrijk (BE); **Kristof**
Suykerbuyk, Wilrijk (BE)

(73) Assignee: **ATLAS COPCO AIRPOWER N.V.**,
Wilrijk (BE)

(**) Term: **15 Years**

(21) Appl. No.: **29/586,892**

(22) Filed: **Dec. 7, 2016**

(30) **Foreign Application Priority Data**

Jun. 2, 2016 (EM) 003168079-0001

(51) **LOC (11) Cl.** **15-02**

(52) **U.S. Cl.**
USPC **D15/9**

(58) **Field of Classification Search**
USPC D15/7-9; D23/231, 232, 225; 417/60,
417/235, 265, 321, 355, 358, 363, 359,
417/410.1, 415-416, 405, 900, 269, 539;
60/408, 412; 184/26-37; 415/140-147;
123/495, 509; 137/565.34
CPC F02M 37/04; F02M 37/14; F04B 53/92;
F04B 1/005

See application file for complete search history.

(56) **References Cited**

U.S. PATENT DOCUMENTS

2,778,315 A *	1/1957	Crookston	F04B 15/04 417/383
D183,115 S *	7/1958	Calloway	D15/9
D279,377 S *	6/1985	Kuchar	D15/7
D636,791 S *	4/2011	McAlpine	D15/7
D677,282 S *	3/2013	Soja	D15/7
D677,283 S *	3/2013	Soja	D15/7

* cited by examiner

Primary Examiner — Ralf T Seifert

(74) *Attorney, Agent, or Firm* — Bacon & Thomas, PLLC

(57) **CLAIM**

The ornamental design for compressor, as shown and described.

DESCRIPTION

FIG. 1 is a front perspective view of the invention.
FIG. 2 is a rear view thereof.
FIG. 3 is a right side view thereof.
FIG. 4 is a left side view thereof.
FIG. 5 is a front view thereof; and,
FIG. 6 is a top view thereof.

1 Claim, 6 Drawing Sheets

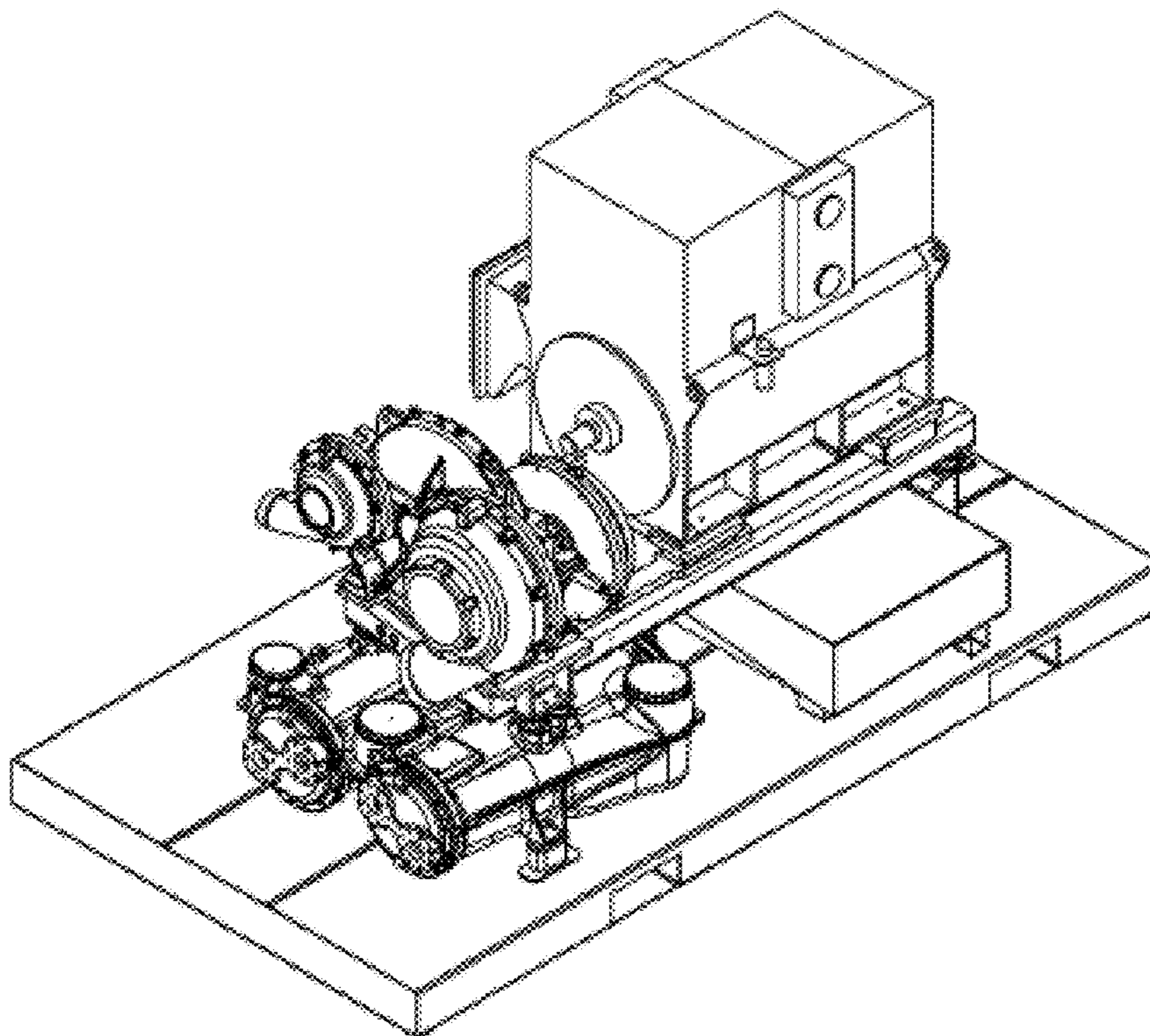

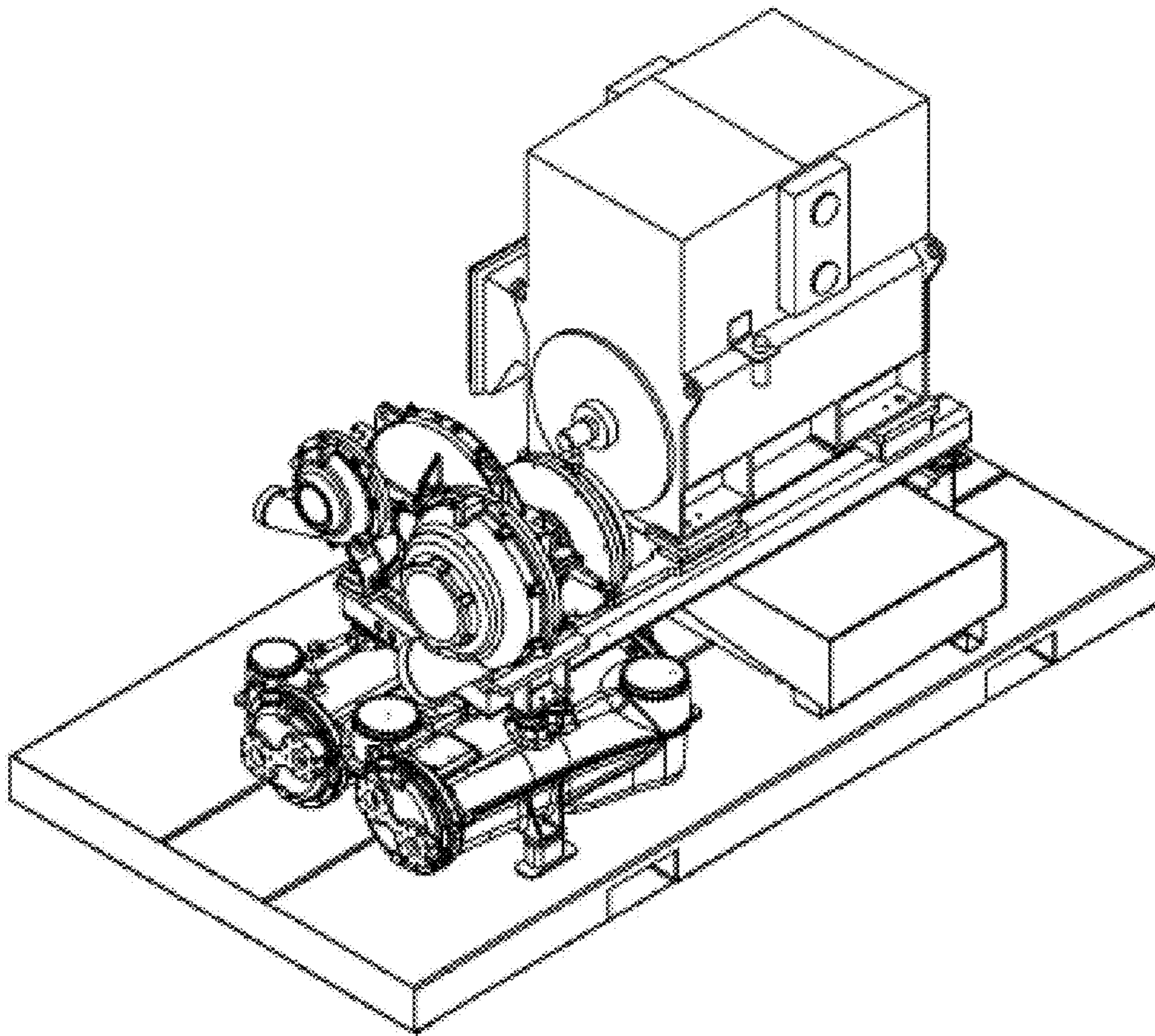

FIG. 1

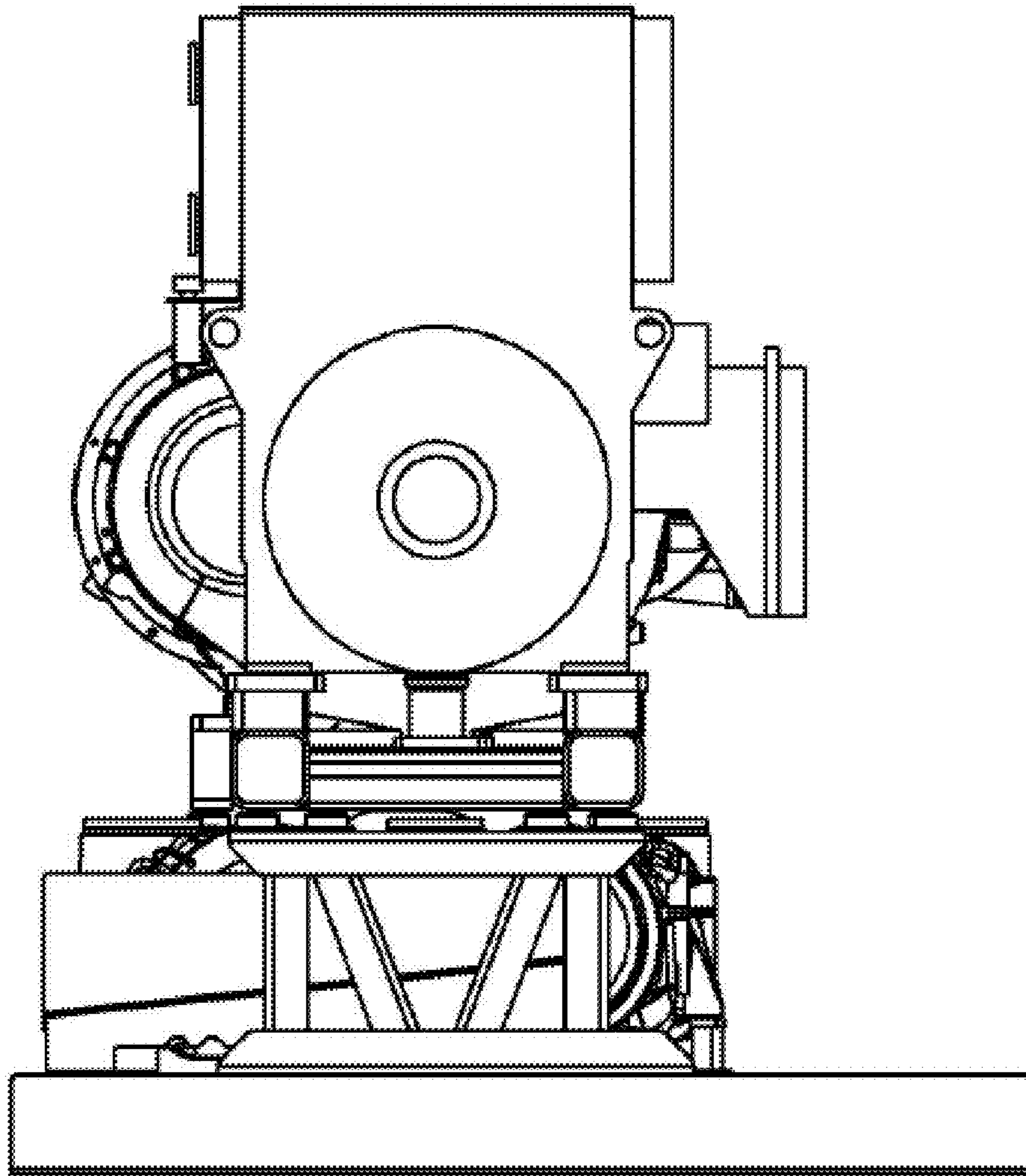

FIG. 2

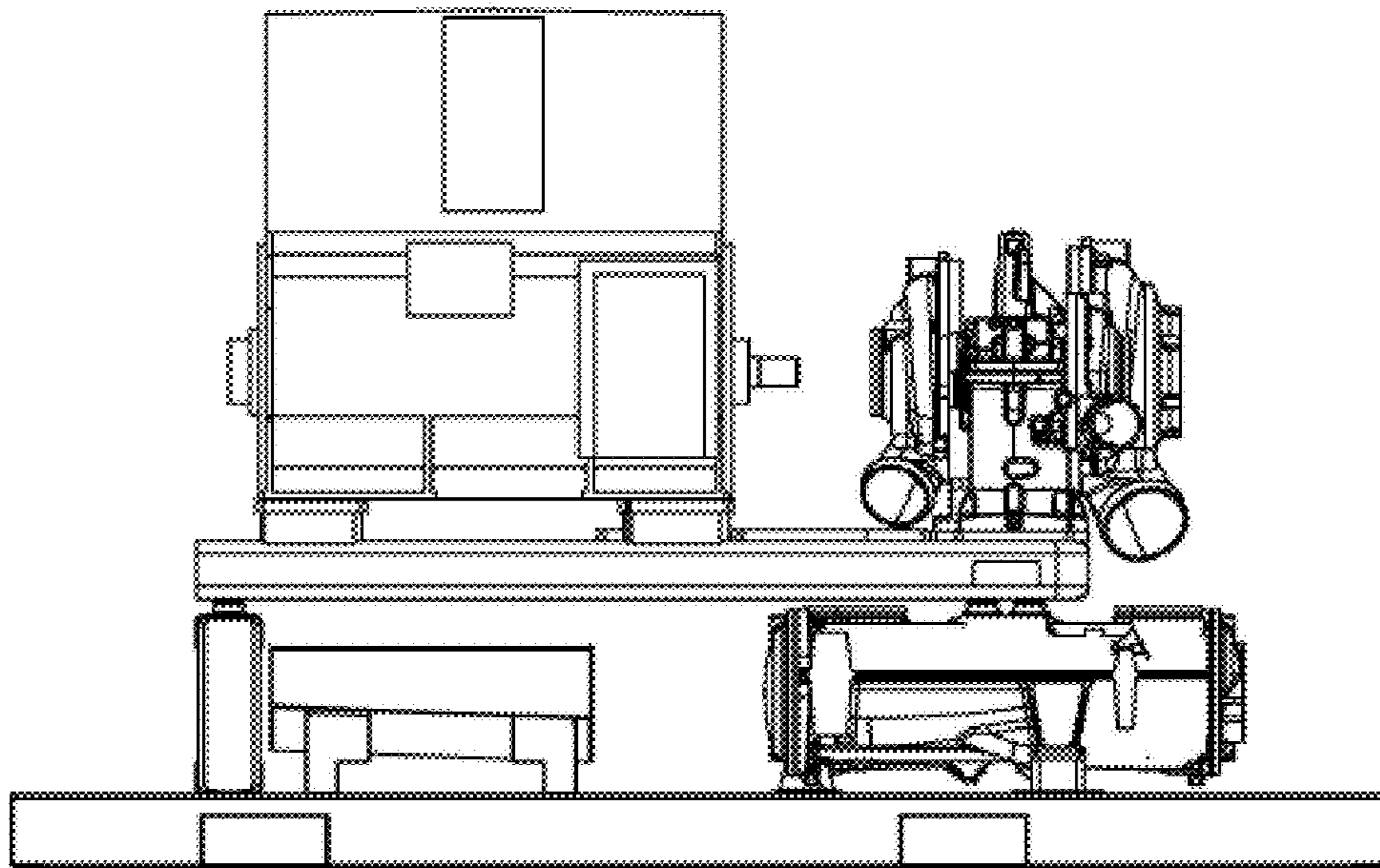

FIG. 3

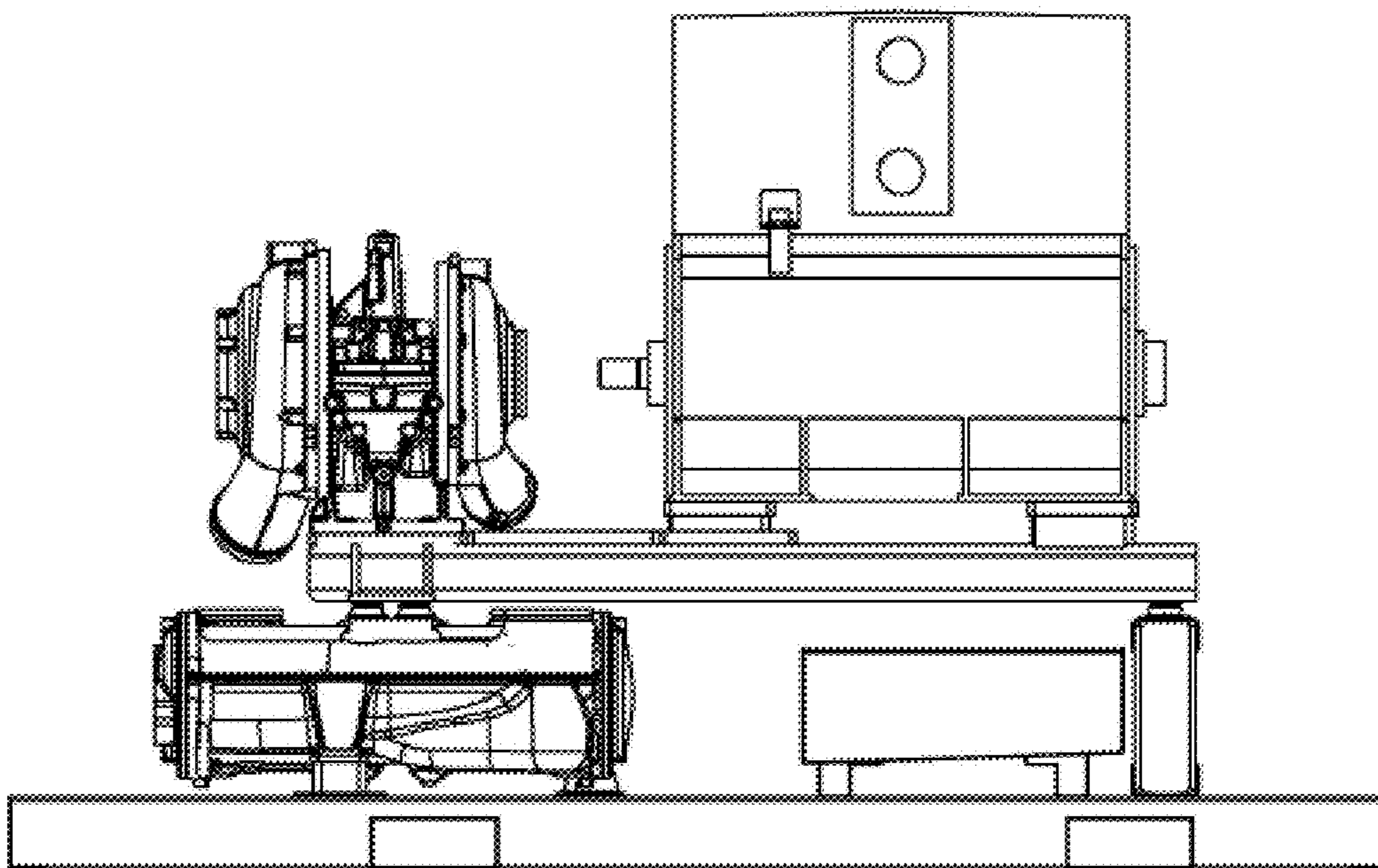

FIG. 4

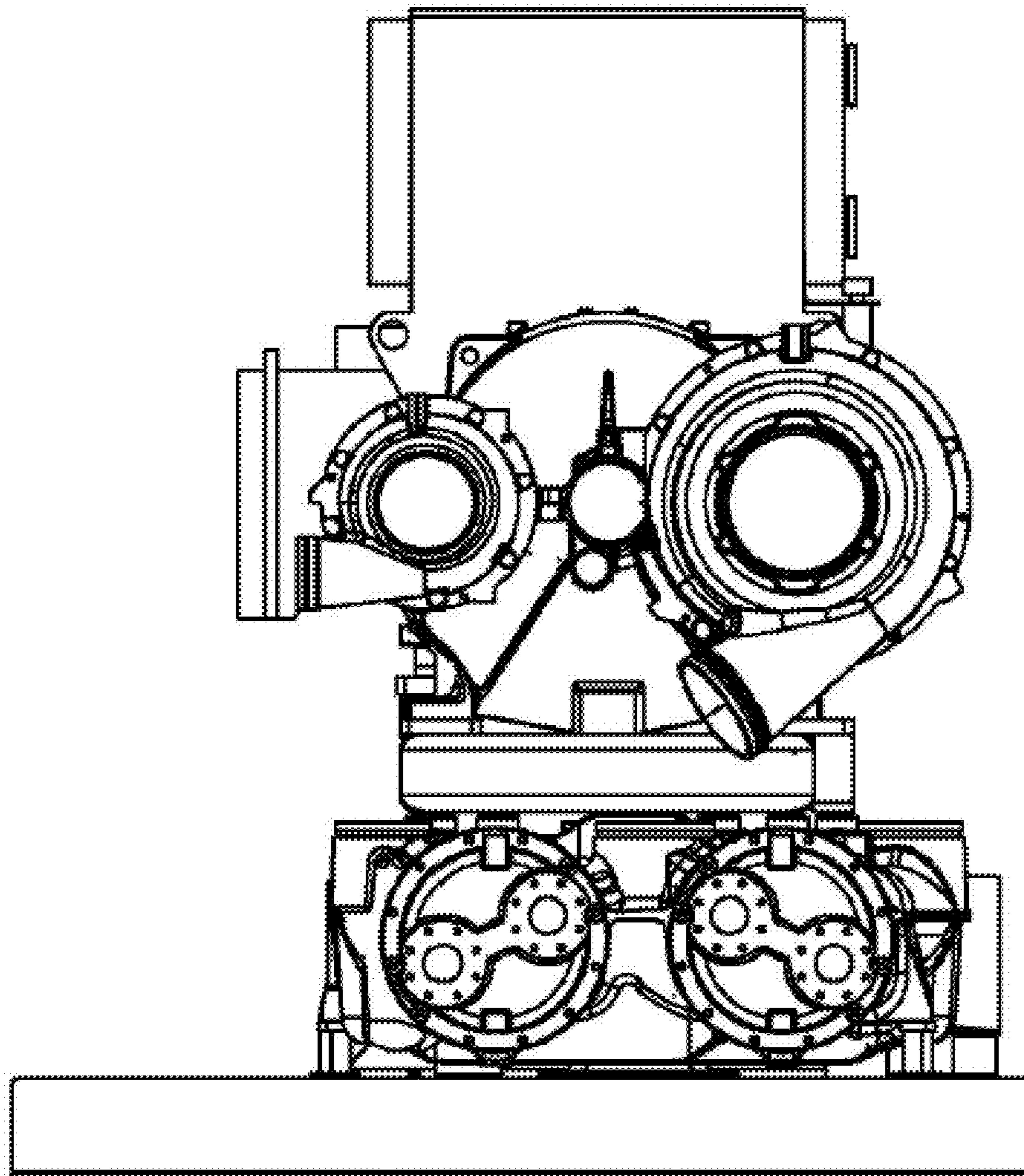

FIG. 5

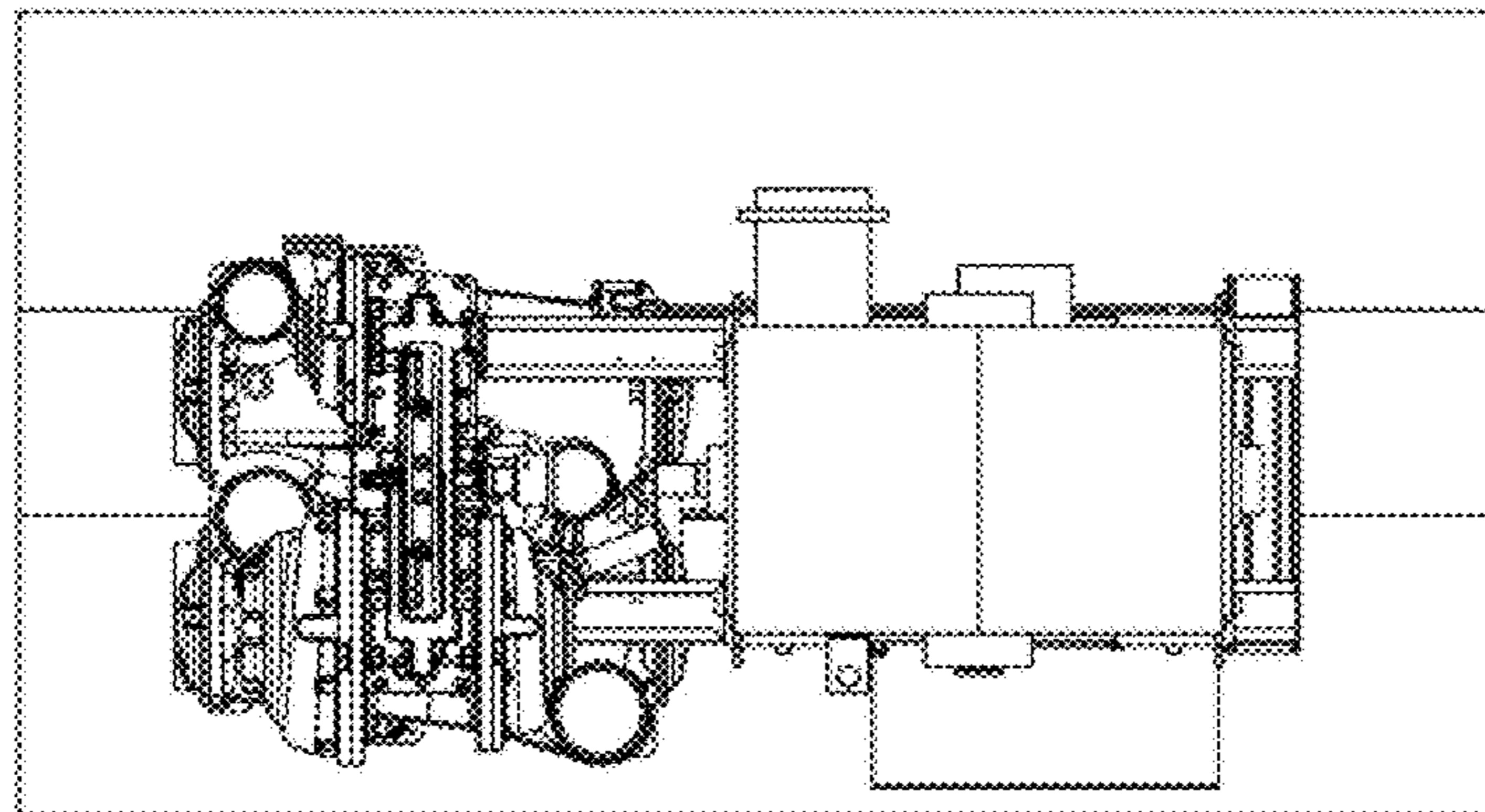

FIG. 6