



US00D807794S

(12) **United States Design Patent**  
**Guse et al.**

(10) **Patent No.:** **US D807,794 S**  
(45) **Date of Patent:** **\*\* Jan. 16, 2018**

(54) **SHOCK ABSORBING HUB ASSEMBLY FOR A MARINE PROPULSION APPARATUS**

(71) Applicant: **Brunswick Corporation**, Lake Forest, IL (US)

(72) Inventors: **Daniel J. Guse**, Fond du Lac, WI (US);  
**Jeremy L. Alby**, Oshkosh, WI (US);  
**Jeffrey C. Etapa**, Oakfield, WI (US)

(73) Assignee: **Brunswick Corporation**, Mettawa, IL (US)

(\*\*) Term: **15 Years**

(21) Appl. No.: **29/549,282**

(22) Filed: **Dec. 21, 2015**

**Related U.S. Application Data**

(63) Continuation-in-part of application No. 14/943,187, filed on Nov. 17, 2015.

(51) **LOC (11) Cl.** ..... **12-16**

(52) **U.S. Cl.**  
USPC ..... **D12/159**

(58) **Field of Classification Search**  
USPC ..... D12/87-88, 93, 159-161, 400-401, 406,  
D12/412, 414, 414.1

(Continued)

(56) **References Cited**

**U.S. PATENT DOCUMENTS**

4,642,057 A 2/1987 Frazzell et al.  
5,244,348 A 9/1993 Karls et al.

(Continued)

**OTHER PUBLICATIONS**

Mercury Marine to release new Flo-Torq propeller hub system, posted at Mercurymarine.com, posted on Jul. 30, 2015, site visited Apr. 11, 2017, <<https://www.mercurymarine.com/en/us/news/mer->

[cury-marine-to-release-new-flo-torq-propeller-hub-system/?utm\\_term=en&utm\\_medium=ca+&utm\\_source=Overlay\\_IP%3Dus&utm\\_campaign=Region+Redirection](https://www.mercurymarine.com/en/us/news/mercury-marine-to-release-new-flo-torq-propeller-hub-system/?utm_term=en&utm_medium=ca+&utm_source=Overlay_IP%3Dus&utm_campaign=Region+Redirection)>.\*

(Continued)

*Primary Examiner* — Barbara Fox

*Assistant Examiner* — Messina L Smith

(74) *Attorney, Agent, or Firm* — Andrus Intellectual Property Law, LLP

(57) **CLAIM**

The ornamental design for a shock absorbing hub assembly for a marine propulsion apparatus, as shown and described.

**DESCRIPTION**

FIG. 1 is a front perspective view of a body of a shock absorbing hub assembly for a marine propulsion apparatus, showing the new design, showing the body portion separated from the assembly for ease of illustration;

FIG. 2 is a top view thereof;

FIG. 3 is a bottom view thereof;

FIG. 4 is an end view thereof;

FIG. 5 is an opposite end view thereof;

FIG. 6 is a front perspective view of a hub component for the shock absorbing hub assembly, showing the body portion separated from the assembly for ease of illustration;

FIG. 7 is a top view thereof;

FIG. 8 is a bottom view thereof;

FIG. 9 is an end view thereof;

FIG. 10 is an opposite end view thereof;

FIG. 11 is a front perspective view of the shock absorbing hub assembly showing the new design, with the body and the elastic hub component assembled;

FIG. 12 is a top view thereof;

FIG. 13 is a bottom view thereof;

FIG. 14 is an end view thereof; and,

FIG. 15 is an opposite end view thereof.

The broken lines in the drawings illustrate portions of the shock absorbing hub assembly for a marine propulsion apparatus that form no part of the claimed design.

**1 Claim, 6 Drawing Sheets**

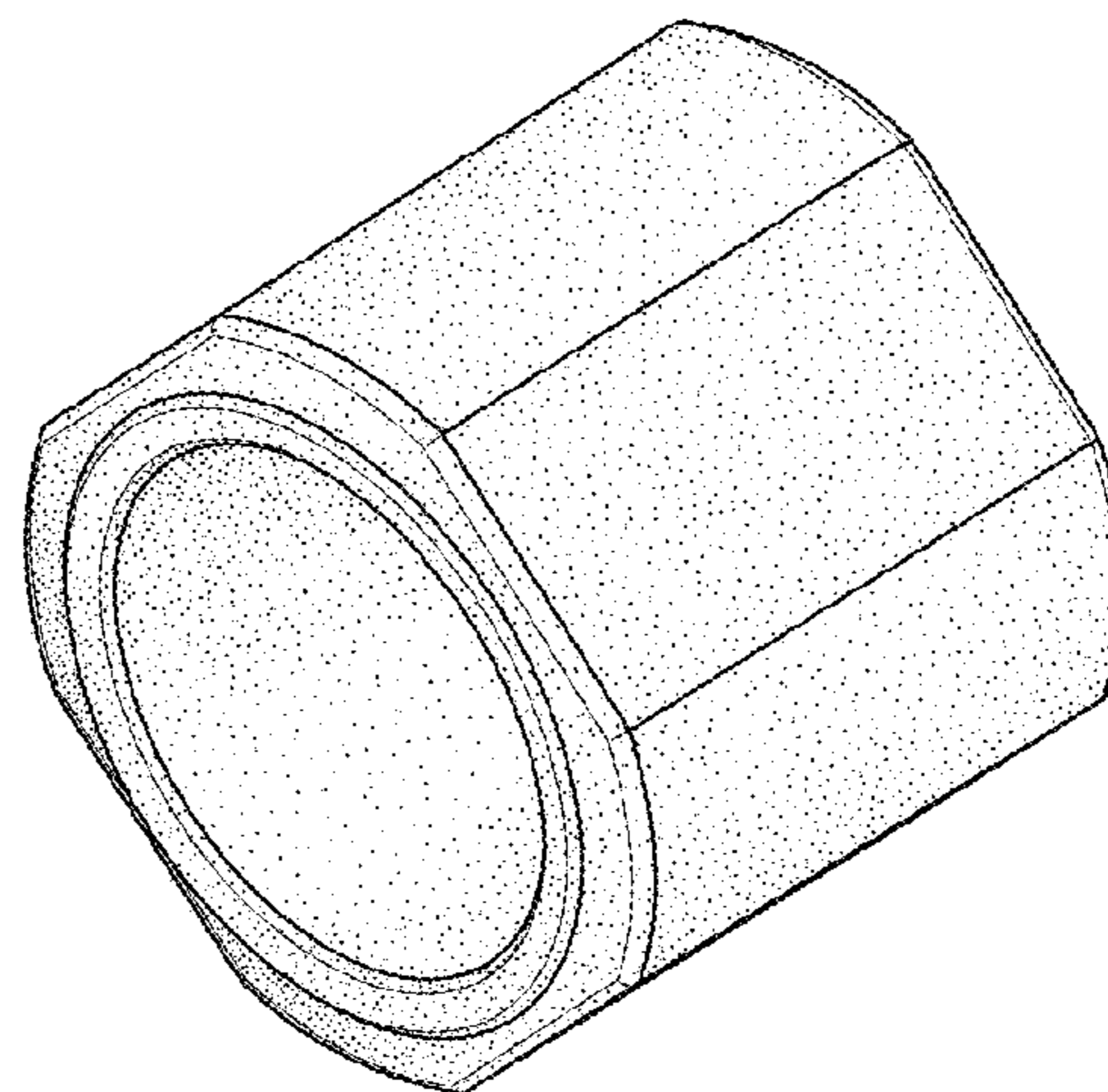
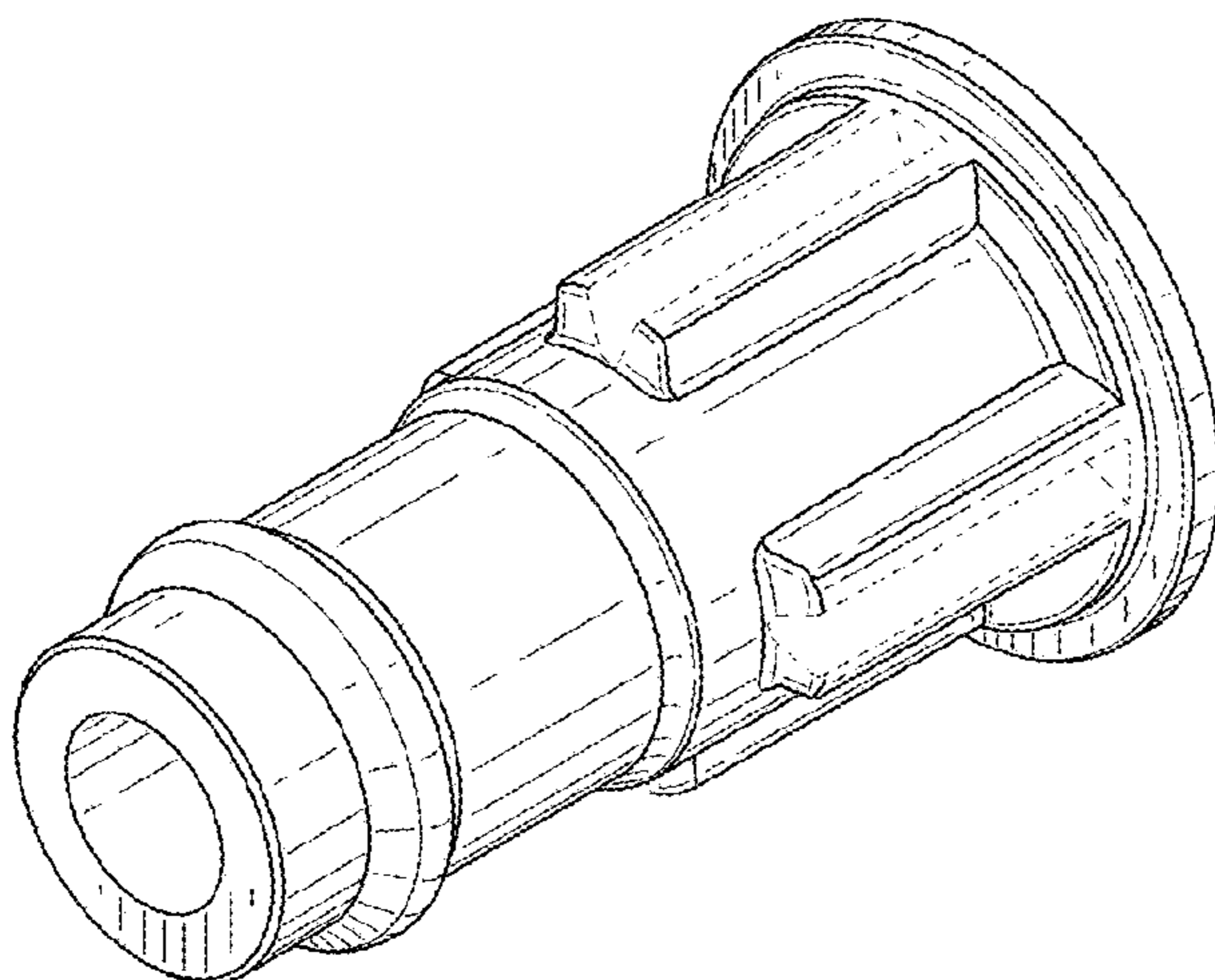

# US D807,794 S

Page 2

(58) **Field of Classification Search**

CPC .. B60R 9/00; B60R 9/06; B60R 3/005; B60R 13/00; Y10T 70/7638; Y10T 70/7655; Y10T 70/7667; F16F 9/3242; F16F 9/0218; F16F 9/0227; F16F 9/3221; F16F 9/3235; B60G 11/22; B60G 2204/125; B60G 2204/41; B60G 2202/143; B60G 2202/142; B60G 2202/14; B60P 9/00; B60P 3/40

See application file for complete search history.

D645,382 S \* 9/2011 Verbowski ..... D12/159  
D658,481 S \* 5/2012 Pratt ..... D8/349  
D661,975 S \* 6/2012 Mahaffey ..... D8/330  
8,277,269 B1 10/2012 Alby et al.  
8,419,489 B2 4/2013 Tsunekawa et al.  
D771,434 S \* 11/2016 Burrows ..... D7/399  
D782,956 S \* 4/2017 Scott ..... D12/400  
2012/0167369 A1\* 7/2012 Holcomb ..... E05B 67/365  
29/428  
2014/0109328 A1\* 4/2014 Rauch ..... A61B 90/70  
15/104.05  
2014/0205455 A1 7/2014 Kuroki

(56)

**References Cited**

U.S. PATENT DOCUMENTS

5,322,416 A 6/1994 Karls et al.  
5,548,981 A \* 8/1996 Kirk ..... E05B 17/0062  
292/331  
6,478,543 B1 11/2002 Tuchscherer et al.  
D515,399 S \* 2/2006 Ho ..... D8/330  
7,234,330 B2\* 6/2007 Tseng ..... E05B 27/083  
70/375

OTHER PUBLICATIONS

Mercury Marine Wins International Innovation Award, posted at Bassanglermag.com, posted on May 4, 2016, site visited Apr. 11, 2017, <<http://bassanglermag.com/mercury-marine-wins-international-innovation-award/>>.\*

\* cited by examiner

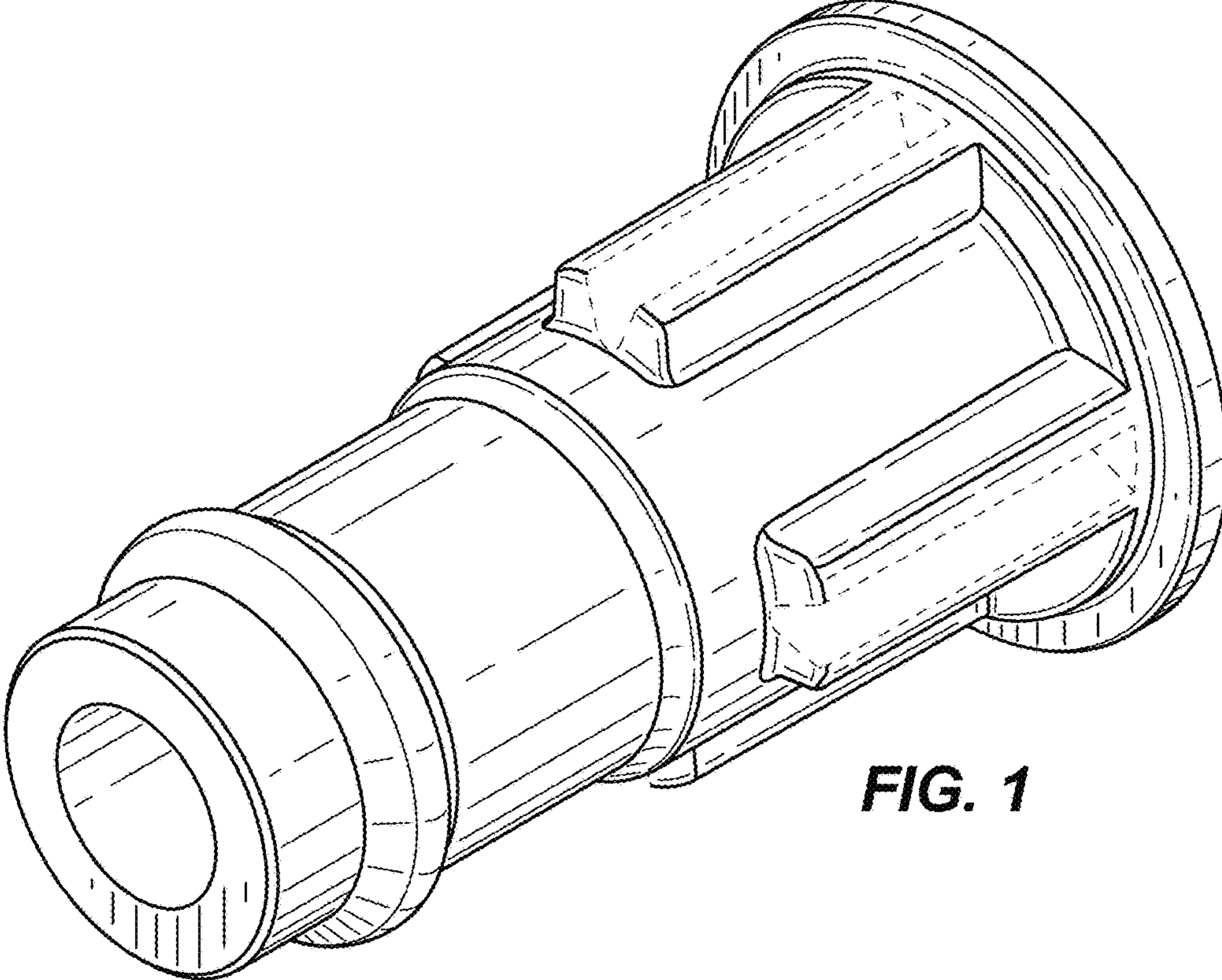

**FIG. 1**

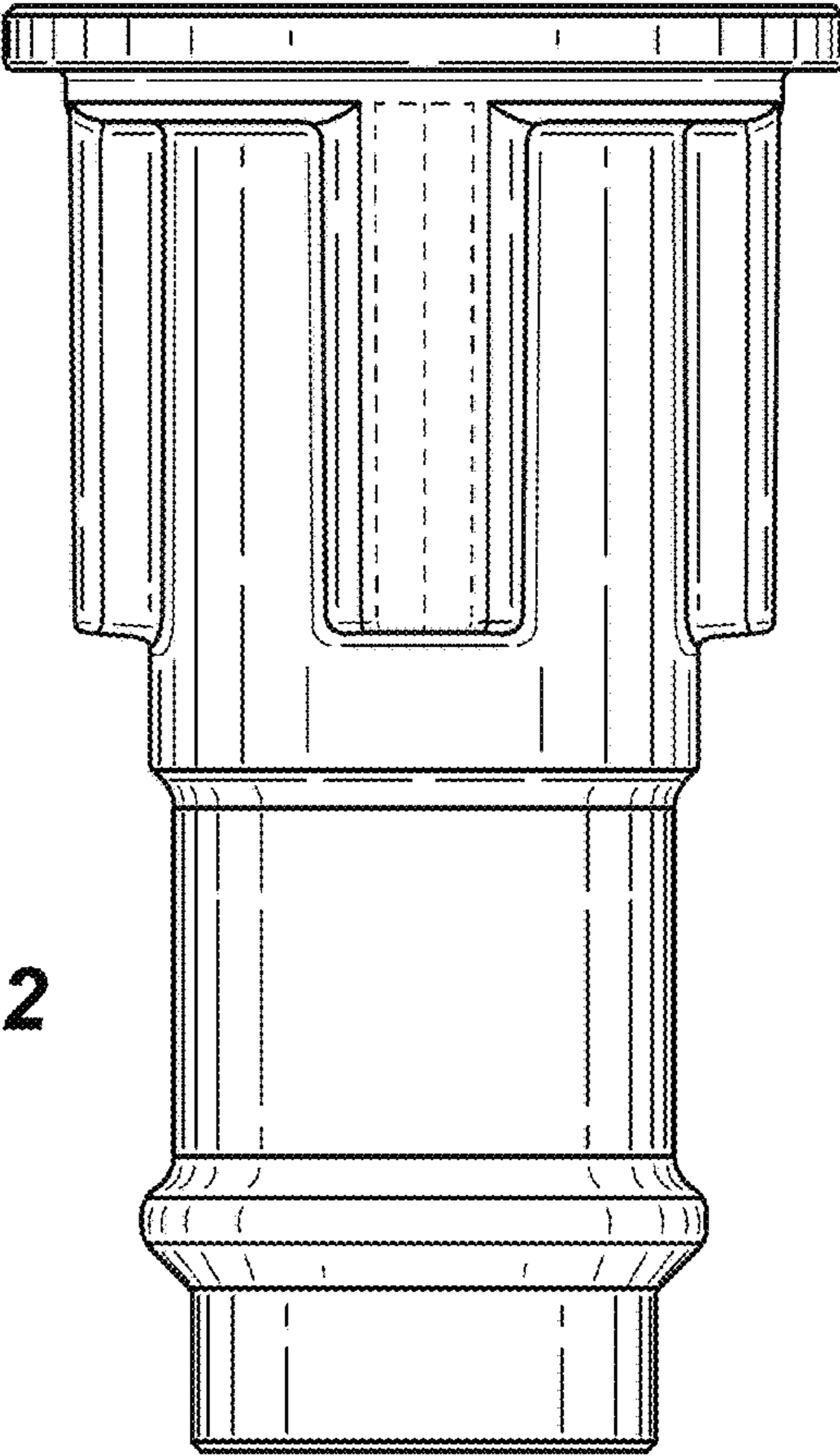

**FIG. 2**

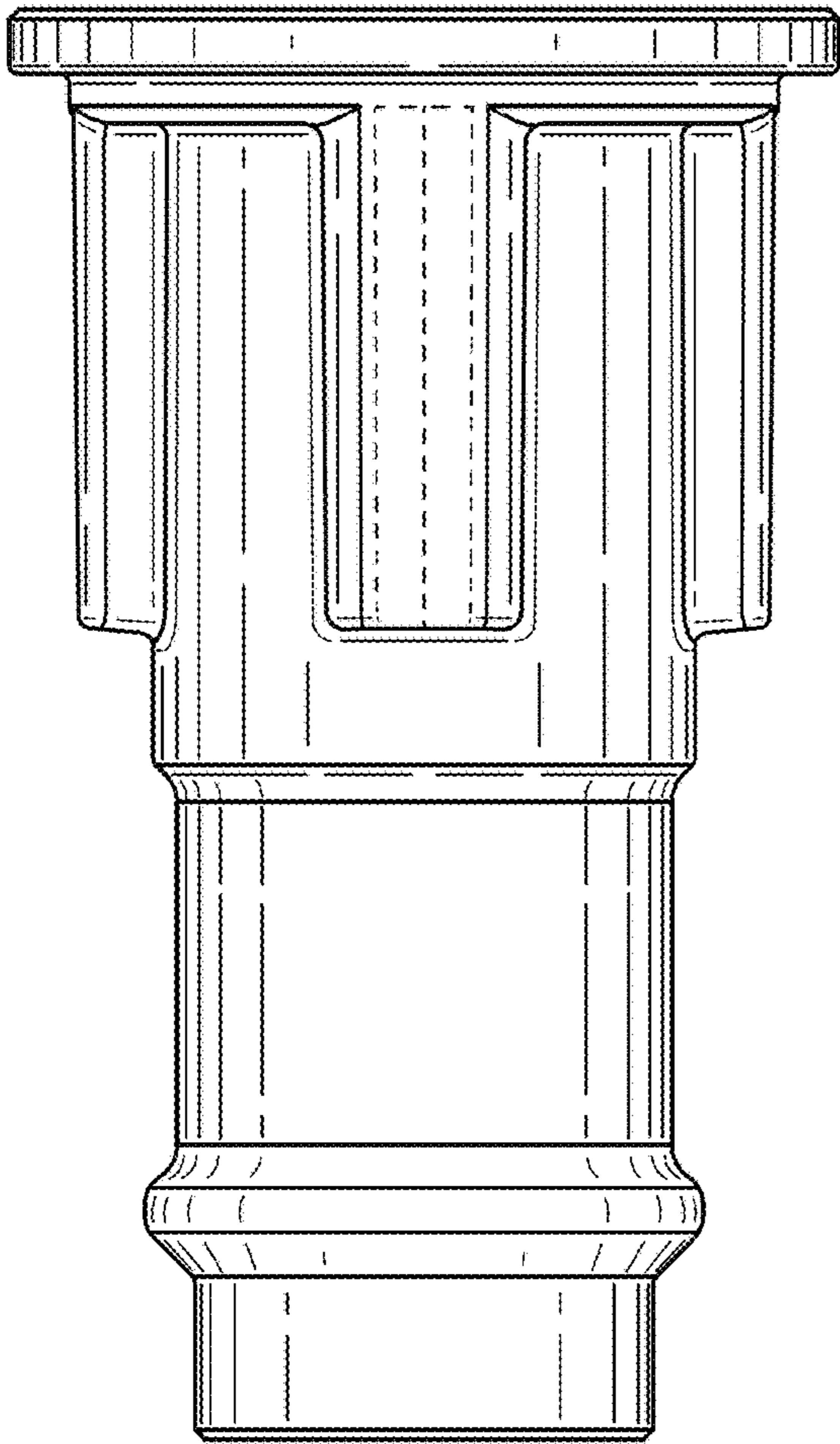

**FIG. 3**

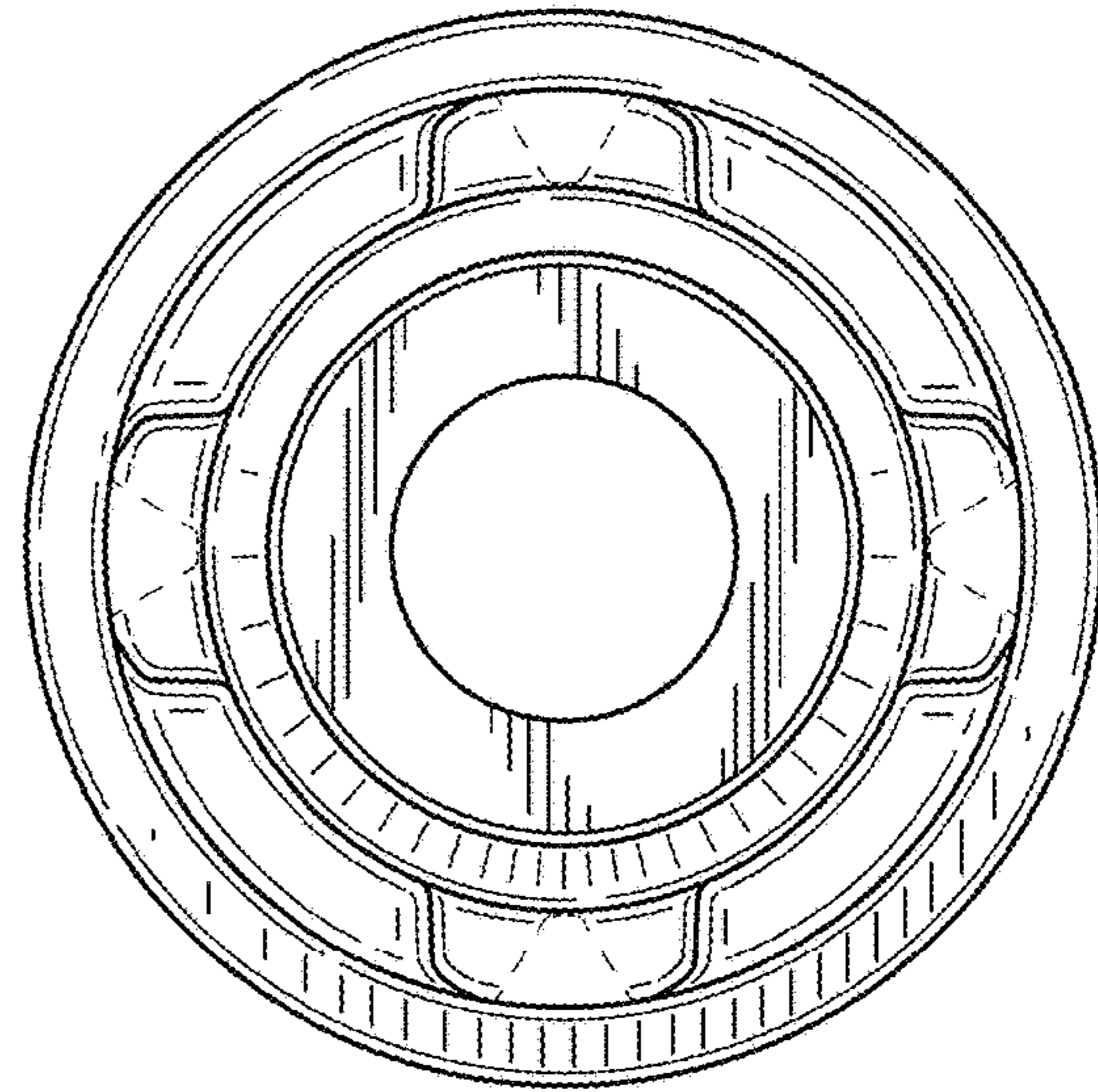

**FIG. 4**

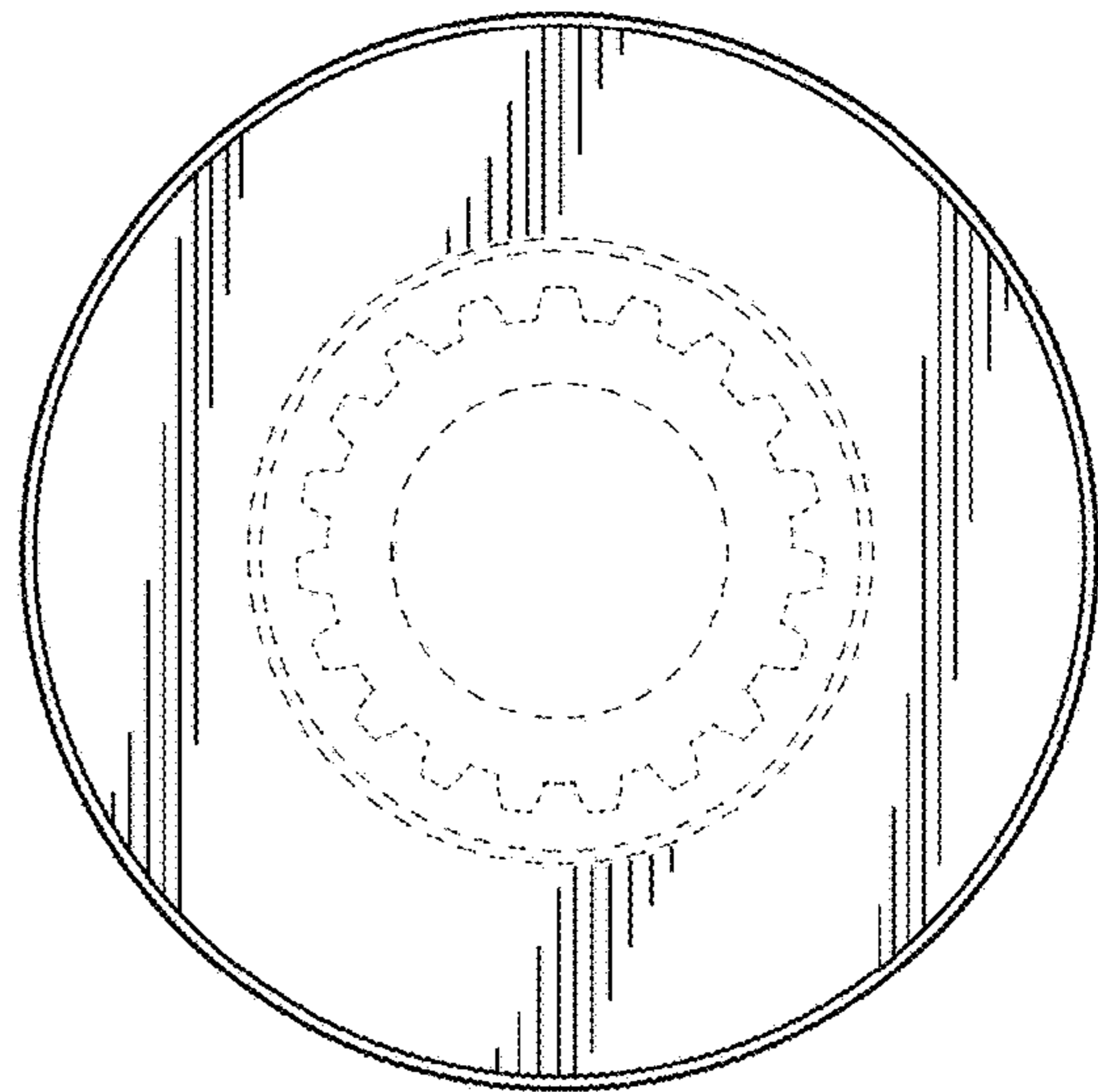

**FIG. 5**

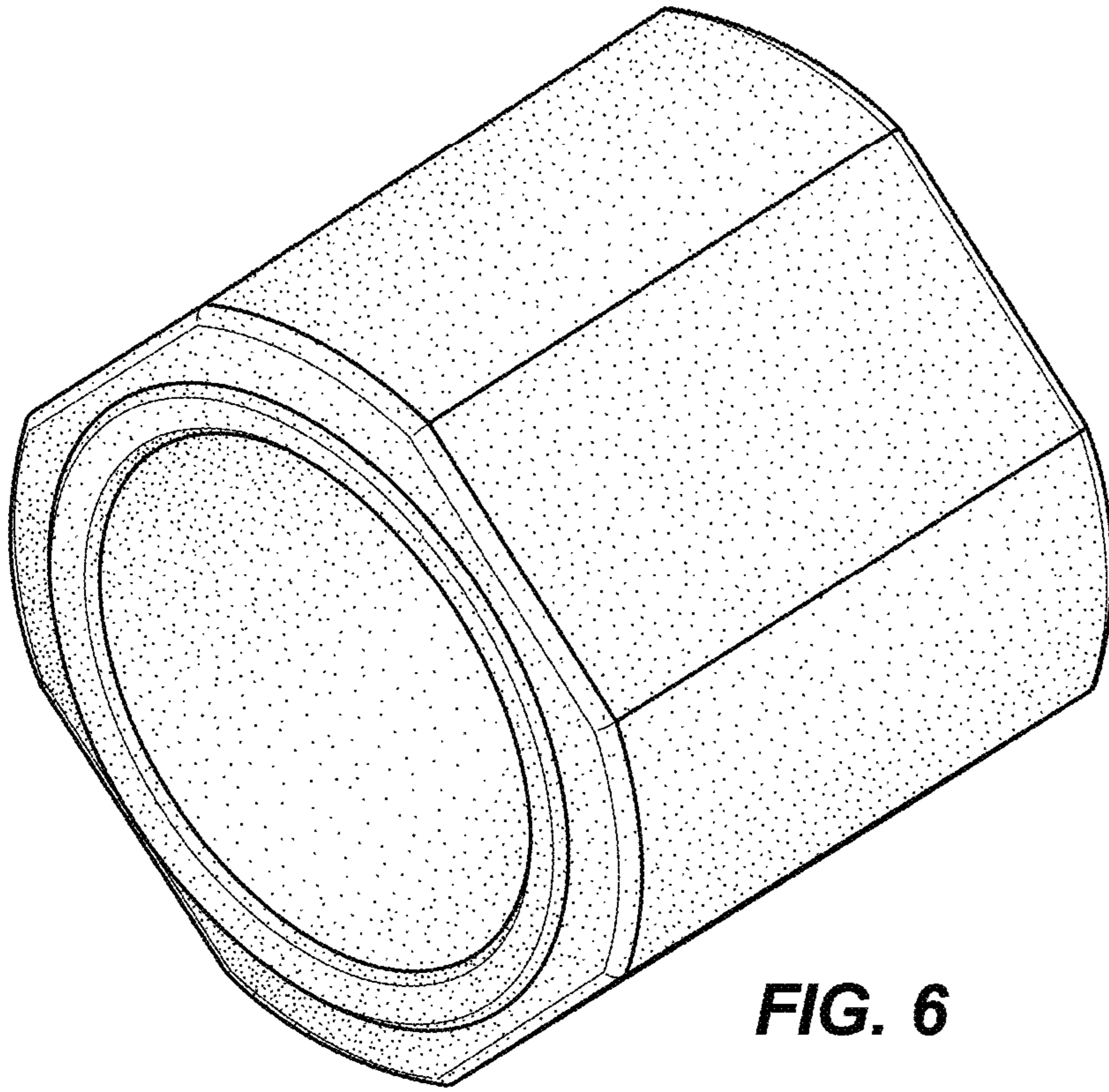

**FIG. 6**

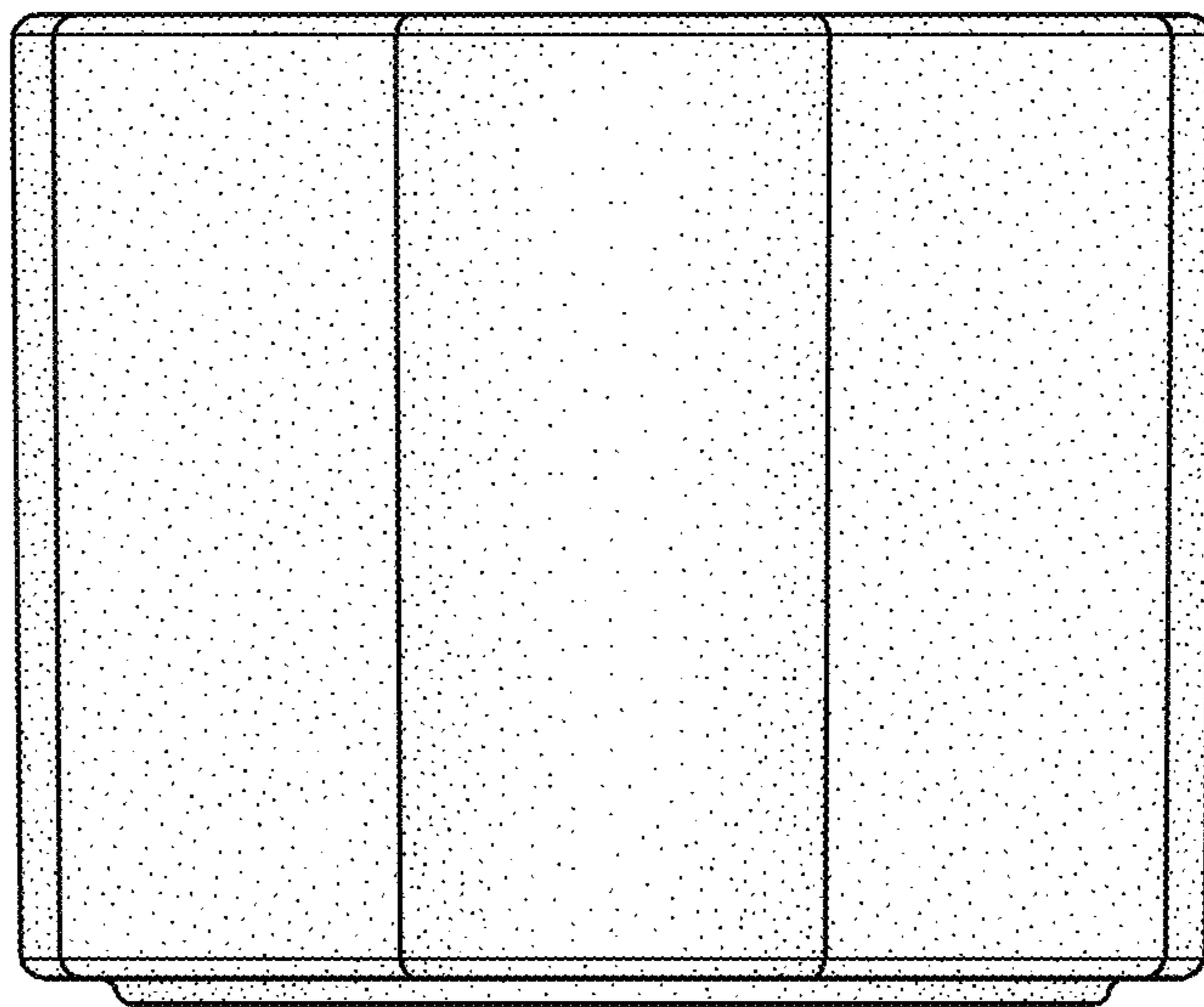

**FIG. 7**

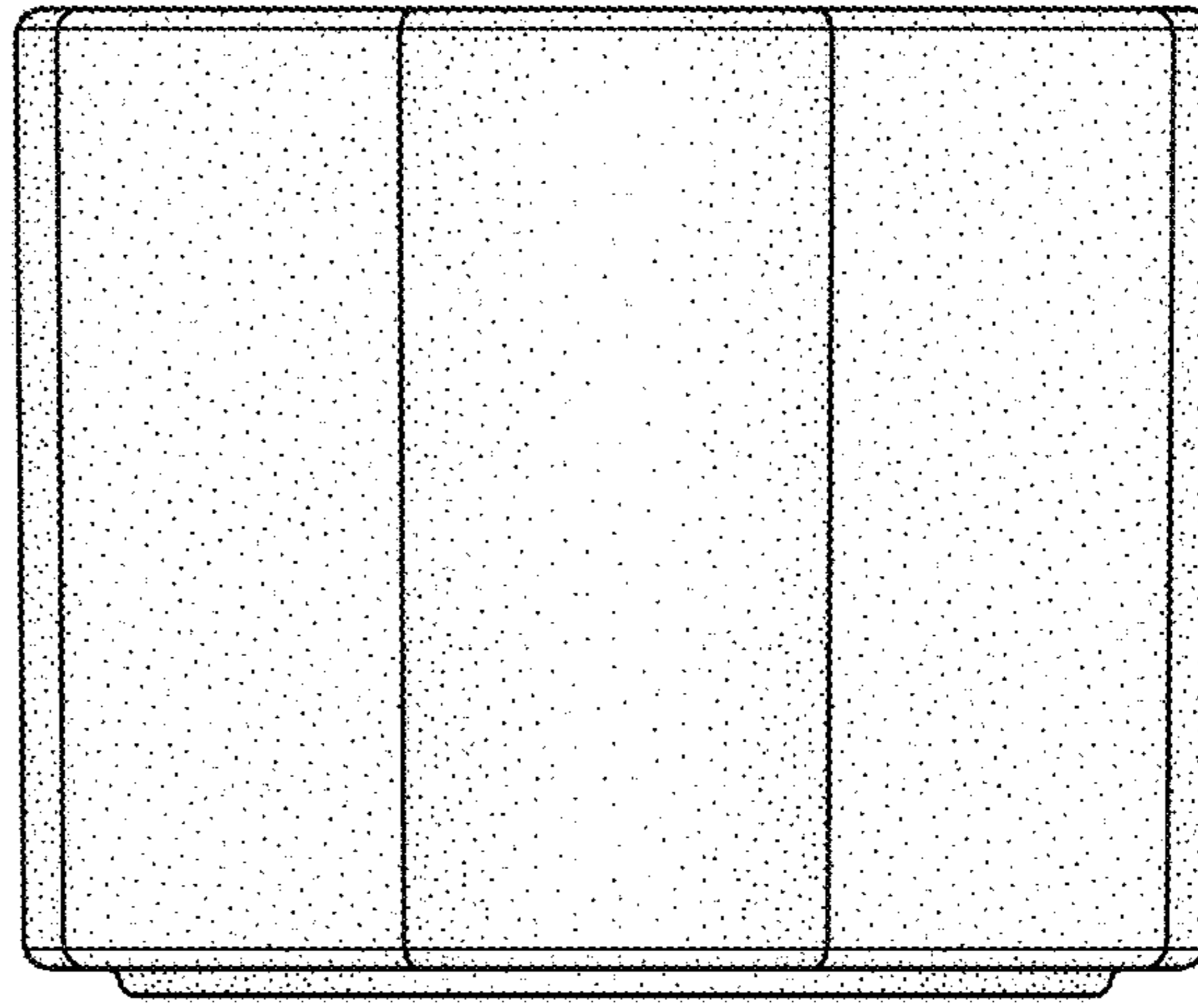

**FIG. 8**

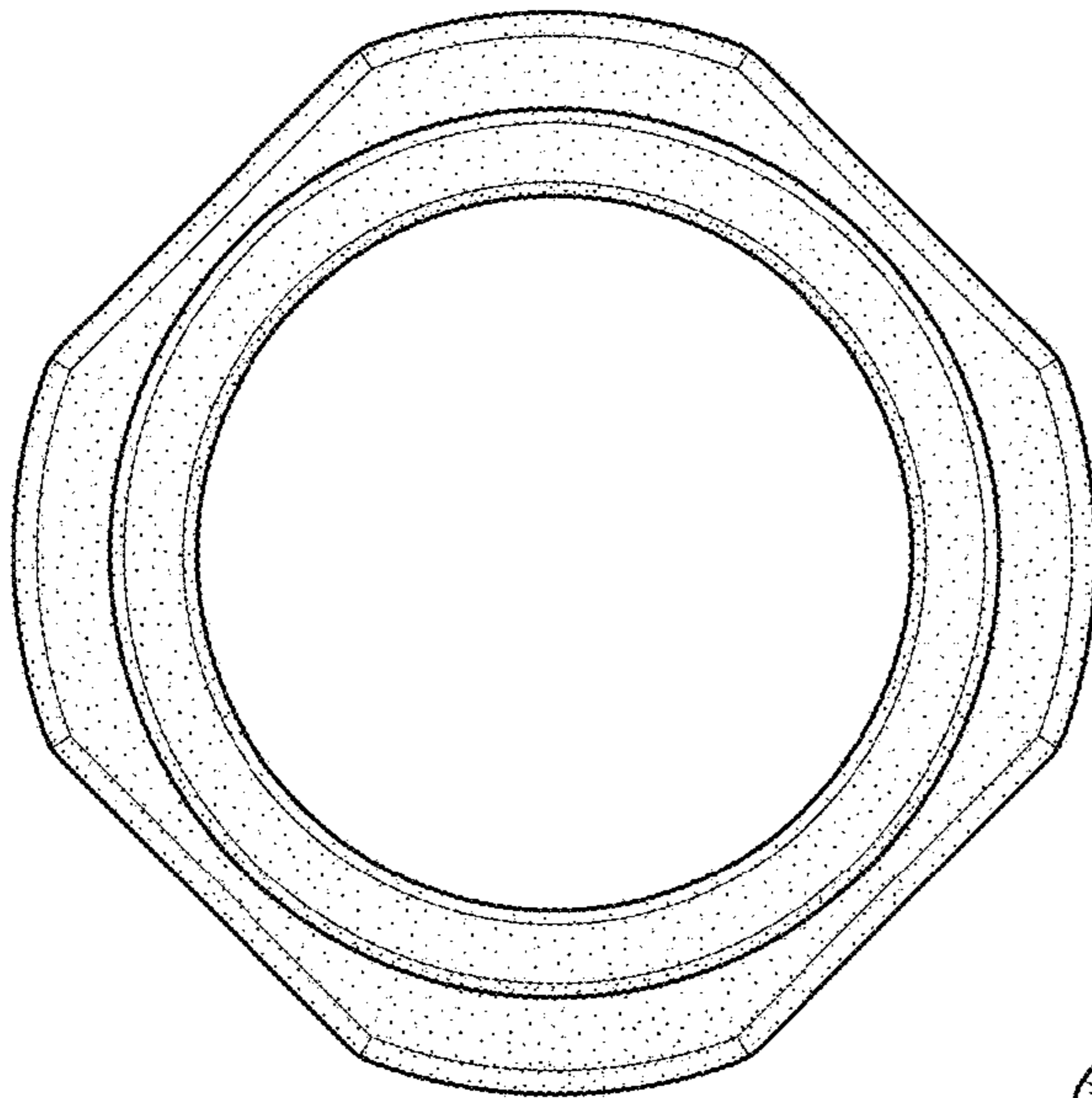

**FIG. 9**

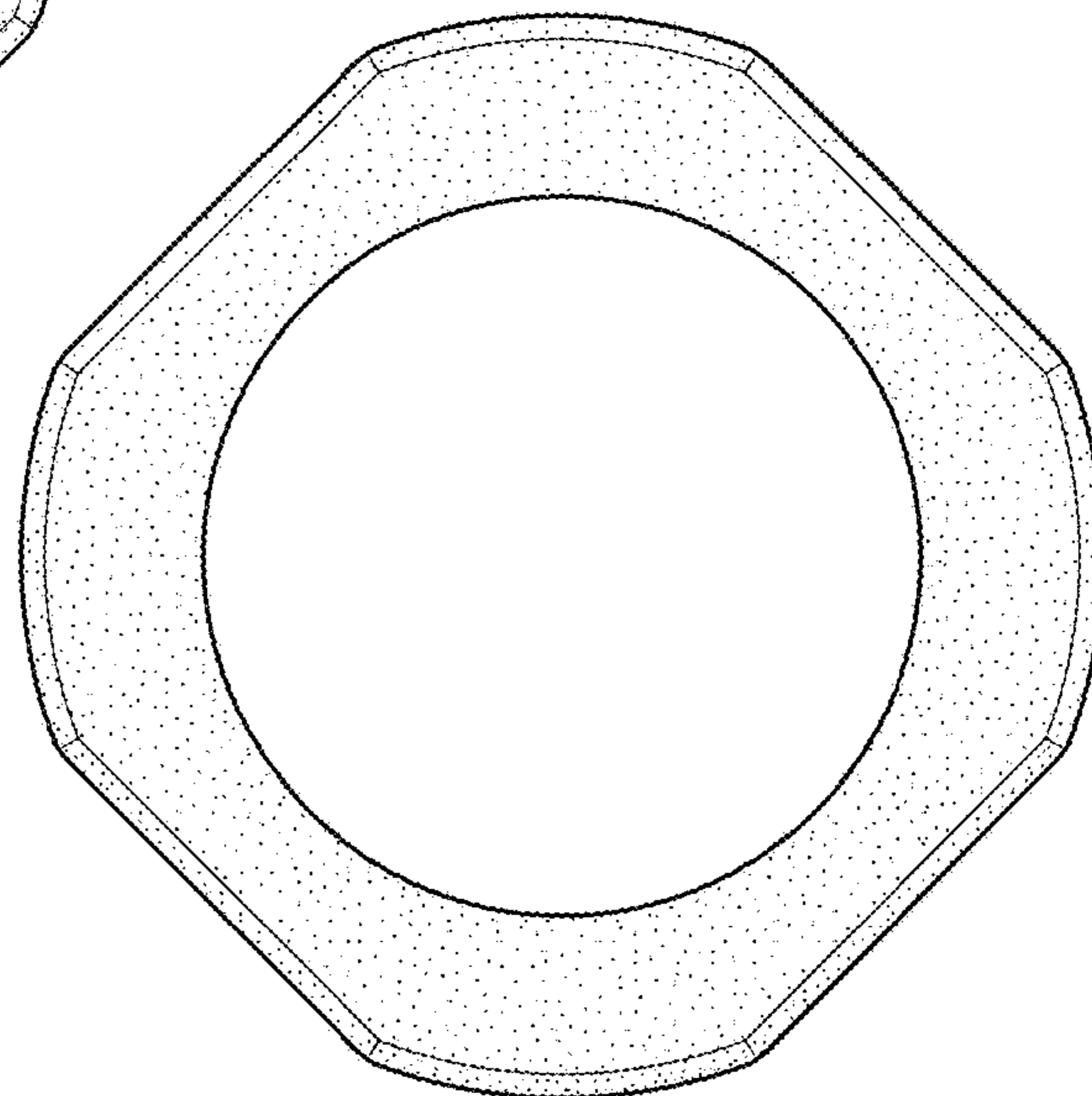

**FIG. 10**

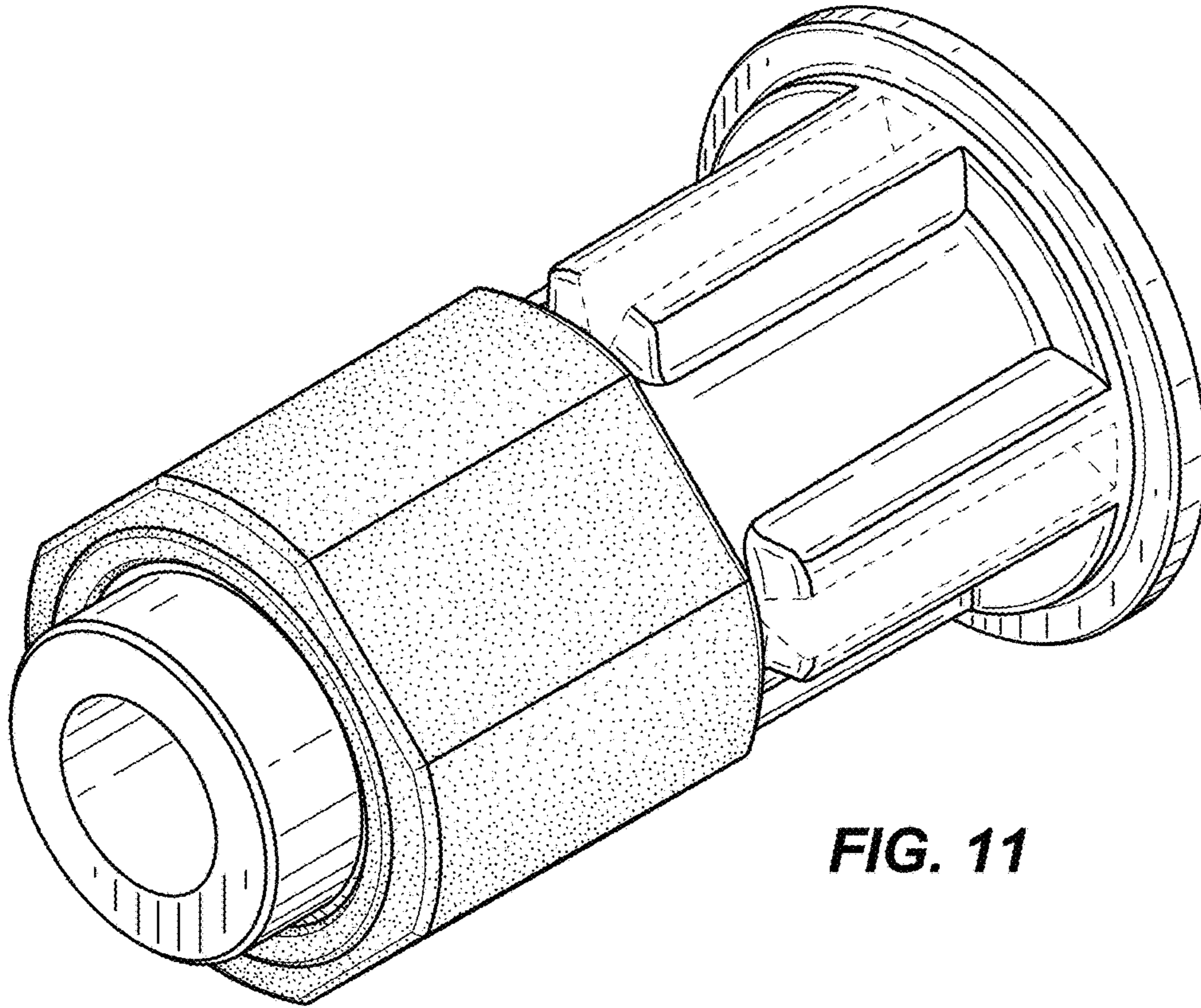

**FIG. 11**

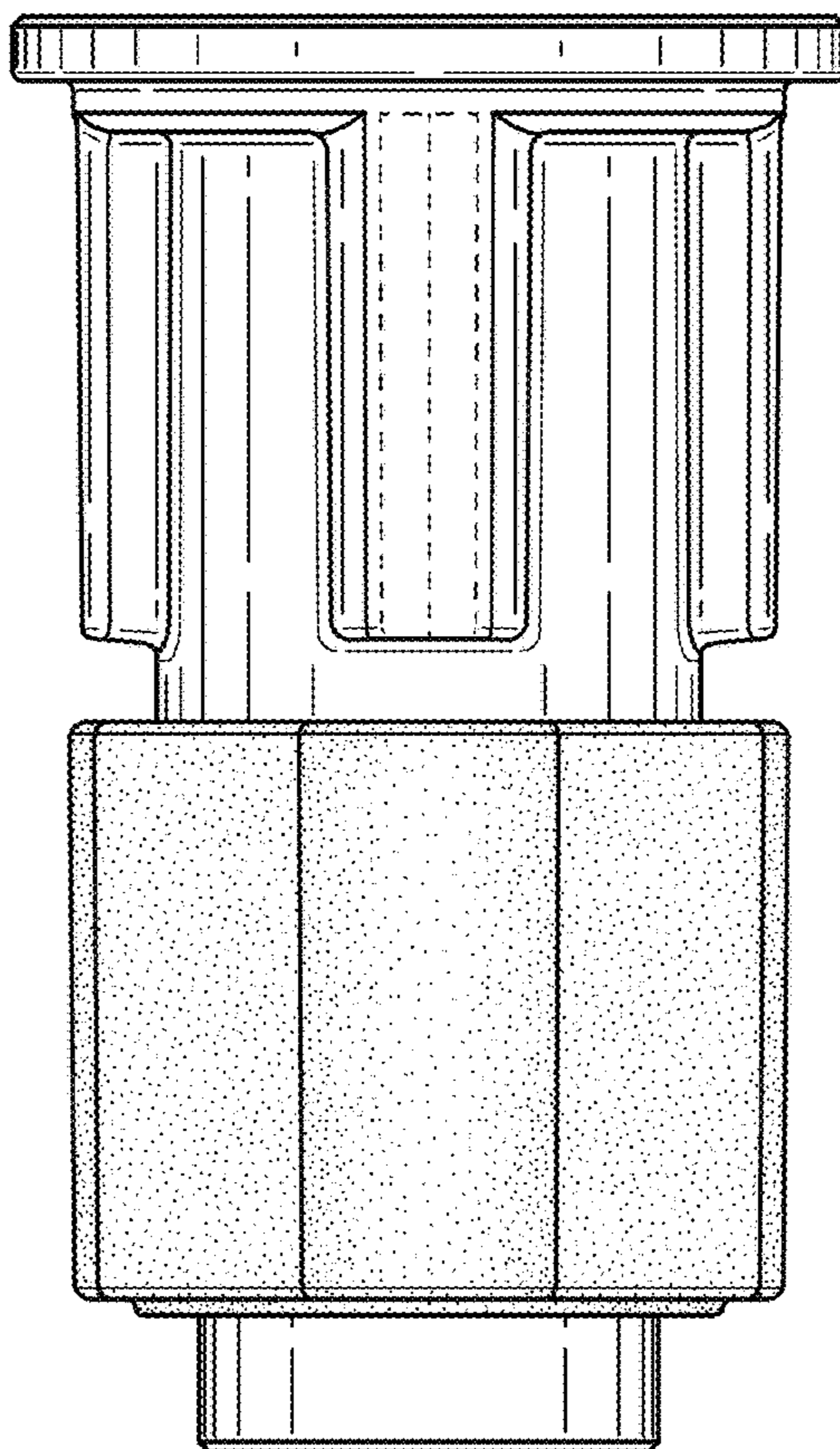

**FIG. 12**

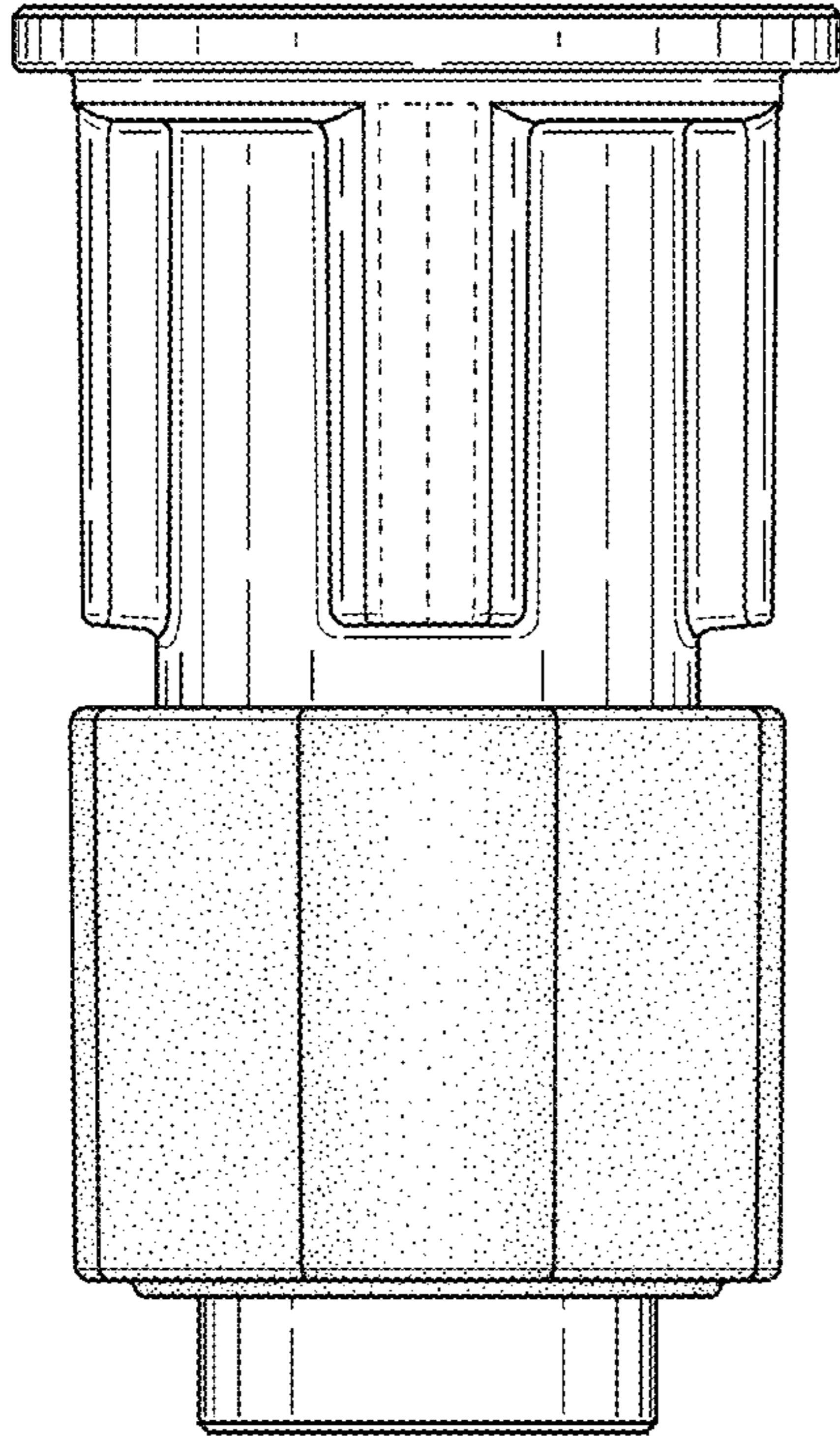

**FIG. 13**

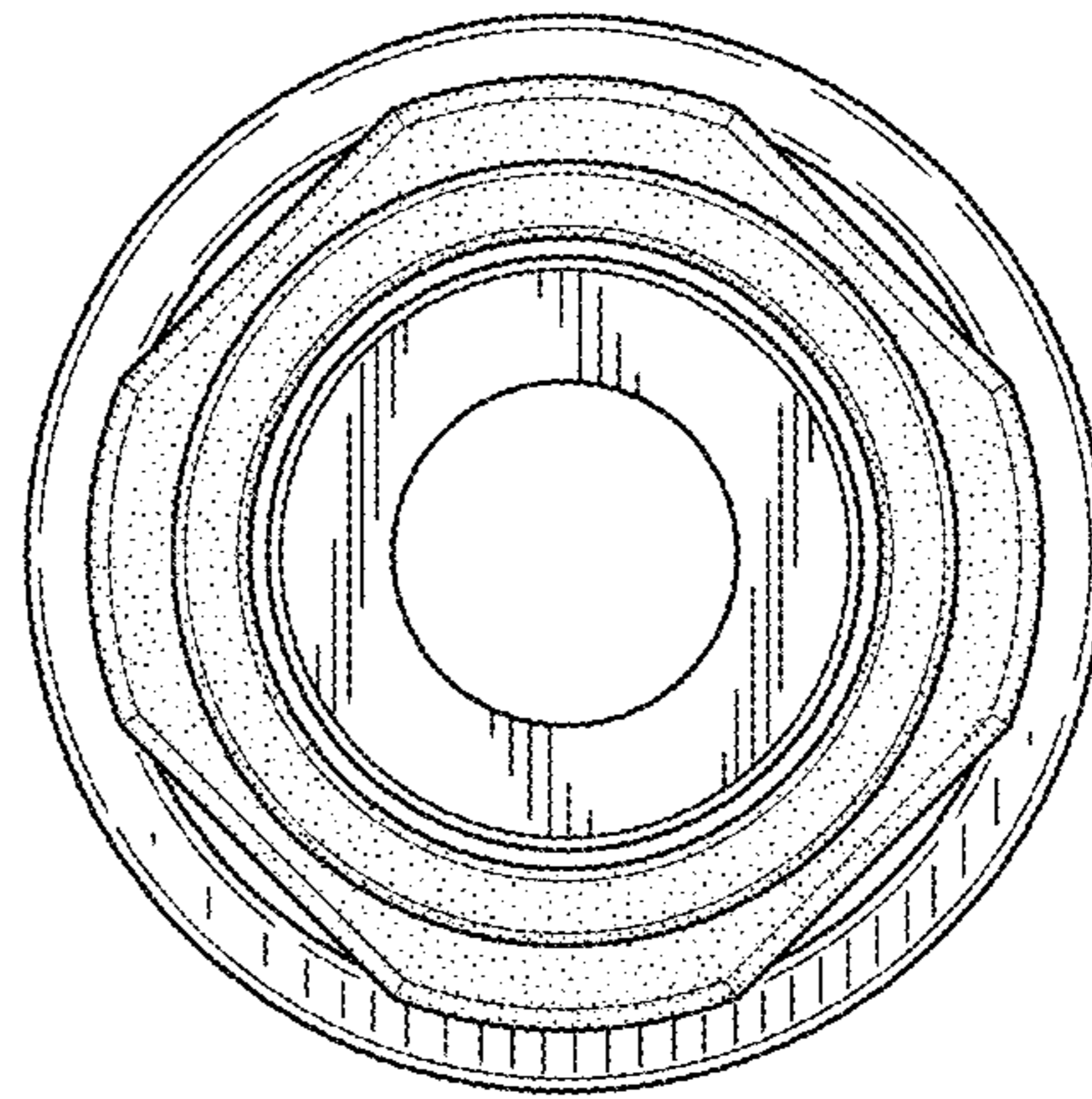

**FIG. 14**

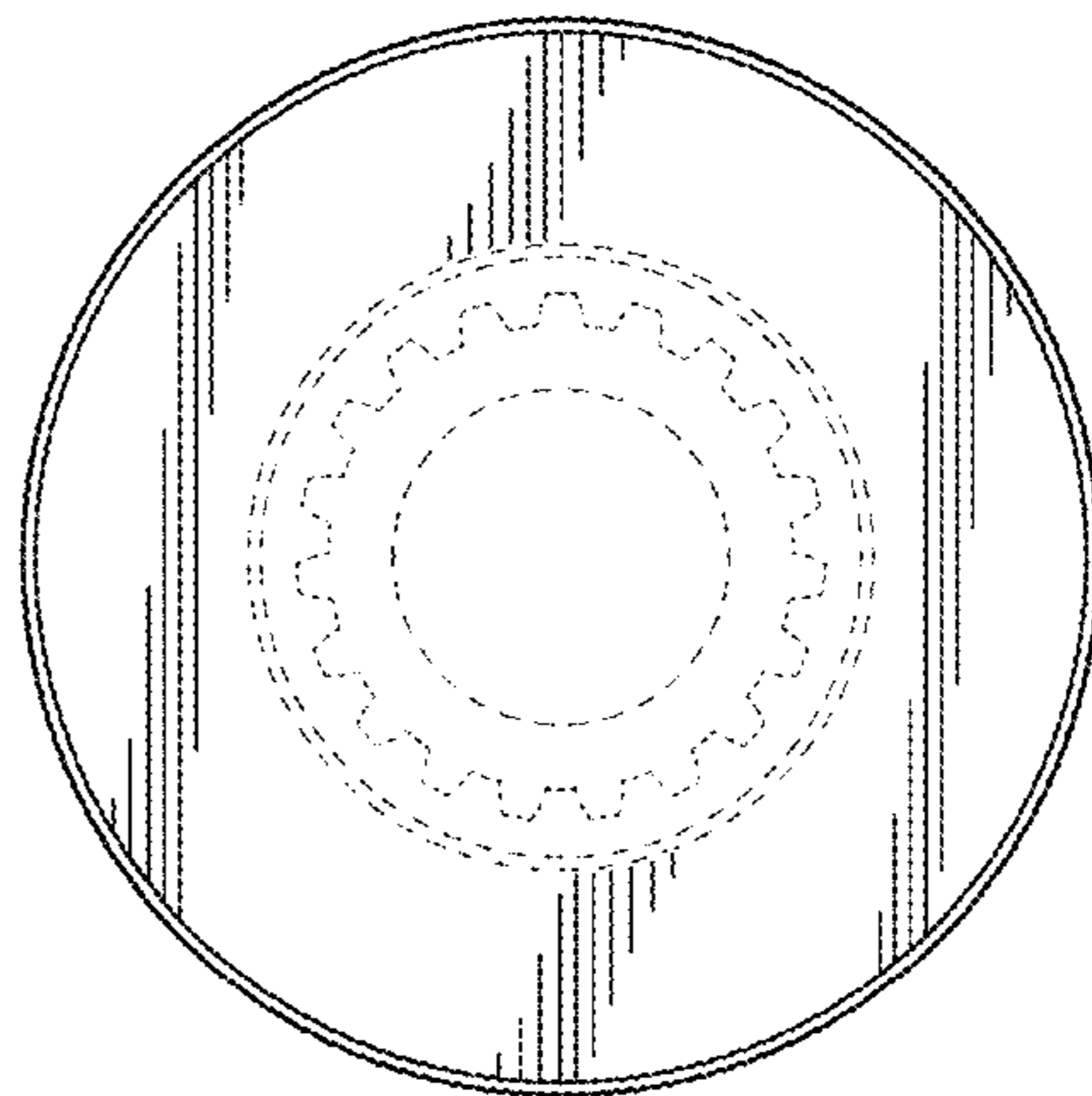

**FIG. 15**