



US00D807244S

(12) **United States Design Patent**
Kerr et al.

(10) **Patent No.:** **US D807,244 S**
(45) **Date of Patent:** **** Jan. 9, 2018**

(54) **FRONT END FOR A PASSENGER BUS**

CPC B62D 23/00; B62D 25/00; B62D 65/00;
B62D 53/062; B60D 2300/14

(71) Applicant: **New Flyer Industries Canada ULC,**
Winnipeg (CA)

See application file for complete search history.

(72) Inventors: **Andrew Kerr,** Winnipeg (CA); **Chris Watson,** Winnipeg (CA); **Ben Chao,** Winnipeg (CA); **Timothy Giesbrecht,** Winnipeg (CA); **Serge Carrier,** St-Jean-Chrysostome (CA)

(56) **References Cited**

U.S. PATENT DOCUMENTS

(73) Assignee: **NEW FLYER INDUSTRIES CANADA ULC,** Winnipeg, Manitoba (CA)

D254,609 S	4/1980	Neal et al.	
D255,340 S	6/1980	Flesche	
D257,141 S	9/1980	Flesche	
D376,562 S	12/1996	Sealy et al.	
D503,126 S	3/2005	Papke et al.	
D522,425 S	6/2006	Beigel et al.	
D589,420 S	3/2009	Raghavendran et al.	
D613,224 S	4/2010	Beigel et al.	
D627,696 S	11/2010	Yang et al.	
D637,520 S	5/2011	Kerr et al.	
D639,712 S	6/2011	Kerr et al.	
D642,092 S	7/2011	Wiens et al.	
D678,818 S *	3/2013	Kerr	D12/84
D774,942 S *	12/2016	Jing	D12/84
D774,944 S *	12/2016	Guo	D12/84

(**) Term: **15 Years**

(21) Appl. No.: **29/540,886**

(22) Filed: **Sep. 29, 2015**

Related U.S. Application Data

(63) Continuation of application No. 29/506,631, filed on Oct. 17, 2014, now Pat. No. Des. 742,289, which is a continuation of application No. 29/460,809, filed on Jul. 15, 2013, now Pat. No. Des. 723,442, which is a continuation-in-part of application No. 29/387,364, filed on Mar. 11, 2011, now Pat. No. Des. 687,593, which is a continuation-in-part of application No. 29/332,861, filed on Feb. 26, 2009, now Pat. No. Des. 639,712, and a continuation-in-part of application No. 29/331,953, filed on Feb. 5, 2009, now Pat. No. Des. 637,520, said application No. 29/460,809 is a continuation-in-part of application No. 29/386,426, filed on Mar. 1, 2011, now Pat. No. Des. 692,360.

* cited by examiner

Primary Examiner — Melody N Brown

(74) *Attorney, Agent, or Firm* — Dickinson Wright LLP

(51) **LOC (11) Cl.** **12-08**

(52) **U.S. Cl.**
USPC **D12/164**; D12/84

(57) **CLAIM**

We claim the ornamental design for a front end for a passenger bus, as shown and described.

(58) **Field of Classification Search**
USPC D12/82, 84, 164; 296/178

DESCRIPTION

FIG. 1 is a top, front and right side perspective view of a front end of a passenger bus showing our new design; FIG. 2 is a top plan view thereof; FIG. 3 is a right side elevational view thereof; and, FIG. 4 is a front elevational view thereof. The environmental structures shown in broken lines throughout the drawings are for illustrative purposes only and form no part of the claimed design.

1 Claim, 2 Drawing Sheets

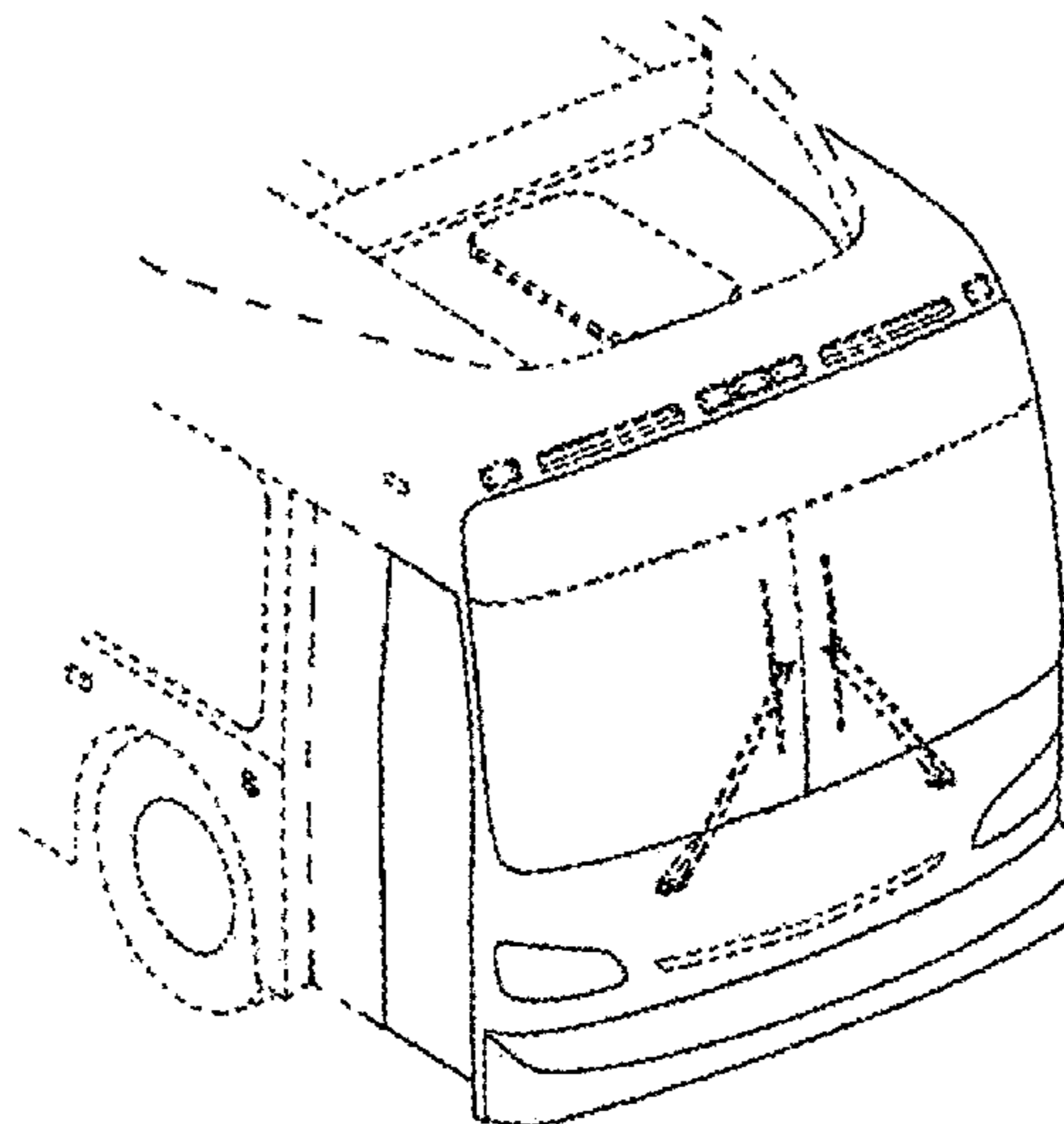

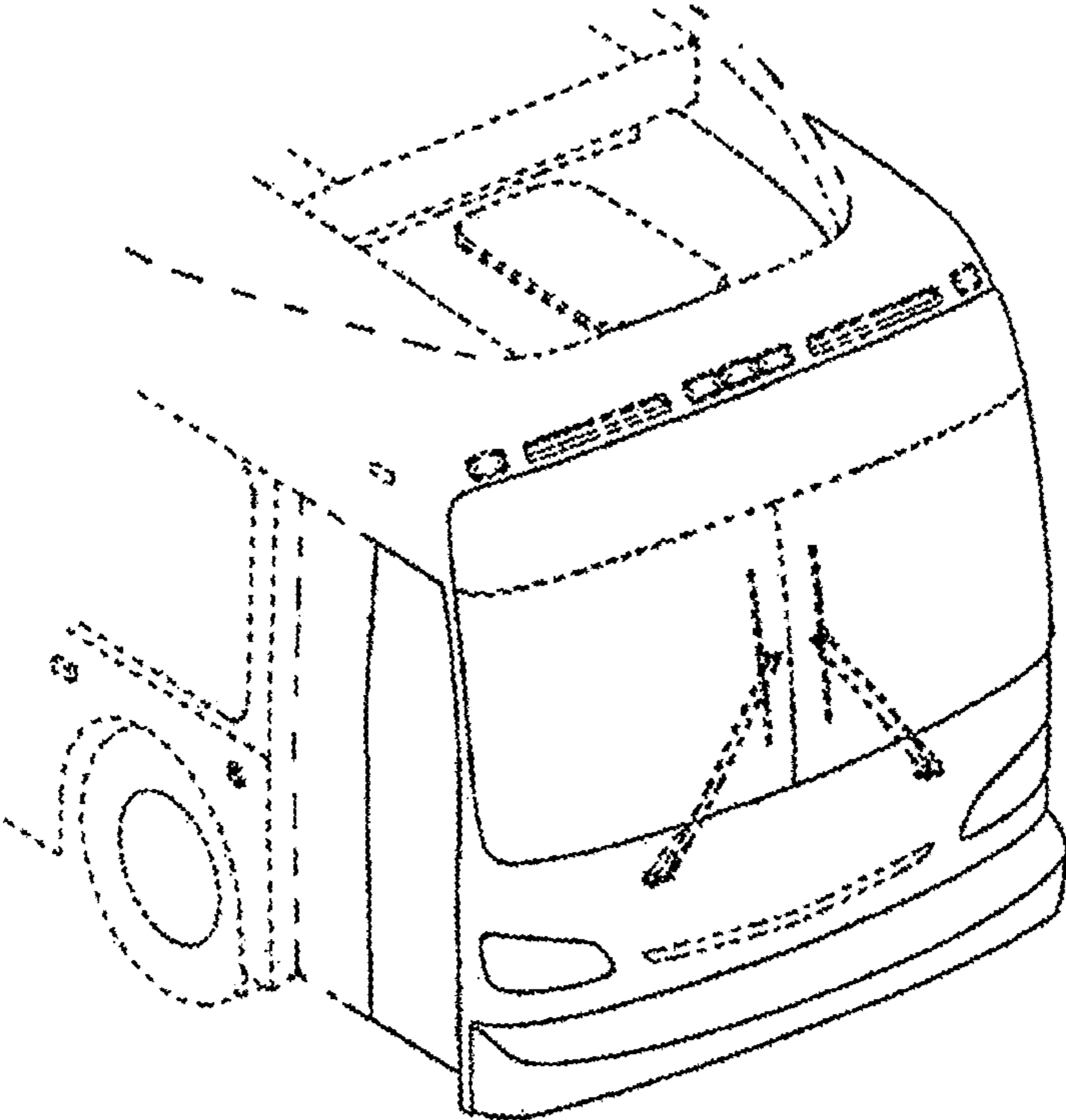

FIG. 1

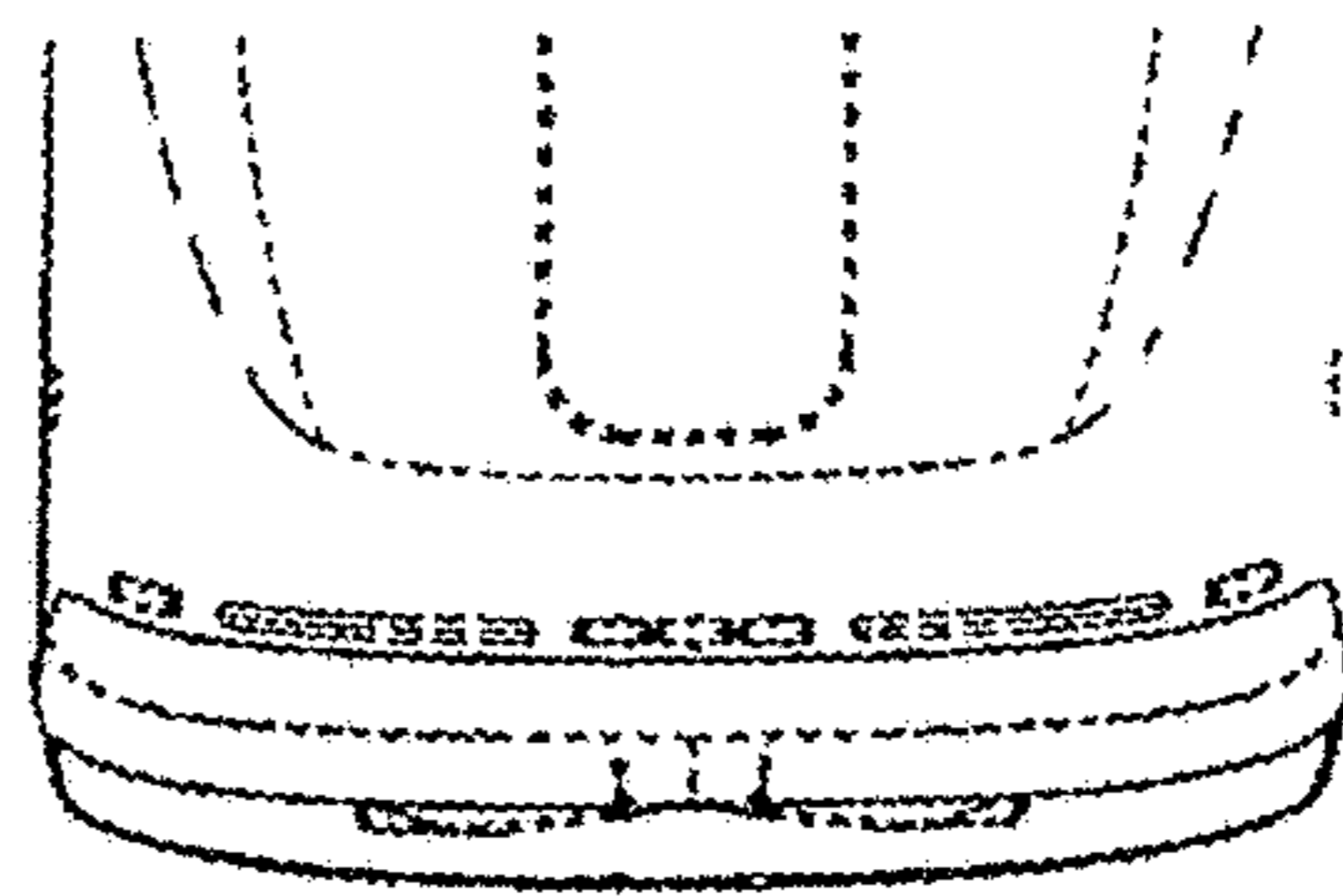

FIG. 2

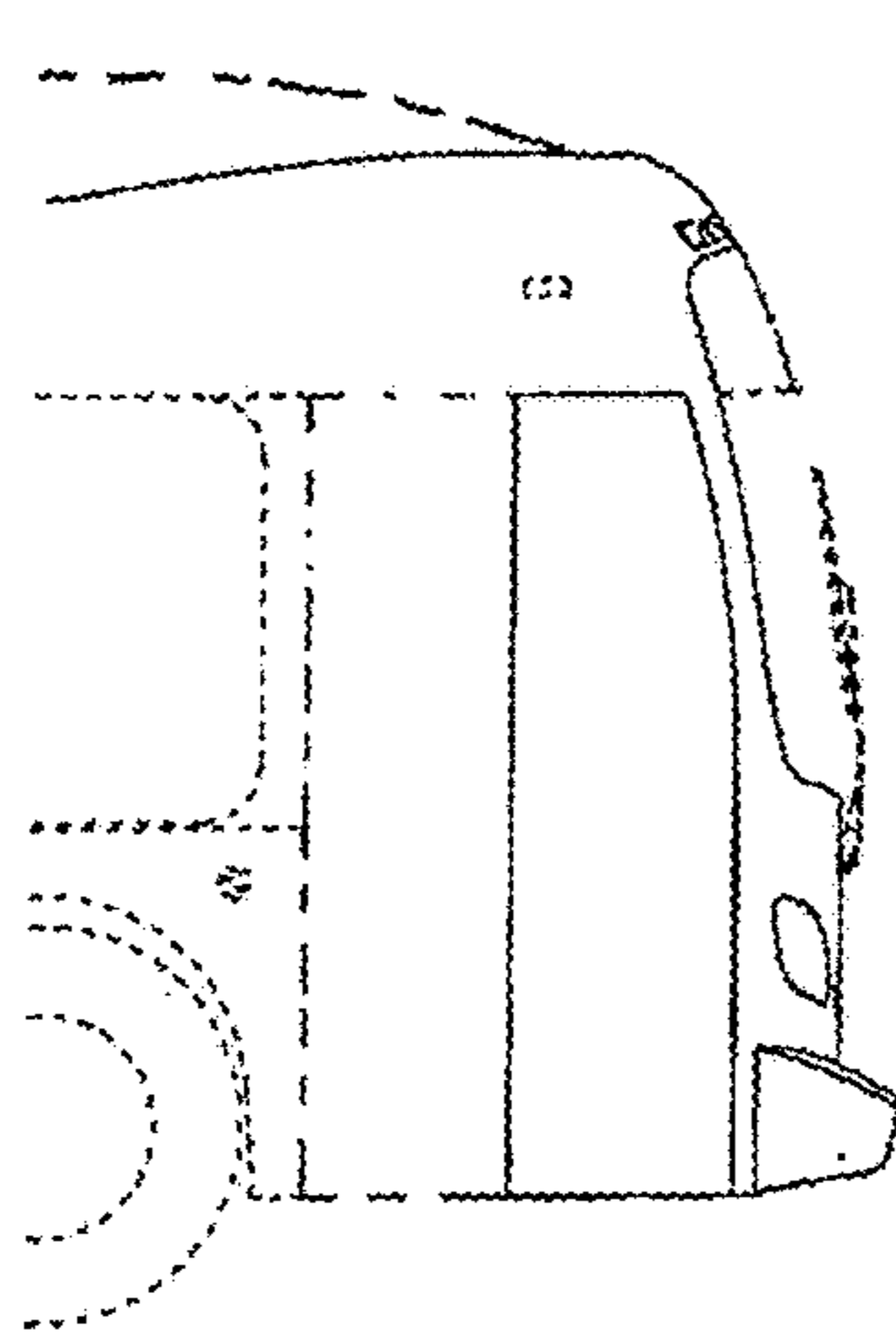

FIG. 3

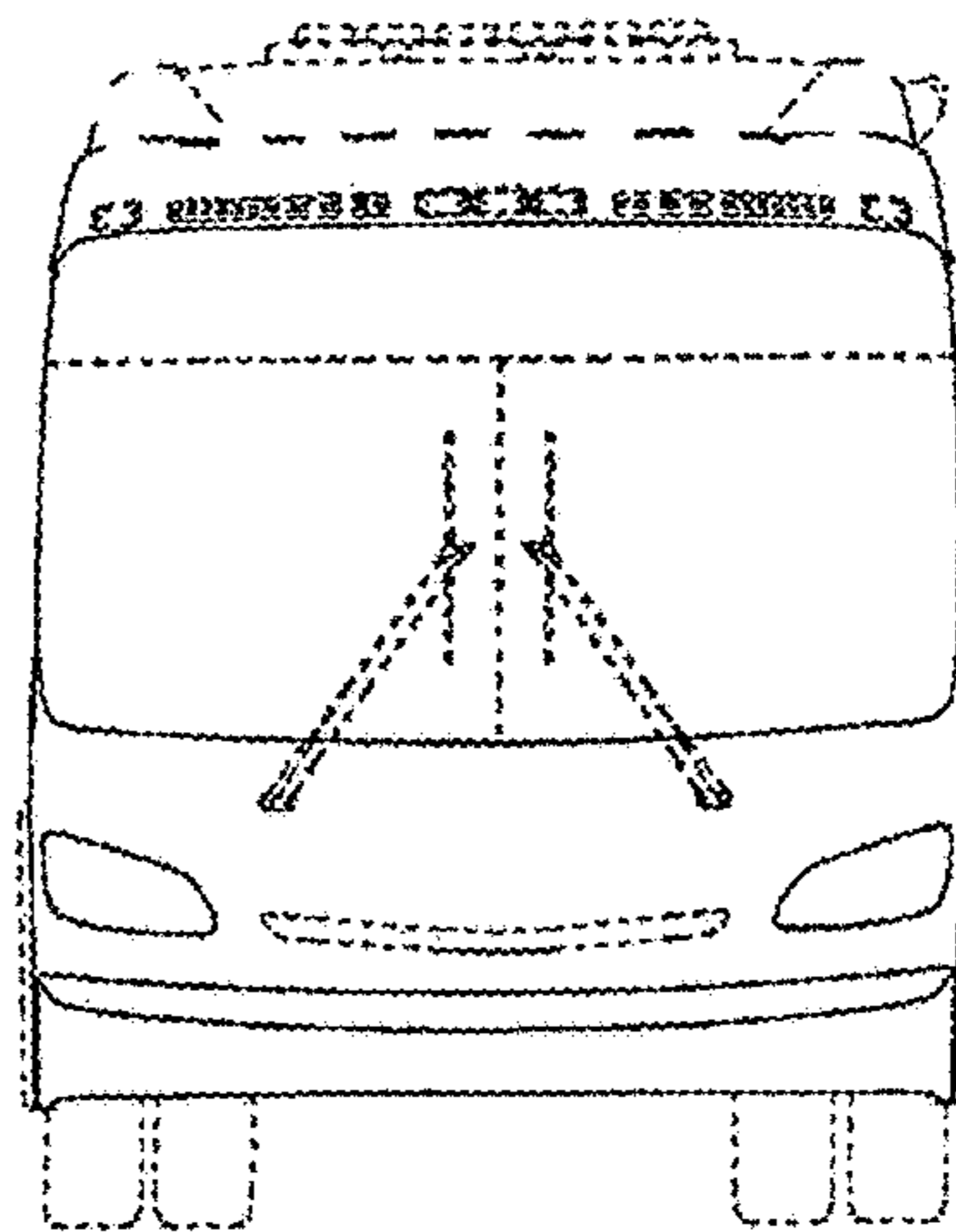

FIG. 4