



US00D807228S

(12) **United States Design Patent**  
**Woolley**

(10) **Patent No.:** **US D807,228 S**  
(45) **Date of Patent:** **\*\* Jan. 9, 2018**

- (54) **FRONT END OF A VEHICLE**
- (71) Applicant: **Jaguar Land Rover Limited**, Whitley, Coventry (GB)
- (72) Inventor: **Richard Woolley**, Coventry (GB)
- (73) Assignee: **Jaguar Land Rover Limited**, Whitley, Coventry (GB)

(\*\*) Term: **15 Years**

(21) Appl. No.: **29/555,905**

(22) Filed: **Feb. 25, 2016**

(30) **Foreign Application Priority Data**

Sep. 4, 2015 (EM) ..... 002766667

(51) **LOC (11) Cl.** ..... **12-08**

(52) **U.S. Cl.**  
USPC ..... **D12/91**

(58) **Field of Classification Search**  
USPC ..... D12/90-92, 164, 169, 196; D21/548, D21/560; 296/181.1, 181.5  
CPC ..... B60Y 2306/01; B60K 11/085  
See application file for complete search history.

(56) **References Cited**

**U.S. PATENT DOCUMENTS**

- D559,754 S \* 1/2008 Murkett ..... D12/164
- D684,094 S \* 6/2013 Le Grice ..... D12/91
- D697,840 S \* 1/2014 Kwon ..... D12/164
- D703,584 S \* 4/2014 Futschik ..... D12/92

- D716,695 S \* 11/2014 Woolley ..... D12/91
- D725,556 S \* 3/2015 Barnes ..... D12/163
- D729,706 S \* 5/2015 Burki ..... D12/164
- D730,253 S \* 5/2015 Burki ..... D12/164
- D735,610 S \* 8/2015 Wheel ..... D12/91
- D749,996 S \* 2/2016 Henstridge ..... D12/164
- D750,532 S \* 3/2016 Frascella ..... D12/91
- D774,417 S \* 12/2016 Watkins ..... D12/91
- D786,747 S \* 5/2017 Woolley ..... D12/169

\* cited by examiner

*Primary Examiner* — John Windmuller

*Assistant Examiner* — Melvin L Davis

(74) *Attorney, Agent, or Firm* — Wood Herron & Evans LLP

(57) **CLAIM**

The ornamental design for a front end of a vehicle, as shown and described.

**DESCRIPTION**

FIG. 1 is a right front perspective view of a front end of a vehicle;

FIG. 2 is a left rear perspective view of the vehicle shown in FIG. 1.

FIG. 3 is a front view thereof.

FIG. 4 is a left side view thereof.

FIG. 5 is a right side view thereof; and,

FIG. 6 is a top view thereof.

The vehicle is shown in de-emphasized and half-tone portions so as to illustrate environmental structures for the rear end. These portions form no part of the claimed invention. Parts of the claimed design demarcated by broken lines form no part of the claimed invention.

**1 Claim, 5 Drawing Sheets**

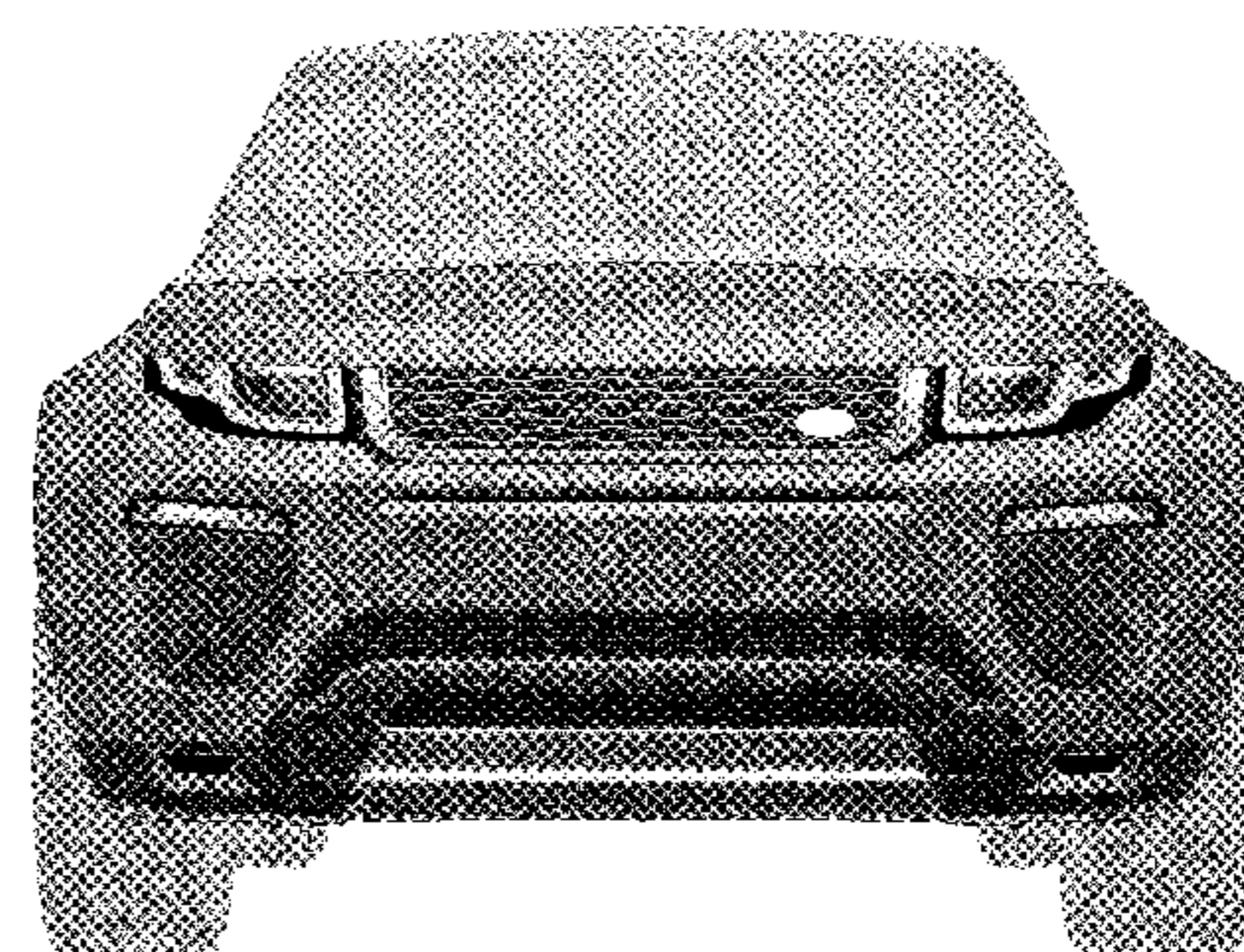
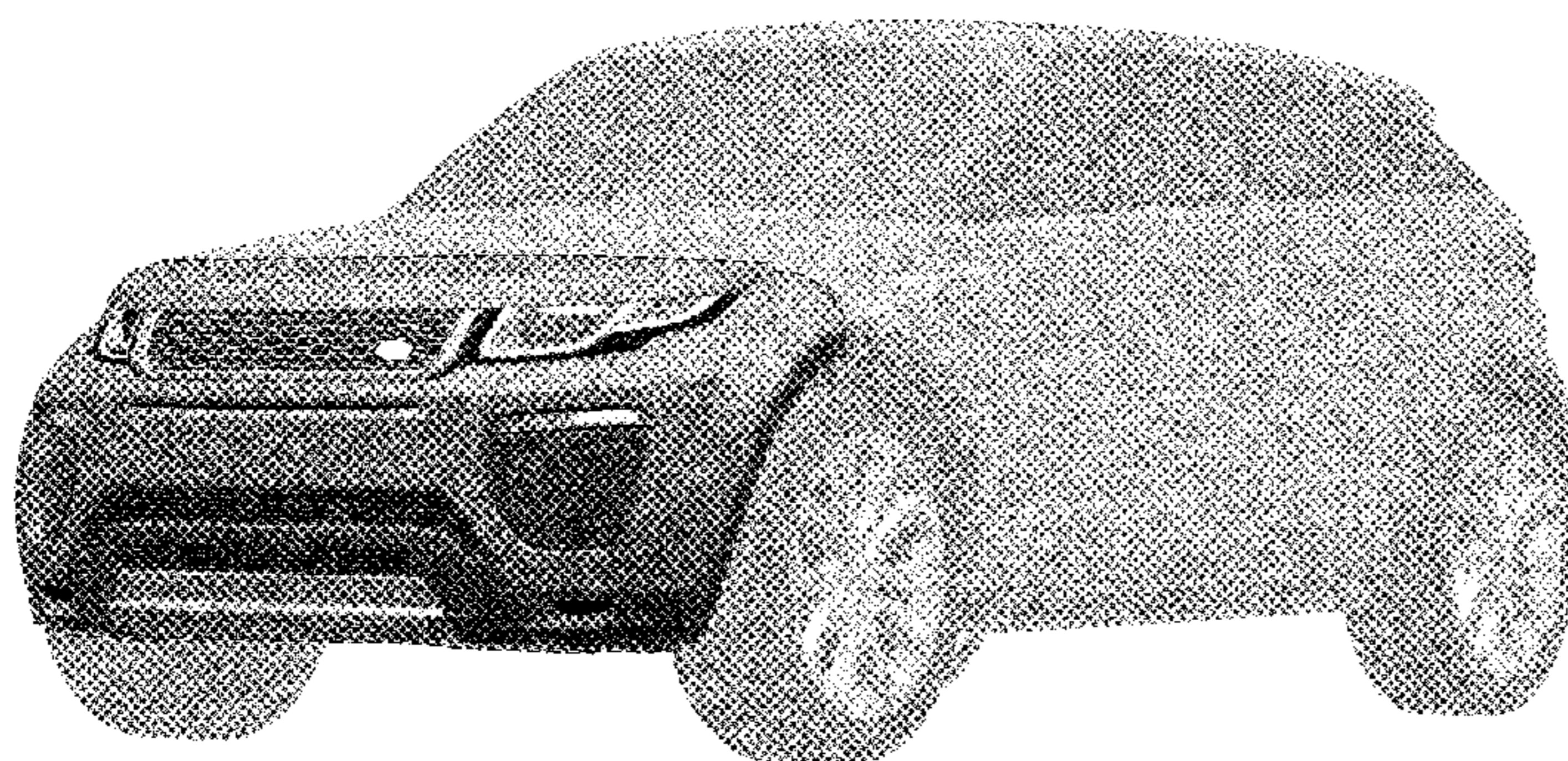



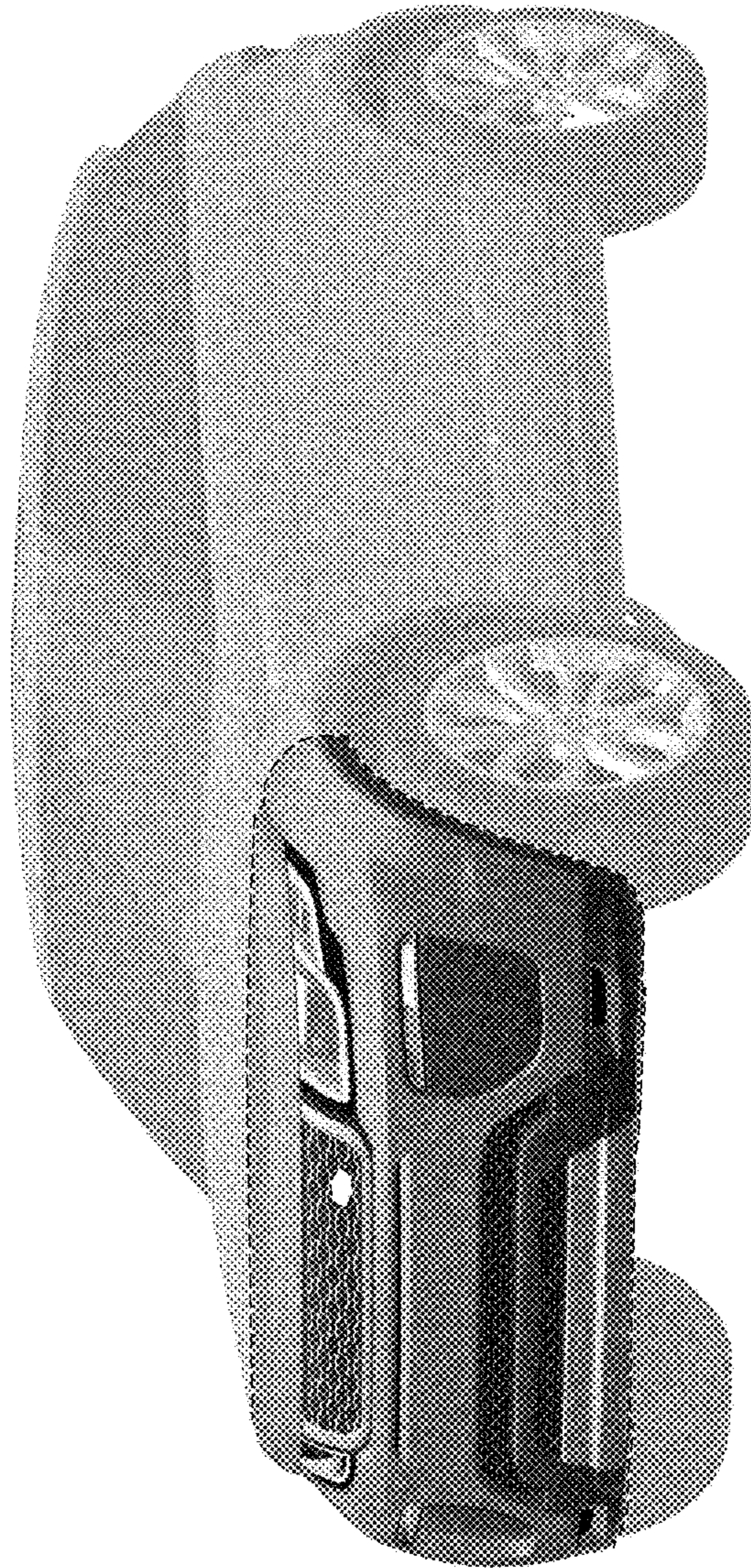

FIG. 1



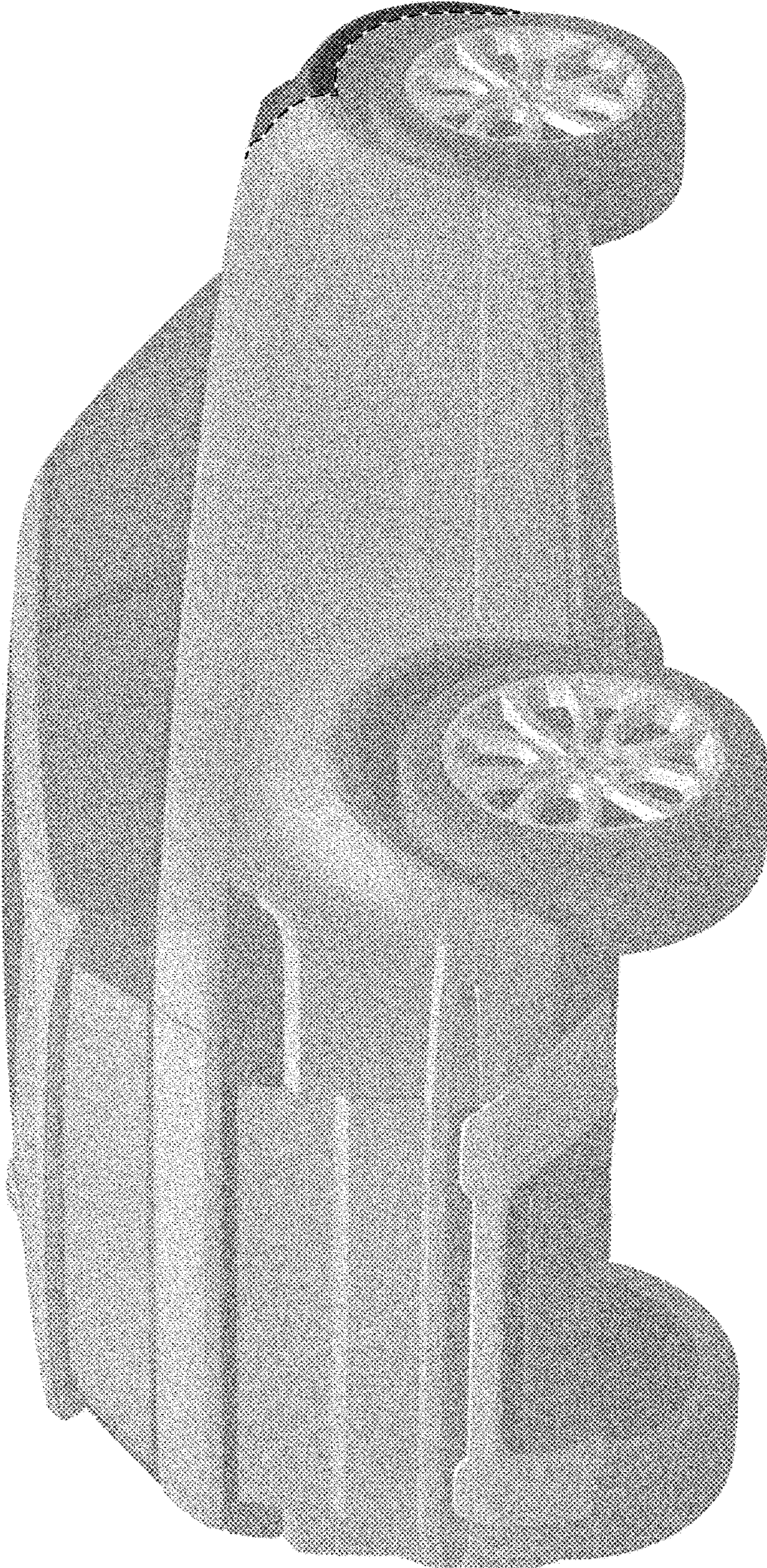

FIG. 2



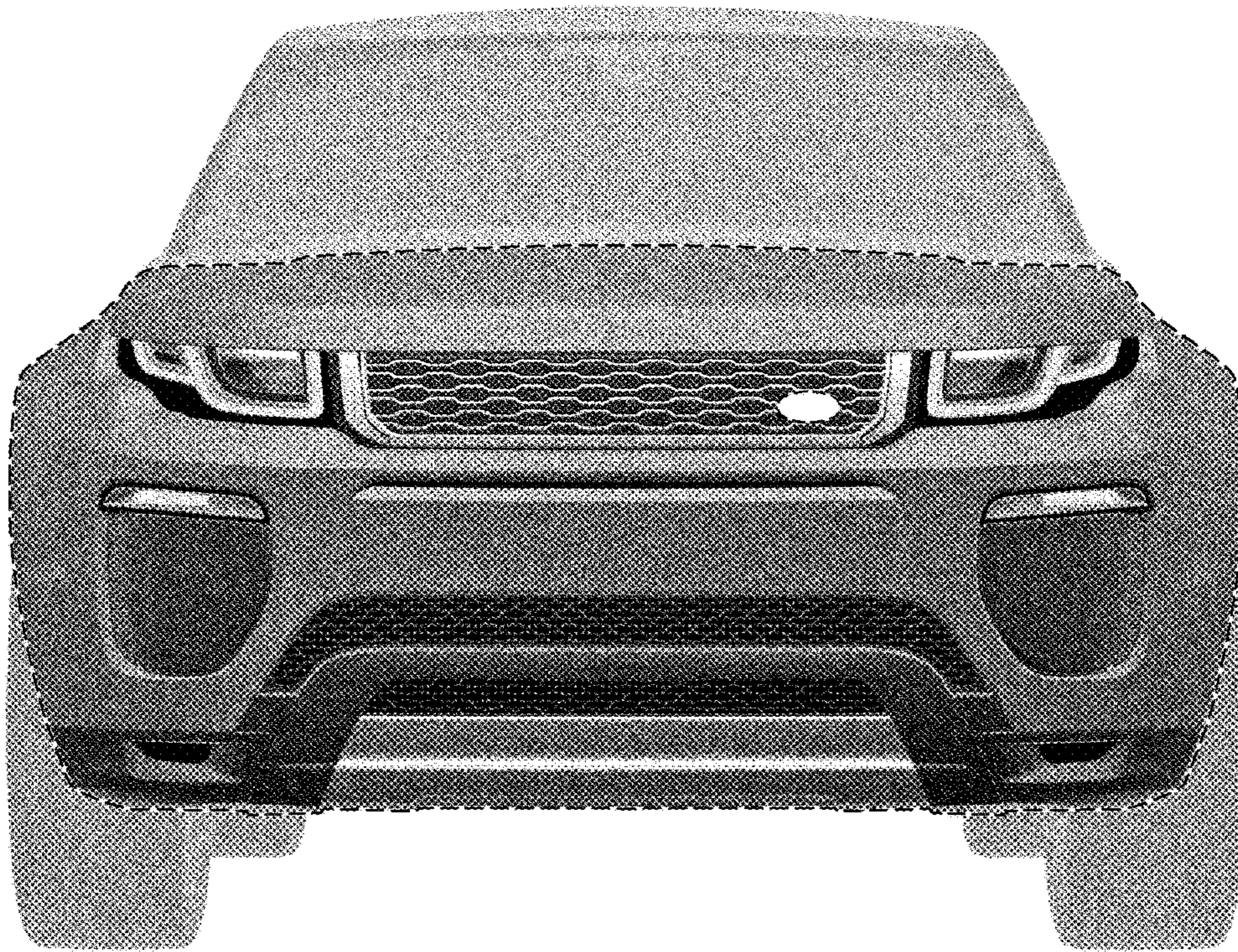

FIG. 3



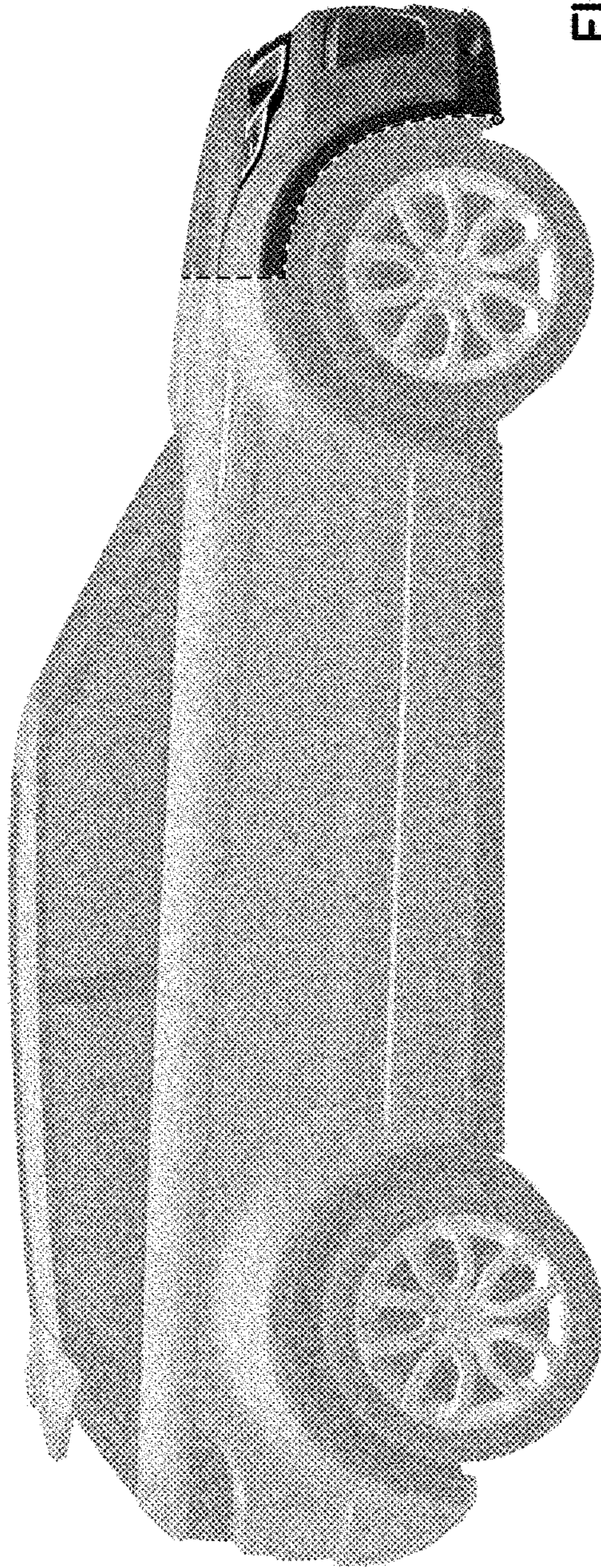

FIG. 4

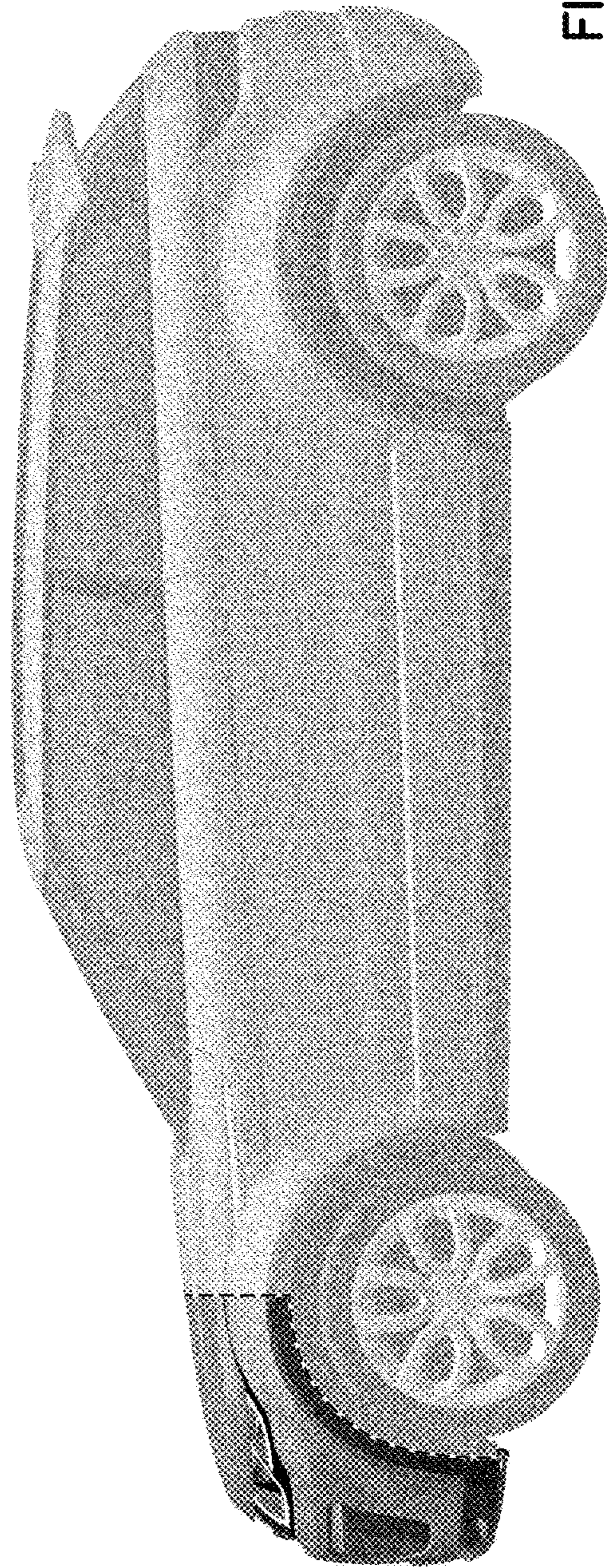

FIG. 5



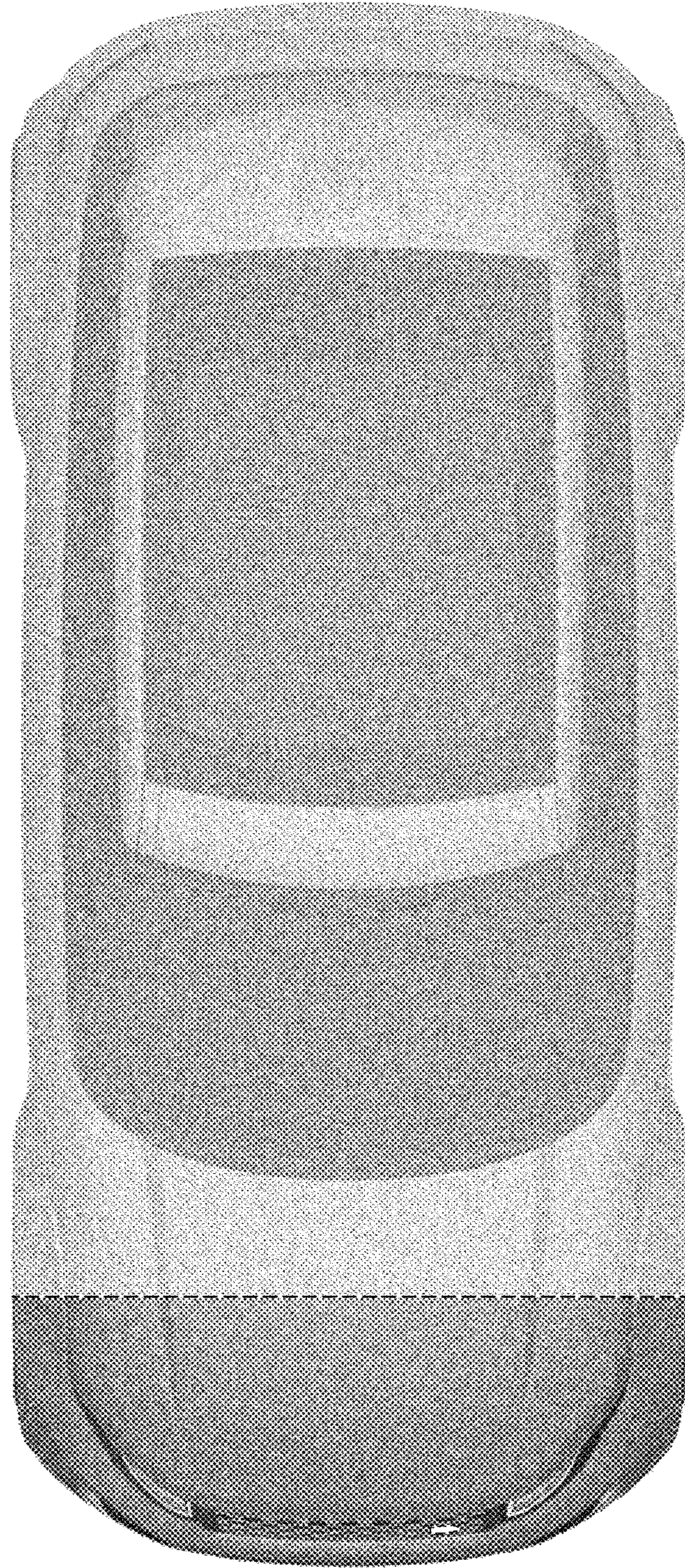

FIG. 6