



US00D807153S

(12) **United States Design Patent**
Templeman et al.

(10) **Patent No.:** **US D807,153 S**
(45) **Date of Patent:** **** Jan. 9, 2018**

(54) **EXTRUDED STICKER FOR SPACING WOOD**

FOREIGN PATENT DOCUMENTS

(71) Applicant: **DSV Holdings, LLC**, Osage Beach, MO (US)

WO 2009105253 A2 8/2009

(72) Inventors: **Steven W. Templeman**, Lake Ozark, MO (US); **Scott W. Templeman**, Carthage, MO (US)

OTHER PUBLICATIONS

(73) Assignee: **DSV Holdings LLC**, Osage Beach, MO (US)

An experimental study of the characteristics of fluid flow and heat transfer in the multiport microchannel flat tube, posted Apr. 2014, [retrieved Mar. 2, 2017]. Retrieved from Internet, <URL: https://reginnovations.org/key-scientific-articles/experimental-study-characteristics-fluid-flow-heat-transfer-multiport-microchannel-flat-tube/ >.*

(**) Term: **15 Years**

(Continued)

(21) Appl. No.: **29/568,188**

(22) Filed: **Jun. 16, 2016**

Primary Examiner — Barbara Fox

Assistant Examiner — Kristin E Reed

(51) **LOC (11) Cl.** **08-05**

(74) *Attorney, Agent, or Firm* — Martin & Associates, LLC; Derek P. Martin

(52) **U.S. Cl.**
USPC **D8/354**

(58) **Field of Classification Search**
USPC D8/48, 71, 315–322, 354–355, 378–381, D8/400–499; D12/420, 223; D25/119–125, 199

CPC F16L 1/00; F16L 9/00; F16L 13/00; B25H 3/04; A61B 1/00; A61B 17/00; A61B 2217/00; A61B 2218/00; H02G 1/00; H02G 2200/00; A47F 1/00; H02J 1/00

See application file for complete search history.

(57) **CLAIM**

The ornamental design for an extruded sticker for spacing wood, as shown and described.

DESCRIPTION

FIG. 1 is an end view of the extruded sticker for spacing wood showing the new design, with the opposing end view being identical;

FIG. 2 is a top view thereof, with the opposing bottom view being identical;

FIG. 3 is a side view thereof, with the opposing side view being identical; and,

FIG. 4 is a perspective view thereof, with the broken line not forming part of the claimed design.

The extruded sticker for spacing wood is shown with a symbolic break in its length. The appearance of any portion of the article between the break lines forms no part of the claimed design.

(56) **References Cited**

U.S. PATENT DOCUMENTS

D19,126 S *	6/1889	Bell	D23/386
1,274,306 A *	7/1918	Moisson	D06F 57/10
				211/132.1
D216,014 S *	11/1969	Dupont	D22/110
3,686,817 A *	8/1972	Adams	F16B 5/0052
				52/438
3,900,957 A	8/1975	Denton et al.		
4,059,914 A *	11/1977	Dobson	G09F 15/0006
				248/251
4,199,870 A	4/1980	Arsenault		
4,660,727 A *	4/1987	Levine	A47B 73/006
				211/74

(Continued)

1 Claim, 2 Drawing Sheets

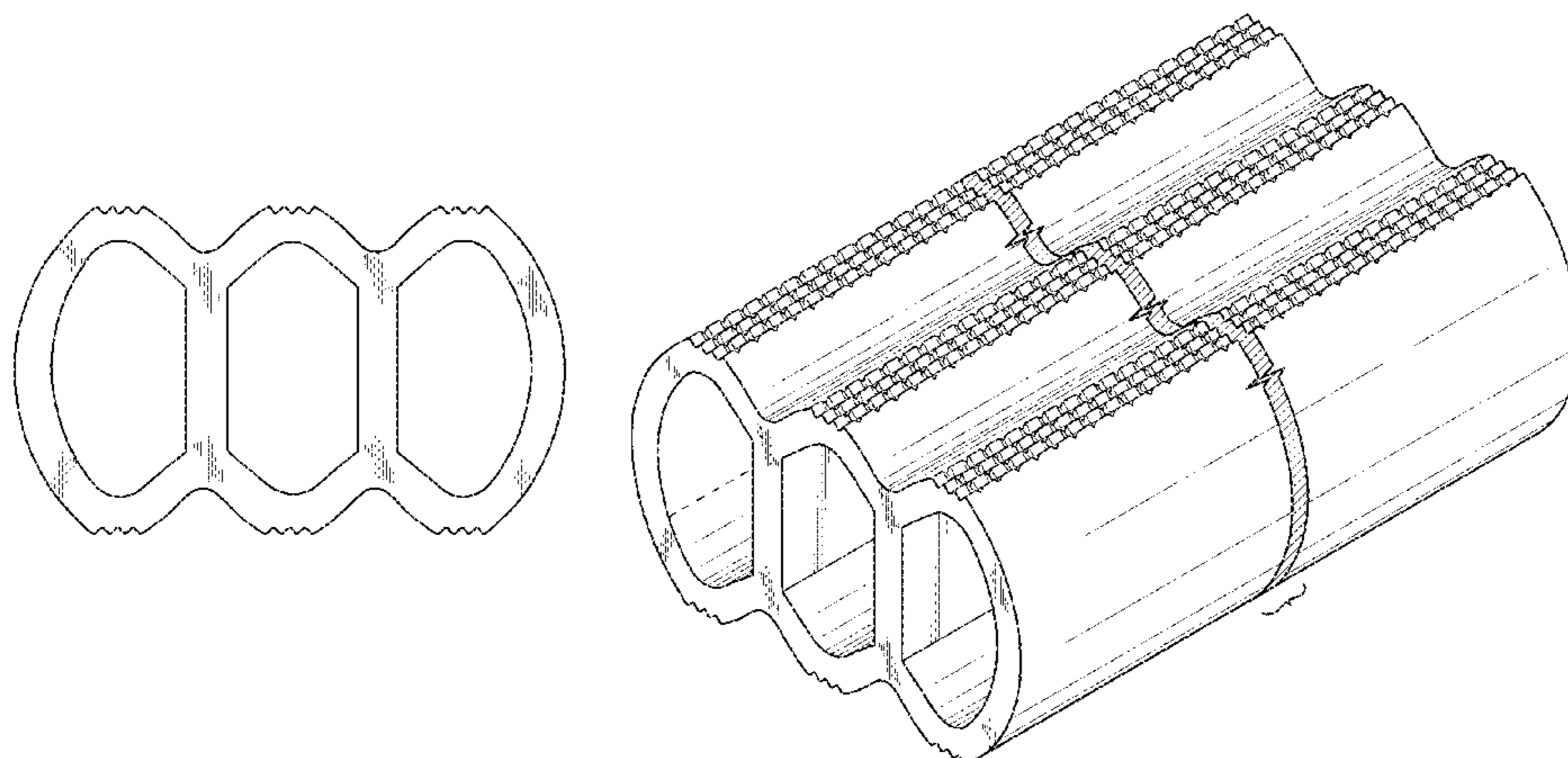

(56)

References Cited

U.S. PATENT DOCUMENTS

D289,587 S * 5/1987 Levine D6/682.2
 4,663,860 A 5/1987 Beall
 4,788,777 A 12/1988 Davis
 5,131,559 A * 7/1992 Ariyoshi B65D 1/24
 220/507
 D343,350 S * 1/1994 Gold D8/354
 5,345,695 A 9/1994 Graham
 D372,539 S * 8/1996 Davies D25/119
 5,813,137 A 9/1998 Townsend
 6,134,803 A 10/2000 Gilchrist et al.
 D451,612 S * 12/2001 Thibault D25/119
 6,435,355 B1 * 8/2002 Brown A47B 73/006
 211/44
 6,517,926 B1 2/2003 Therrien et al.
 RE38,118 E 5/2003 Townsend
 D488,964 S * 4/2004 Dagan D7/701
 7,003,898 B2 2/2006 Aaron
 D538,219 S * 3/2007 Rakow D12/414
 D569,655 S * 5/2008 Williams D6/682.2
 D577,269 S * 9/2008 Ropek D7/703
 D588,880 S * 3/2009 Chou D7/701
 7,926,199 B2 4/2011 Aaron
 D664,921 S * 8/2012 Stone D13/110

D689,206 S * 9/2013 Ellsworth D25/125
 9,121,177 B1 * 9/2015 Sorkin E04C 5/20
 D744,666 S * 12/2015 Weber D25/119
 D796,344 S * 9/2017 Paulick D25/115
 2016/0370114 A1 * 12/2016 Templeman F26B 25/185

OTHER PUBLICATIONS

Brown, Lawrence D., "Dry Kiln Sticker Repair Costs and Procedures", 15th Meeting of the Western Dry Kiln Clubs, 1963.
 Denig et al, "Drying Hardwood Lumber", USDA Forest Service Forest Products Laboratory General Technical Report FPL-GTR-118, 2000.
 Rash, James K., "Engineered Kiln Stickers—A New Way to Save Costs", Chemicals Division Simpson Timber Company, Portland, Oregon, 1973.
 Peabody et al., "Plastic Stickers for the Kiln Drying Operation", Portland Industrial Plastics Company, 1971.
 Teesdale, L.V., "The Kiln Drying of Southern Yellow Pine Lumber", US Dept. of Agriculture, Jan. 1930.
 Hendess et al., "Pipe and Tubing Extrusion", The SPE Guide on Extrusion Technology and Troubleshooting, Society of Plastics Engineers, 2001.

* cited by examiner

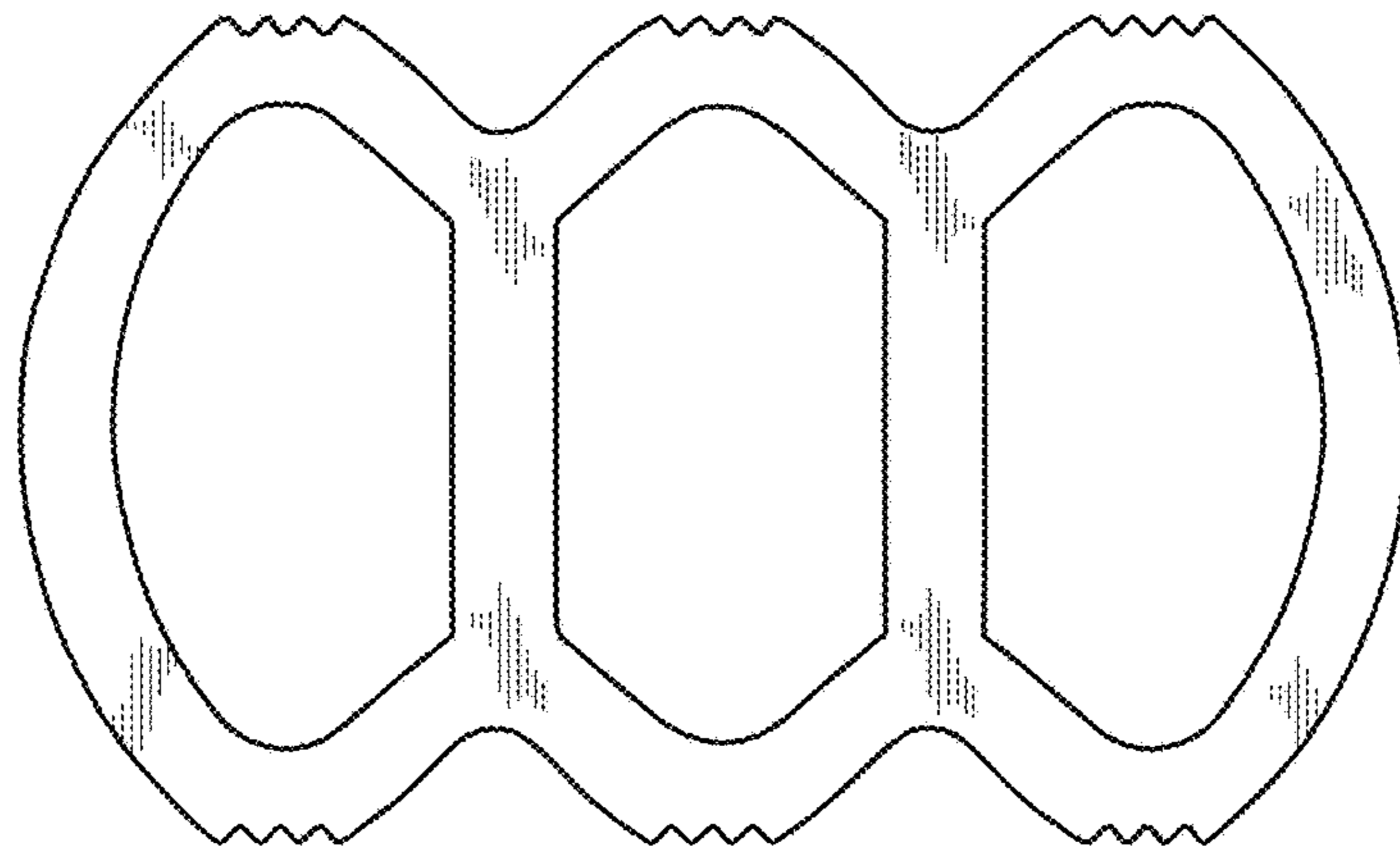

FIG. 1

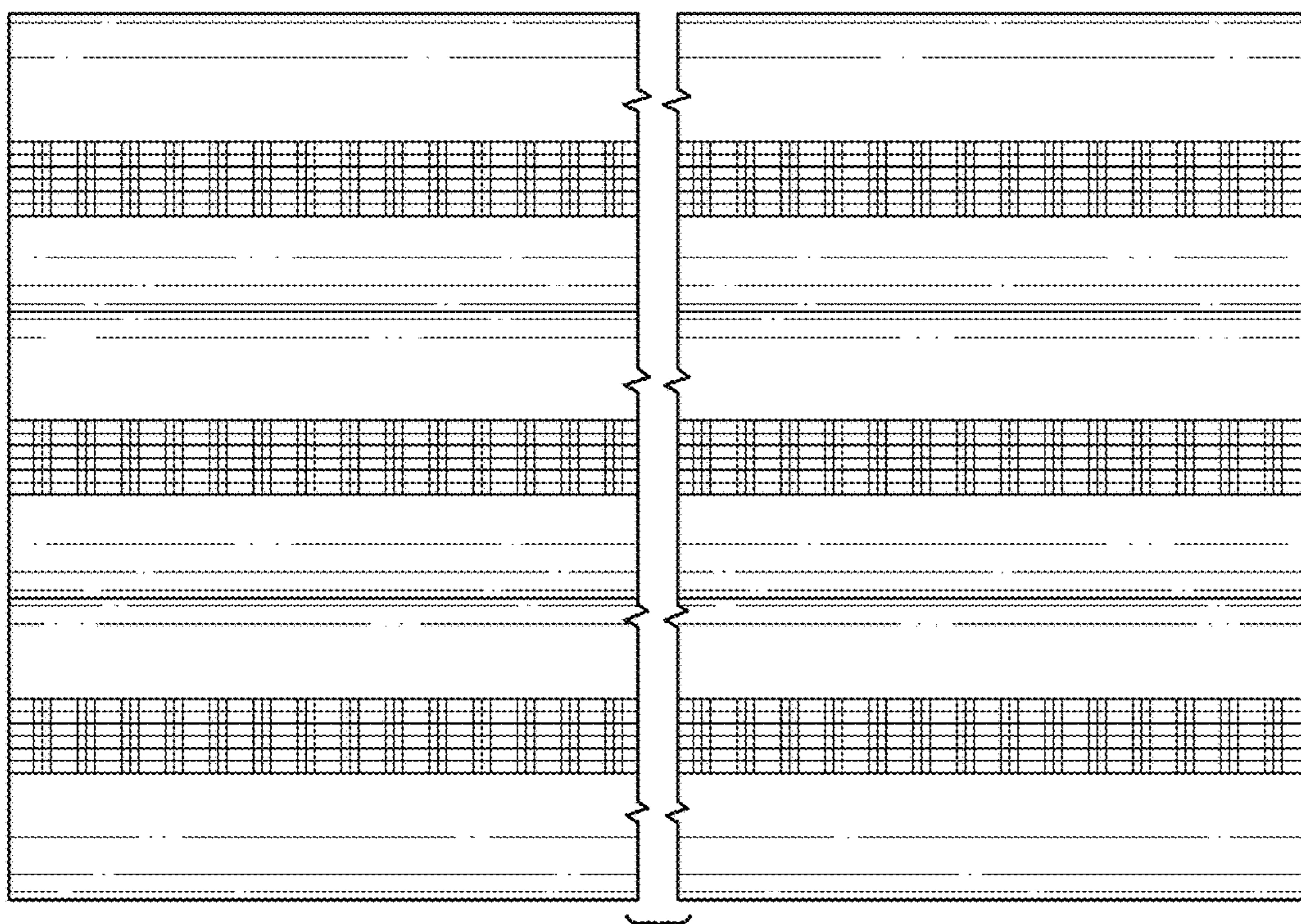

FIG. 2

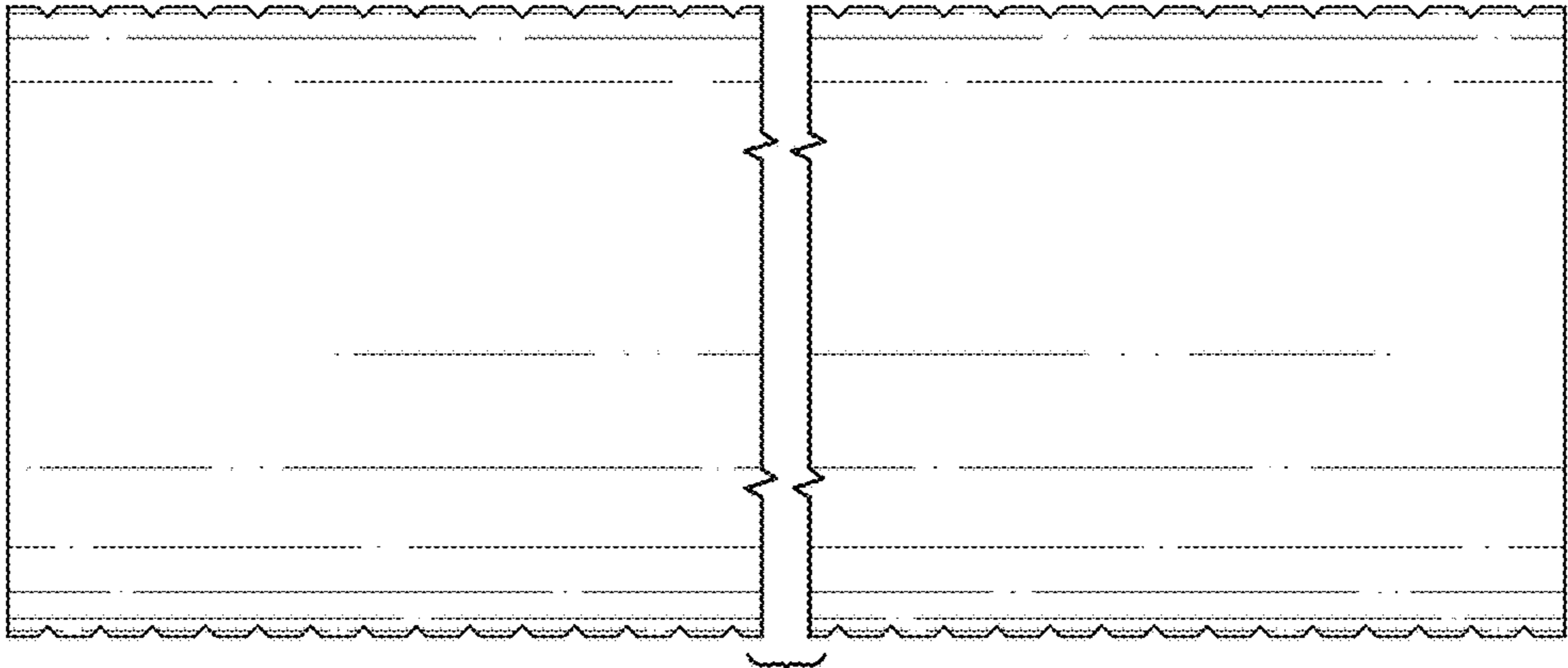

FIG. 3

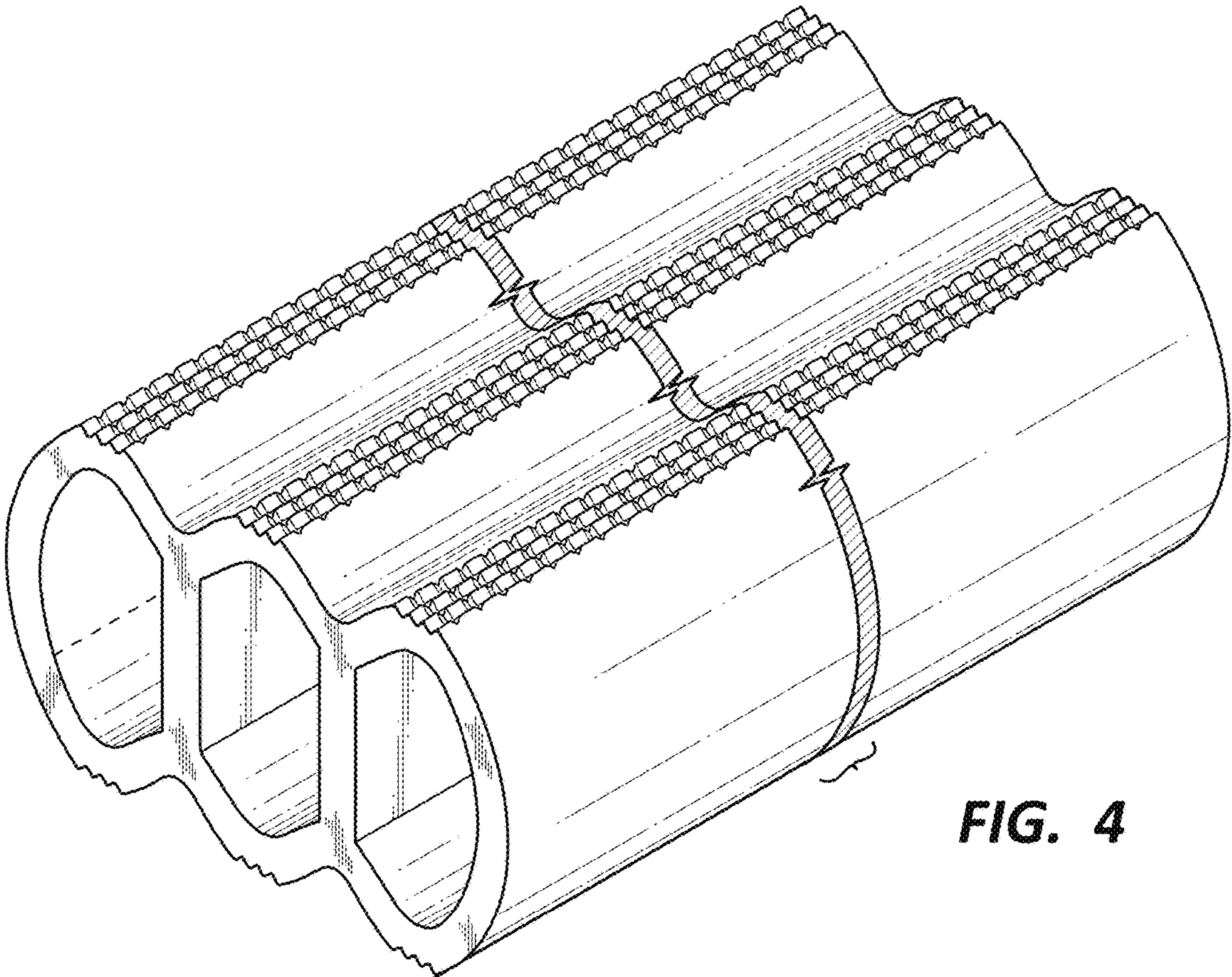

FIG. 4