



US00D806636S

(12) **United States Design Patent**
Lee et al.

(10) **Patent No.:** **US D806,636 S**
(45) **Date of Patent:** **** Jan. 2, 2018**

(54) **LANDING GEAR FOR AN AERIAL VEHICLE**

(71) Applicant: **GoPro, Inc.**, San Mateo, CA (US)

(72) Inventors: **Seungheon Lee**, Cupertino, CA (US);
John George Muhlenkamp, IV,
Brisbane, CA (US)

(73) Assignee: **GoPro, Inc.**, San Mateo, CA (US)

(**) Term: **15 Years**

(21) Appl. No.: **29/549,177**

(22) Filed: **Dec. 18, 2015**

(51) **LOC (11) Cl.** **12-07**

(52) **U.S. Cl.**
USPC **D12/345**

(58) **Field of Classification Search**
USPC D12/16.1, 305, 319, 326, 327, 328, 329,
D12/339, 344, 345, 214; D21/436, 441,
(Continued)

(56) **References Cited**

U.S. PATENT DOCUMENTS

D180,958 S * 9/1957 Papadakos D12/324
D635,199 S * 3/2011 Yuen D21/442
(Continued)

OTHER PUBLICATIONS

GoPro Replacement Landing Gear by GoPro. dated 2017. found
online [Sep. 25, 2017] <https://shop.gopro.com/accessories-2/karma-replacement-landing-gear/RQSGR-001.html>.*

(Continued)

Primary Examiner — Robert M. Spear

Assistant Examiner — Marissa J Cash

(74) *Attorney, Agent, or Firm* — Fenwick & West LLP

(57) **CLAIM**

The ornamental design for landing gear for an aerial vehicle,
as shown and described.

DESCRIPTION

FIG. 1 is a rear, top, and left side perspective view of a
folded landing gear for an aerial vehicle;
FIG. 2 is a front, bottom, and right side perspective view of
the folded landing gear for an aerial vehicle;
FIG. 3 is a rear elevation view of the folded landing gear for
an aerial vehicle.
FIG. 4 is a front elevation view of the folded landing gear
for an aerial vehicle.
FIG. 5 is a left side elevational view of the folded landing
gear for an aerial vehicle;
FIG. 6 is a right side elevational view of the folded landing
gear for an aerial vehicle;
FIG. 7 is a top plan view of the folded landing gear for an
aerial vehicle;
FIG. 8 is a bottom plan view of the folded landing gear for
an aerial vehicle.
FIG. 9 is a rear, top and left side perspective view of the open
landing gear for an aerial vehicle;
FIG. 10 is a front, bottom, and right side perspective view
of the open landing gear for an aerial vehicle;
FIG. 11 is a rear elevation view of the open landing gear for
an aerial vehicle;
FIG. 12 is a front elevation view of the open landing gear for
an aerial vehicle;
FIG. 13 is a left side elevational view of the open landing
gear for an aerial vehicle;
FIG. 14 is a right side elevational view of the open landing
gear for an aerial vehicle;
FIG. 15 is a top plan view of the open landing gear for an
aerial vehicle; and,
FIG. 16 is a bottom plan view of the open landing gear for
an aerial vehicle.

The broken lines in the drawings showing portions of the
landing gear are included for the purpose of illustrating
environmental structure and form no part of the claimed
design.

1 Claim, 16 Drawing Sheets

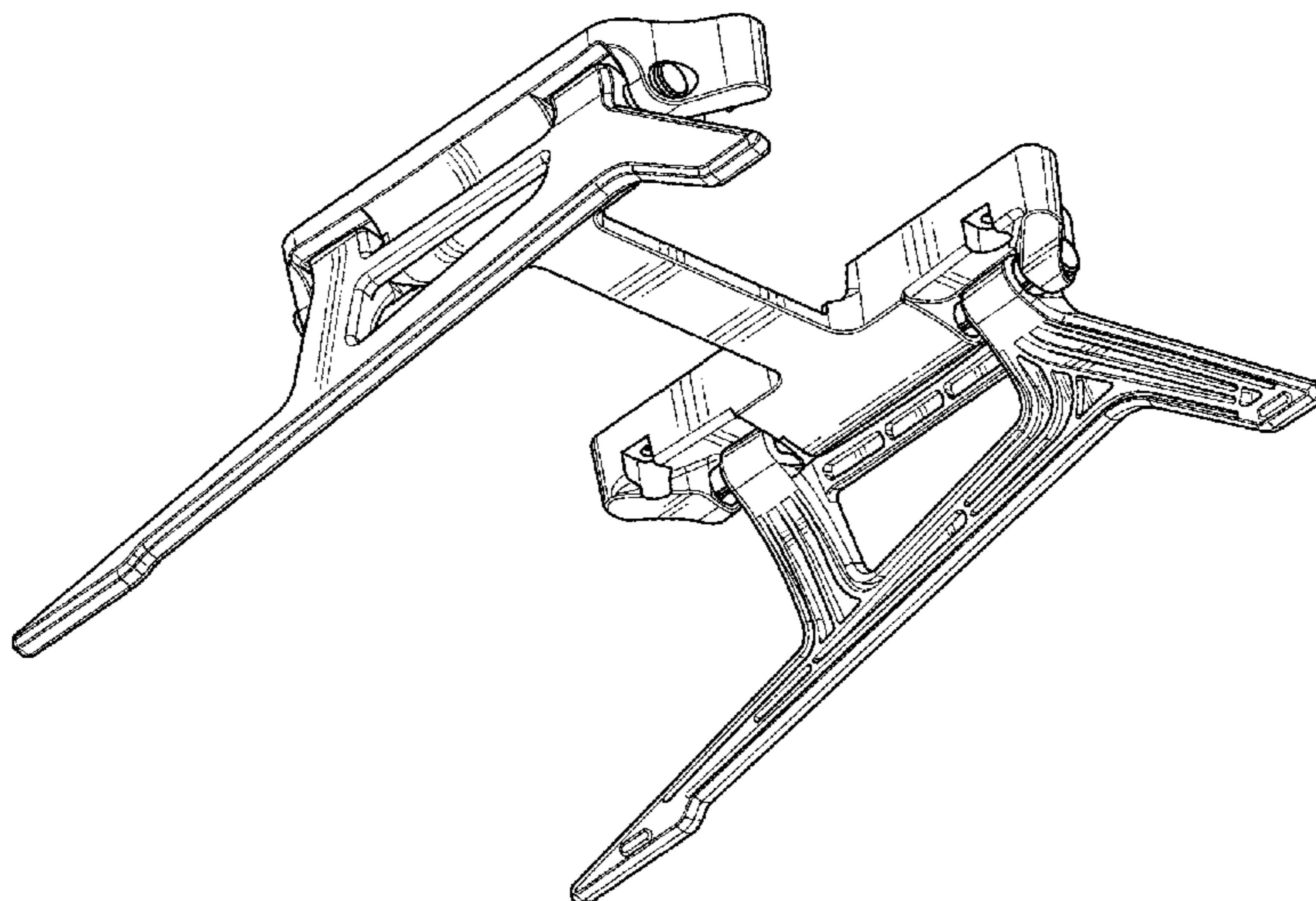

(58) **Field of Classification Search**

USPC D21/442, 450, 453, 454, 301, 570;
D23/370, 371, 411
CPC . B64C 1/069; B64C 1/06; B64C 27/32; B64F
1/00

See application file for complete search history.

(56) **References Cited**

U.S. PATENT DOCUMENTS

D691,514 S * 10/2013 Wang D12/16.1
D708,273 S * 7/2014 Kouyoumjian D12/328
D745,435 S * 12/2015 Park D12/16.1
D763,134 S * 8/2016 Wang D12/16.1
D767,043 S * 9/2016 Morrison D12/16.1
D793,486 S * 8/2017 Lee D21/453
D796,586 S * 9/2017 Chen D12/16.1
2015/0060606 A1* 3/2015 Wang B64C 39/024
244/175
2015/0321755 A1* 11/2015 Martin B64C 27/50
244/17.23
2016/0152345 A1* 6/2016 Molnar B64C 39/024
244/39

OTHER PUBLICATIONS

Examination Report for European Union Patent Application No.
002970715-0001/002970715-0002, dated Feb. 9, 2016, 5 Pages.

* cited by examiner

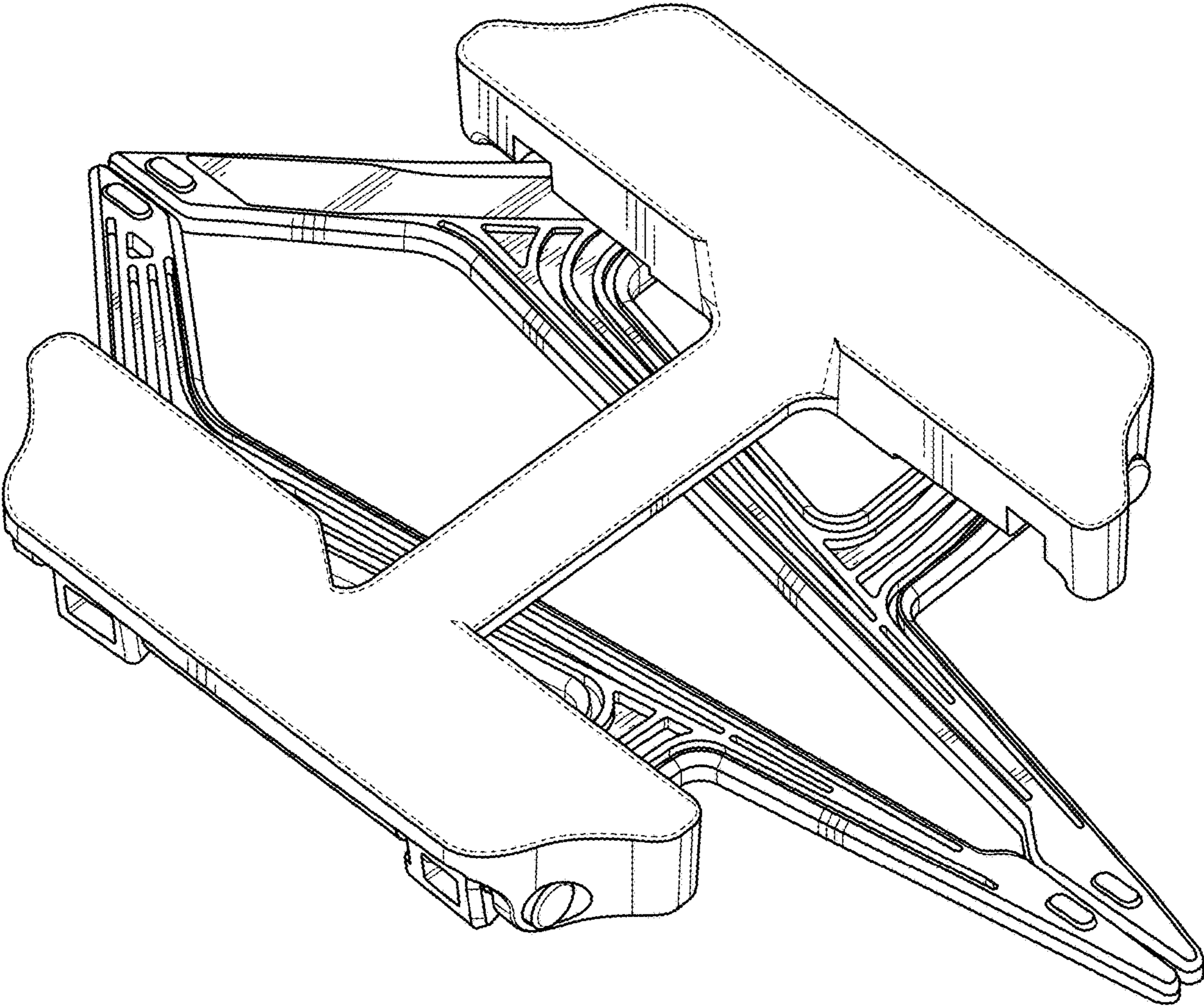

FIG. 1

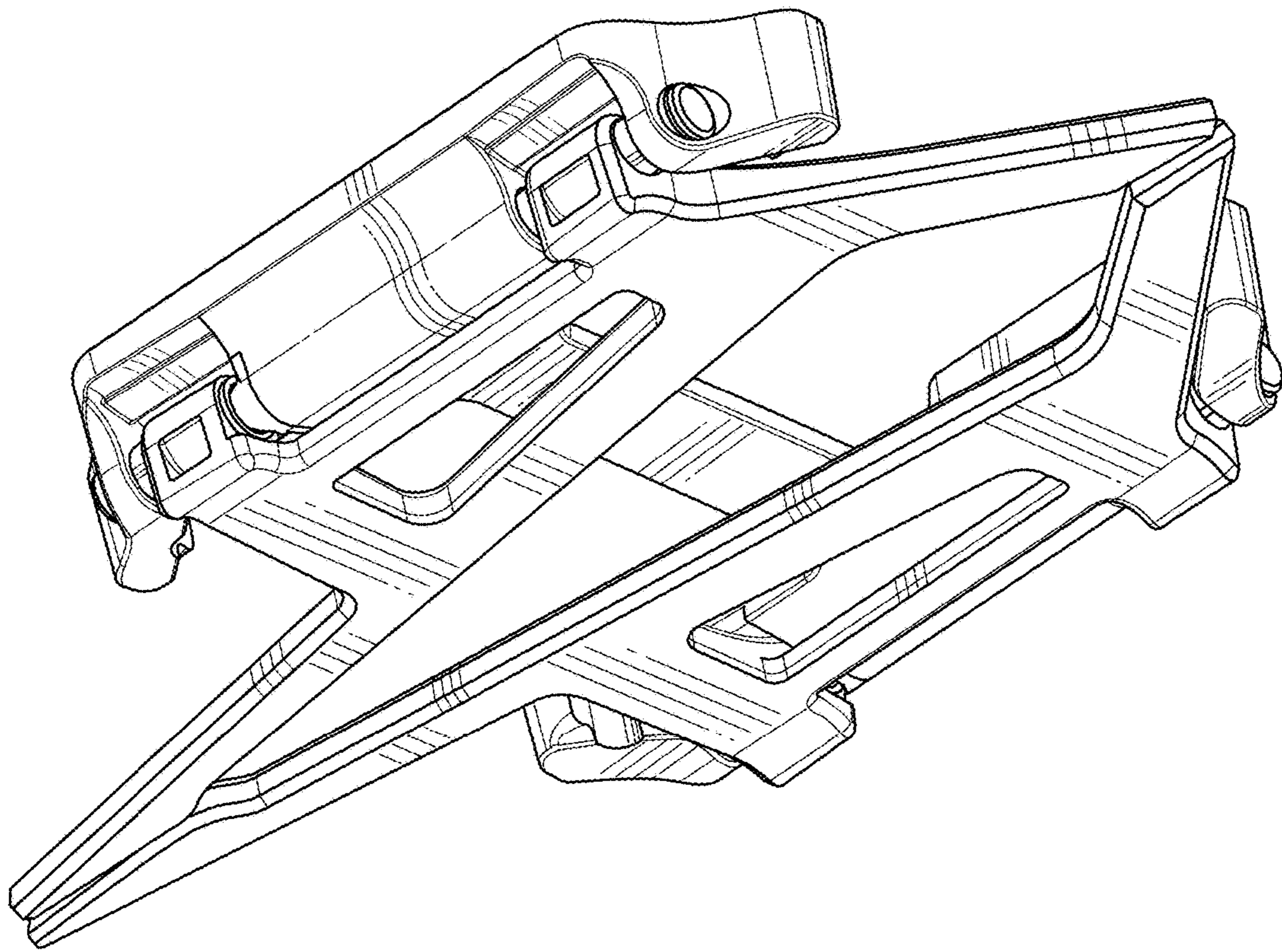

FIG. 2

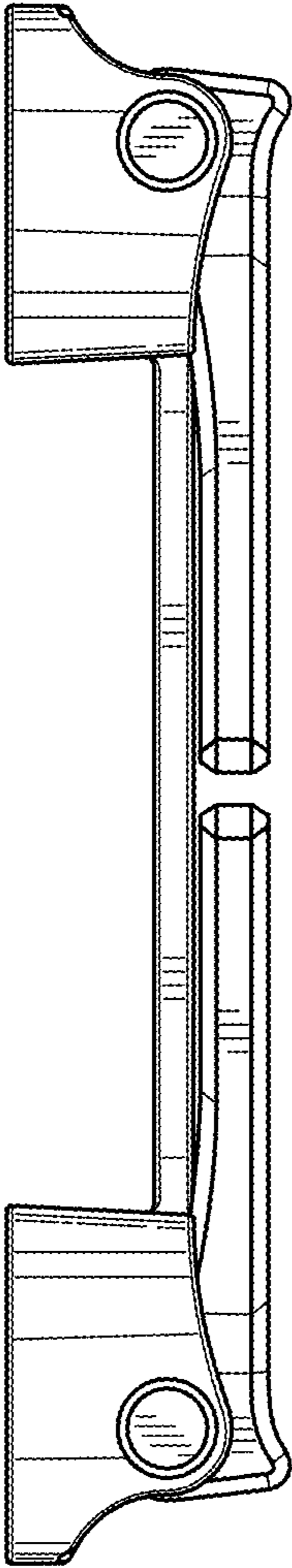

FIG. 3

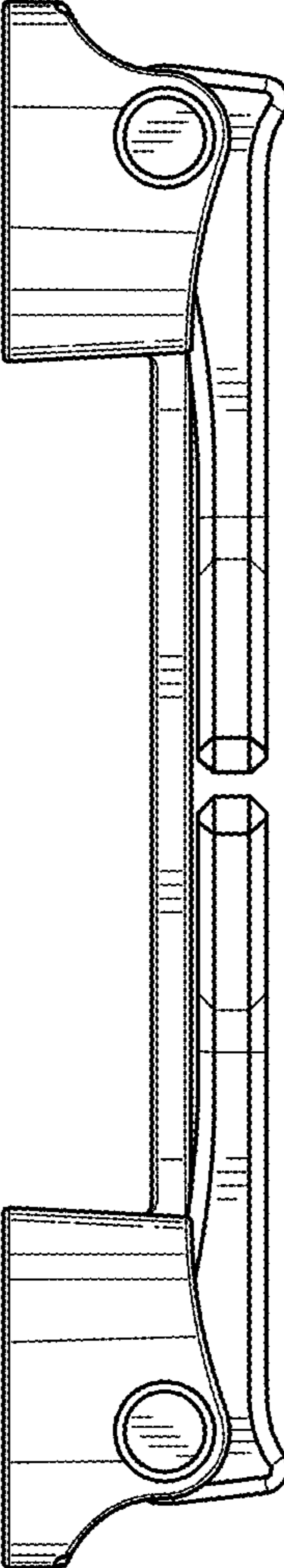

FIG. 4

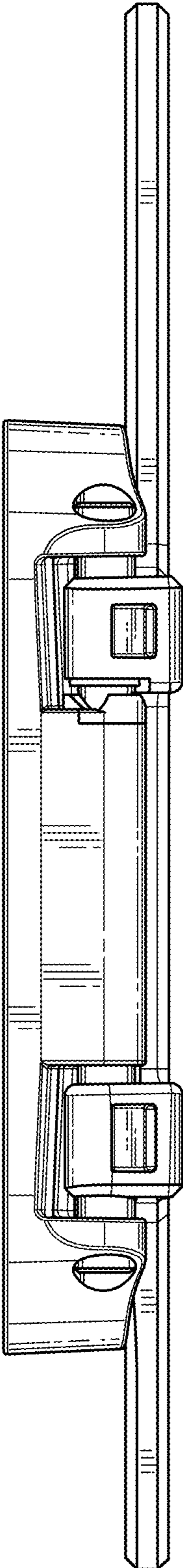

FIG. 5

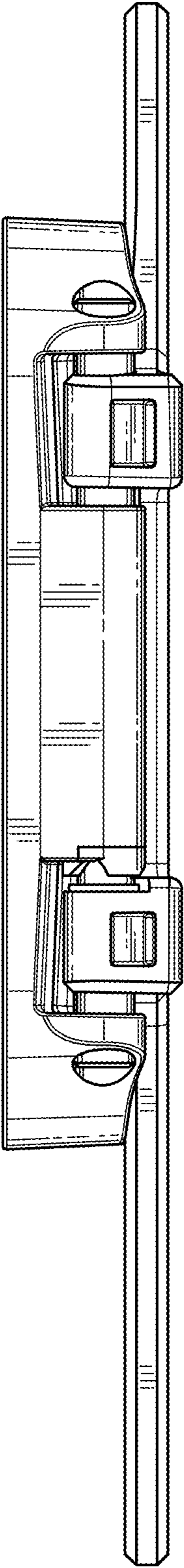

FIG. 6

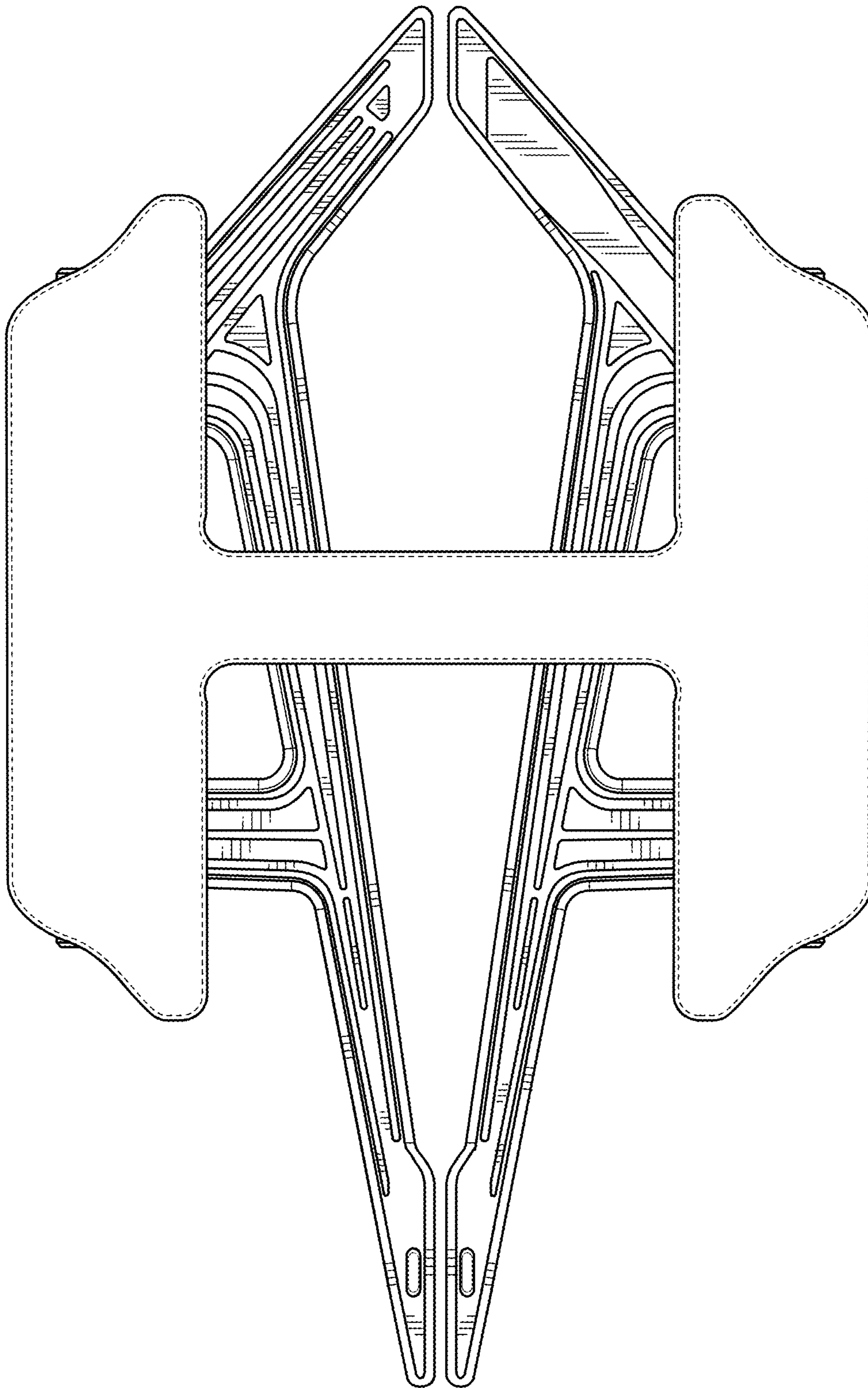

FIG. 7

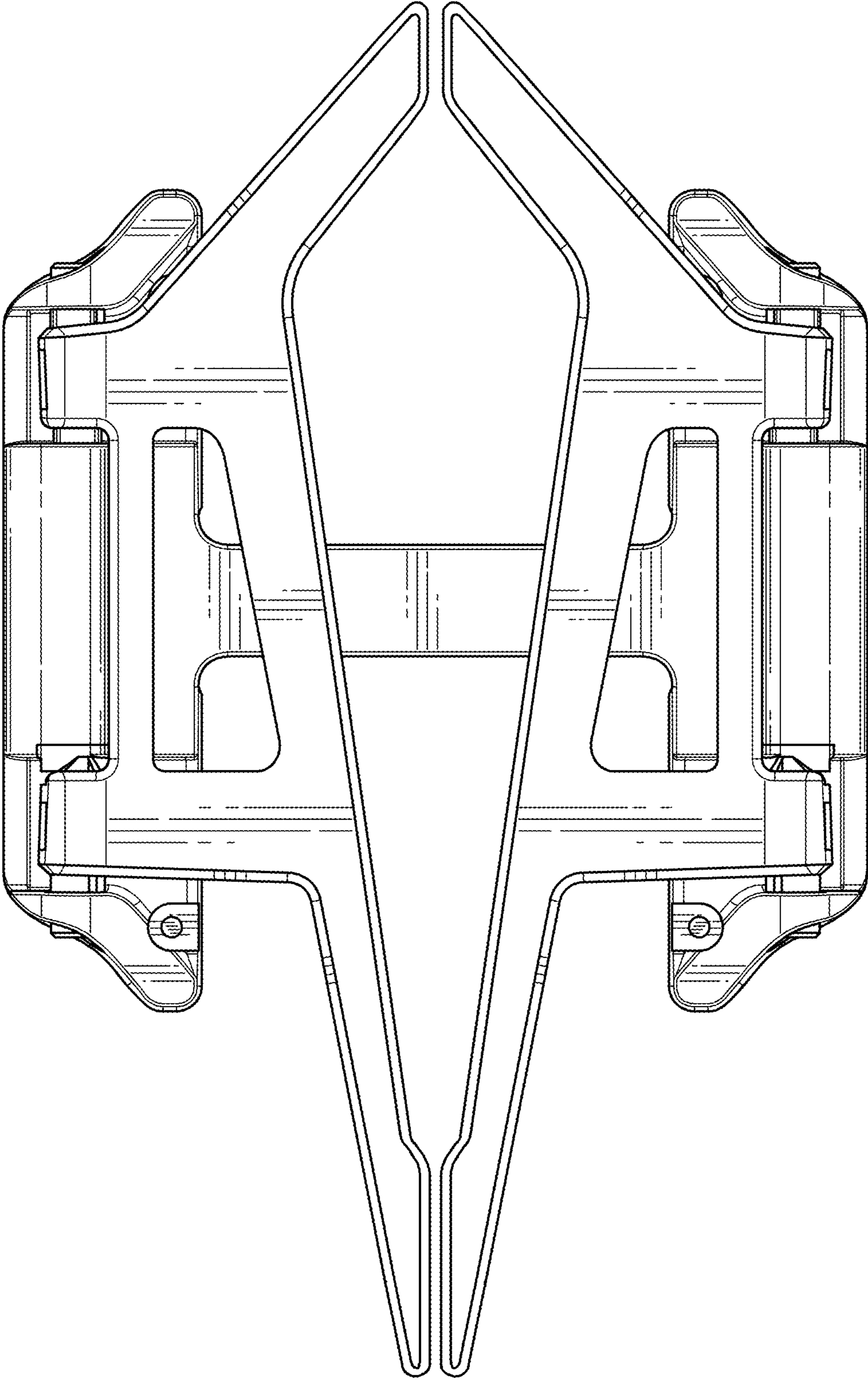

FIG. 8

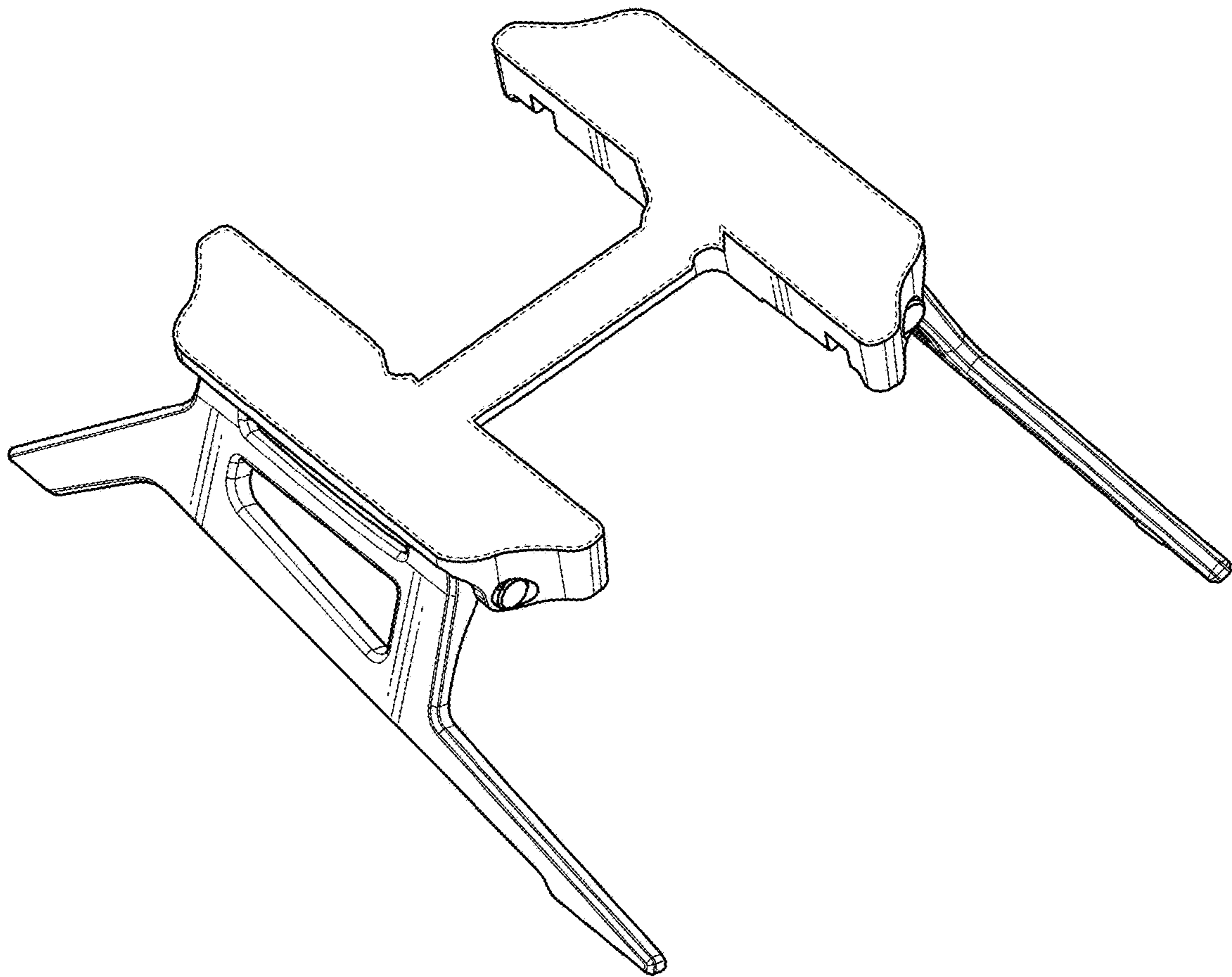

FIG. 9

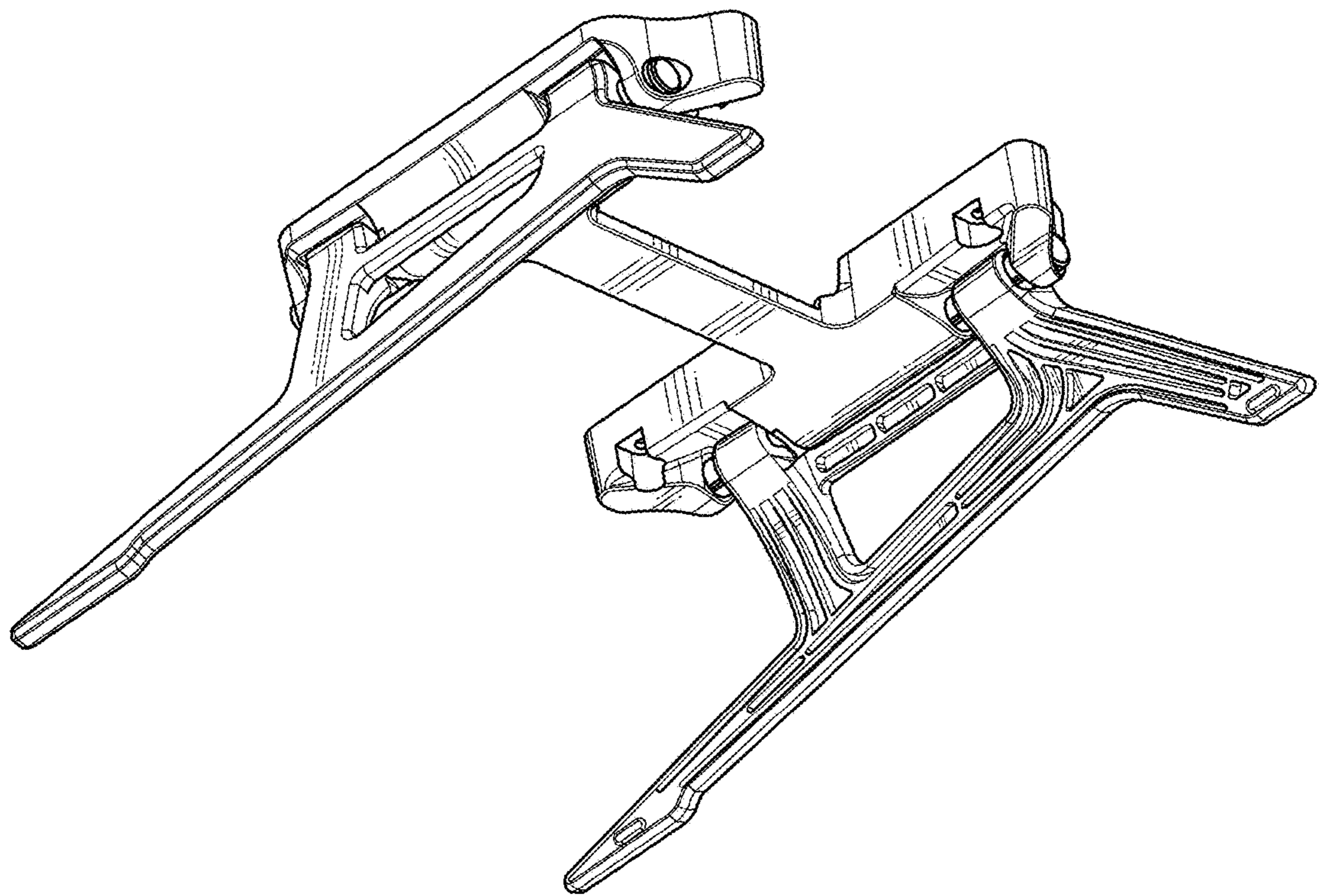

FIG. 10

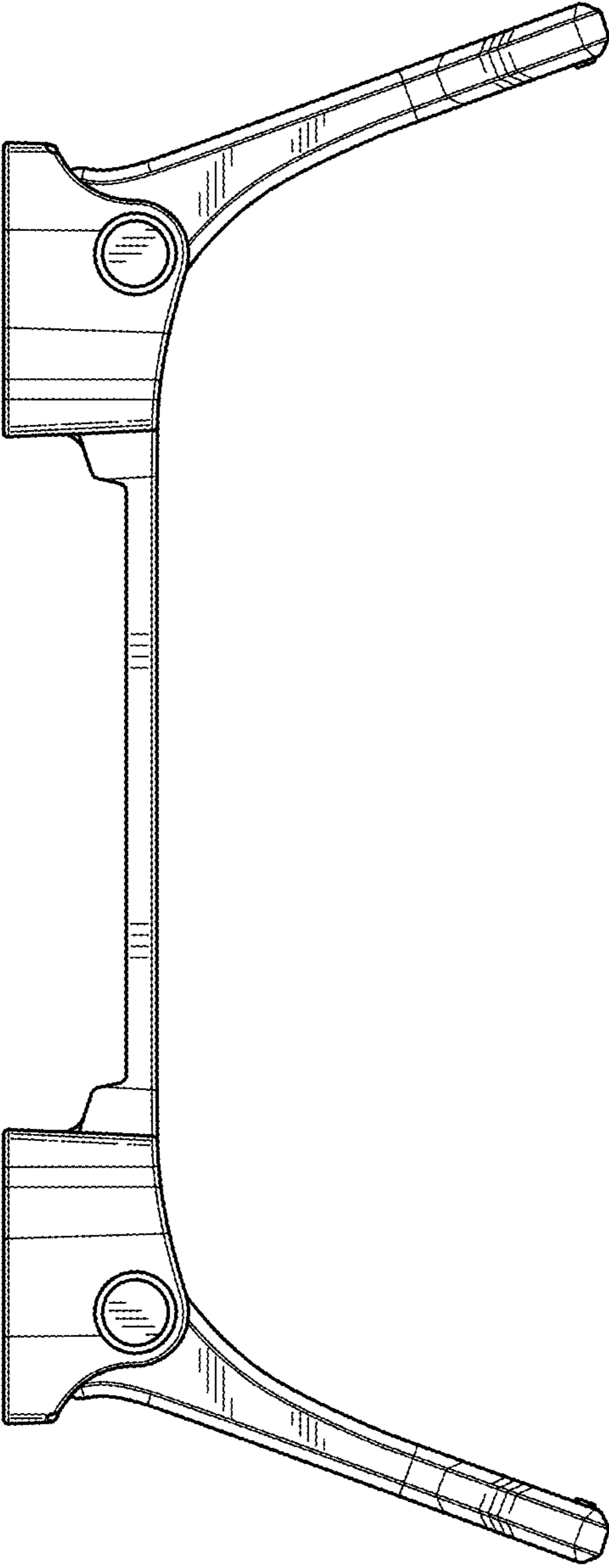

FIG. 11

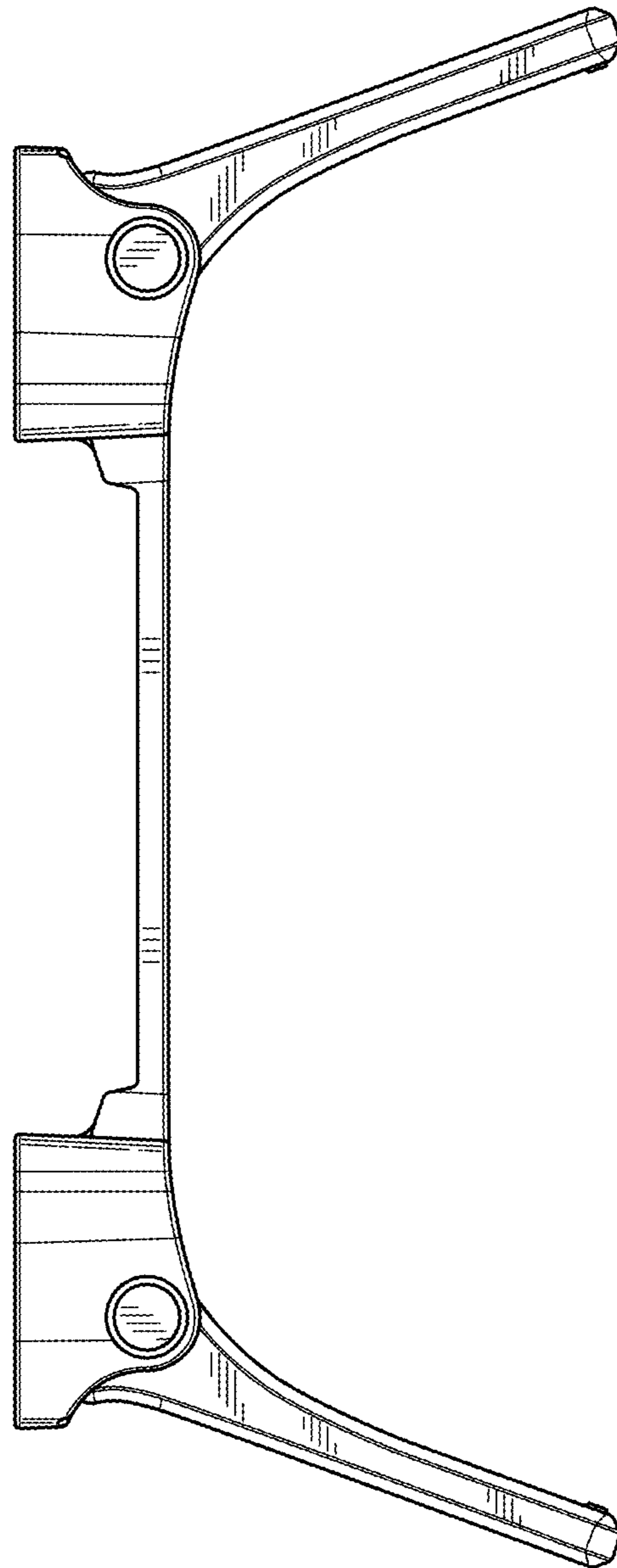

FIG. 12

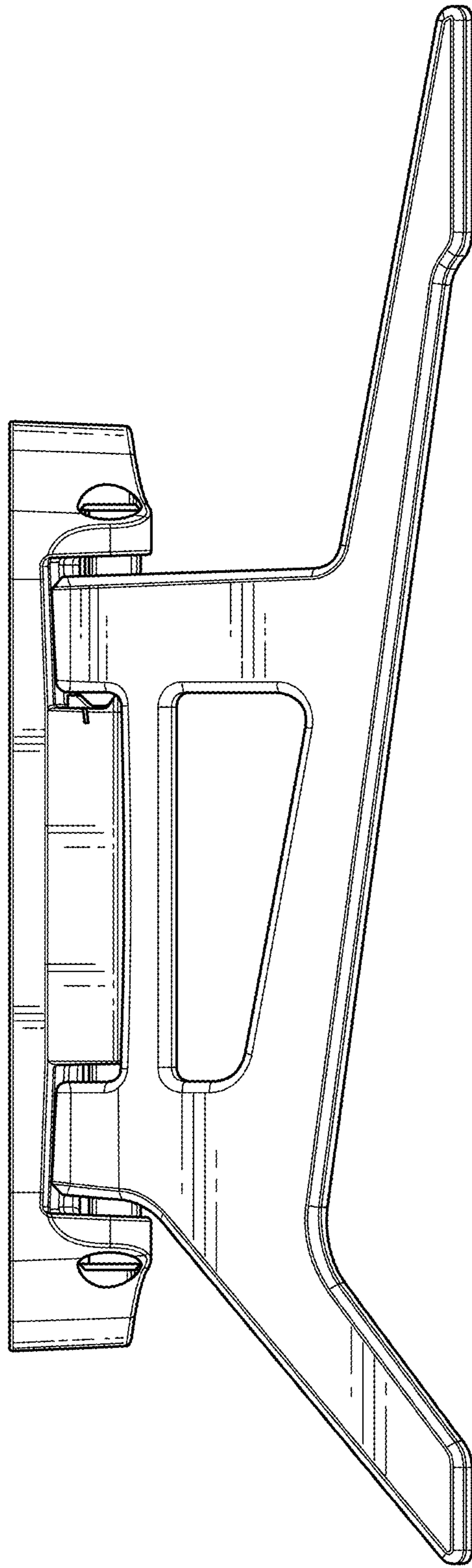

FIG. 13

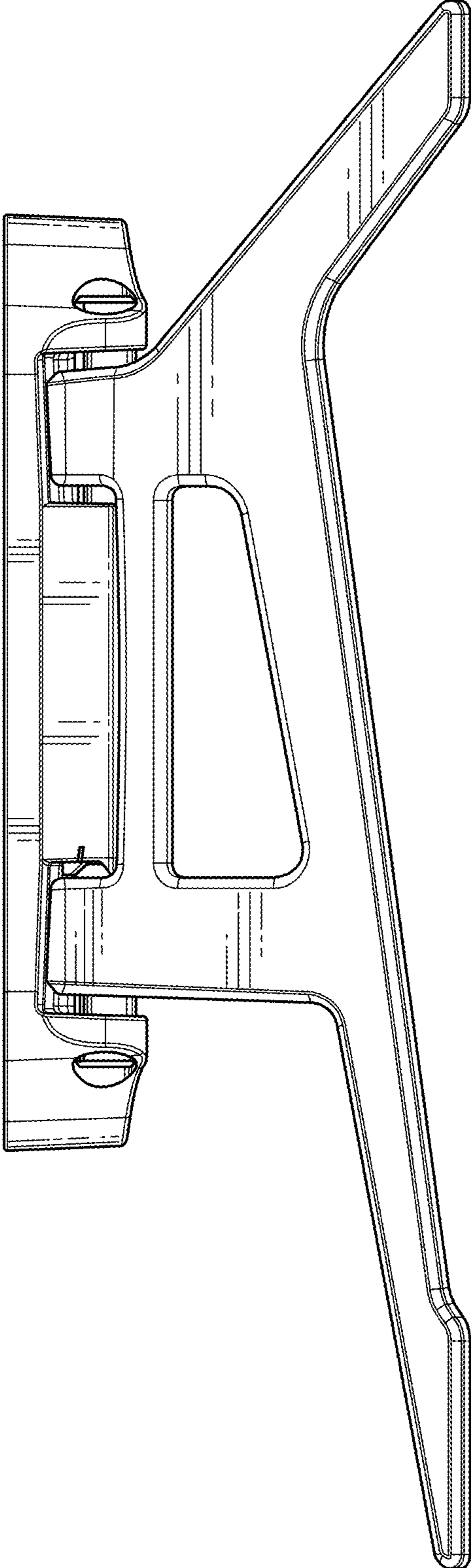

FIG. 14

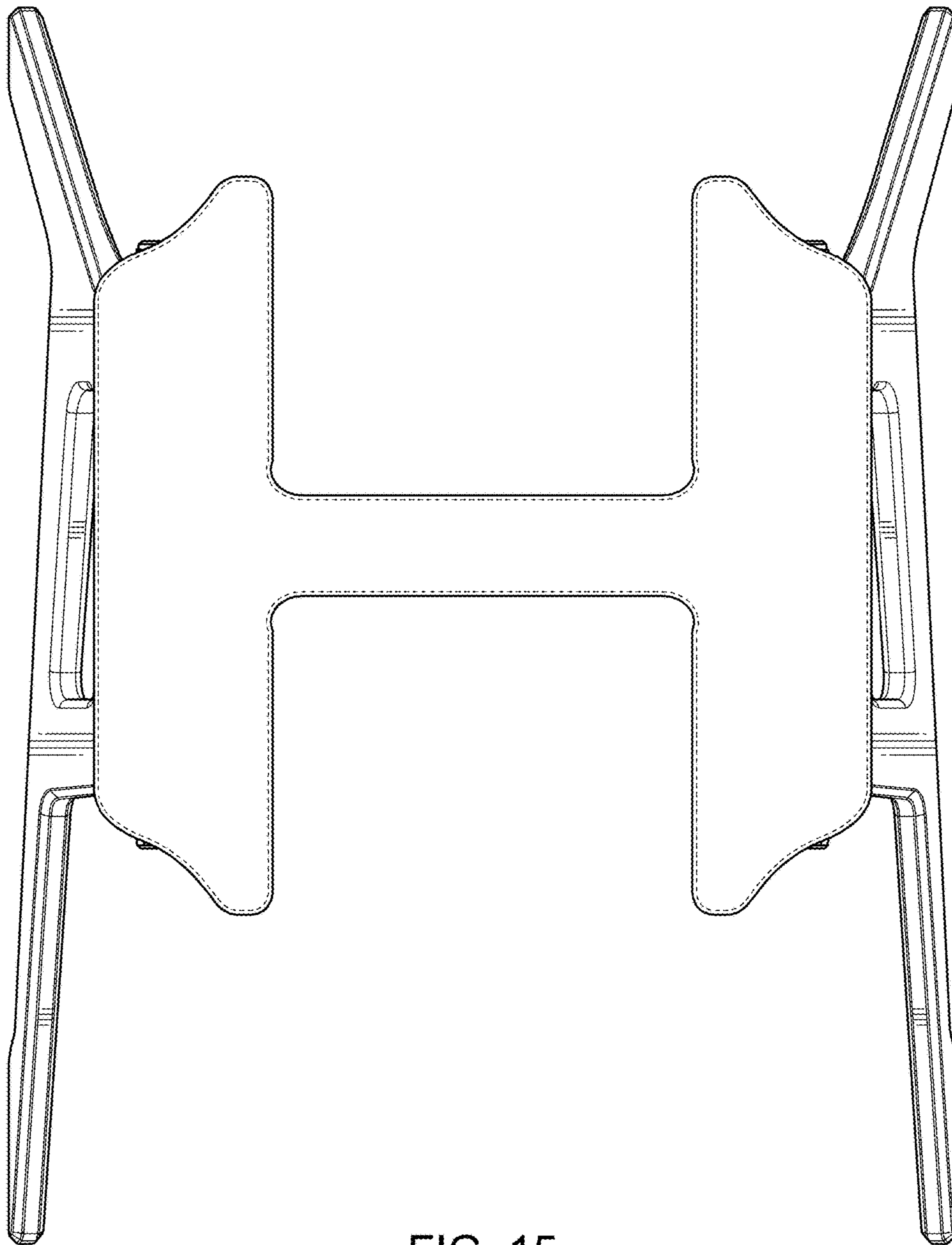

FIG. 15

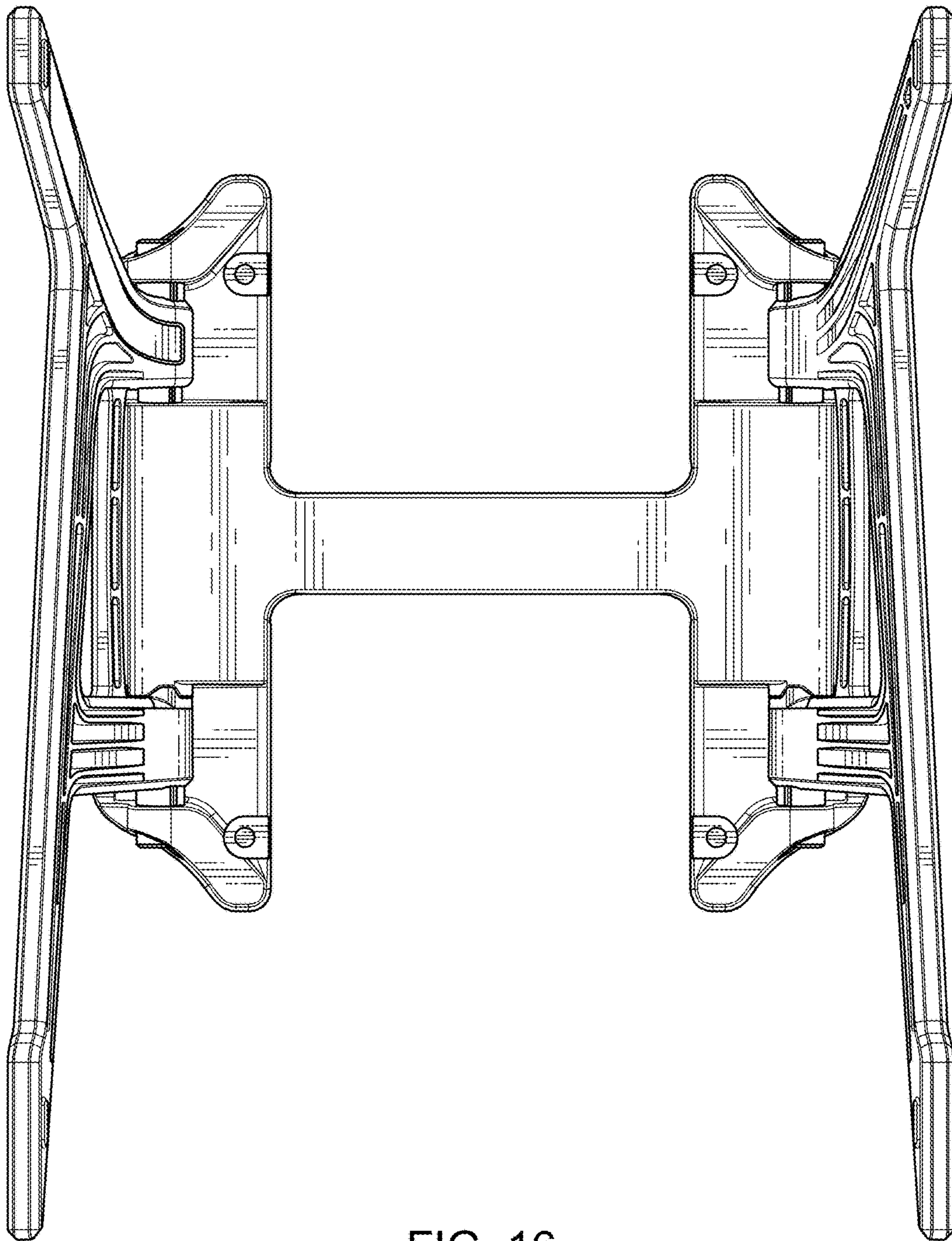

FIG. 16