



US00D806630S

(12) **United States Design Patent**
McMath

(10) **Patent No.:** **US D806,630 S**
(45) **Date of Patent:** **** Jan. 2, 2018**

- (54) **WHEEL**
- (71) Applicant: **Robert Roy McMath**, Riverside, CA (US)
- (72) Inventor: **Robert Roy McMath**, Riverside, CA (US)
- (**) Term: **15 Years**
- (21) Appl. No.: **29/553,701**
- (22) Filed: **Feb. 3, 2016**
- (51) **LOC (11) Cl.** **12-16**
- (52) **U.S. Cl.**
USPC **D12/211**
- (58) **Field of Classification Search**
USPC D12/204–213
CPC B60B 7/00; B60B 7/02; B60B 7/04; B60B 7/01; B60B 7/06; B60B 3/02; B60B 3/04; B60B 3/06; B60B 3/10; B60B 1/00; B60B 1/08; B60B 1/10; B60B 1/12
See application file for complete search history.

D536,655 S *	2/2007	Kim	D12/211
D545,749 S *	7/2007	Young	D12/211
D582,830 S *	12/2008	Musser	D12/211
D587,179 S *	2/2009	Pfeiffer	D12/209
D617,720 S *	6/2010	Zhao	D12/211
D671,062 S *	11/2012	Dilber	D12/211
D699,173 S *	2/2014	Zhao	D12/211
D704,117 S *	5/2014	Chung	D12/209
D704,121 S *	5/2014	Chung	D12/211
D706,196 S *	6/2014	Lee	D12/211
D722,937 S *	2/2015	Johnson	D12/209
D727,825 S *	4/2015	Chung	D12/211
D751,017 S *	3/2016	Chung	D12/209
D764,375 S *	8/2016	Chung	D12/211
D765,574 S *	9/2016	Hale, Jr.	D12/211
D768,045 S *	10/2016	Curic	D12/209
D782,385 S *	3/2017	Zhao	D12/211
D786,768 S *	5/2017	Youssef	D12/211

* cited by examiner

Primary Examiner — Sandra Snapp
(74) *Attorney, Agent, or Firm* — Curtis L. Harrington; Harrington & Harrington

(57) **CLAIM**

The ornamental design for a wheel, as shown and described.

DESCRIPTION

FIG. 1 is a front perspective view of the wheel; and, FIG. 2 is a front view thereof.
In the drawings, the broken lines depict environmental subject matter only and form no part of the claimed design.

1 Claim, 1 Drawing Sheet

- (56) **References Cited**
U.S. PATENT DOCUMENTS
D396,208 S * 7/1998 Baumgartner D12/211
D408,346 S * 4/1999 Goplen D12/211
D450,030 S * 11/2001 Pfeiffer D12/211
D500,003 S * 12/2004 Guevara D12/211
D505,375 S * 5/2005 Kushartanto D12/211

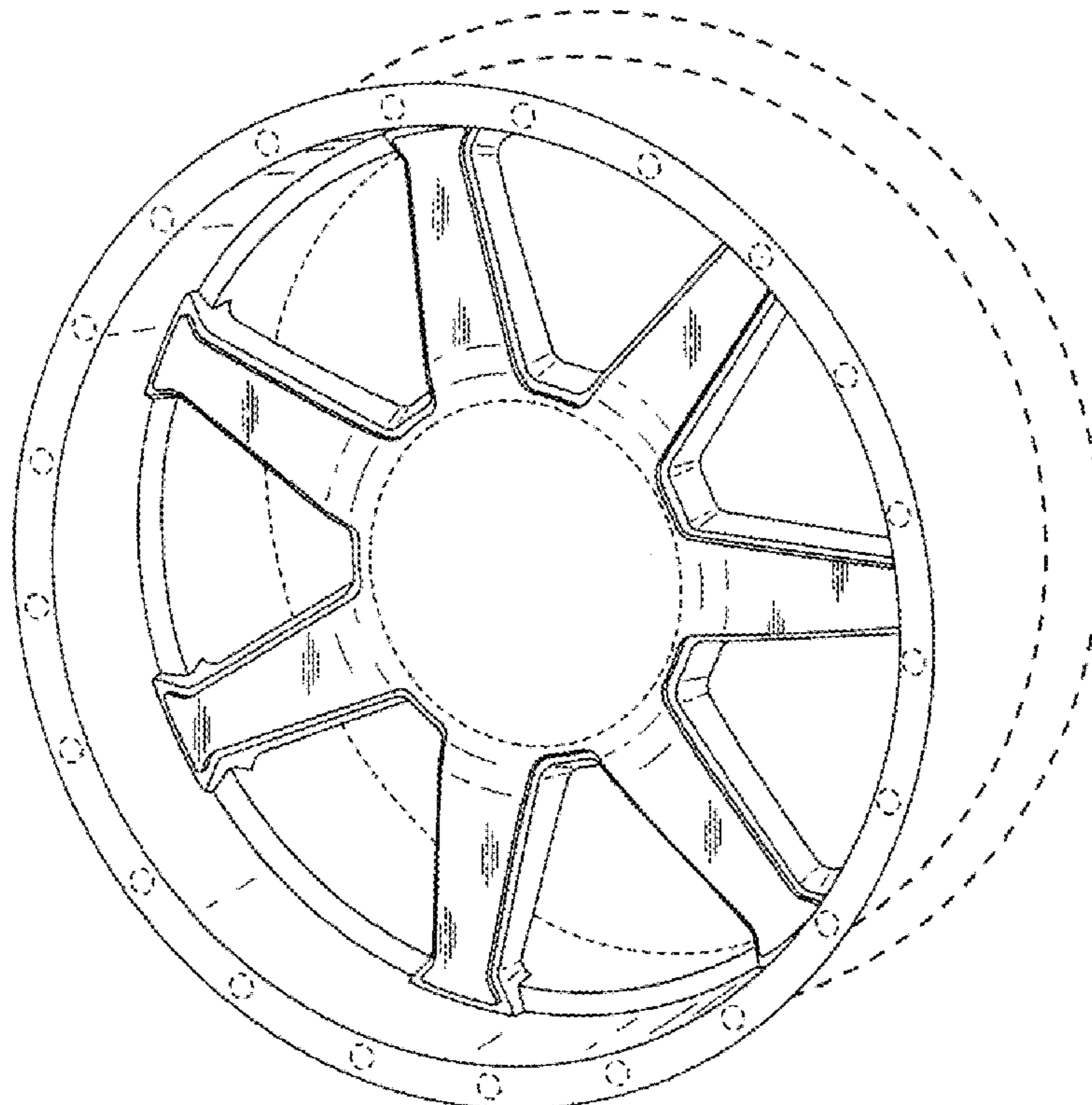

Fig. 1

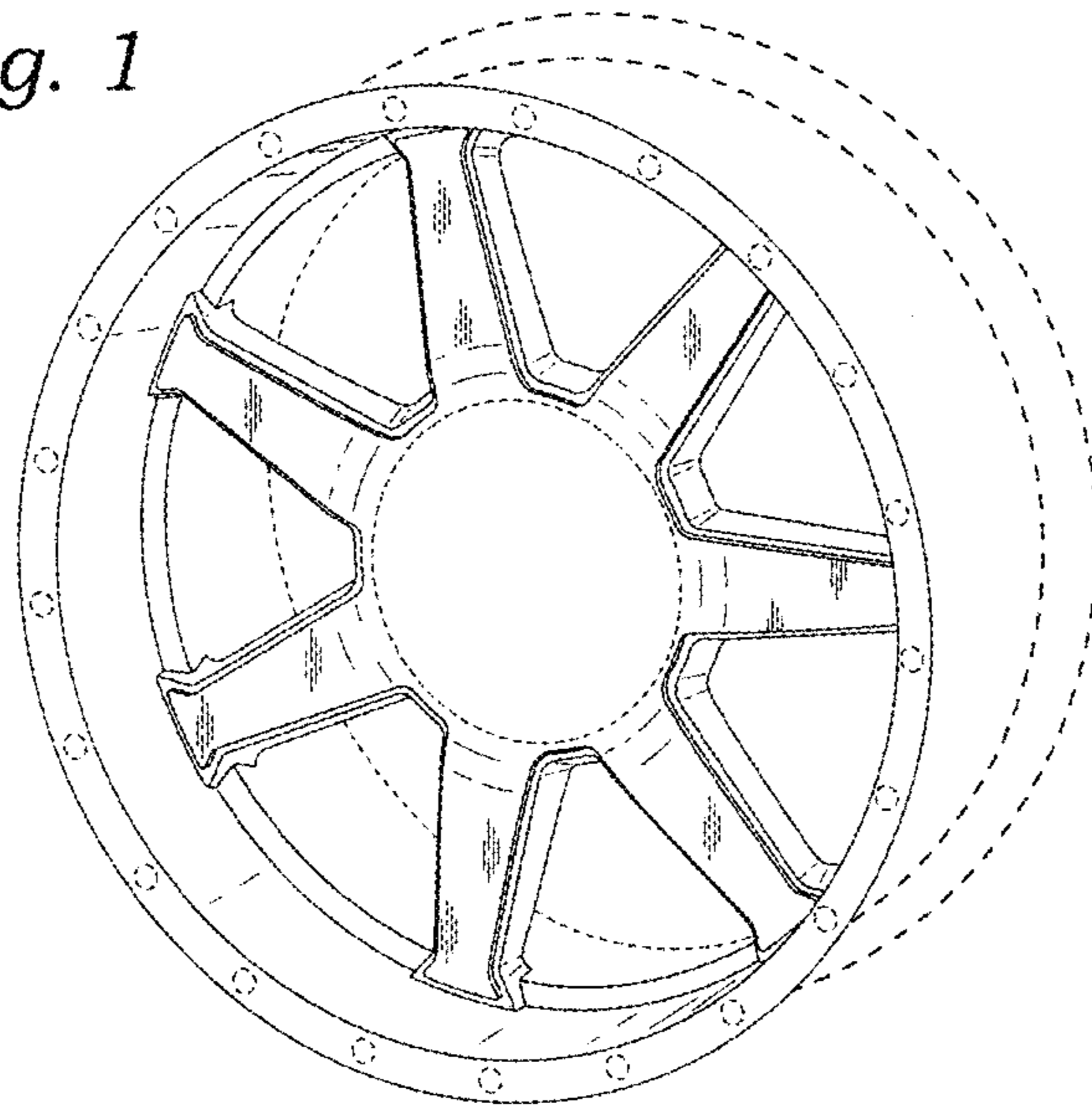

Fig. 2

