



US00D806264S

(12) **United States Design Patent** (10) **Patent No.:** **US D806,264 S**
Music et al. (45) **Date of Patent:** **** Dec. 26, 2017**

(54) **RETAIL FIXTURE**

(71) Applicant: **Sonos, Inc.**, Santa Barbara, CA (US)

(72) Inventors: **Fernando Music**, Santa Barbara, CA (US); **Anthony Sperduti**, Santa Barbara, CA (US)

(73) Assignee: **Sonos, Inc.**, Santa Barbara, CA (US)

(**) Term: **15 Years**

(21) Appl. No.: **29/551,801**

(22) Filed: **Jan. 15, 2016**

(51) **LOC (10) Cl.** **25-03**

(52) **U.S. Cl.**
USPC **D25/17**

(58) **Field of Classification Search**

USPC D21/494, 500, 501, 502, 506, 507, 508, D21/511, 836, 838; D25/1, 3, 4, 12, 15, D25/16, 17, 21, 22, 23, 24, 25, 26, 29, D25/30, 34, 56, 57, 58, 59, 61, 138, 139, D25/199

CPC E04B 1/99; E04B 2/30; E04F 8/02; G06F 3/048; G06F 3/16; G06N 5/02; H03G 3/00

See application file for complete search history.

(56) **References Cited**

U.S. PATENT DOCUMENTS

D55,485 S *	6/1920	Payne	D21/511
D262,098 S *	12/1981	Odle	D11/133
D432,593 S *	10/2000	Naughton	D21/511
D505,176 S *	5/2005	Wehner	D21/834
D569,450 S *	5/2008	Halliday	D21/511
D569,451 S *	5/2008	Halliday	D21/511
D623,242 S *	9/2010	Greer	D21/511
D634,445 S *	3/2011	Mason	D21/837
D635,279 S *	3/2011	Mathon	D25/138
D664,217 S *	7/2012	Jolly, III	D21/511
D682,951 S *	5/2013	Sandhei	D21/506

(Continued)

OTHER PUBLICATIONS

“Baristart Coffee”, Knows Only Blazing, Jun. 10, 2015, <http://k-o-blazing.jugem.jp/?eid=37> on Aug. 25, 2017, 3 pages.

(Continued)

Primary Examiner — Manpreet S Matharu

Assistant Examiner — Suzanne E Tisdell

(74) *Attorney, Agent, or Firm* — KPPB LLP

(57) **CLAIM**

The ornamental design for a retail fixture, as shown and described.

DESCRIPTION

FIG. 1 is a first isometric view of a retail fixture in accordance with an embodiment of the invention.

FIG. 2 is a second isometric view of the retail fixture in accordance with the embodiment of FIG. 1.

FIG. 3 is a front elevational view of the retail fixture in accordance with the embodiment of FIG. 1.

FIG. 4 is a rear elevational view of the retail fixture in accordance with the embodiment of FIG. 1.

FIG. 5 is a first side elevational view of the retail fixture in accordance with the embodiment of FIG. 1.

FIG. 6 is a second side elevational view of the retail fixture in accordance with the embodiment of FIG. 1.

FIG. 7 is a top elevational view of the retail fixture in accordance with the embodiment of FIG. 1; and,

FIG. 8 is a bottom elevational view of the retail fixture in accordance with the embodiment of FIG. 1.

Any shading on the figures is provided only to distinguish between the flat and contoured portions of the retail fixture, such shading patterns are not intended to be viewed as part of the claimed retail fixture. The evenly-spaced broken lines depict environment and do not form part of the claimed design. The dot-dash broken lines illustrate boundaries and do not form part of the claimed design.

1 Claim, 4 Drawing Sheets

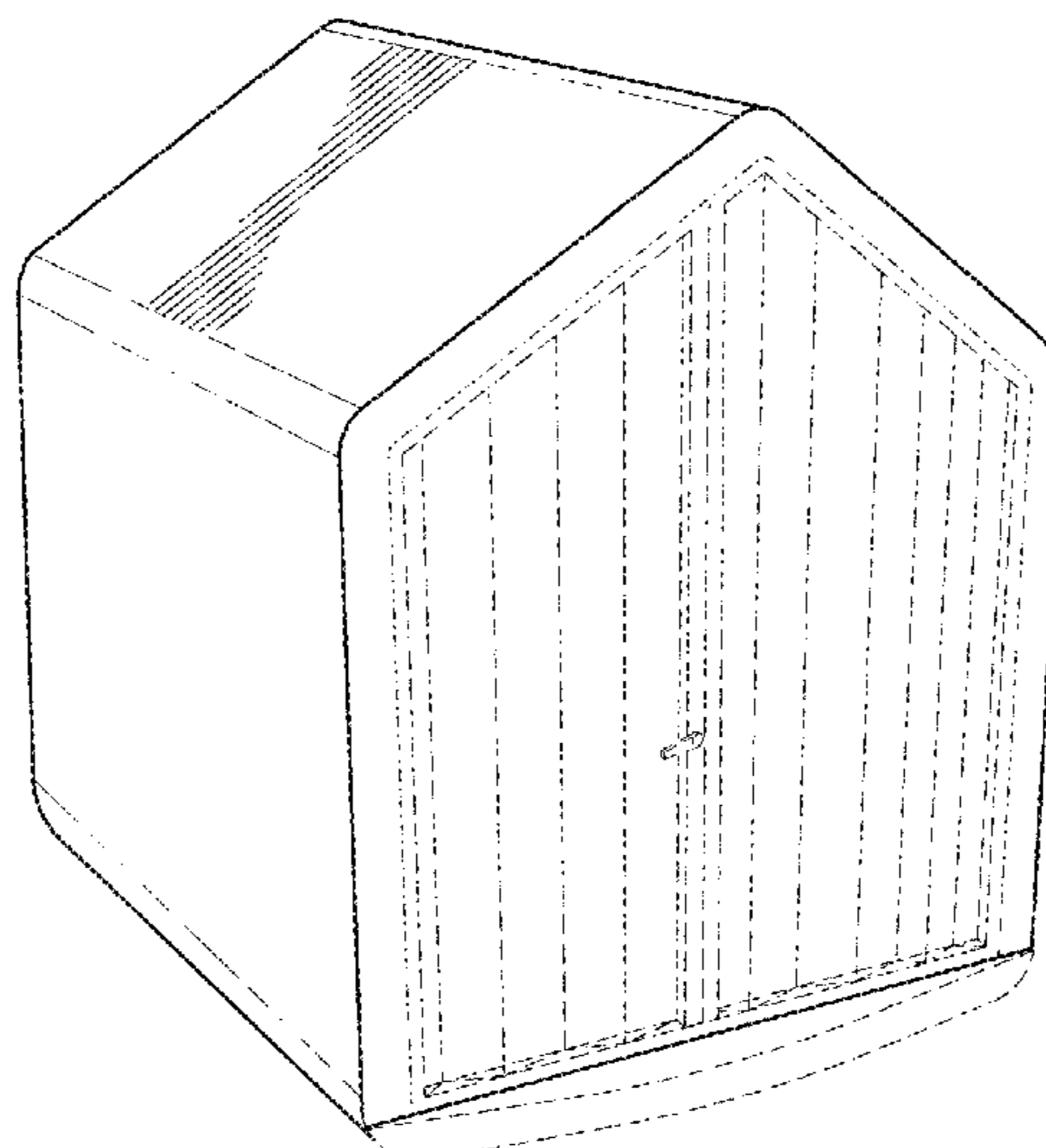

(56)

References Cited

U.S. PATENT DOCUMENTS

D699,793 S * 2/2014 Gomez D21/511
D735,276 S * 7/2015 Radu D21/511

OTHER PUBLICATIONS

“Baristart Coffee”, Porter’s Paints Blog, Jun. 10, 2015, retrieved from http://blog.nengo.jp/porters_paints/2015/06/baristart-coffee.html on Aug. 25, 2017, 3 pages.

“City of light”, Behance, Philips—D’art Design Gruppe, Aug. 31, 2011, retrieved from <https://www.behance.net/gallery/2046869/city-of-light-philips> on Aug. 24, 2017, 8 pages.

“Human Touch Group Pavilvion in Poznan”, Modelina, Feb. 1, 2015, retrieved from <http://www.modelina-architekci.com/project/htg-poznan2015/> on Aug. 24, 2017, 13 pages.

“Rehau Booth”, Rehau, Mar. 31, 2015, Batimat, Russia, retrieved from <https://i.pining.com/originals/c5/9d/f7/c59df7d1500f2684460908fff44b6abf.jpg> on Aug. 25, 2017, 1 page.

“Xilos Temporary Architecture”, Behance, Bosch Klimahouse Exhibition Design, Feb. 17, 2015, retrieved from <https://www.behance.net/gallery/23738217/Bosch-Klimahouse> on Aug. 24, 2017, 6 pages.

* cited by examiner

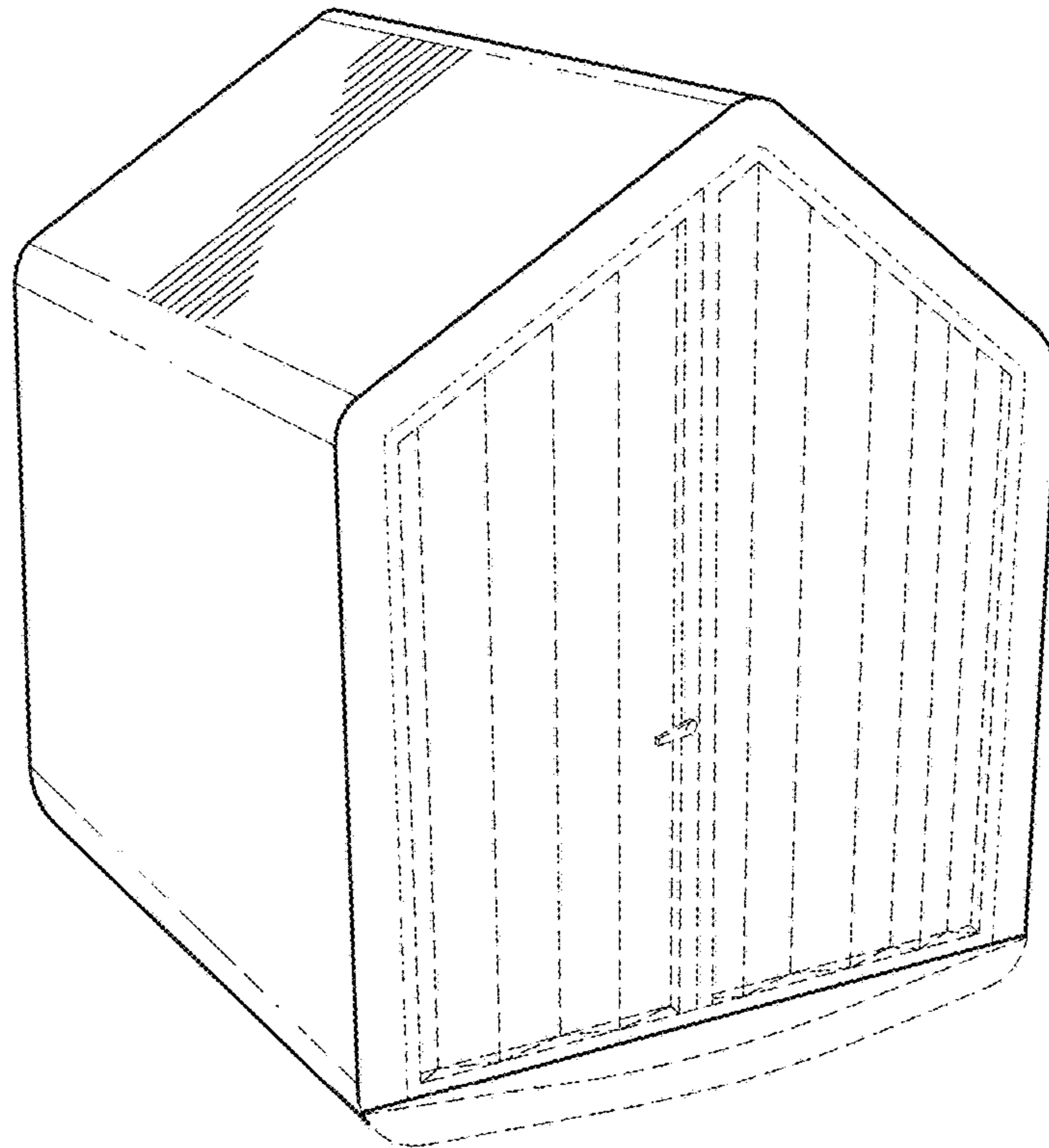

Fig. 1

Fig. 2

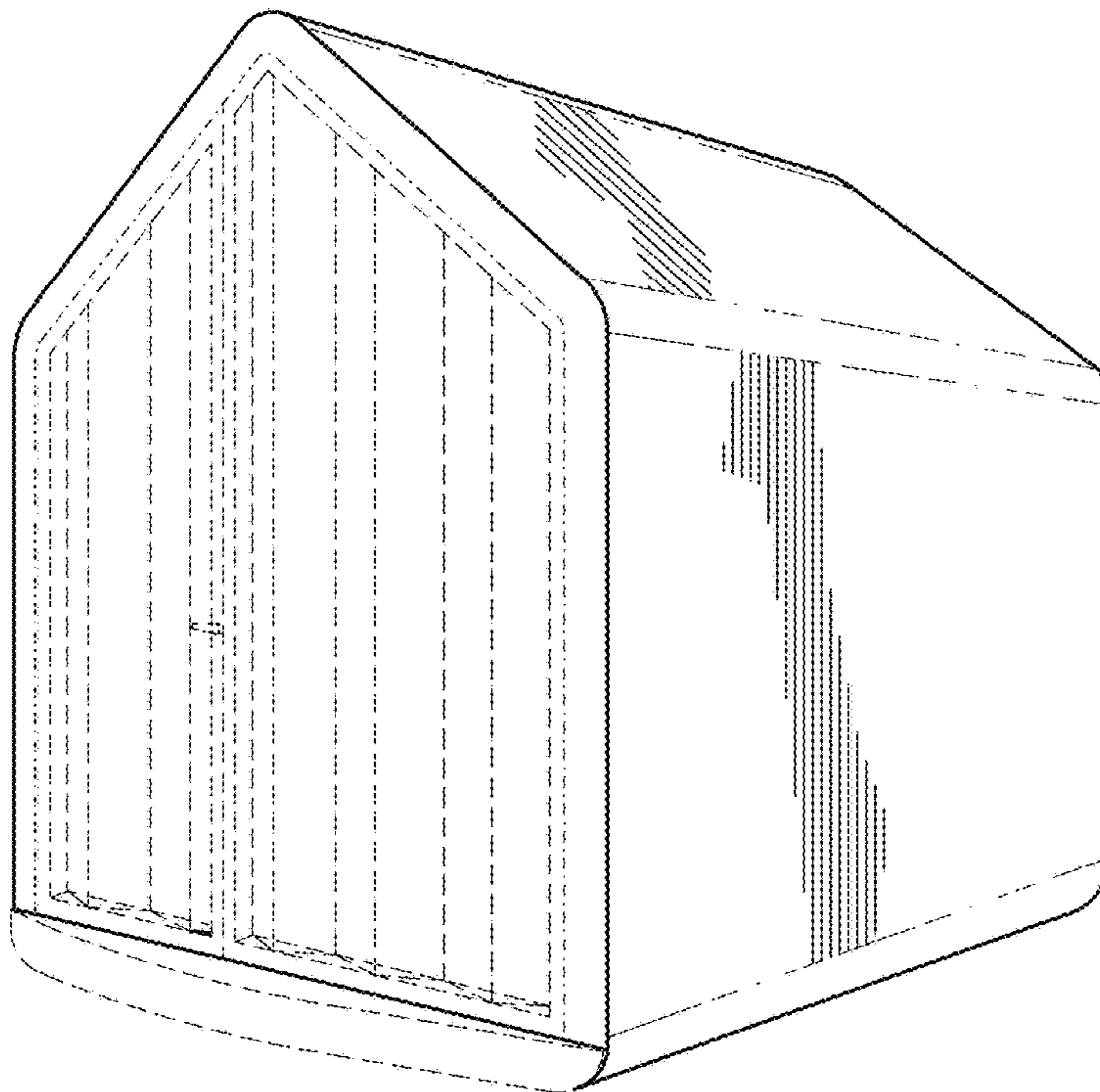

Fig. 3

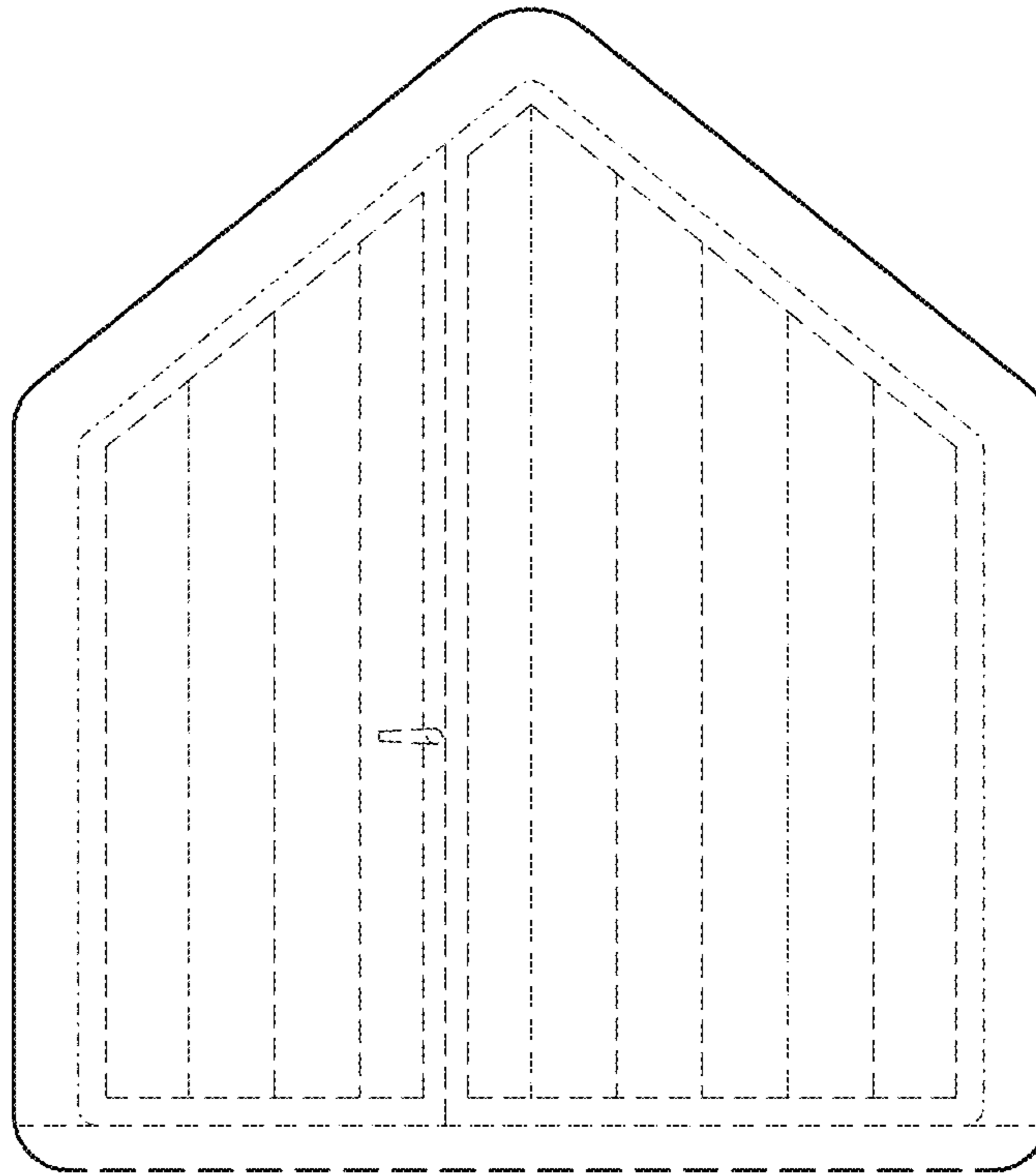

Fig. 4

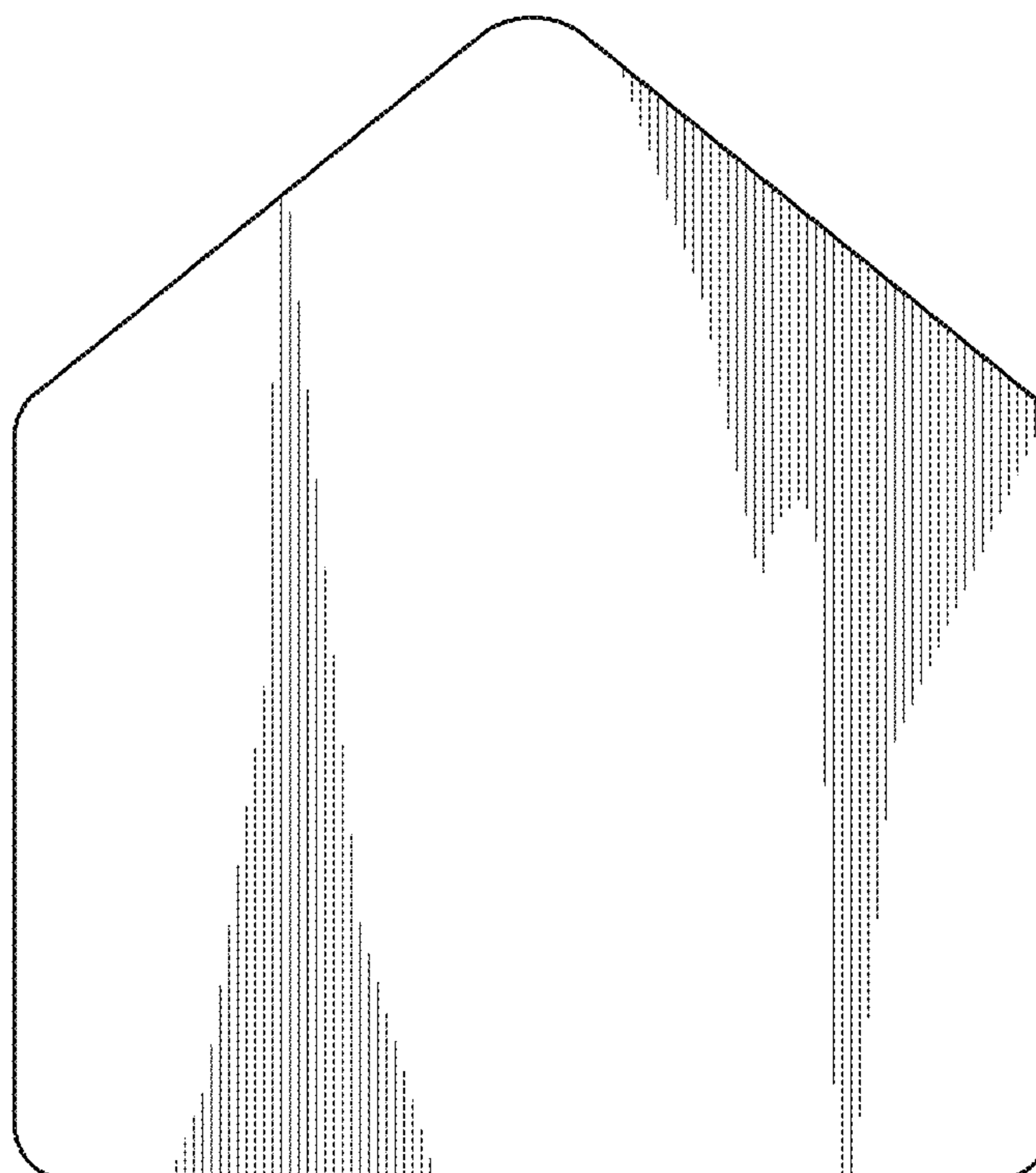

Fig. 5

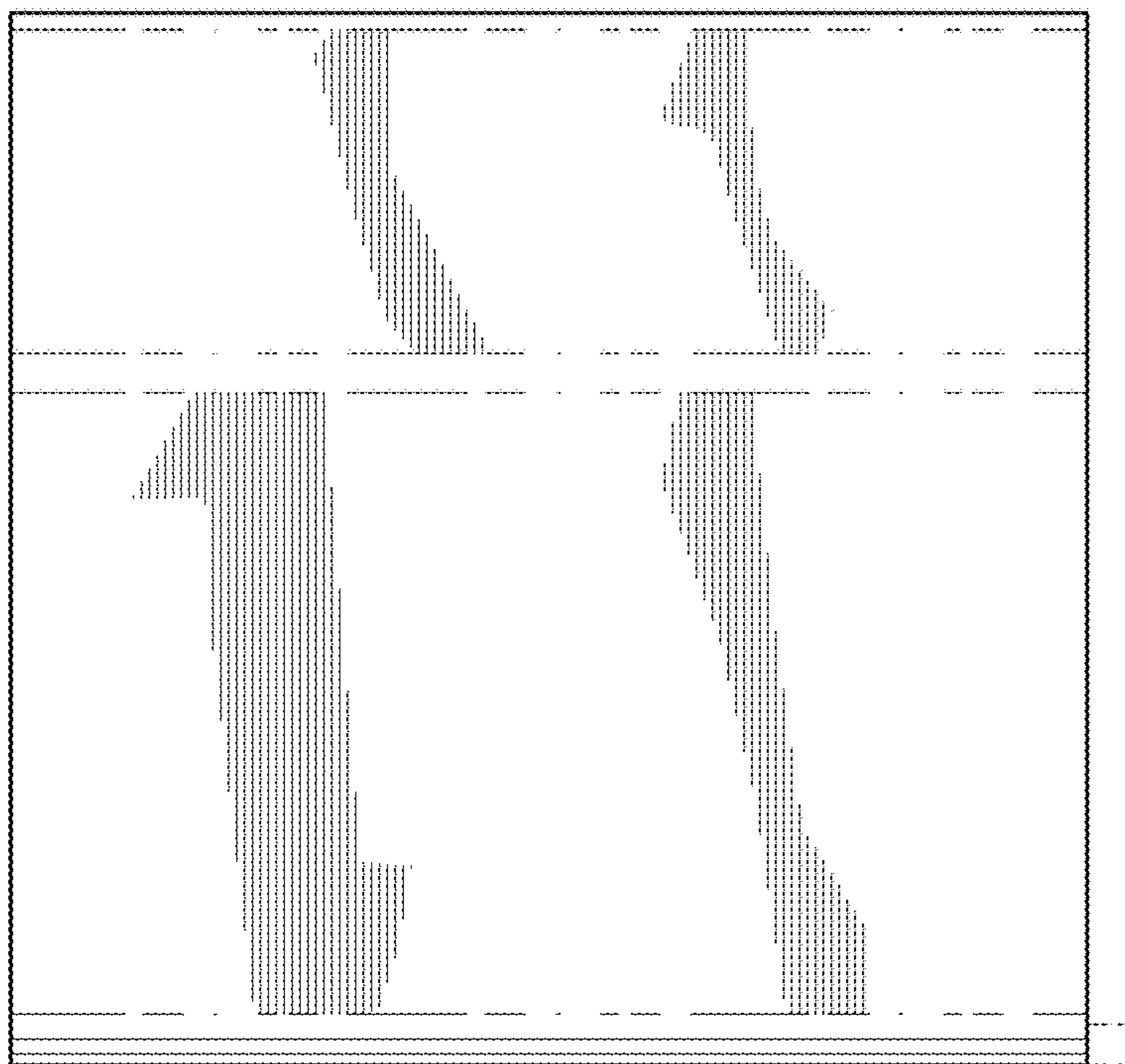

Fig. 6

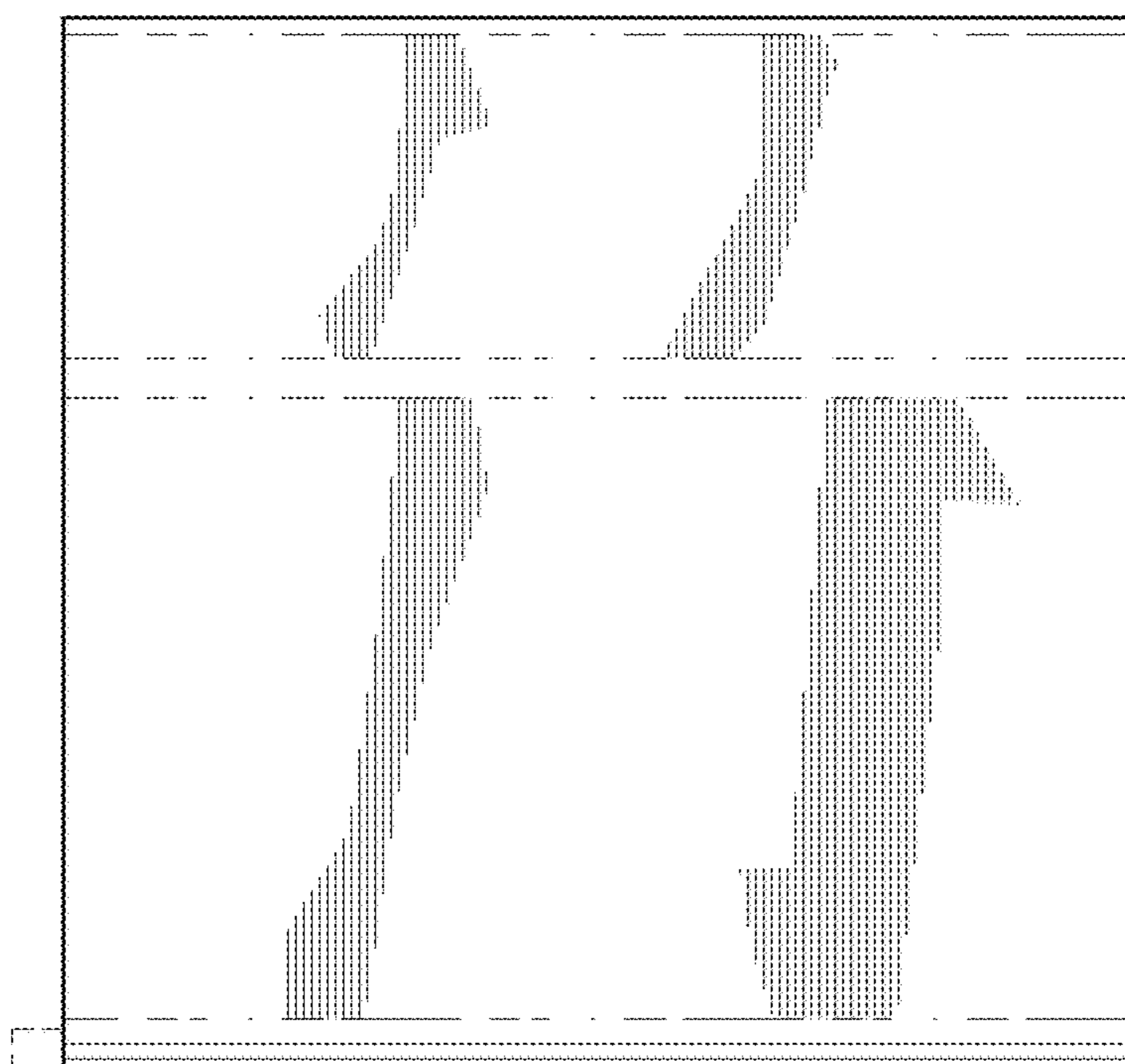

Fig. 7



Fig. 8

