



US00D806232S

(12) **United States Design Patent** (10) **Patent No.:** **US D806,232 S**
Hwang et al. (45) **Date of Patent:** **** Dec. 26, 2017**

(54) **DRUG DELIVERY DEVICE WITH INSERTION MECHANISM**

- (71) Applicant: **Becton, Dickinson and Company**, Franklin Lakes, NJ (US)
- (72) Inventors: **Charles George Hwang**, Wellesley, MA (US); **John Prudden**, Manchester, MA (US); **Russell Cole**, River Vale, NJ (US); **Andrew Allegretti**, Edgewater, NJ (US); **Jeffrey Reed**, Minden, NE (US); **Alessandro Pizzochero**, Chelmsford, MA (US); **J. Richard Gyory**, Sudbury, MA (US); **Justin Cumming**, Arlington, MA (US); **Kurt Maw**, Salem, MA (US)
- (73) Assignee: **Becton, Dickinson and Company**, Franklin Lakes, NJ (US)

(**) Term: **15 Years**

(21) Appl. No.: **29/552,329**

(22) Filed: **Jan. 21, 2016**

(51) **LOC (10) Cl.** **24-02**

(52) **U.S. Cl.**
USPC **D24/112**

(58) **Field of Classification Search**
USPC D24/112–114, 133, 186, 104, 130, 127,
D24/176, 108, 110, 220; 606/181, 185;
(Continued)

(56) **References Cited**

U.S. PATENT DOCUMENTS

D370,011 S * 5/1996 Lindeman D14/137
5,665,065 A 9/1997 Colman et al.
(Continued)

FOREIGN PATENT DOCUMENTS

CN 101801438 B 8/2013
CN 103394143 A 11/2013
(Continued)

OTHER PUBLICATIONS

PAQ®, a Simple 3-Day Basal/Bolus Insulin Delivery Device, for People with Type 2 Diabetes, CeQur Corporation, Abstract from ATTD 2016, 9th International Conference on Advanced Technologies & Treatments for Diabetes, Milan, Italy—Feb. 3-6, 2016, 1 page.

(Continued)

Primary Examiner — David G Muller

Assistant Examiner — Nathan M Johnston

(74) *Attorney, Agent, or Firm* — Dickinson Wright PLLC

(57) **CLAIM**

The ornamental design for a drug delivery device with insertion mechanism, as shown and described.

DESCRIPTION

FIG. 1 is a top perspective view of drug delivery device with insertion mechanism in a first position showing our new design;

FIG. 2 is a bottom perspective view thereof;

FIG. 3 is a top plan view thereof;

FIG. 4 is a left side elevational view thereof;

FIG. 5 is a right side elevational view thereof;

FIG. 6 is a front elevational view thereof;

FIG. 7 is a back elevational view thereof;

FIG. 8 is a bottom plan view thereof;

FIG. 9 is a top perspective view thereof;

FIG. 10 is a bottom perspective view thereof;

FIG. 11 is a top plan view thereof;

FIG. 12 is a left side elevational view thereof;

FIG. 13 is a right side elevational view thereof;

FIG. 14 is a front elevational view thereof;

FIG. 15 is a back elevational view thereof; and,

FIG. 16 is a bottom plan view thereof.

The broken line showing of the drug delivery device with insertion mechanism is included for the purpose of illustrating portions of the “article” and forms no part of the claimed design.

1 Claim, 12 Drawing Sheets

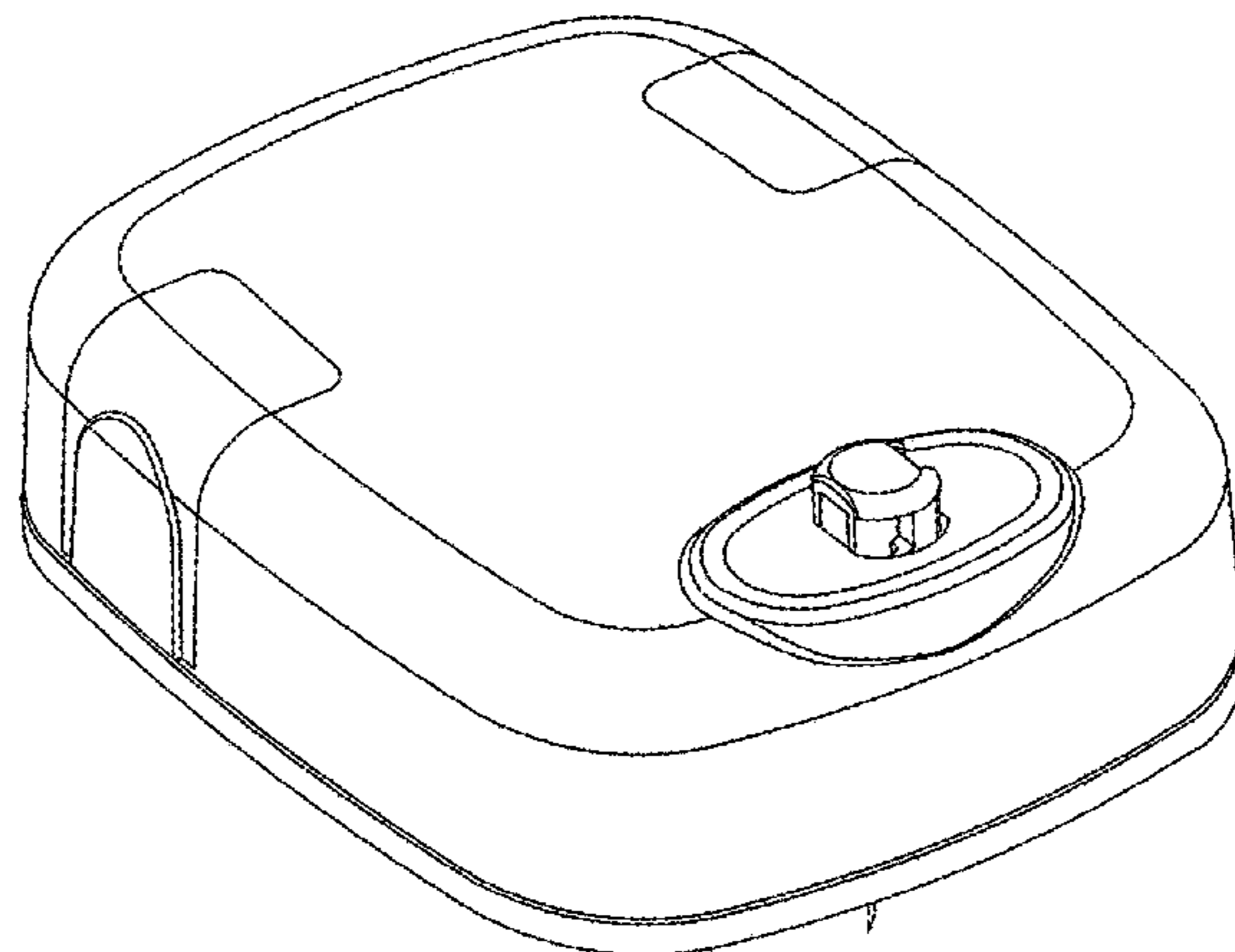

(58) **Field of Classification Search**
 USPC .. 604/232, 187, 158, 164.08, 192, 263, 163,
 604/181, 184, 198, 227, 168.01, 275,
 604/890.1; D9/414, 424, 417, 426
 CPC A61M 2005/14252; A61M 2005/1581;
 A61M 5/14248; A61M 2005/14513;
 A61M 2005/206
 See application file for complete search history.

(56) **References Cited**

U.S. PATENT DOCUMENTS

D389,139 S * 1/1998 Oross D14/137
 5,816,779 A 10/1998 Lawless et al.
 5,913,180 A 6/1999 Ryan
 6,006,239 A 12/1999 Bhansali et al.
 D445,496 S * 7/2001 Anderson D24/110
 6,589,229 B1 7/2003 Connelly et al.
 6,656,147 B1 12/2003 Gertsek et al.
 6,656,148 B2 12/2003 Das et al.
 6,685,675 B1 2/2004 Hadvary et al.
 6,740,059 B2 5/2004 Flaherty
 D495,303 S * 8/2004 Coullahan D13/168
 6,824,529 B2 11/2004 Gross et al.
 6,843,782 B2 1/2005 Gross et al.
 7,052,251 B2 5/2006 Nason et al.
 D544,092 S * 6/2007 Lewis D24/108
 D564,087 S 3/2008 Yodfat et al.
 D574,016 S 7/2008 Yodfat et al.
 D577,118 S 9/2008 Yodfat et al.
 7,517,440 B2 4/2009 Anex et al.
 7,648,494 B2 1/2010 Kornerup et al.
 7,678,079 B2 3/2010 Shermer et al.
 7,708,717 B2 5/2010 Estes et al.
 D622,685 S * 8/2010 Garra D14/137
 7,771,391 B2 8/2010 Carter
 7,802,923 B2 9/2010 Arnold et al.
 7,857,131 B2 12/2010 Vedrine
 7,922,708 B2 4/2011 Estes et al.
 7,927,306 B2 4/2011 Cross et al.
 7,931,621 B2 4/2011 Cross et al.
 7,938,801 B2 5/2011 Hawkins et al.
 7,976,493 B2 * 7/2011 Carter A61M 5/14244
 604/67
 7,976,500 B2 7/2011 Adams et al.
 8,062,253 B2 11/2011 Nielsen et al.
 8,062,256 B2 11/2011 Carter et al.
 8,114,064 B2 2/2012 Alferness et al.
 8,128,596 B2 3/2012 Carter
 8,128,597 B2 3/2012 Cross et al.
 8,162,923 B2 4/2012 Adams et al.
 8,210,172 B2 * 7/2012 Crowder A61M 15/0045
 128/200.24
 8,226,606 B2 7/2012 Adams et al.
 8,226,607 B2 7/2012 Carter et al.
 8,231,572 B2 7/2012 Carter et al.
 8,231,577 B2 7/2012 Carter et al.
 8,267,921 B2 9/2012 Yodfat et al.
 8,337,486 B2 12/2012 Yodfat et al.
 8,352,041 B2 1/2013 Das et al.
 8,361,030 B2 1/2013 Carter
 8,409,151 B2 4/2013 Hawkins et al.
 8,414,563 B2 4/2013 Kamen et al.
 8,449,504 B2 5/2013 Carter et al.
 D684,685 S 6/2013 Schneider et al.
 D684,686 S 6/2013 Cronenberg
 D685,083 S 6/2013 Schneider et al.
 D685,084 S 6/2013 Guarraia et al.
 8,469,920 B2 6/2013 Mernoe et al.
 D687,140 S 7/2013 Guarraia et al.
 D687,141 S 7/2013 Schneider et al.
 8,491,529 B2 7/2013 Yodfat et al.
 D687,536 S 8/2013 Guarraia et al.
 D688,784 S 8/2013 Schneider et al.
 8,500,692 B2 8/2013 Yodfat et al.
 8,512,287 B2 8/2013 Cindrich et al.

8,613,719 B2 12/2013 Karratt et al.
 8,753,310 B2 6/2014 Sullivan et al.
 8,753,315 B2 6/2014 Alferness et al.
 8,758,308 B2 6/2014 Alferness et al.
 8,795,230 B2 8/2014 Schoonmaker et al.
 8,795,234 B2 8/2014 Kadamus et al.
 8,808,269 B2 8/2014 Bazargan et al.
 D714,266 S * 9/2014 Okamura D14/191
 D747,456 S 1/2016 Sonderegger et al.
 D747,457 S 1/2016 Glace et al.
 D747,458 S 1/2016 Sonderegger et al.
 D747,459 S 1/2016 Sonderegger et al.
 9,254,373 B2 2/2016 Hørdum
 D754,842 S 4/2016 Sonderegger et al.
 D754,843 S 4/2016 Sonderegger et al.
 D756,504 S 5/2016 Sonderegger et al.
 9,364,606 B2 6/2016 Cindrich et al.
 9,433,757 B2 9/2016 Constantineau et al.
 D769,438 S * 10/2016 Crosby D24/110
 9,480,792 B2 11/2016 Constantineau et al.
 9,522,229 B2 12/2016 Sonderegger et al.
 9,522,231 B2 12/2016 Schneider et al.
 2005/0238507 A1 10/2005 DiIanni et al.
 2006/0183984 A1 8/2006 Dobbles et al.
 2007/0282269 A1 12/2007 Carter et al.
 2007/0287960 A1 12/2007 Adams et al.
 2007/0299408 A1 12/2007 Alferness et al.
 2008/0119790 A1 5/2008 Hawkins et al.
 2008/0167641 A1 7/2008 Hansen et al.
 2008/0249473 A1 10/2008 Rutti et al.
 2009/0088692 A1 4/2009 Adams et al.
 2009/0182277 A1 7/2009 Carter
 2009/0240240 A1 9/2009 Hines et al.
 2009/0247982 A1 10/2009 Krulevitch et al.
 2009/0254041 A1 * 10/2009 Krag A61M 5/14224
 604/180
 2009/0281497 A1 11/2009 Kamen et al.
 2010/0049128 A1 2/2010 McKenzie et al.
 2010/0167385 A1 7/2010 Celentano et al.
 2010/0204657 A1 8/2010 Yodfat et al.
 2010/0234805 A1 9/2010 Kaufmann et al.
 2011/0098652 A1 4/2011 Hasted et al.
 2011/0282293 A1 11/2011 Hørdum
 2011/0306931 A1 12/2011 Kamen et al.
 2011/0319862 A1 12/2011 Friedman et al.
 2012/0053522 A1 3/2012 Yodfat et al.
 2012/0150115 A1 6/2012 Kamen et al.
 2012/0209241 A1 8/2012 Drew
 2012/0215175 A1 8/2012 Alferness et al.
 2013/0072872 A1 3/2013 Yodfat et al.
 2013/0226092 A1 8/2013 Hawkins et al.
 2014/0088504 A1 3/2014 King
 2014/0148756 A1 5/2014 Yodfat et al.
 2014/0236086 A1 8/2014 Levesque et al.
 2014/0236087 A1 8/2014 Alderete, Jr. et al.
 2015/0065959 A1 3/2015 Carter et al.
 2015/0250943 A1 * 9/2015 Momose A61M 5/14276
 604/151
 2015/0292779 A1 10/2015 Chen
 2015/0306307 A1 * 10/2015 Cole A61M 5/14248
 604/508

FOREIGN PATENT DOCUMENTS

WO WO-2009013736 A1 1/2009
 WO WO-2009045780 A2 4/2009
 WO WO-2009117466 A1 9/2009
 WO WO-2015199981 A1 12/2015

OTHER PUBLICATIONS

Human Factor Testing Provided Valuable Input into the Iterative Optimization of PAQ®, CeQur Corporation, Abstract from ATTD 2016, 9th International Conference on Advanced Technologies & Treatments for Diabetes, Milan, Italy—Feb. 3-6, 2016, 1 page.
 Validation of Adhesive Tape Optimization of PAQ®, a Simple 3-Day Wearable Basal/Bolus Insulin Delivery Device, in Normal

(56)

References Cited

OTHER PUBLICATIONS

Volunteers, CeQur Corporation, Abstract from ATTD 2016, 9th International Conference on Advanced Technologies & Treatments for Diabetes, Milan, Italy—Feb. 3-6, 2016, 1 page.

PAQ®, a Simple 3-Day Wearable Basal/Bolus Insulin Delivery Device, Designed for Discreet Diabetes Management, CeQur Corporation, Abstract from Attd 2016, 9th International Conference on Advanced Technologies & Treatments for Diabetes, Milan, Italy—Feb. 3-6, 2016, 1 page.

* cited by examiner

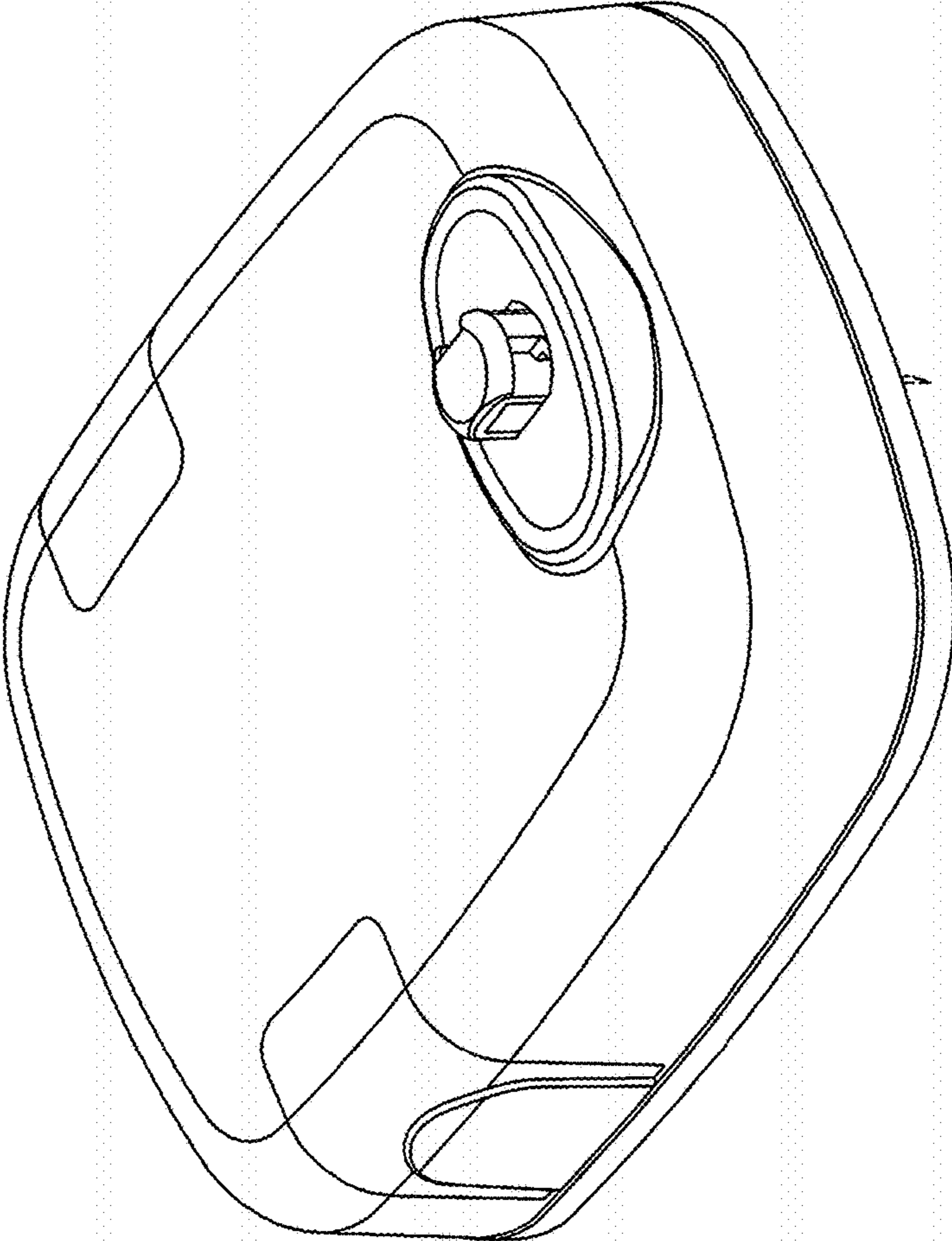

FIG.1

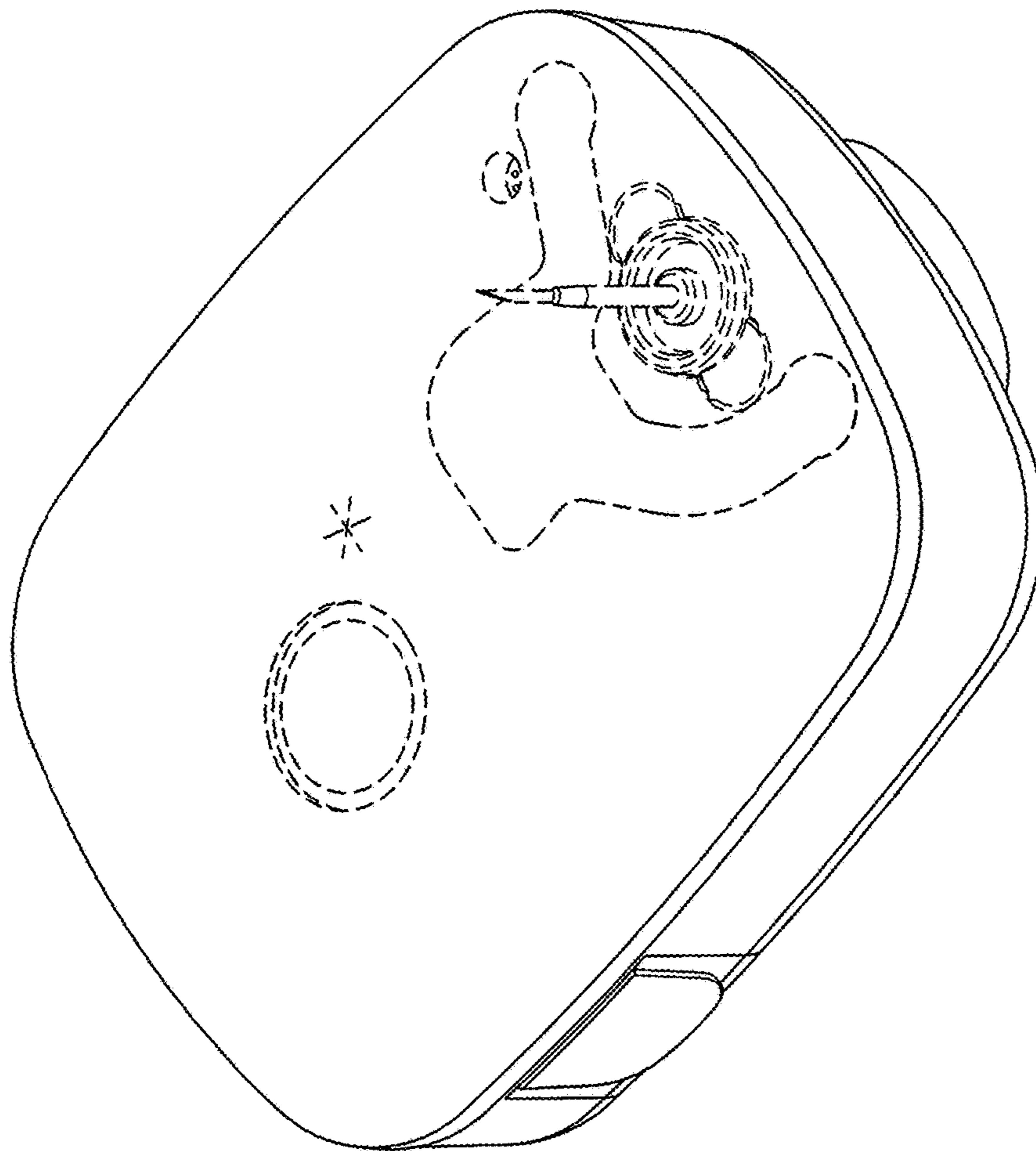

FIG.2

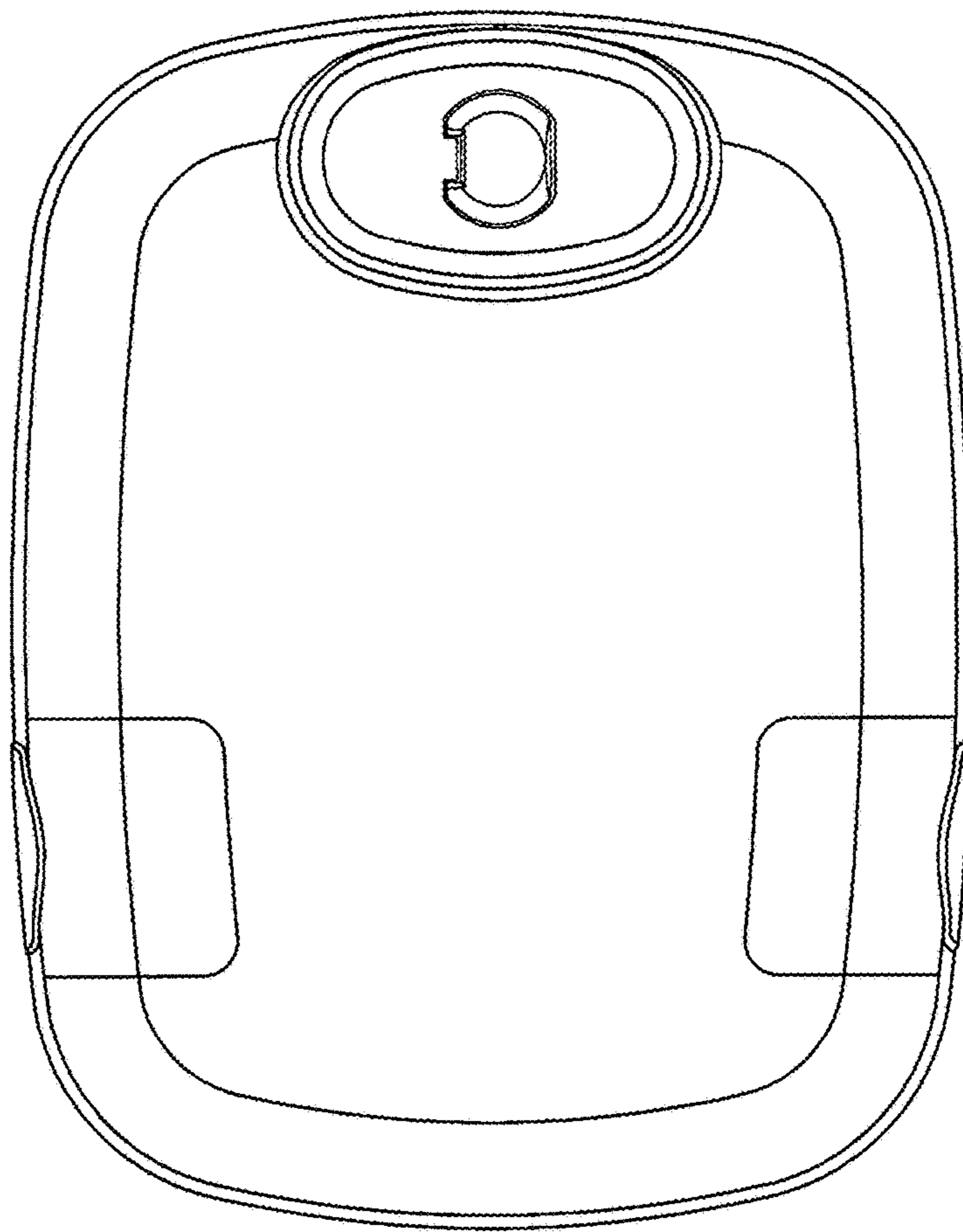

FIG.3

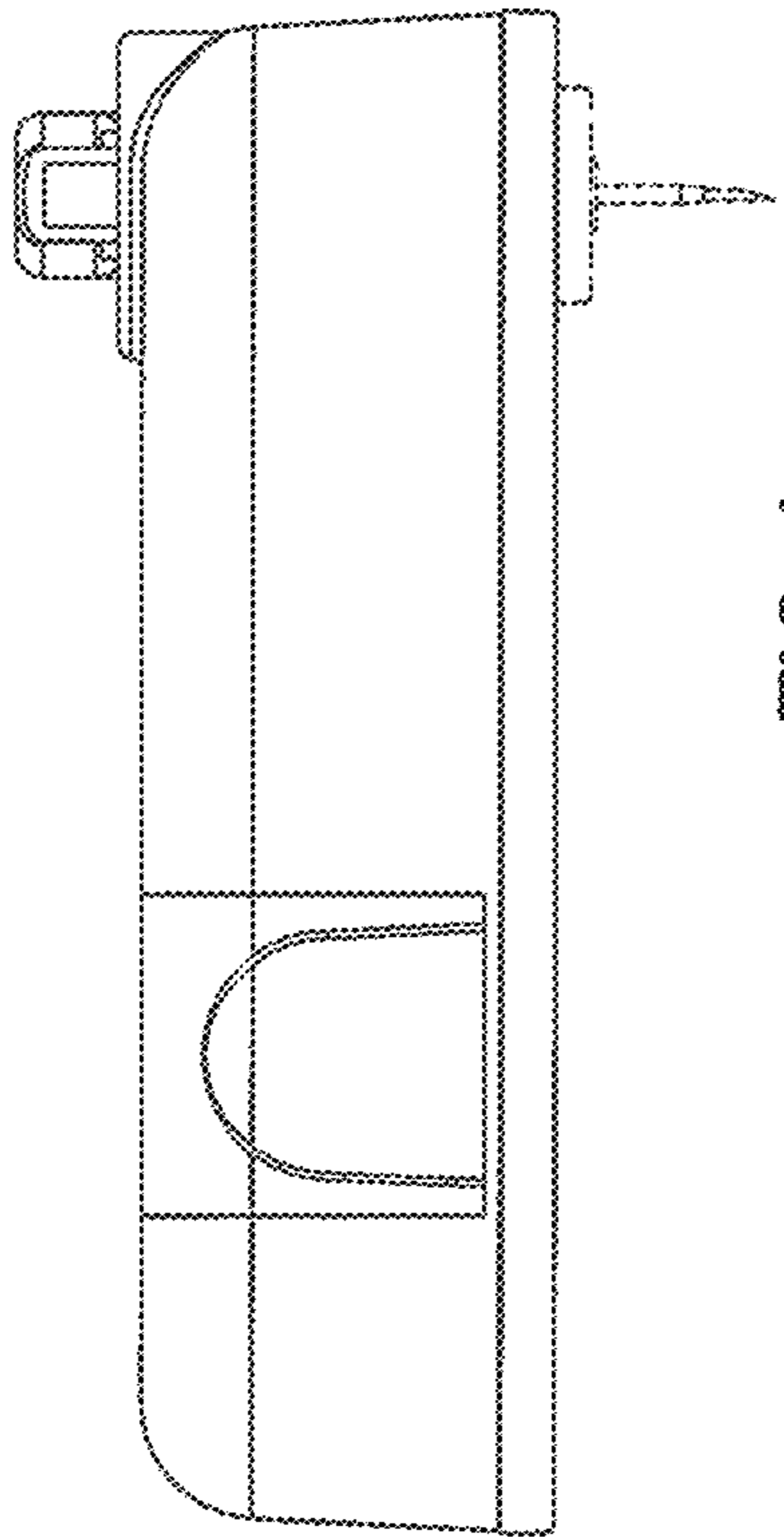

FIG. 4

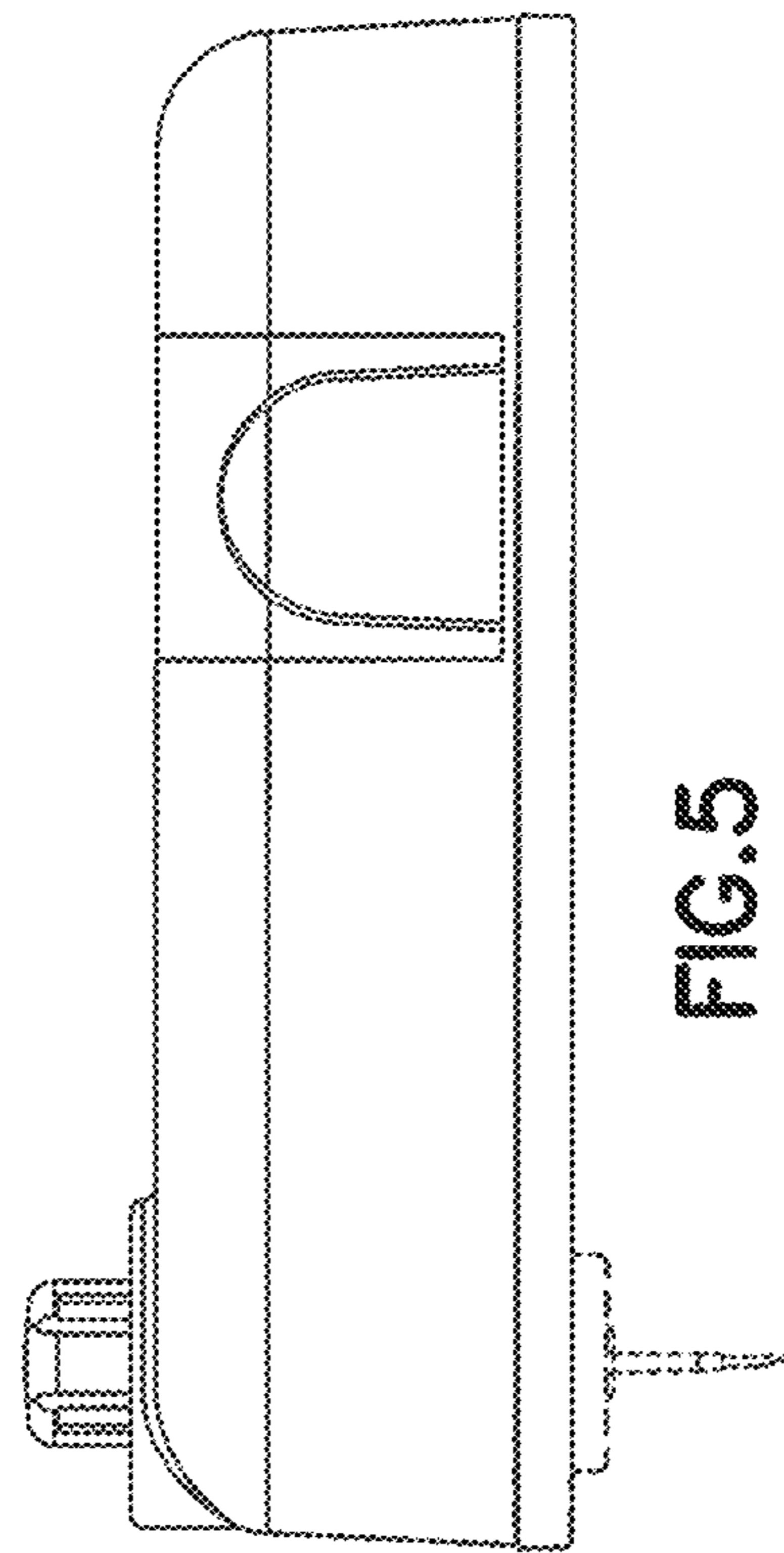

FIG. 5

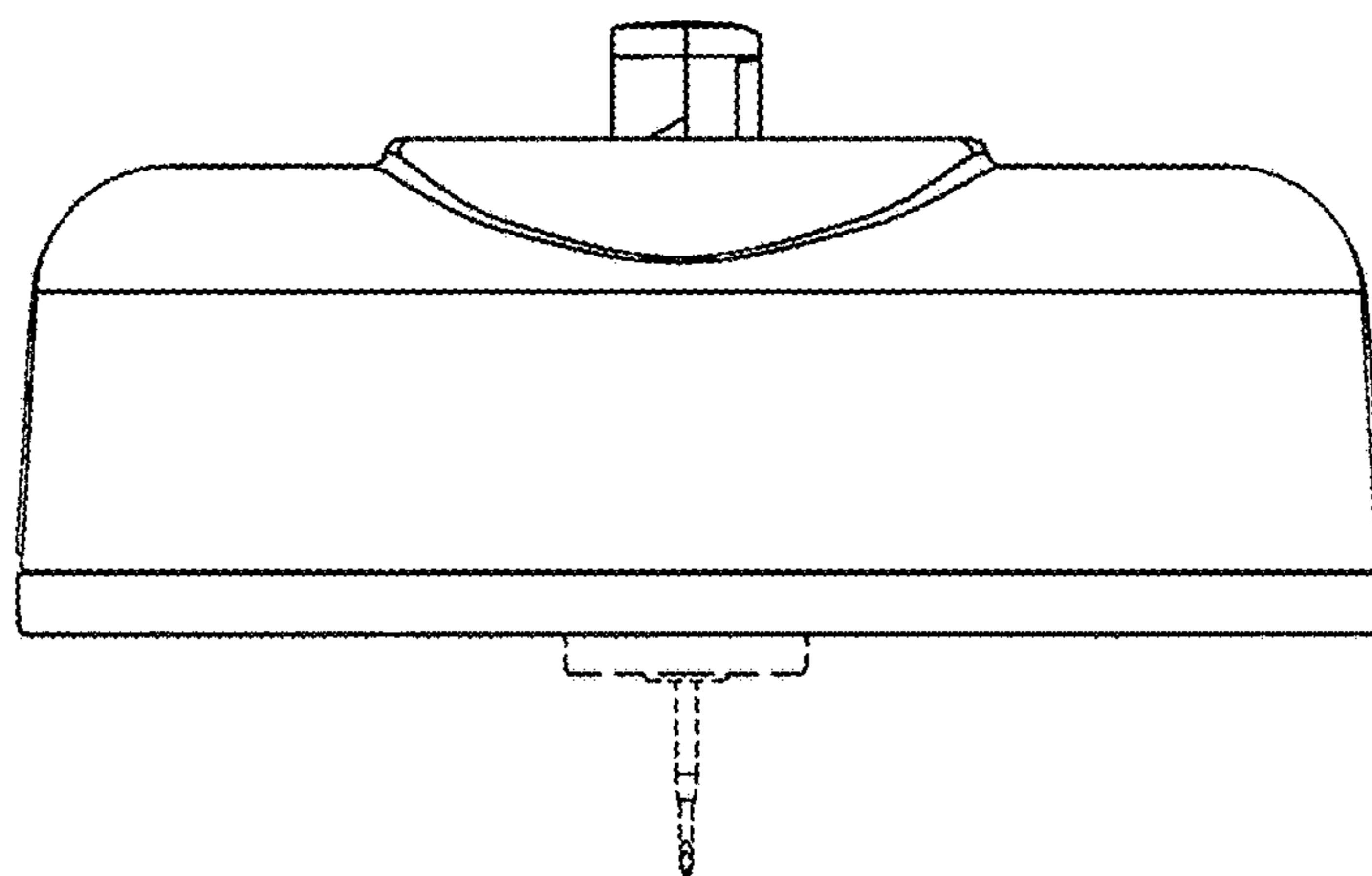

FIG. 6

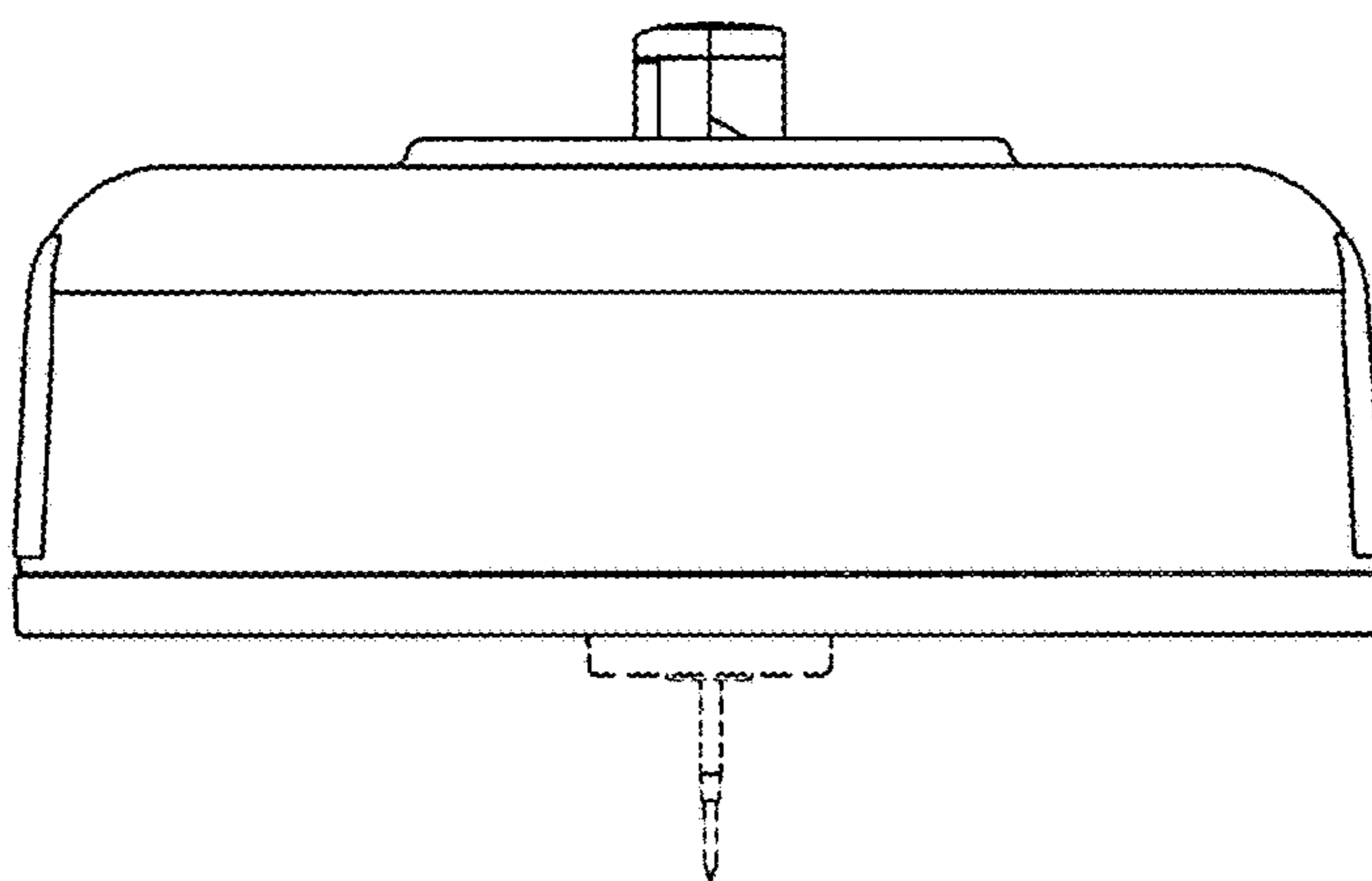

FIG. 7

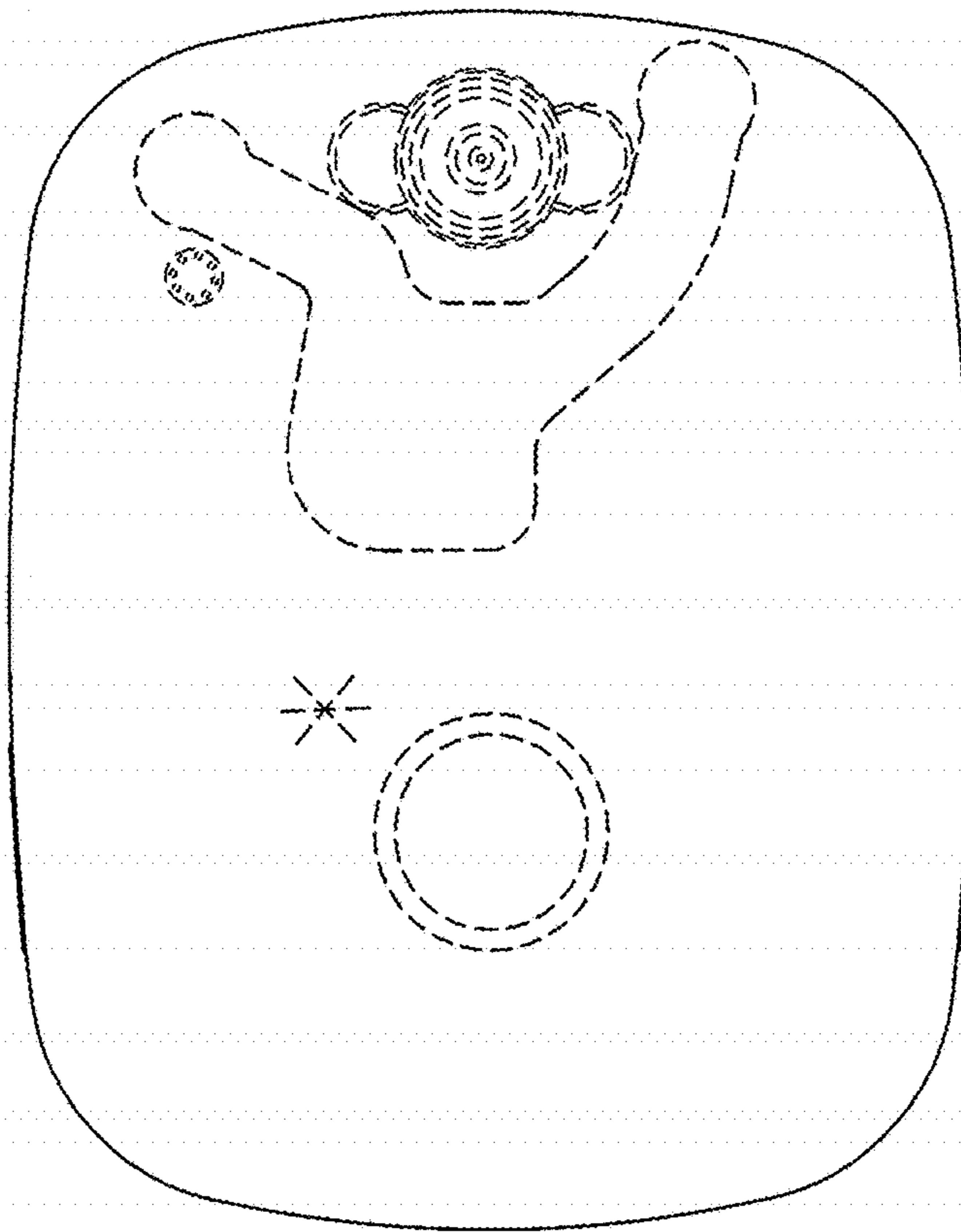

FIG. 8

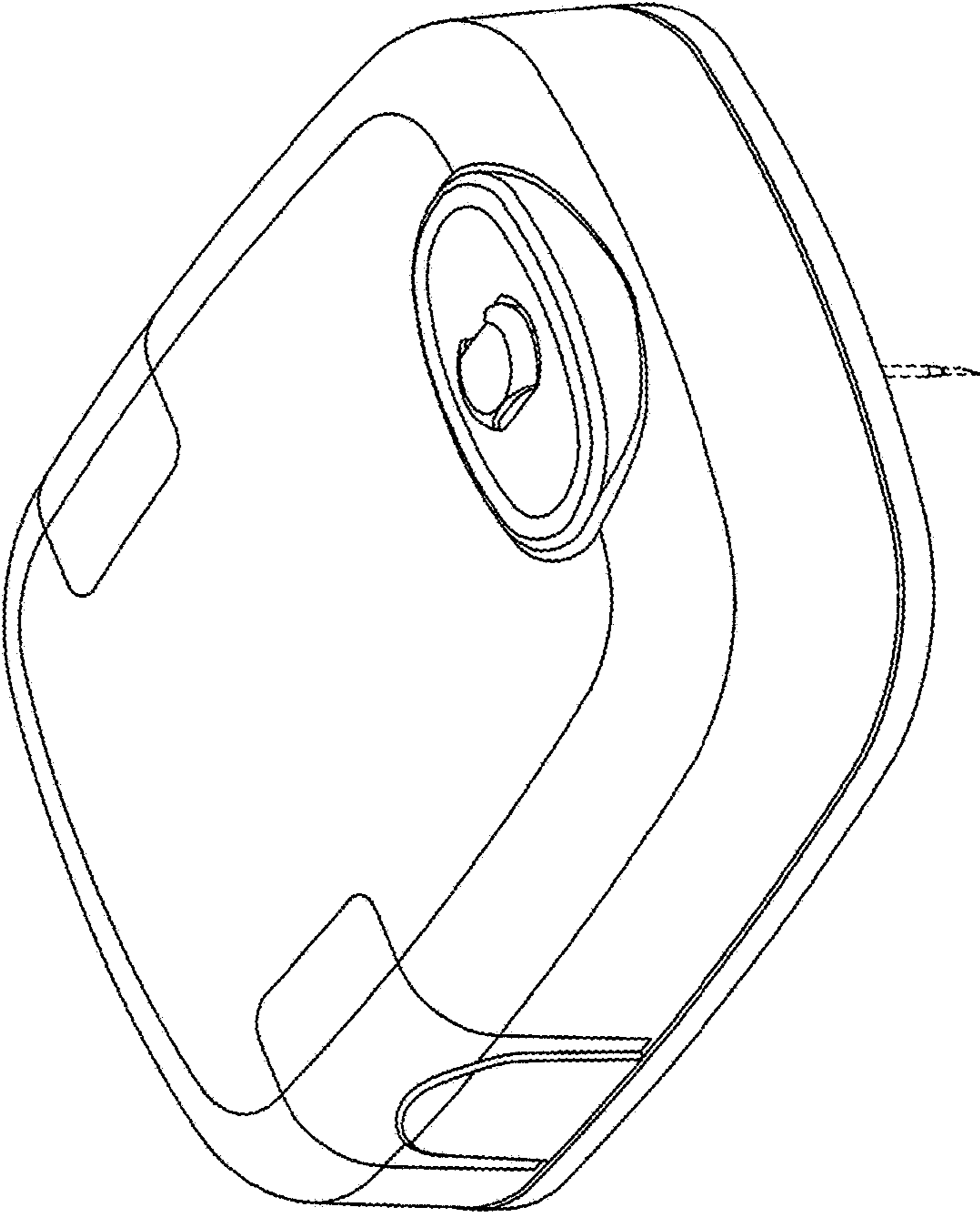

FIG.9

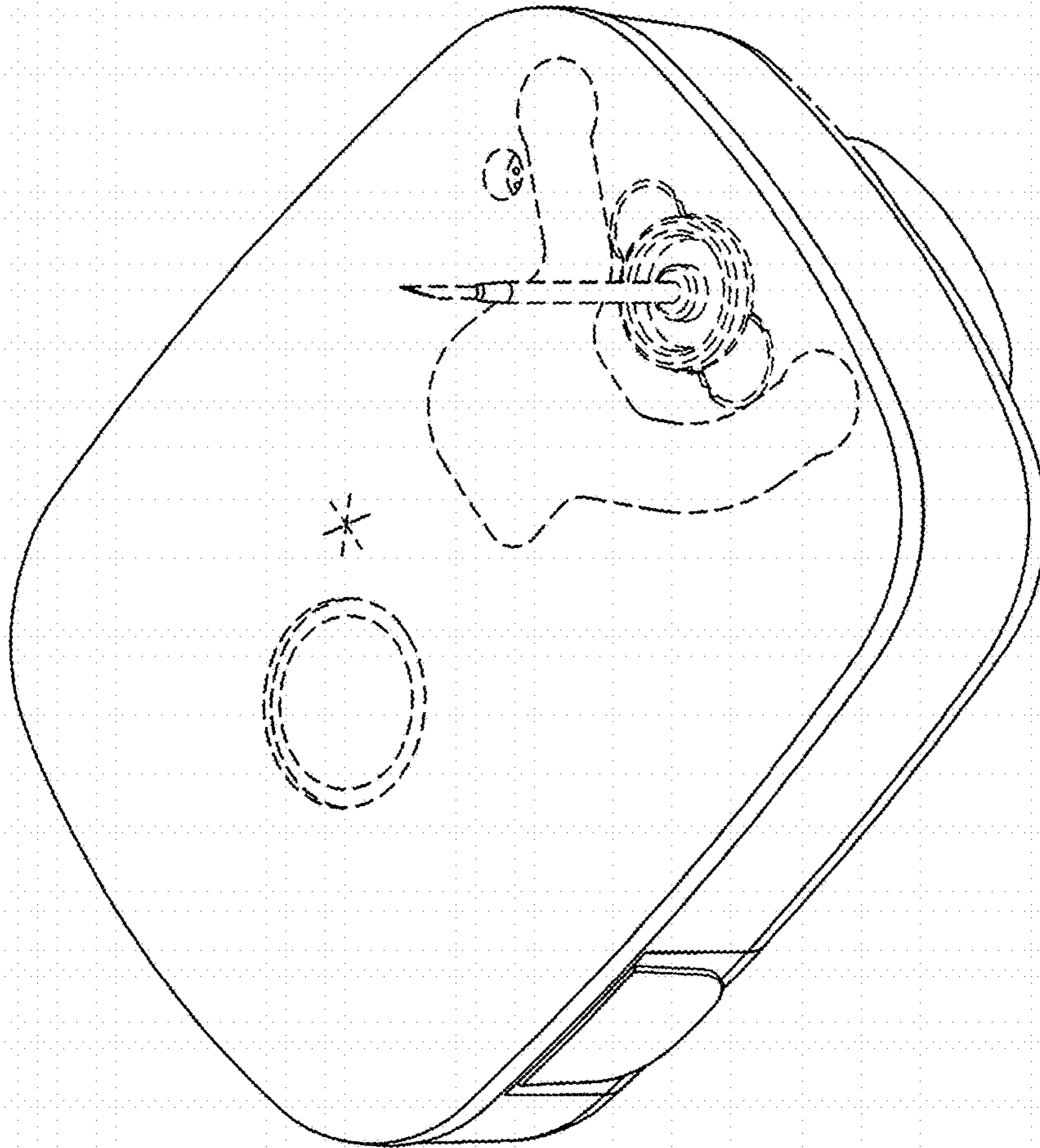

FIG. 10

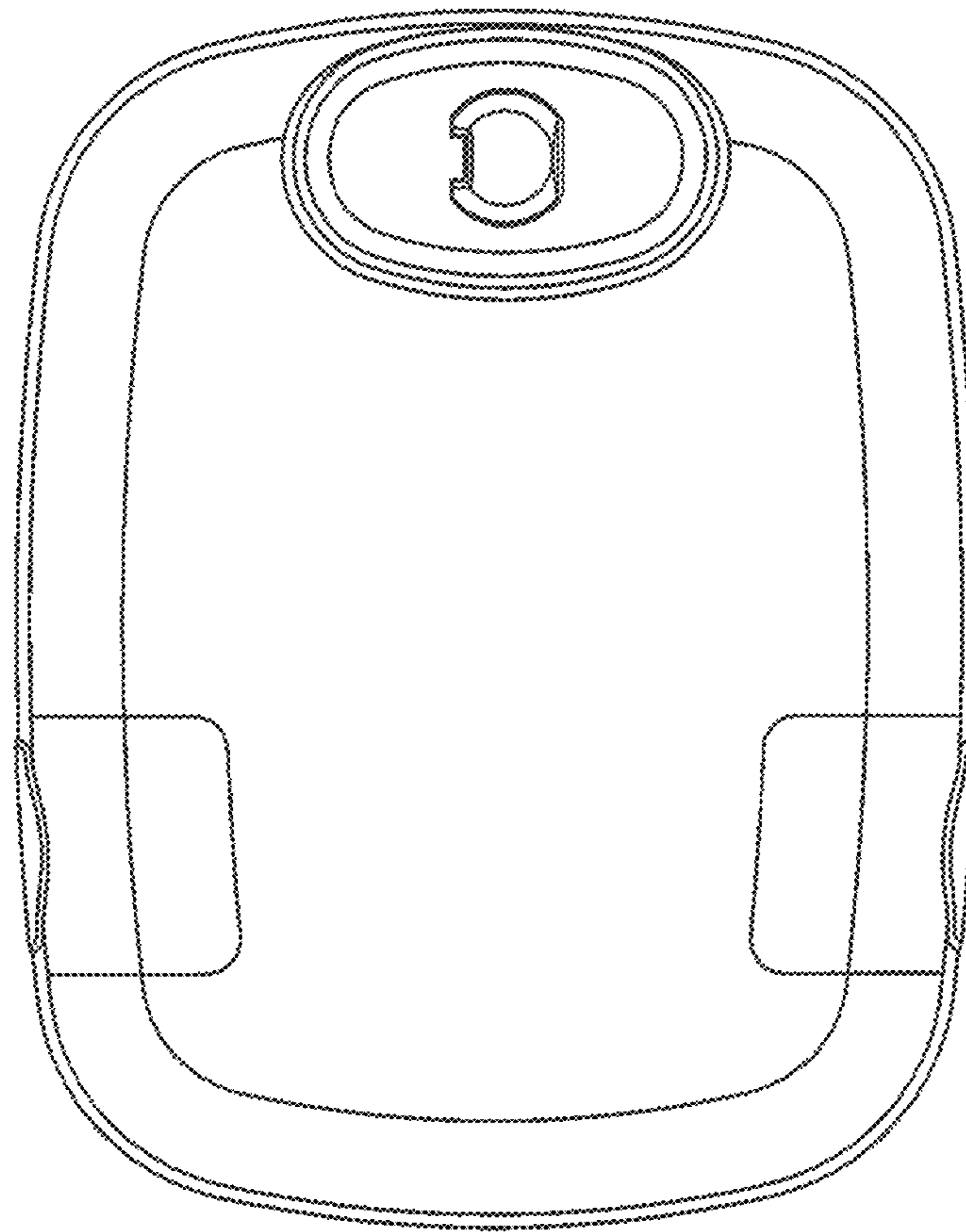

FIG. 11

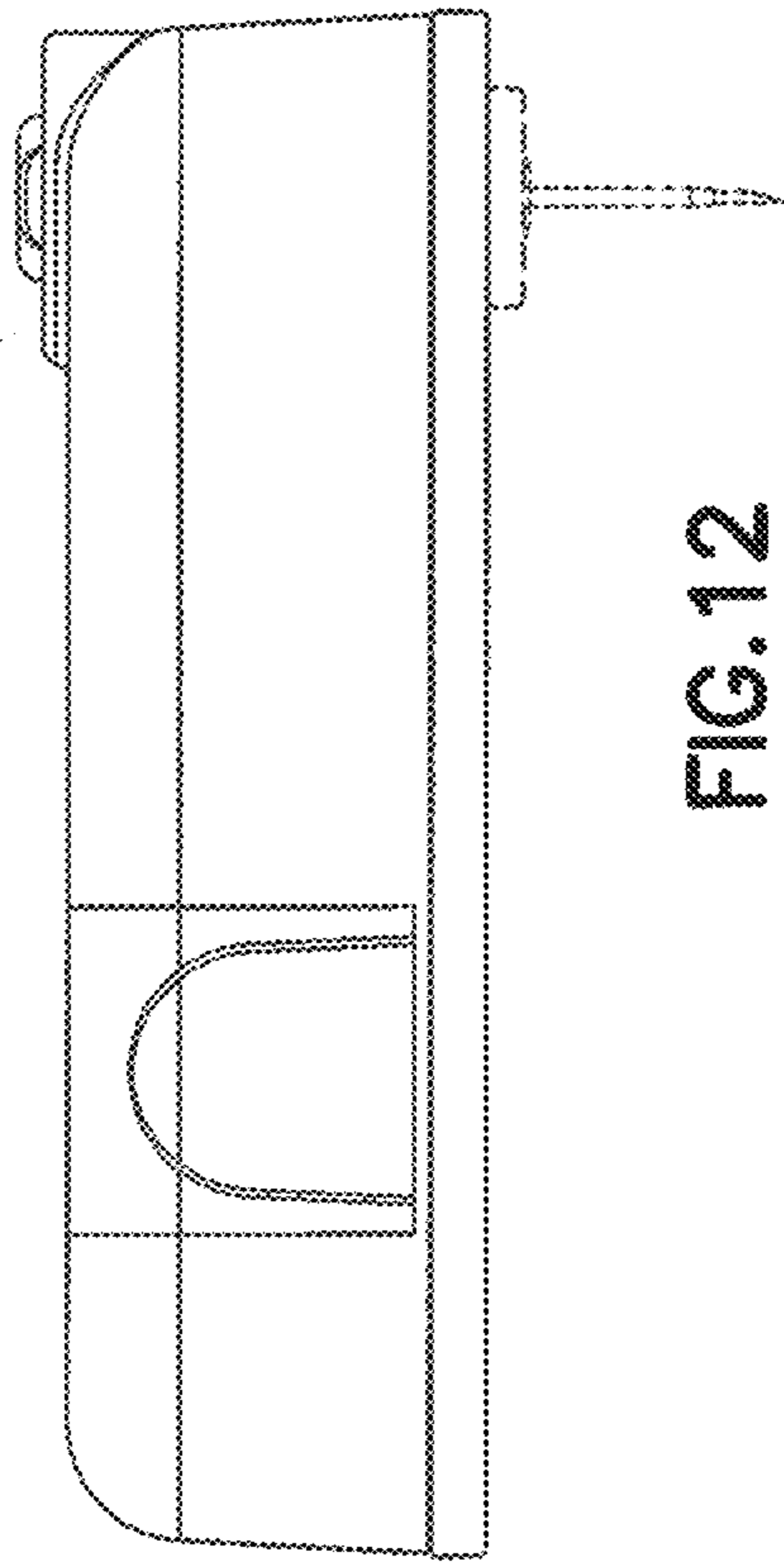

FIG. 12

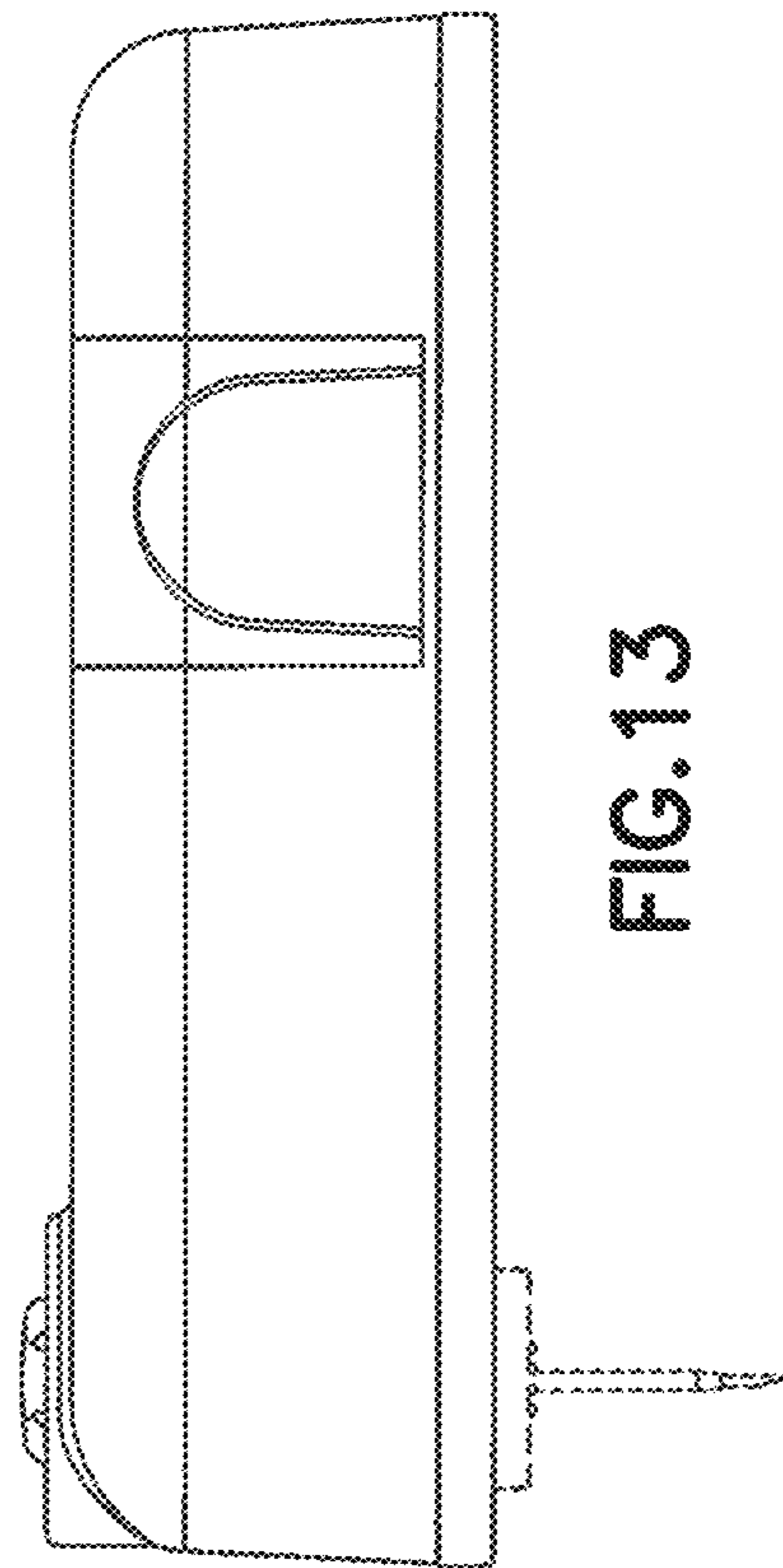

FIG. 13

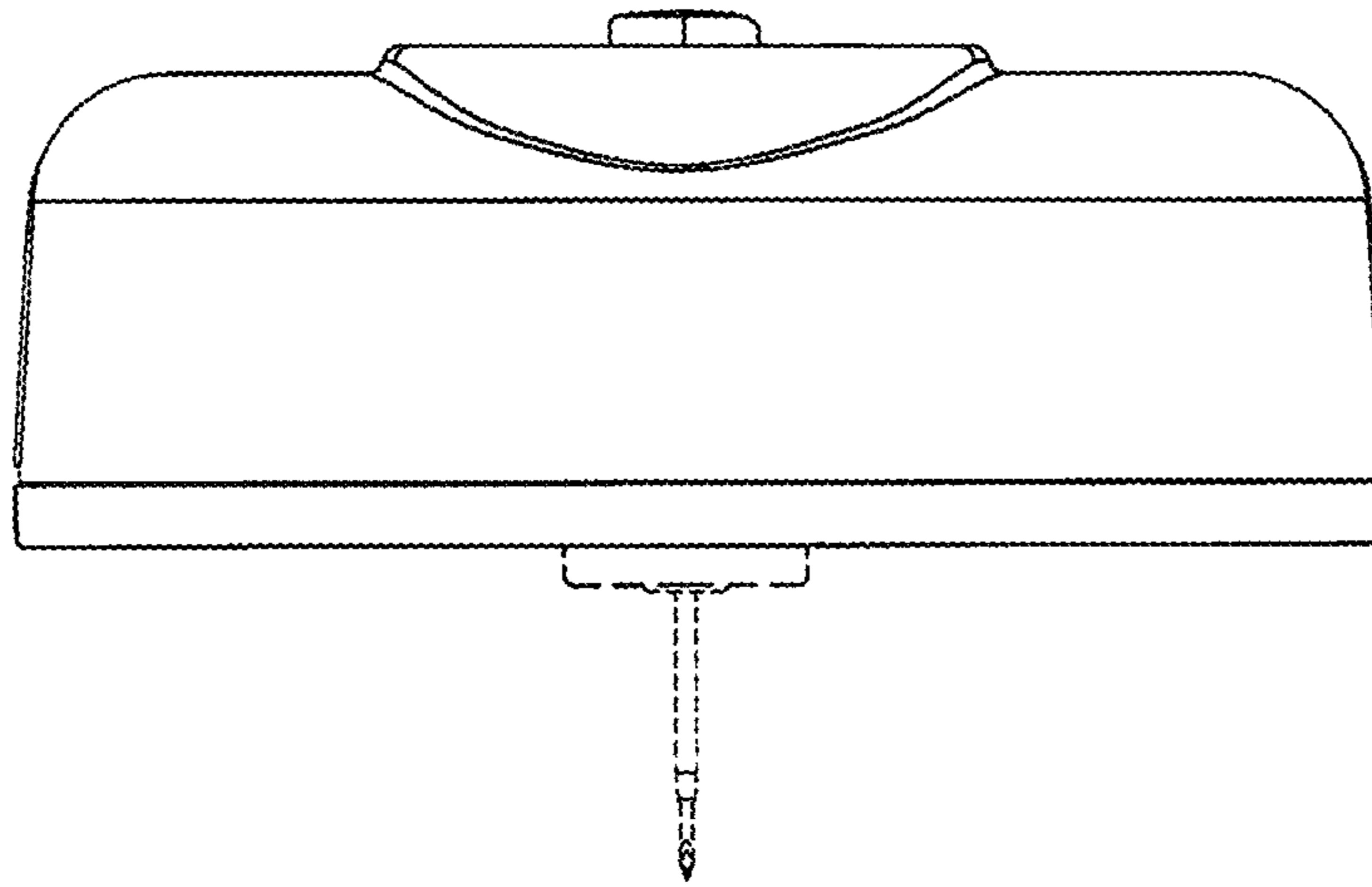

FIG. 14

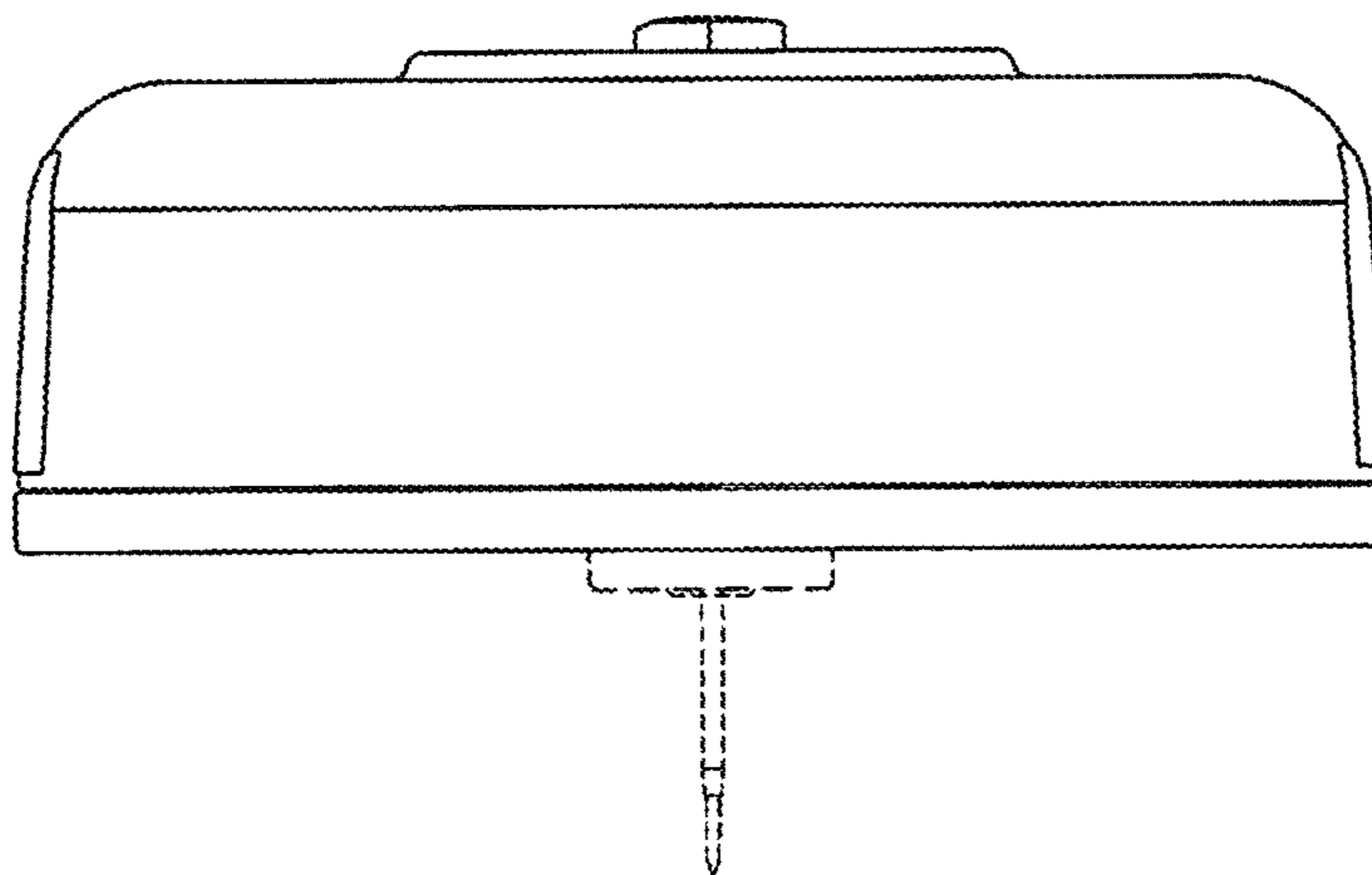

FIG. 15

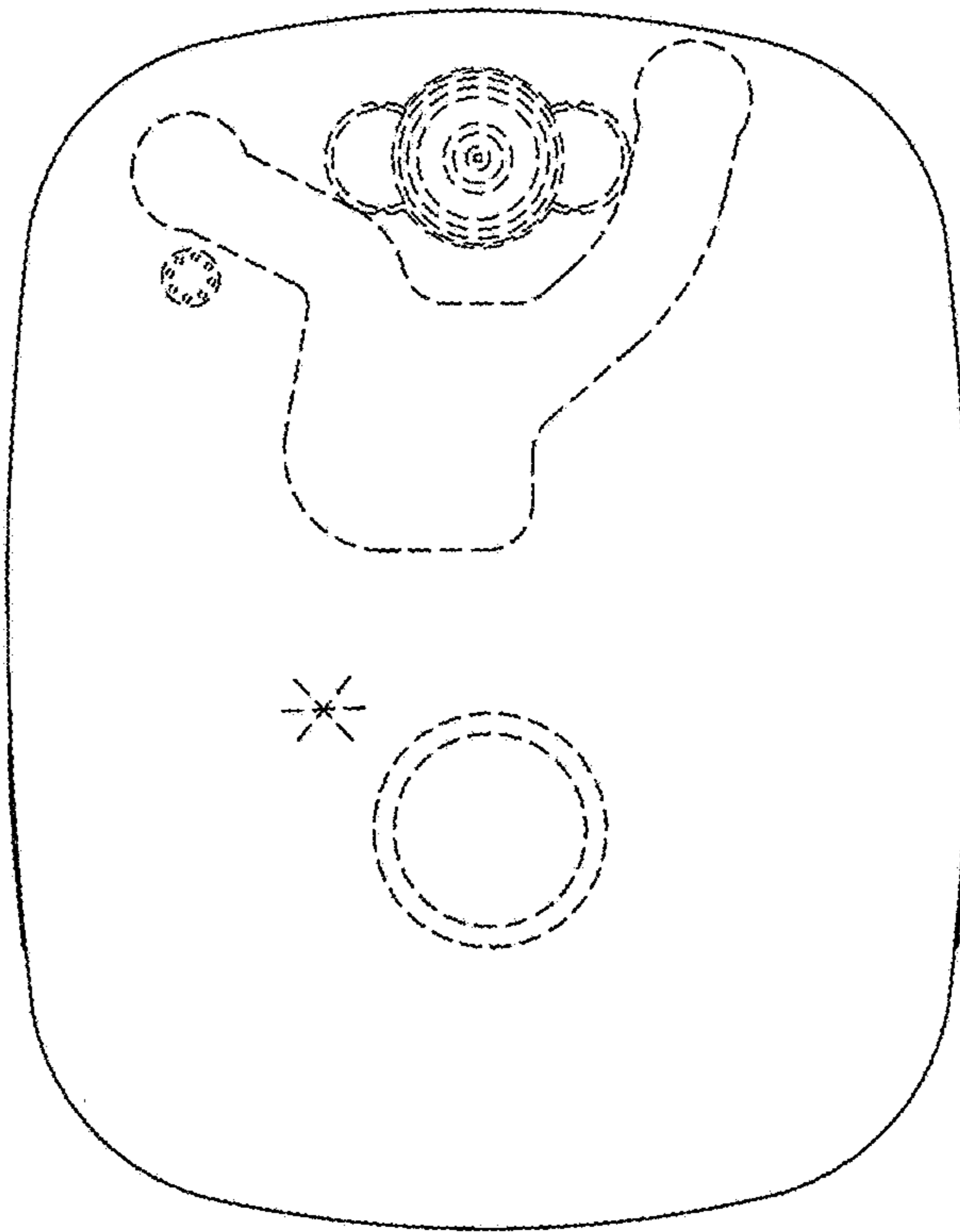

FIG. 16