



US00D806153S

(12) **United States Design Patent**
Skov

(10) **Patent No.:** **US D806,153 S**

(45) **Date of Patent:** **** Dec. 26, 2017**

(54) **LINEAR ACTUATOR**

(71) Applicant: **LINAK A/S**, Nordborg (DK)

(72) Inventor: **Bjarne Skov**, Sønderborg (DK)

(73) Assignee: **LINAK A/S**, Nordborg (DK)

(**) Term: **15 Years**

(21) Appl. No.: **29/587,952**

(22) Filed: **Dec. 16, 2016**

(30) **Foreign Application Priority Data**

Jun. 27, 2016 (DK) 2016 00095

(51) **LOC (10) Cl.** **15-09**

(52) **U.S. Cl.**
USPC **D15/148**

(58) **Field of Classification Search**
USPC D12/345; D13/118, 158, 162, 184;
D15/1-5, 7, 9, 138, 140, 143, 148, 149,
D15/199
CPC B66F 3/18; F16H 19/04; F16H 57/039;
H01F 7/066
See application file for complete search history.

(56) **References Cited**

U.S. PATENT DOCUMENTS

D458,284 S * 6/2002 Landerholm D15/143
D577,753 S * 9/2008 Lund D15/143
D589,991 S * 4/2009 Chen D15/143
D656,975 S * 4/2012 Tseng D15/143
D765,748 S * 9/2016 Bogelund D15/143

D776,728 S * 1/2017 Wu D15/143
D785,061 S * 4/2017 Gong D15/148
D785,062 S * 4/2017 Gong D15/148
D792,490 S * 7/2017 Lin D15/143
D792,492 S * 7/2017 Lin D15/143
2011/0100141 A1* 5/2011 Inoue F16H 25/2015
74/25

* cited by examiner

Primary Examiner — Patricia Palasik

(74) *Attorney, Agent, or Firm* — Renner, Otto, Boisselle & Sklar, LLP.

(57) **CLAIM**

The ornamental design for a linear actuator, as shown and described.

DESCRIPTION

FIG. 1 is a top, front, left perspective view of a linear actuator;
FIG. 2 is a bottom, rear, left perspective view of the linear actuator as shown in FIG. 1;
FIG. 3 is a right elevation view of the linear actuator shown in FIG. 1;
FIG. 4 is a left elevation view of the linear actuator shown in FIG. 1;
FIG. 5 is a top plan view of the linear actuator shown in FIG. 1;
FIG. 6 is a bottom plan view of the linear actuator shown in FIG. 1;
FIG. 7 is a front elevation view of the linear actuator shown in FIG. 1; and,
FIG. 8 is a rear elevation view of the linear actuator shown in FIG. 1.

1 Claim, 8 Drawing Sheets

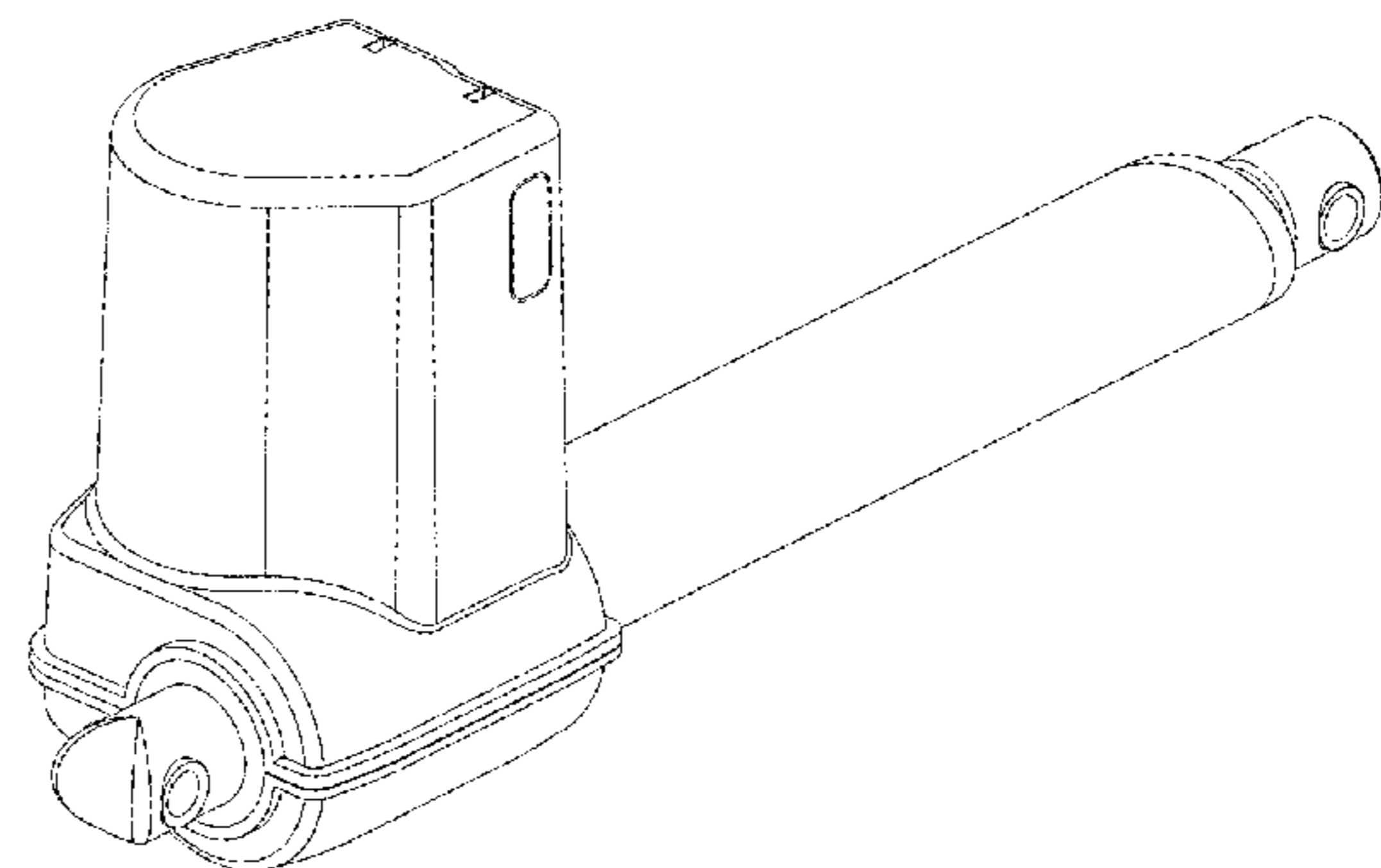
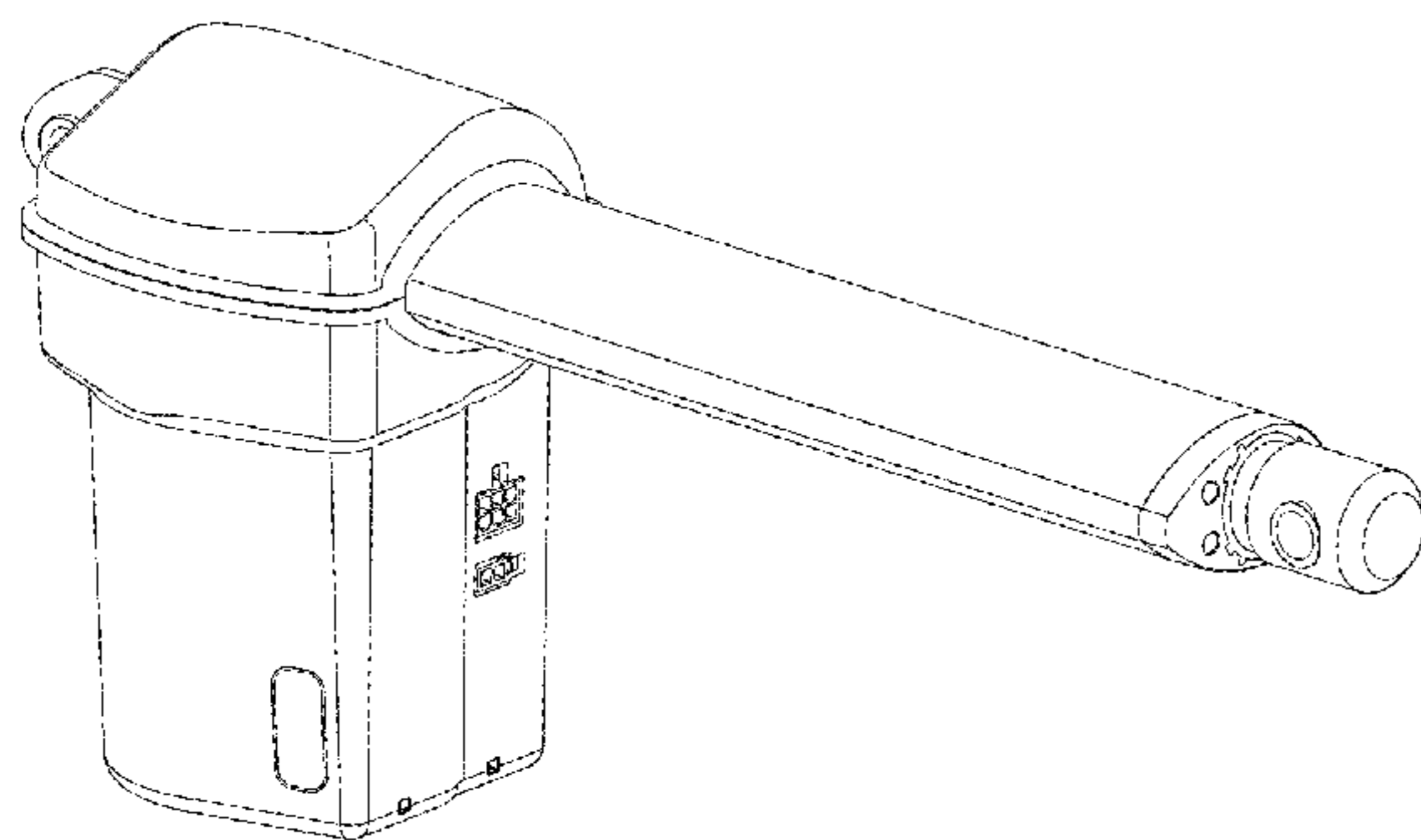

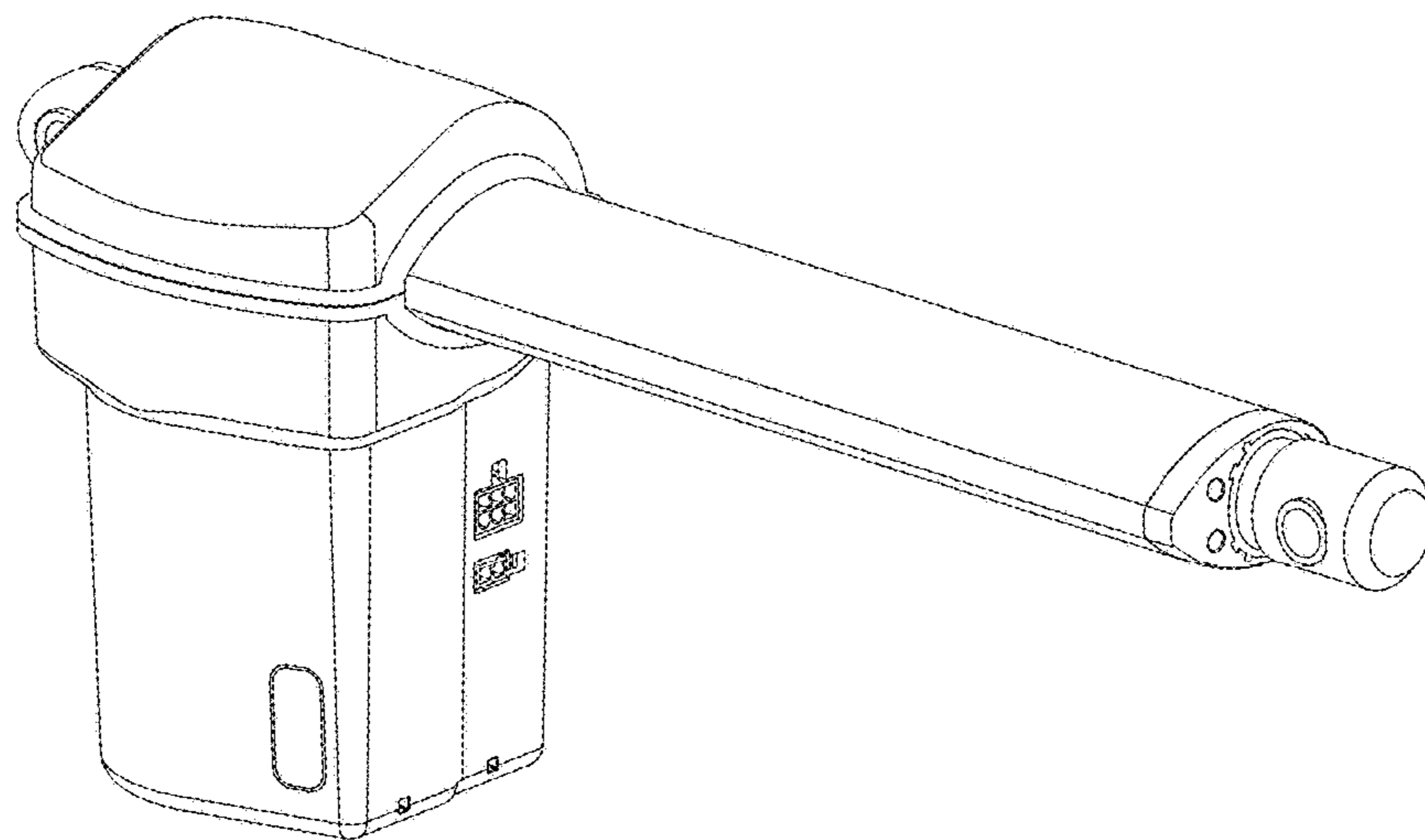

FIG. 1

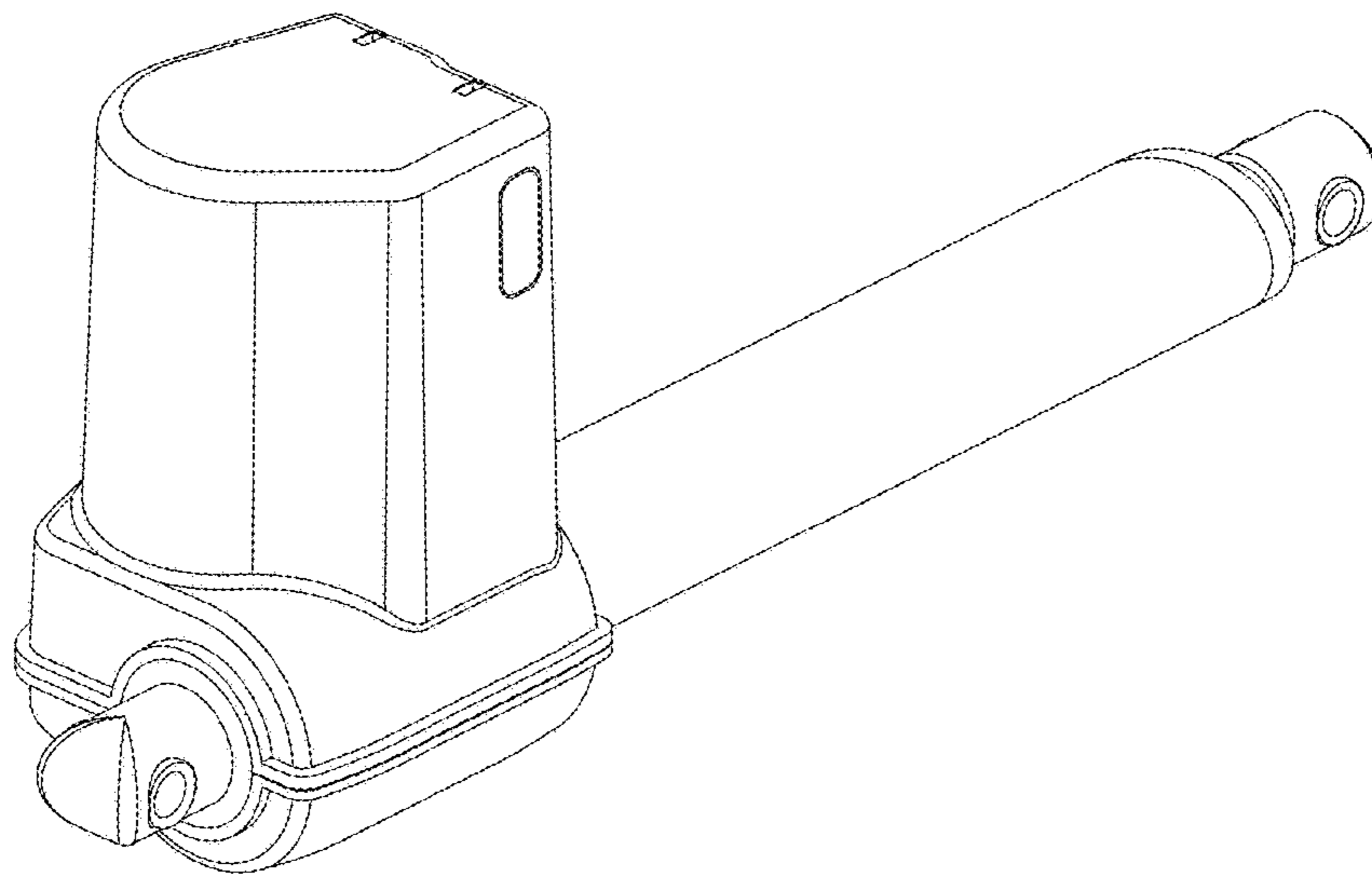

FIG. 2

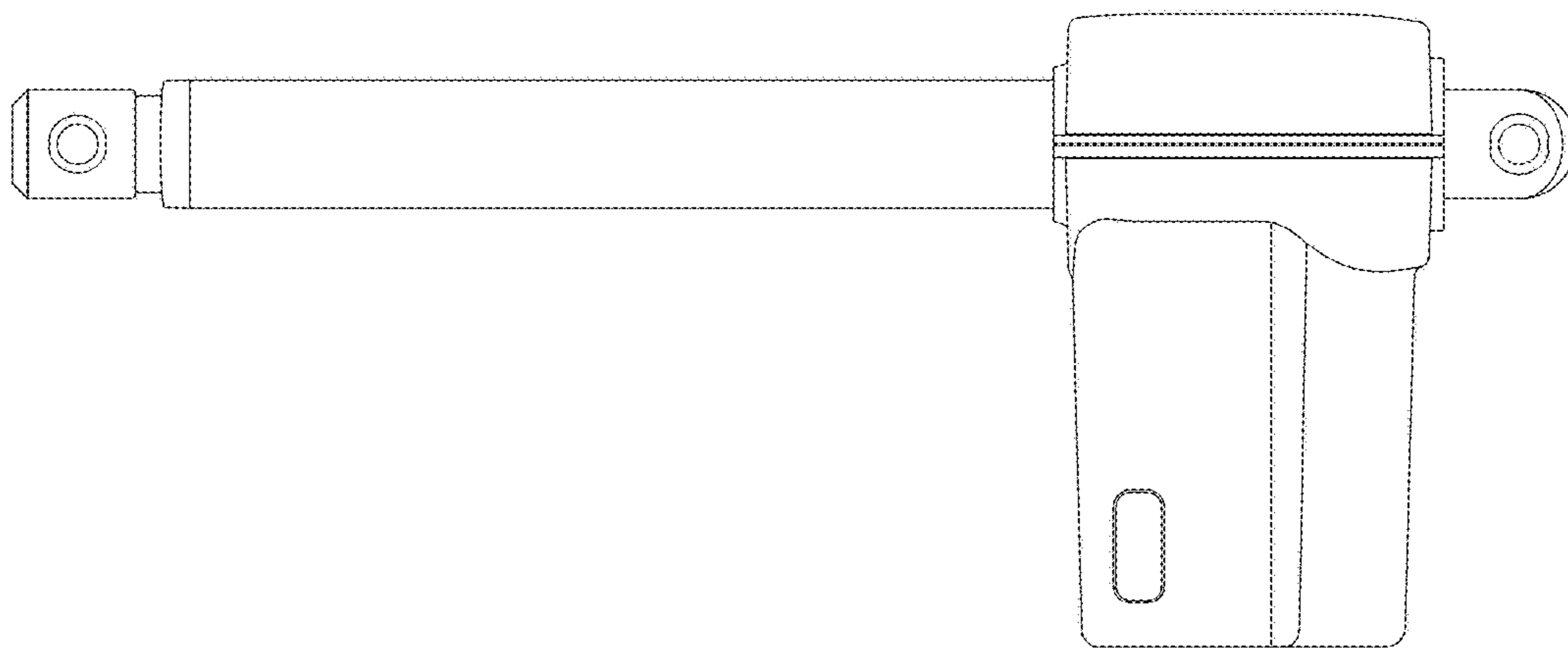

FIG. 3

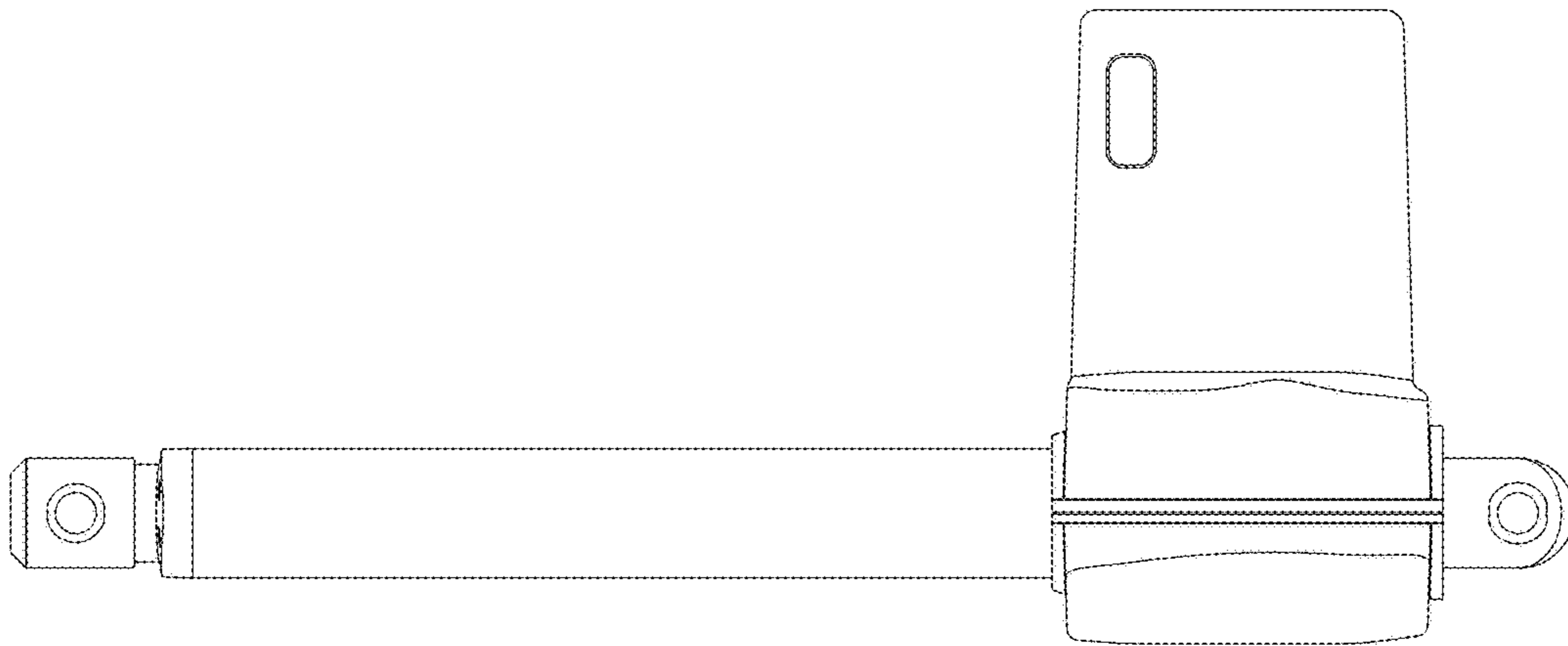

FIG. 4

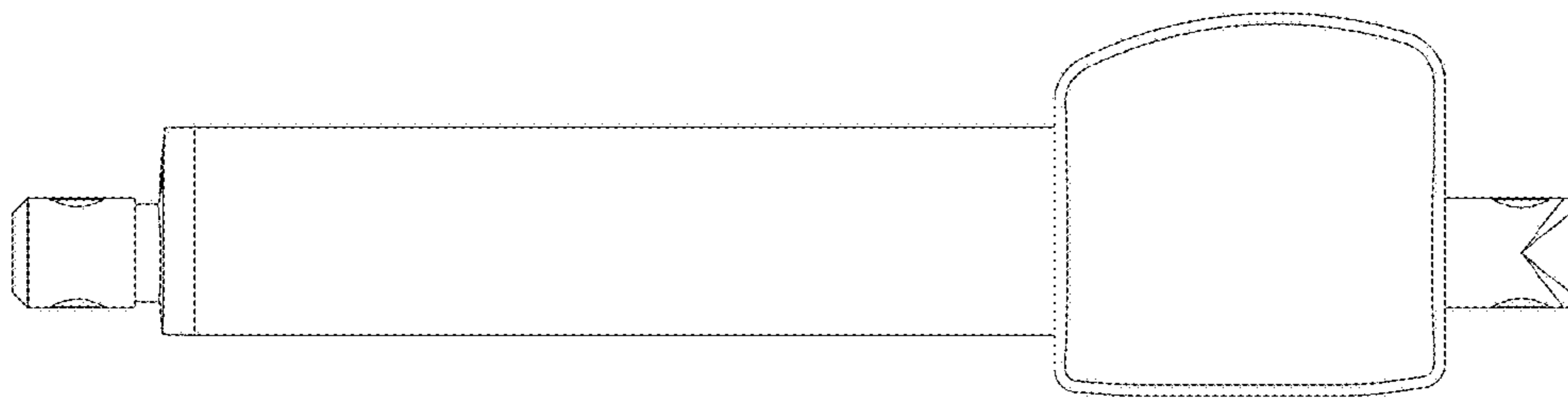

FIG. 5

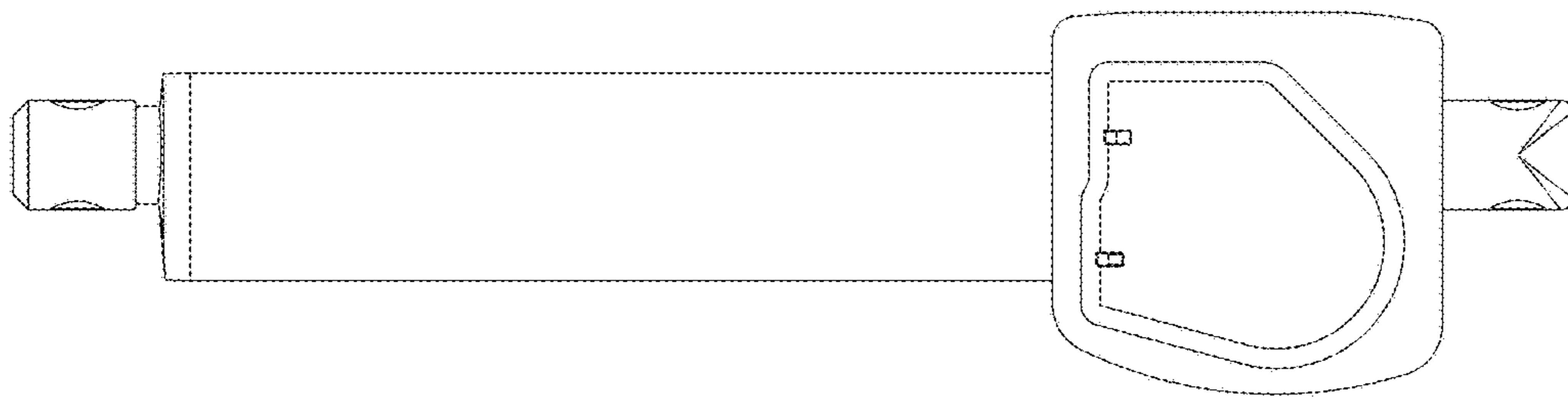

FIG. 6

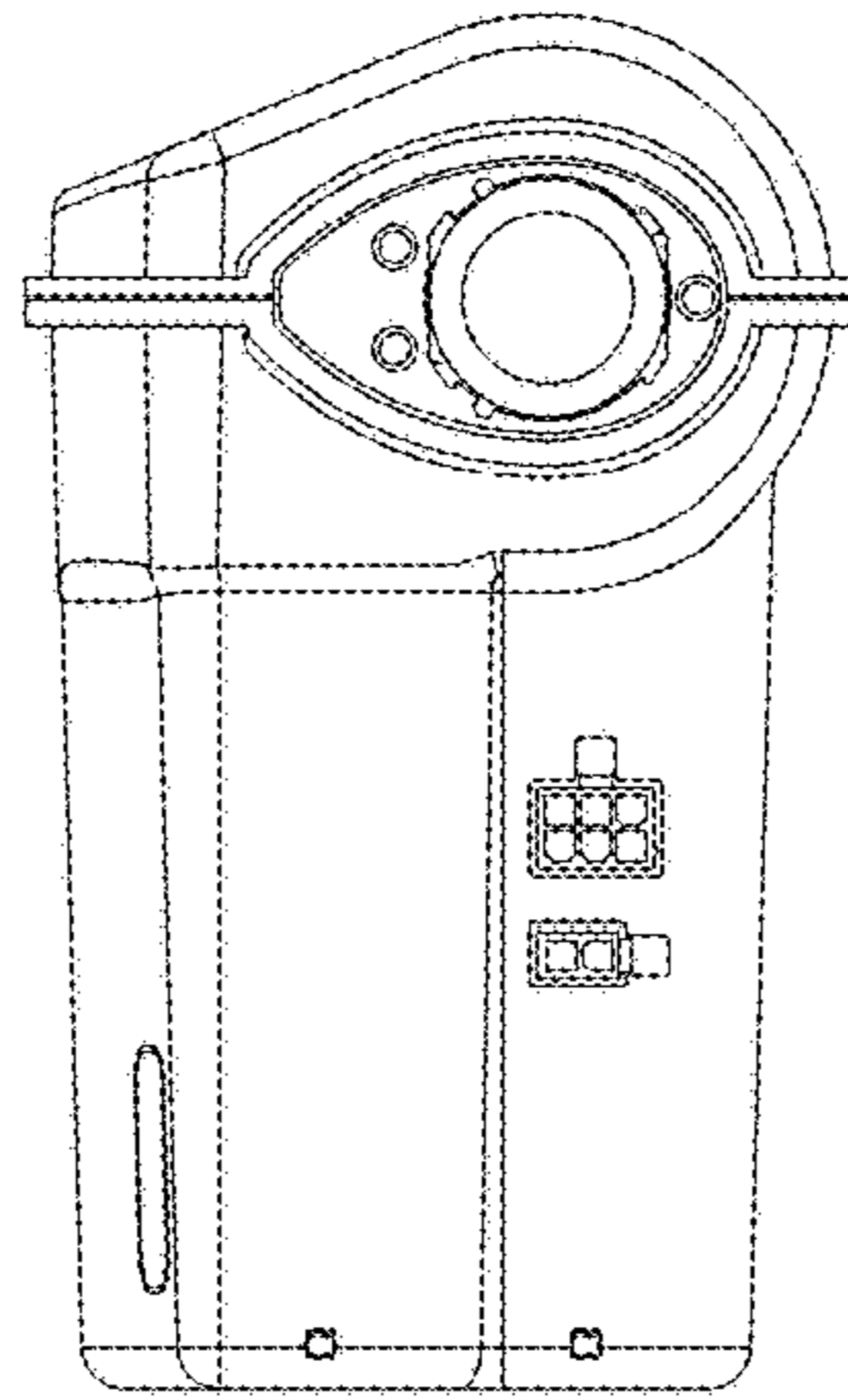

FIG. 7

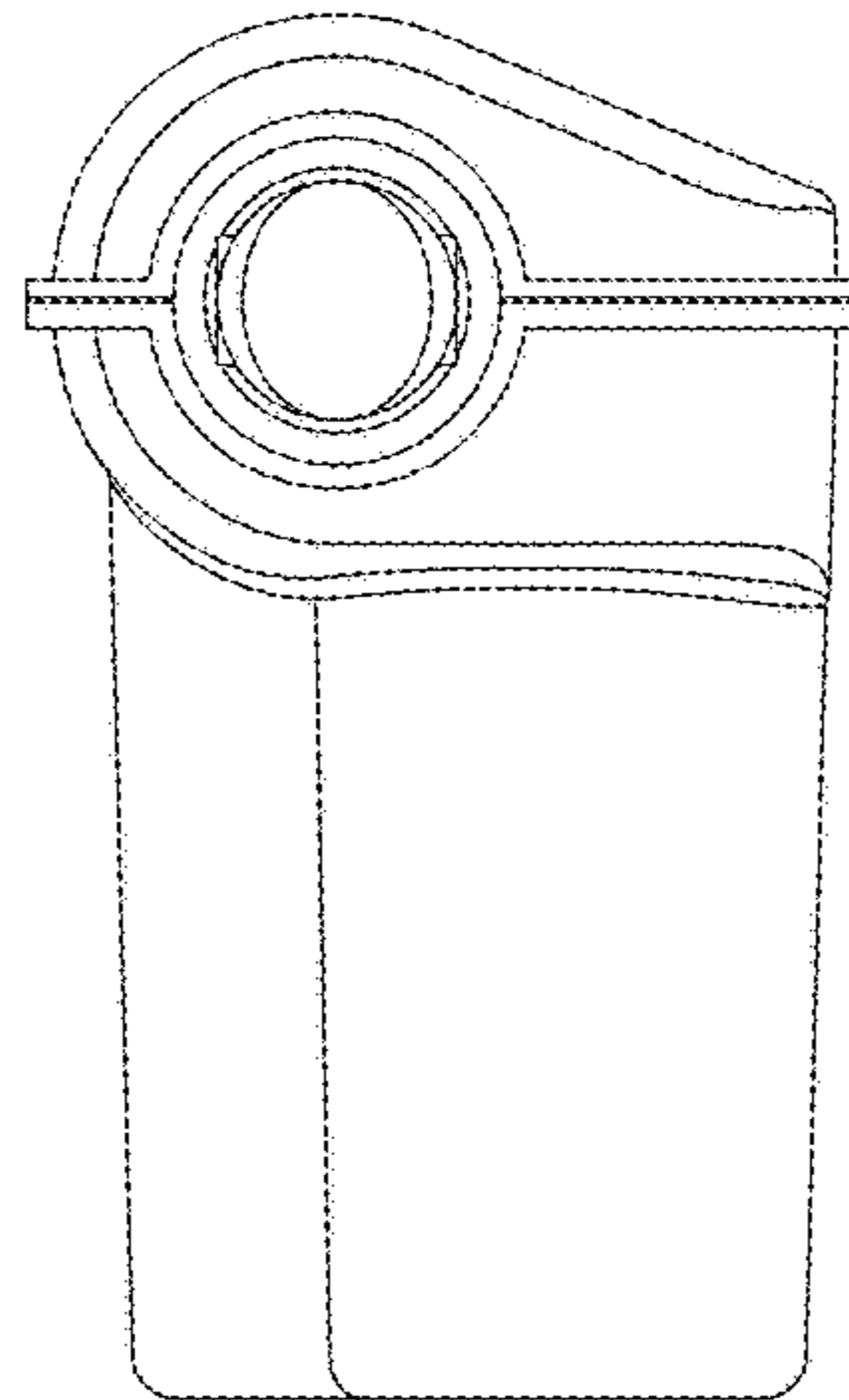

FIG. 8