



US00D805974S

(12) **United States Design Patent**
Buck

(10) **Patent No.:** **US D805,974 S**

(45) **Date of Patent:** **** Dec. 26, 2017**

(54) **FENDER FOR A VEHICLE**

D615,472 S * 5/2010 Maher D12/196
D782,380 S * 3/2017 Jensen D12/196
D784,886 S * 4/2017 Smith D12/196

(71) Applicant: **Jaguar Land Rover Limited**, Whitley,
Coventry (GB)

* cited by examiner

(72) Inventor: **Joe Buck**, Coventry (GB)

Primary Examiner — George D. Kirschbaum

Assistant Examiner — Joseph J Kukella

(73) Assignee: **Jaguar Land Rover Limited**, Whitley,
Coventry (GB)

(74) *Attorney, Agent, or Firm* — Wood Herron & Evans
LLP

(**) Term: **15 Years**

(57) **CLAIM**

The ornamental design for a fender for a vehicle, as shown
and described.

(21) Appl. No.: **29/567,791**

DESCRIPTION

(22) Filed: **Jun. 13, 2016**

(30) **Foreign Application Priority Data**

Jan. 14, 2016 (EM) 002944991

(51) **LOC (10) Cl.** **12-16**

(52) **U.S. Cl.**
USPC **D12/181**

(58) **Field of Classification Search**
USPC D12/82, 86, 90-93, 96-99, 175, 177,
D12/181, 184, 190, 196, 221
CPC B62D 35/00; B62D 35/001; B60J 1/00;
B60J 1/008

See application file for complete search history.

(56) **References Cited**

U.S. PATENT DOCUMENTS

D524,204 S * 7/2006 Beigel D12/184
D560,149 S * 1/2008 Leclercq D12/184

FIG. 1 is a front right perspective view of a fender for a
vehicle according to the present invention.

FIG. 2 is a rear left perspective view of the fender shown in
FIG. 1.

FIG. 3 is a front view thereof.

FIG. 4 is a rear view thereof.

FIG. 5 is a left side view thereof.

FIG. 6 is a right side view thereof.

FIG. 7 is a top view thereof; and,

FIG. 8 is a front view of the fender shown in FIG. 1, with
the fender mounted on a vehicle shown in de-emphasized
and half-tone portions so as to illustrate environmental
structures for the vehicle. These portions form no part of the
claimed invention. More particularly, in FIG. 8, the fender of
the present invention is shown within the broken lines, and
any elements shown outside of the broken lines form no part
of the claimed invention, but are instead included to show
environmental aspects of the claimed invention.

1 Claim, 8 Drawing Sheets

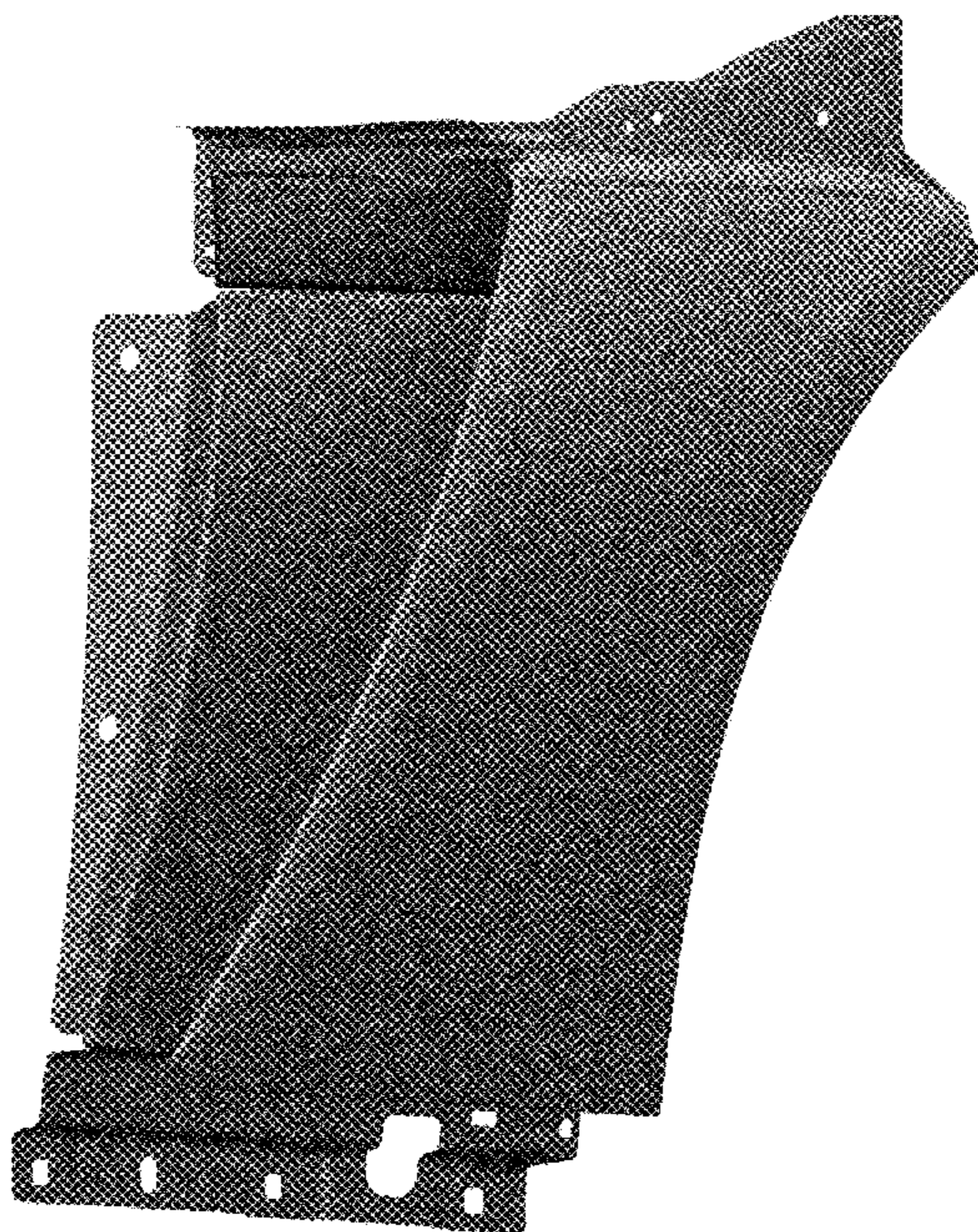

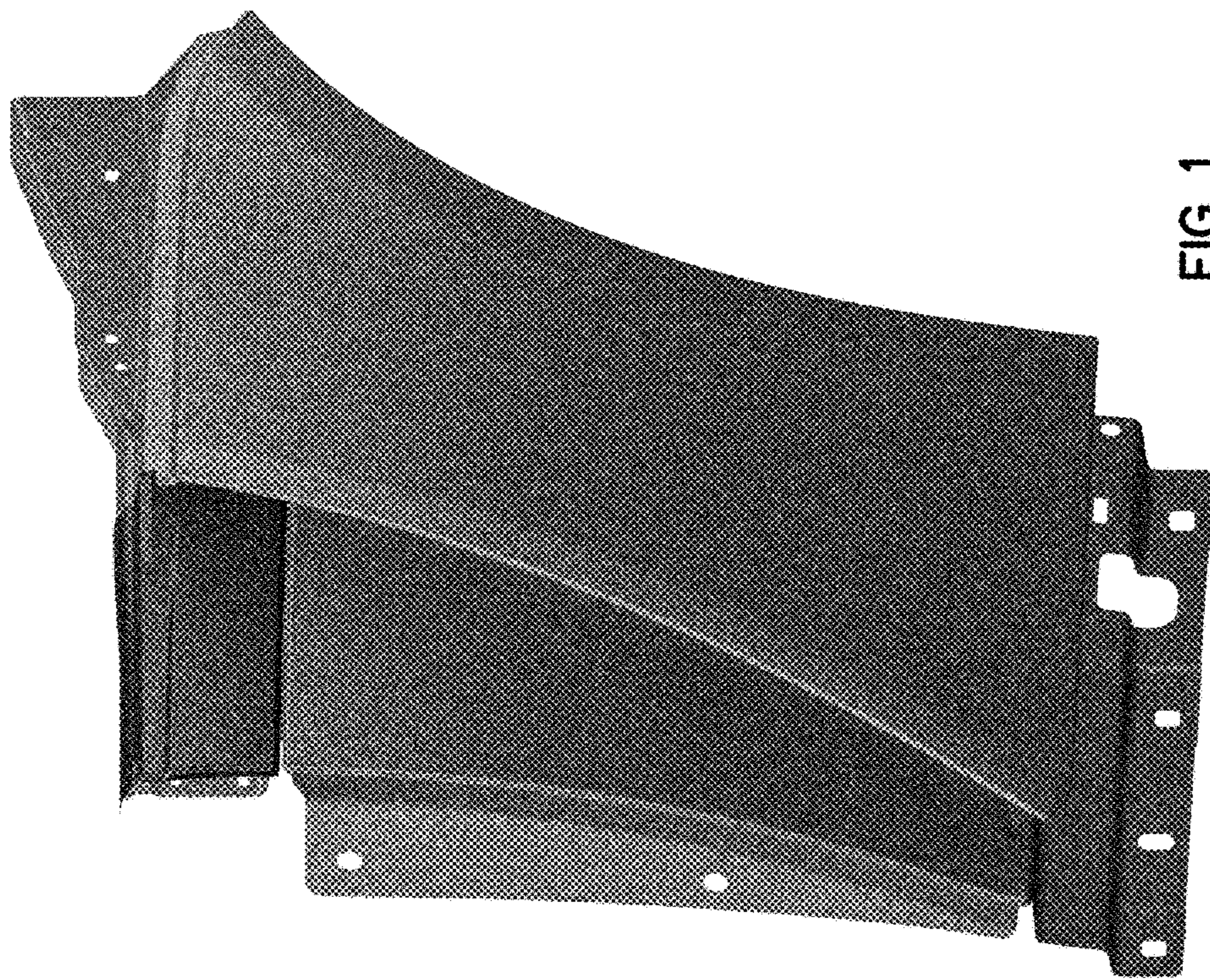

FIG. 1

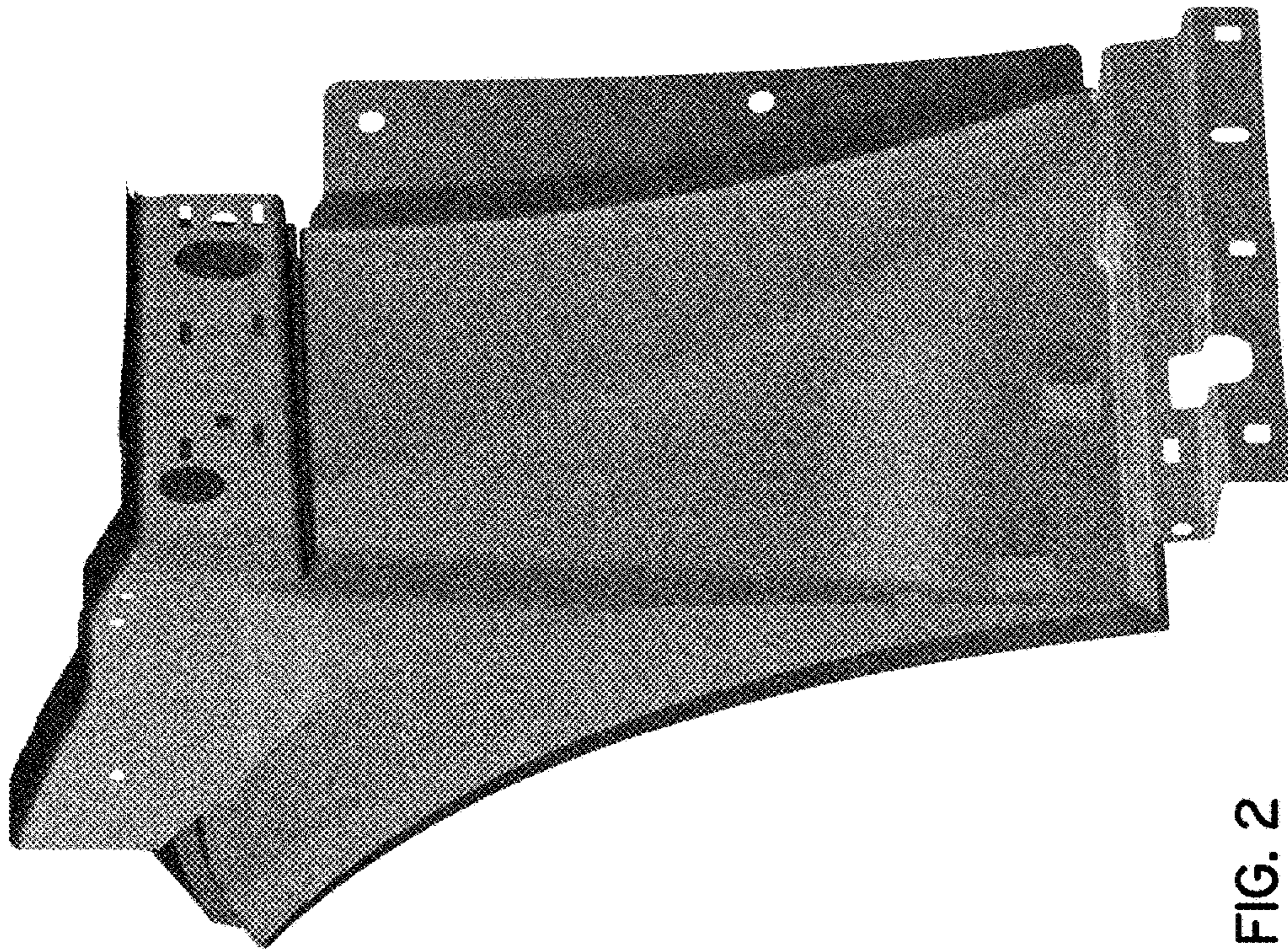

FIG. 2

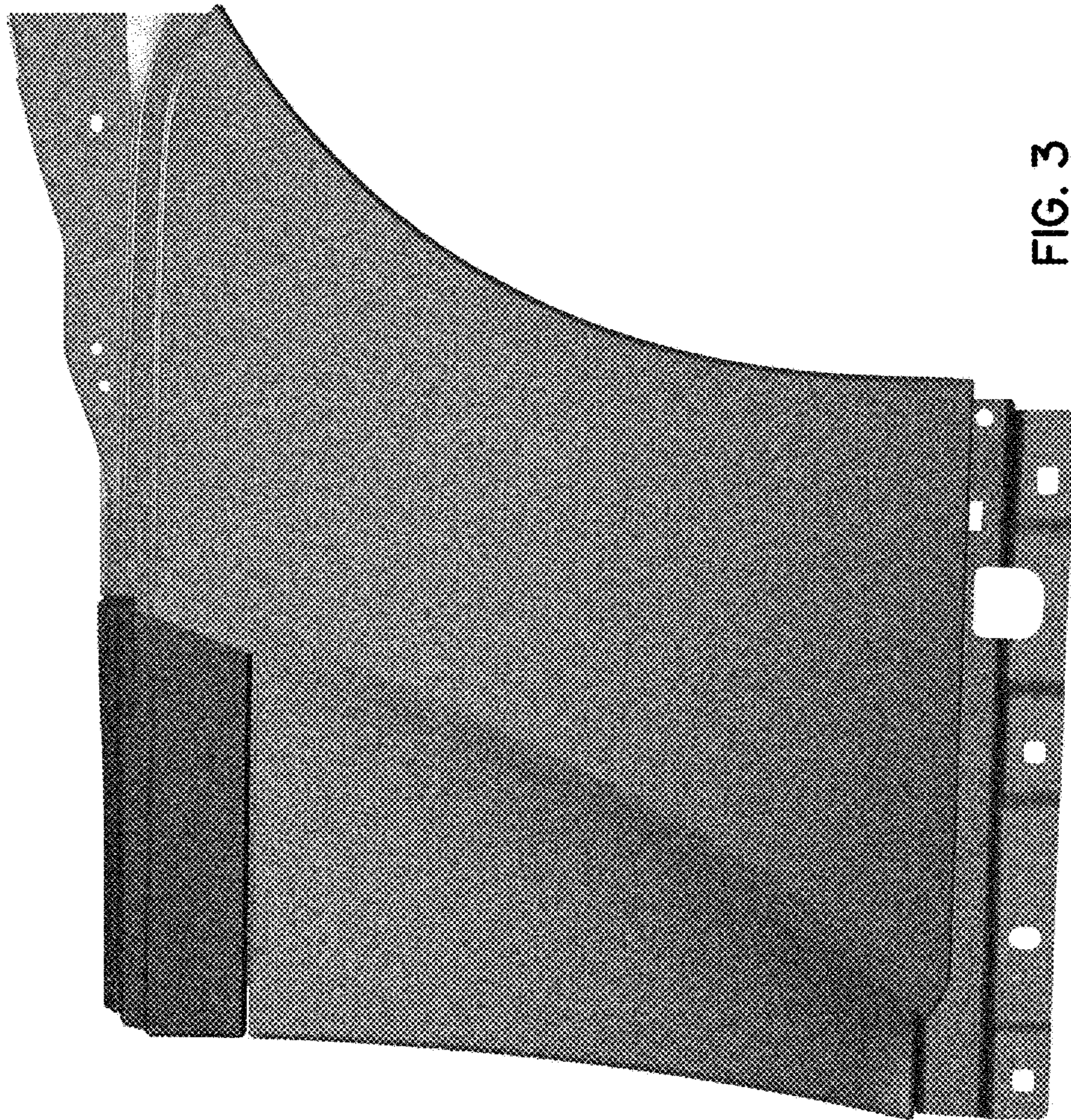

FIG. 3

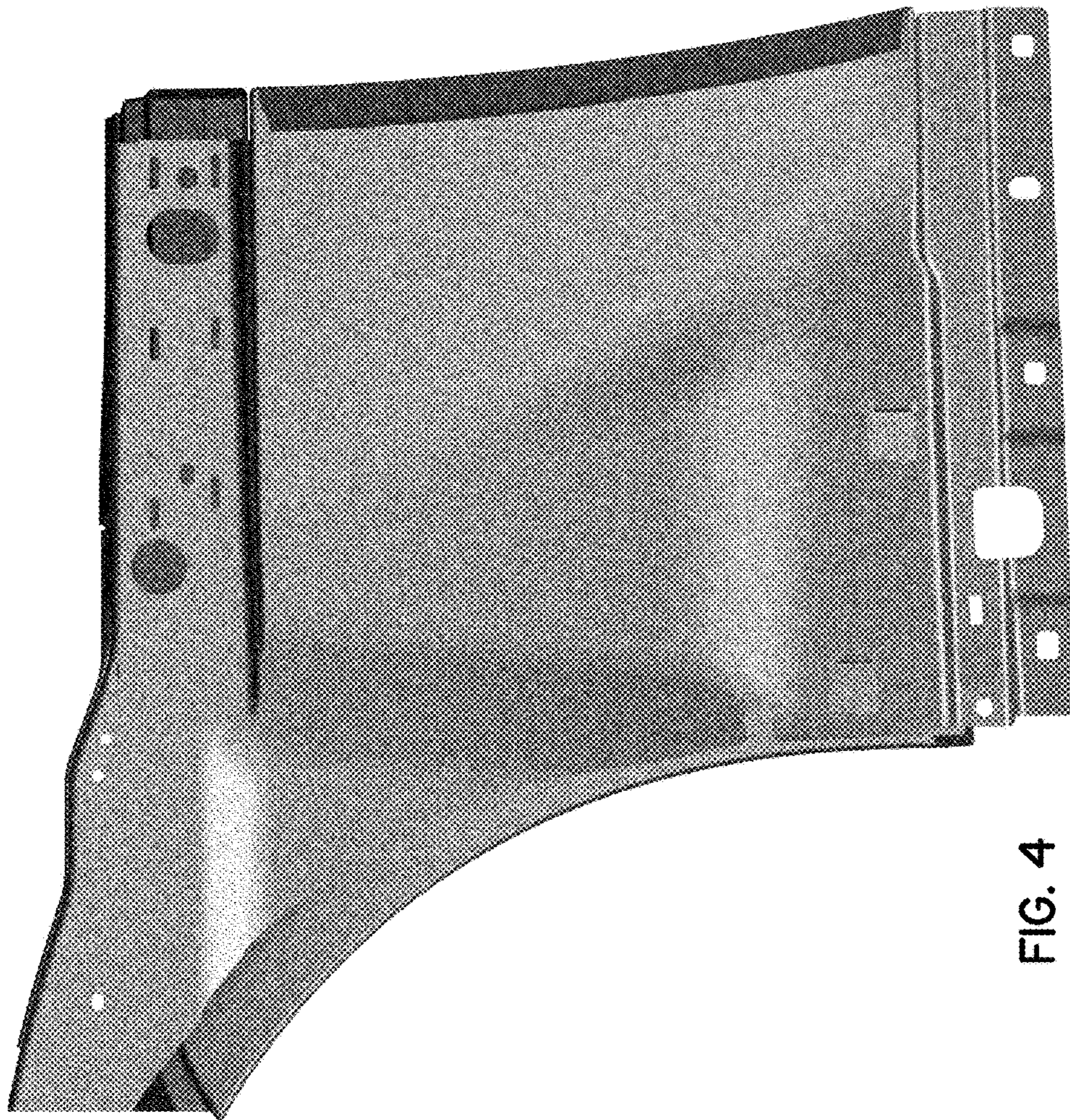

FIG. 4

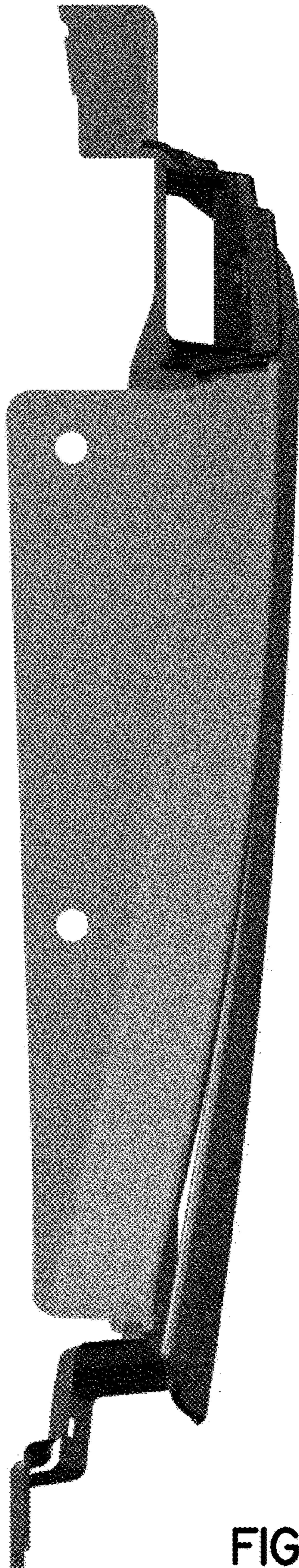

FIG. 5

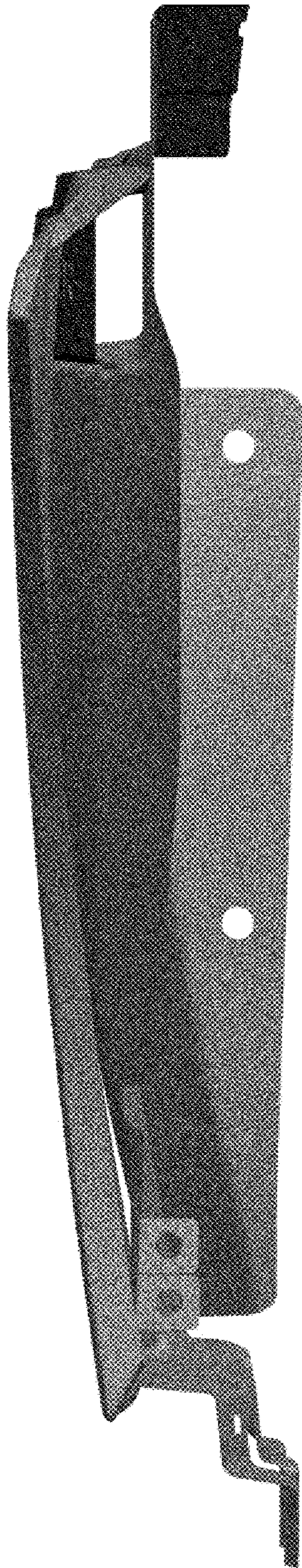

FIG. 6

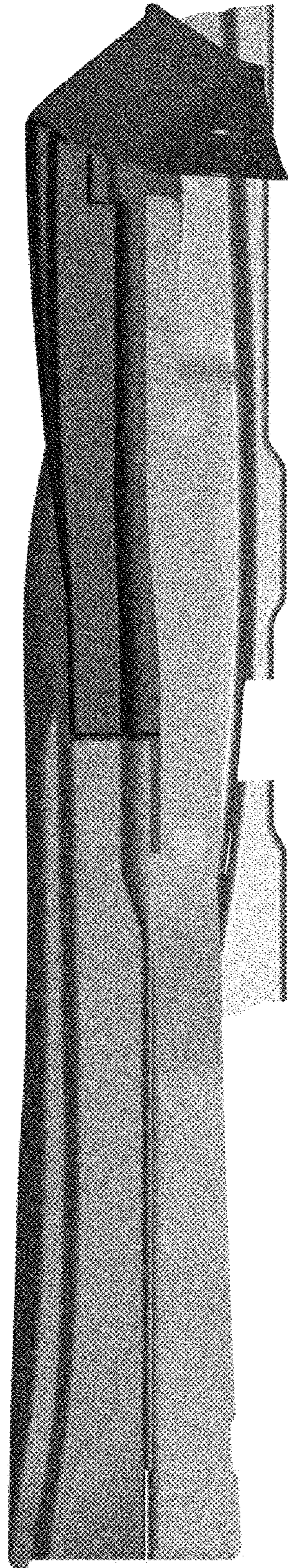

FIG. 7

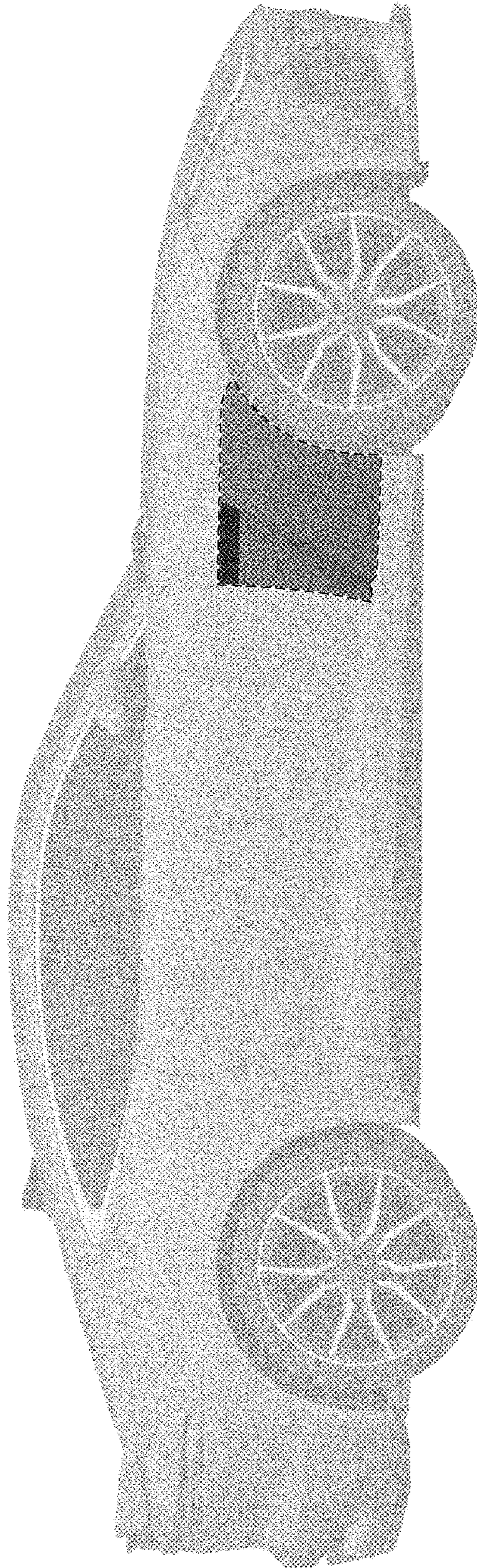

FIG. 8