

US00D805768S

(12) **United States Design Patent** (10) **Patent No.:** **US D805,768 S**  
**Nicotra et al.** (45) **Date of Patent:** **\*\* Dec. 26, 2017**

(54) **HANDBAG**  
(71) Applicant: **JUST NOW LIMITED**, Bromsgrove (GB)  
(72) Inventors: **Matteo Nicotra**, Milan (IT); **Stefania Braga**, Milan (IT); **Luca Veltri**, Milan (IT)  
(\*\*) Term: **15 Years**  
(21) Appl. No.: **35/501,068**  
(22) Filed: **May 27, 2016**

D340,351 S \* 10/1993 Wrath ..... D3/217  
D404,203 S \* 1/1999 Maier-Aichen ..... D3/245  
D414,082 S \* 9/1999 Keene ..... D3/246  
D497,250 S \* 10/2004 Anderson ..... D3/238  
D548,458 S \* 8/2007 Gregson, III ..... D3/245  
D598,647 S \* 8/2009 Kertesz ..... D3/232  
D632,480 S \* 2/2011 LaCorte ..... D3/232  
D659,996 S \* 5/2012 Fang ..... D3/232  
D706,030 S \* 6/2014 Wang ..... D3/245  
D753,389 S \* 4/2016 Marziari ..... D3/245  
D753,914 S \* 4/2016 Van Migem ..... D3/232  
D764,165 S \* 8/2016 Lagerfeld ..... D3/246  
D770,173 S \* 11/2016 Brophy ..... D3/232  
D771,940 S \* 11/2016 Wei ..... D3/232  
D781,051 S \* 3/2017 Leopardi ..... D3/232

\* cited by examiner

(80) **Hague Agreement Data**  
Int. Filing Date: **May 27, 2016**  
Int. Reg. No.: **DM/090874**  
Int. Reg. Date: **May 27, 2016**  
Int. Reg. Pub. Date: **Jun. 10, 2016**

*Primary Examiner* — Barbara Fox  
*Assistant Examiner* — Holly E Thurman

(30) **Foreign Application Priority Data**  
Dec. 1, 2015 (EP) ..... 002884924-009  
Dec. 1, 2015 (EP) ..... 002884924-0012

(57) **CLAIM**

The ornamental design for a handbag, as shown and described.

(51) **LOC (10) Cl.** ..... **03-01**  
(52) **U.S. Cl.**  
USPC ..... **D3/232**  
(58) **Field of Classification Search**  
USPC ..... D3/201, 318, 321, 240–243, 245–247, D3/249–253; 150/100, 103–110, 150/113–114, 117–119, 130, 132, 150/136–137, 147  
CPC ..... A45C 1/024; A45C 3/06  
See application file for complete search history.

**DESCRIPTION**

- 2. Handbag
- 2.1 : Perspective
- 2.2 : Front
- 2.3 : Left
- 2.4 : Back
- 2.5 : Right
- 2.6 : Top
- 2.7 : Bottom

(56) **References Cited**  
U.S. PATENT DOCUMENTS  
D55,451 S \* 6/1920 Carraine ..... D3/246  
D122,628 S \* 9/1940 Lewis ..... D3/240  
D207,194 S \* 3/1967 Artmann ..... D3/232  
D260,325 S \* 8/1981 Davis ..... D3/234

**1 Claim, 7 Drawing Sheets**

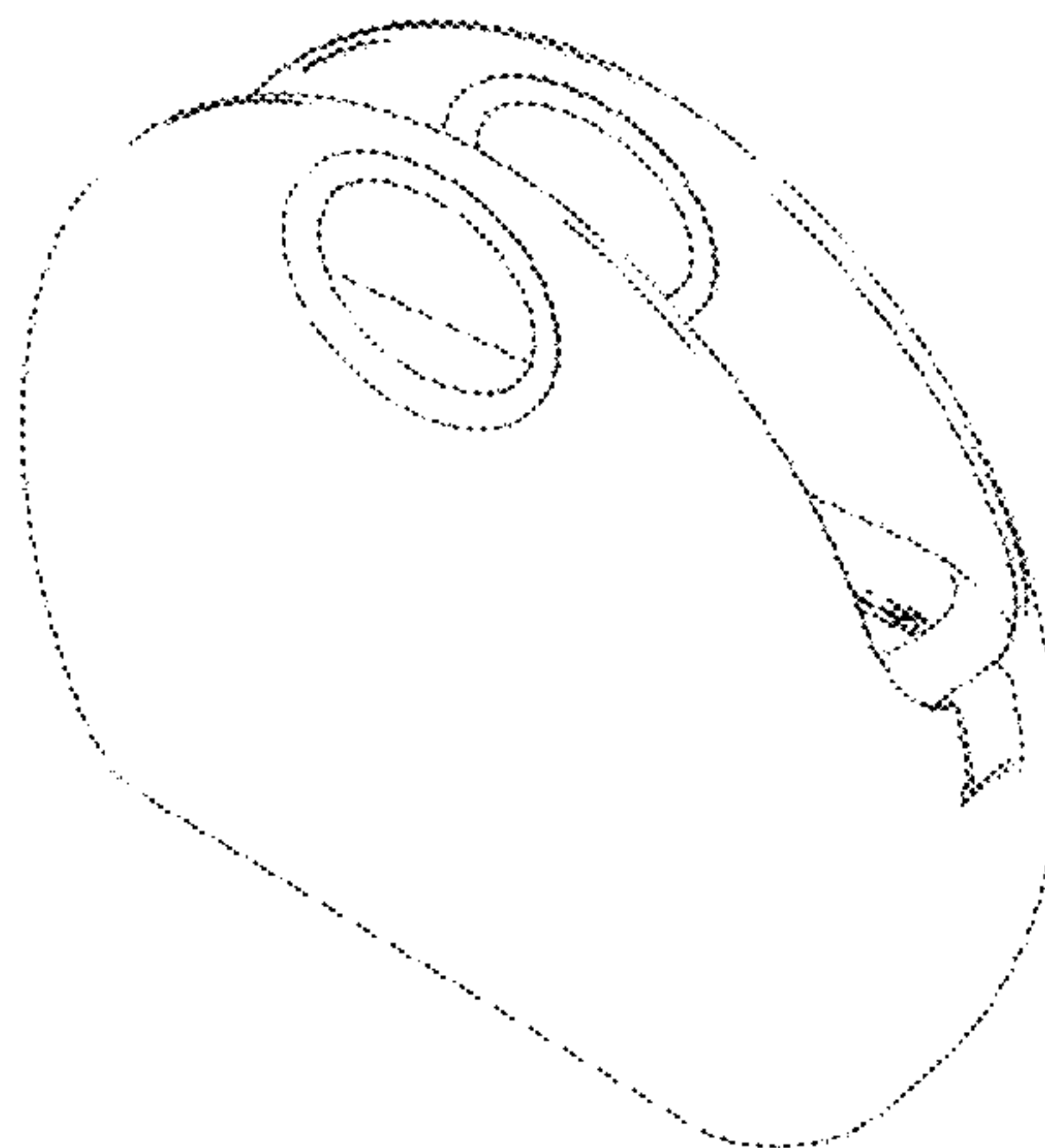

**2.1**

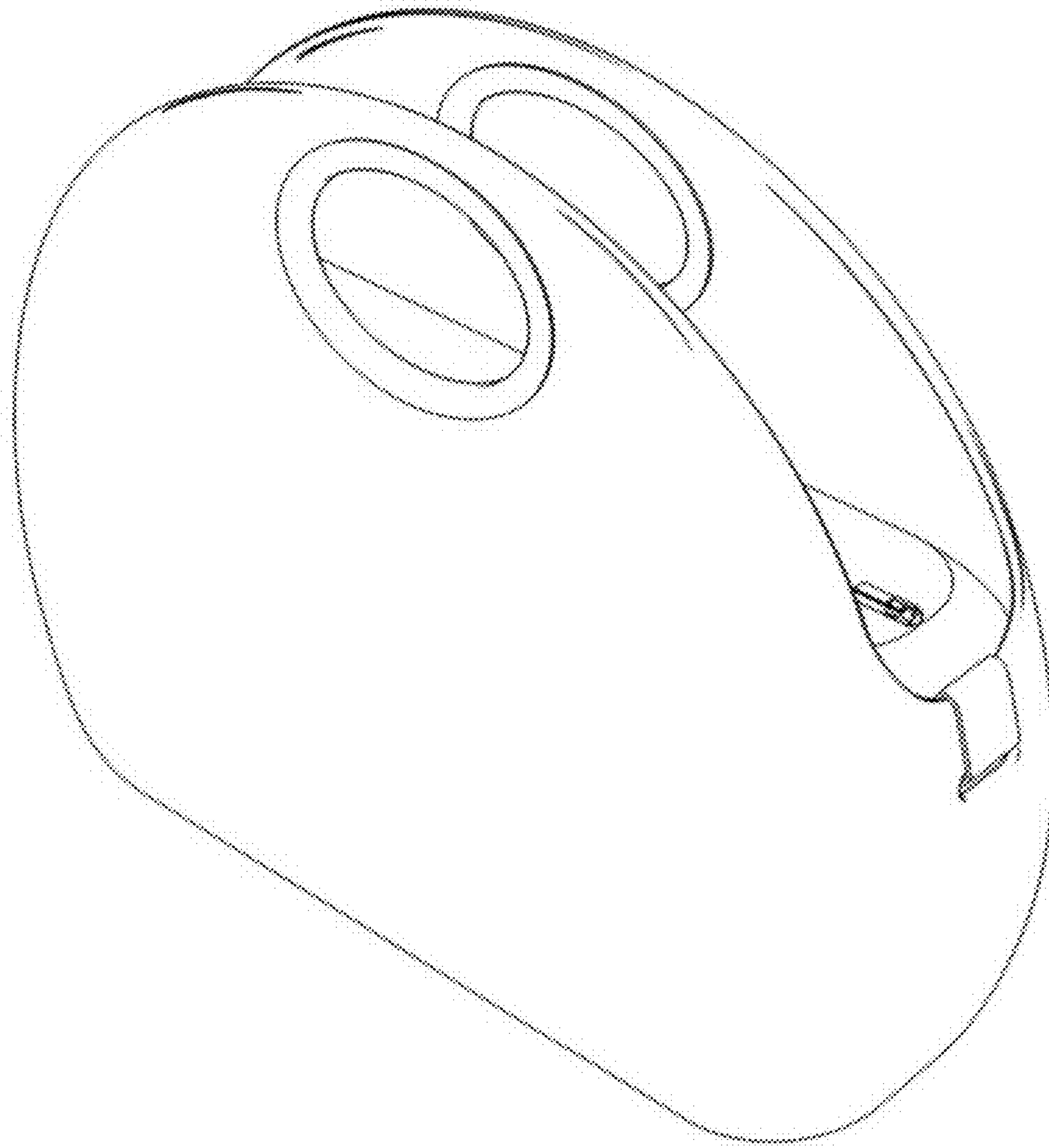

2.2

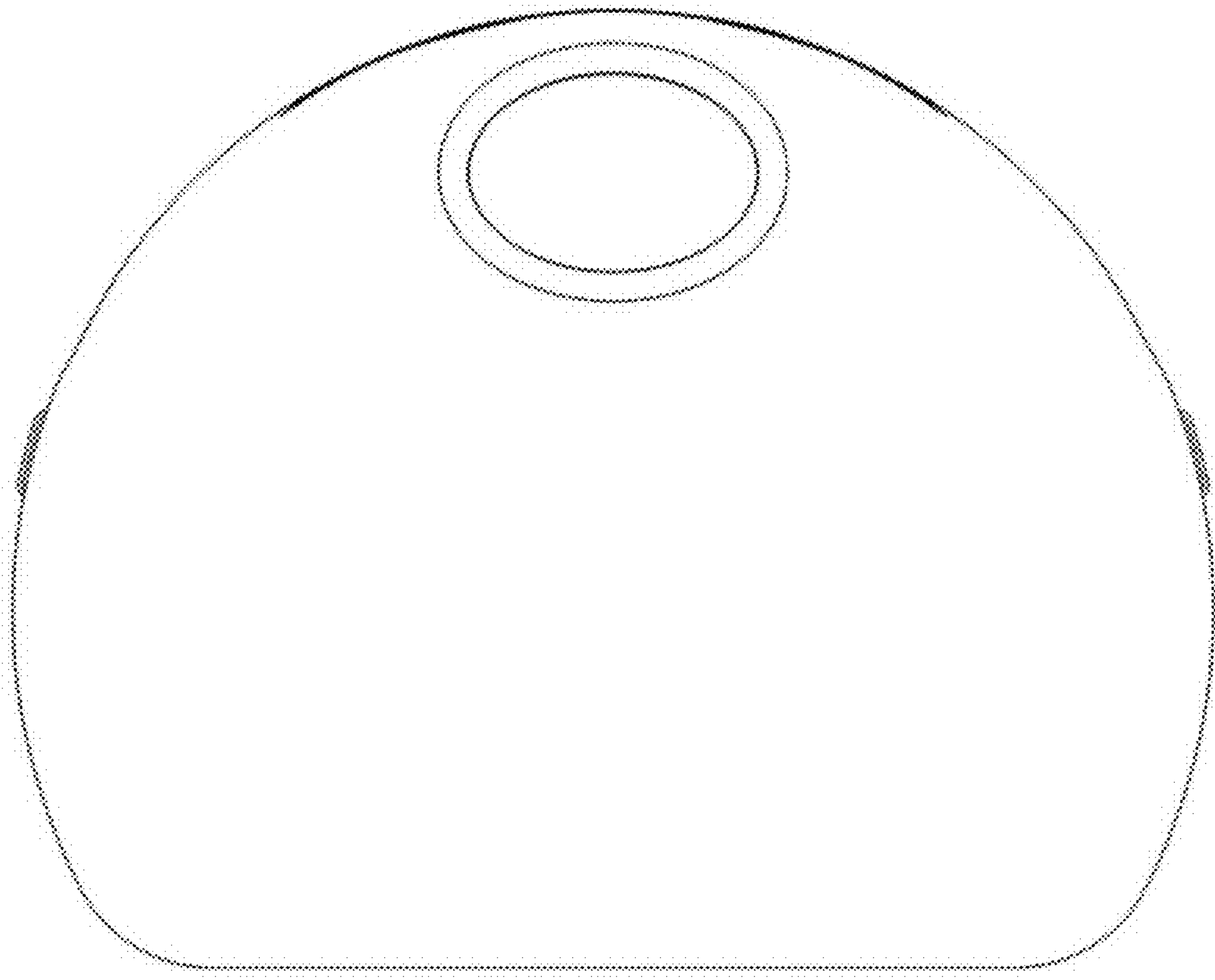

2.3

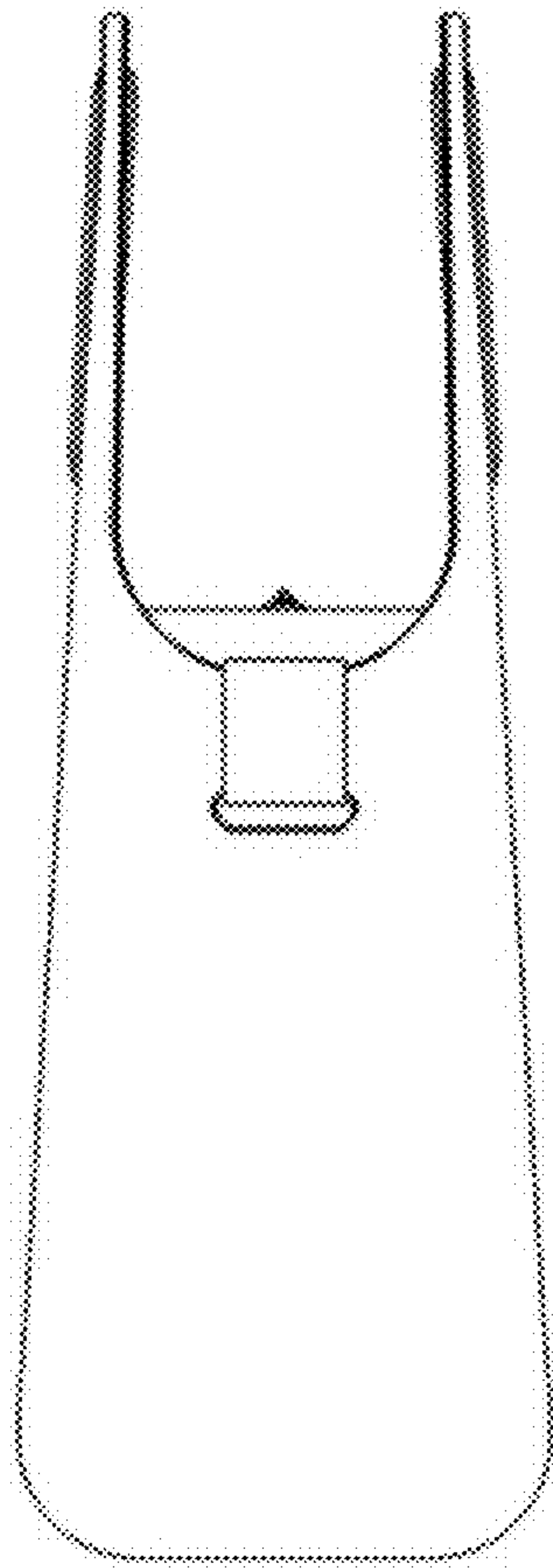

2.4

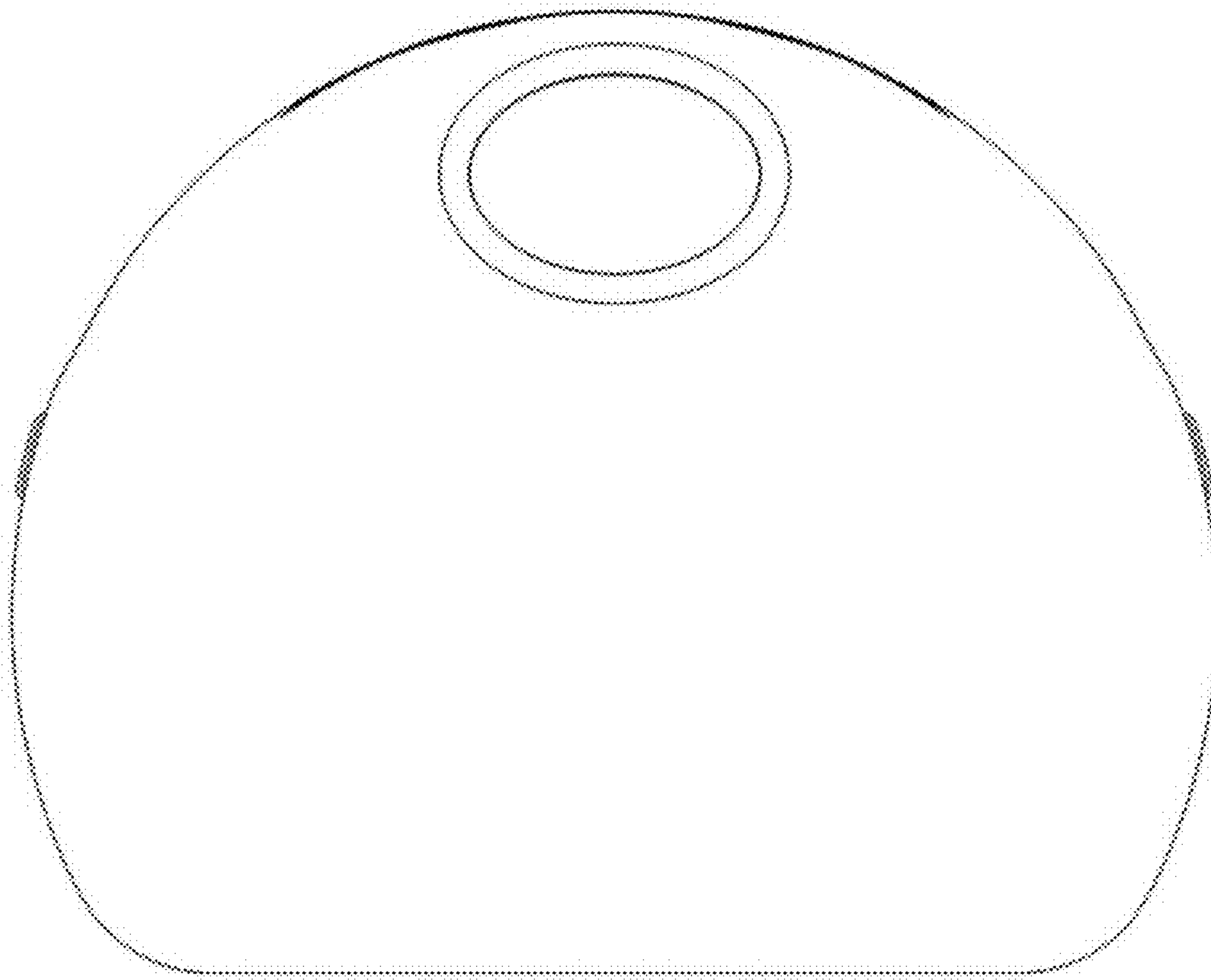

2.5

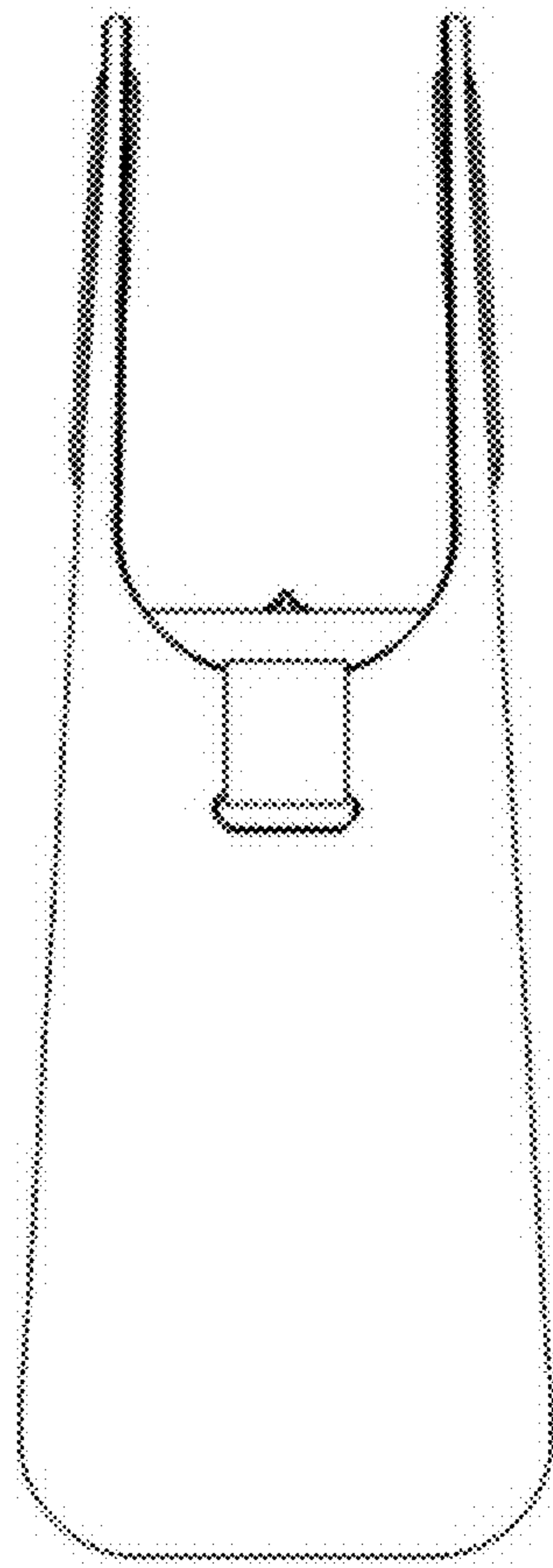

2.6

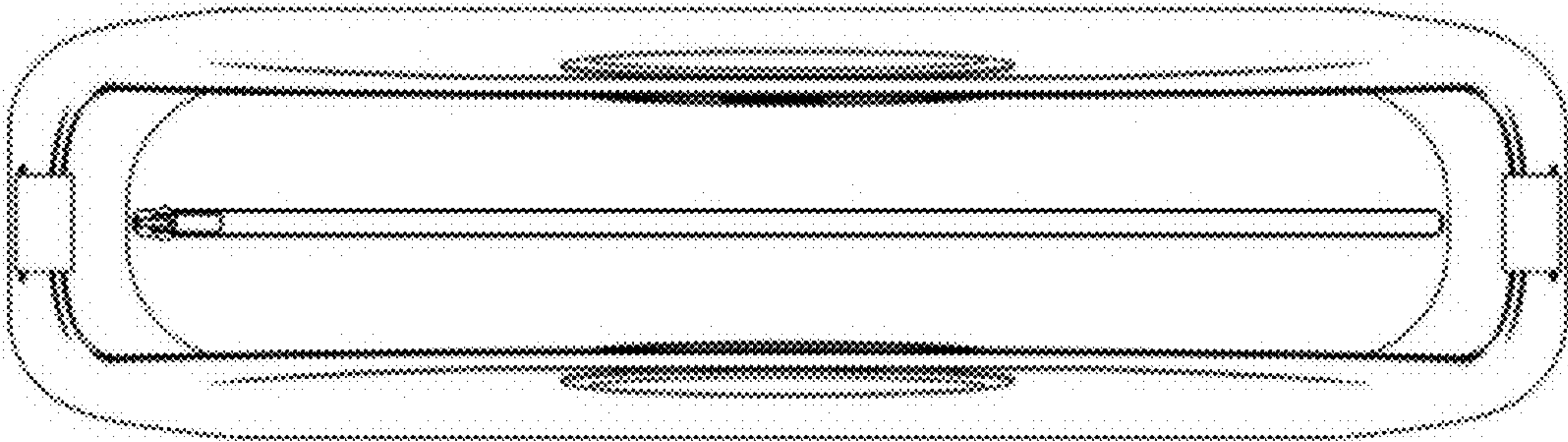

2.7

