



US00D805560S

(12) **United States Design Patent**  
**Kudo et al.**

(10) **Patent No.:** **US D805,560 S**  
(45) **Date of Patent:** **\*\* Dec. 19, 2017**

(54) **FLUID PRESSURE CYLINDER**

(71) Applicant: **SMC CORPORATION**, Tokyo (JP)

(72) Inventors: **Masayuki Kudo**, Tsukubamirai (JP);  
**Shinichiro Nemoto**, Tsukubamirai (JP);  
**Yuu Mizutani**, Tsukubamirai (JP); **Eiko Miyasato**, Tsukubamirai (JP);  
**Masahiko Kawakami**, Tsukubamirai (JP); **Ken Tamura**, Tsukubamirai (JP)

(73) Assignee: **SMC CORPORATION**, Tokyo (JP)

(\*\*) Term: **15 Years**

(21) Appl. No.: **29/577,928**

(22) Filed: **Sep. 16, 2016**

(30) **Foreign Application Priority Data**

Mar. 18, 2016 (CN) ..... 2016 3 0078458

(51) **LOC (10) Cl.** ..... **15-02**

(52) **U.S. Cl.**  
USPC ..... **D15/7**

(58) **Field of Classification Search**

USPC ..... D15/7-9, 143; D23/231, 232, 225;  
417/60, 235, 265, 321, 355, 358, 363,  
417/359, 410.1, 415-416, 405, 900;  
60/408, 412; 184/26-37; 415/140-147;  
123/495, 509

(Continued)

(56) **References Cited**

**U.S. PATENT DOCUMENTS**

4,856,415 A \* 8/1989 Noda ..... F15B 15/082  
384/42  
D370,683 S \* 6/1996 Stahlman ..... D15/7  
(Continued)

**FOREIGN PATENT DOCUMENTS**

CN 303428901 S 11/2015  
JP D1528332 S 7/2015

*Primary Examiner* — Ralf T Seifert

(74) *Attorney, Agent, or Firm* — Birch, Stewart, Kolasch & Birch, LLP

(57) **CLAIM**

The ornamental design for a fluid pressure cylinder, as shown.

**DESCRIPTION**

FIG. 1 is a front, top and left side perspective view of a fluid pressure cylinder showing a first embodiment of our design; FIG. 2 is a rear, bottom and right side perspective view thereof;

FIG. 3 is a front view thereof;

FIG. 4 is a rear view thereof;

FIG. 5 is a top plan view thereof;

FIG. 6 is a bottom plan view thereof;

FIG. 7 is a left side view thereof;

FIG. 8 is a right side view thereof;

FIG. 9 is a front, top left side perspective view of a fluid pressure cylinder showing a second embodiment of our new design;

FIG. 11 is a rear, bottom and right side perspective view of FIG. 9;

FIG. 12 is front view of FIG. 9;

FIG. 13 is a rear view of FIG. 9;

FIG. 14 is a top plan view of FIG. 9;

FIG. 15 is a bottom plan view of FIG. 9;

FIG. 16 is a left side view of FIG. 9;

FIG. 17 is a front, top and left side perspective view of a fluid pressure cylinder showing a third embodiment of our new design;

FIG. 18 is a rear, bottom and right side perspective view of FIG. 17;

FIG. 19 is a front view of FIG. 17;

FIG. 20 is a rear view of FIG. 17;

FIG. 21 is a top plan view of FIG. 17;

FIG. 22 is a bottom plan view of FIG. 17;

FIG. 23 is a left side view of FIG. 17;

FIG. 24 is a right side view of FIG. 17;

FIG. 25 is a front, top and left side perspective view of a fluid pressure cylinder showing a fourth embodiment of our new design;

(Continued)

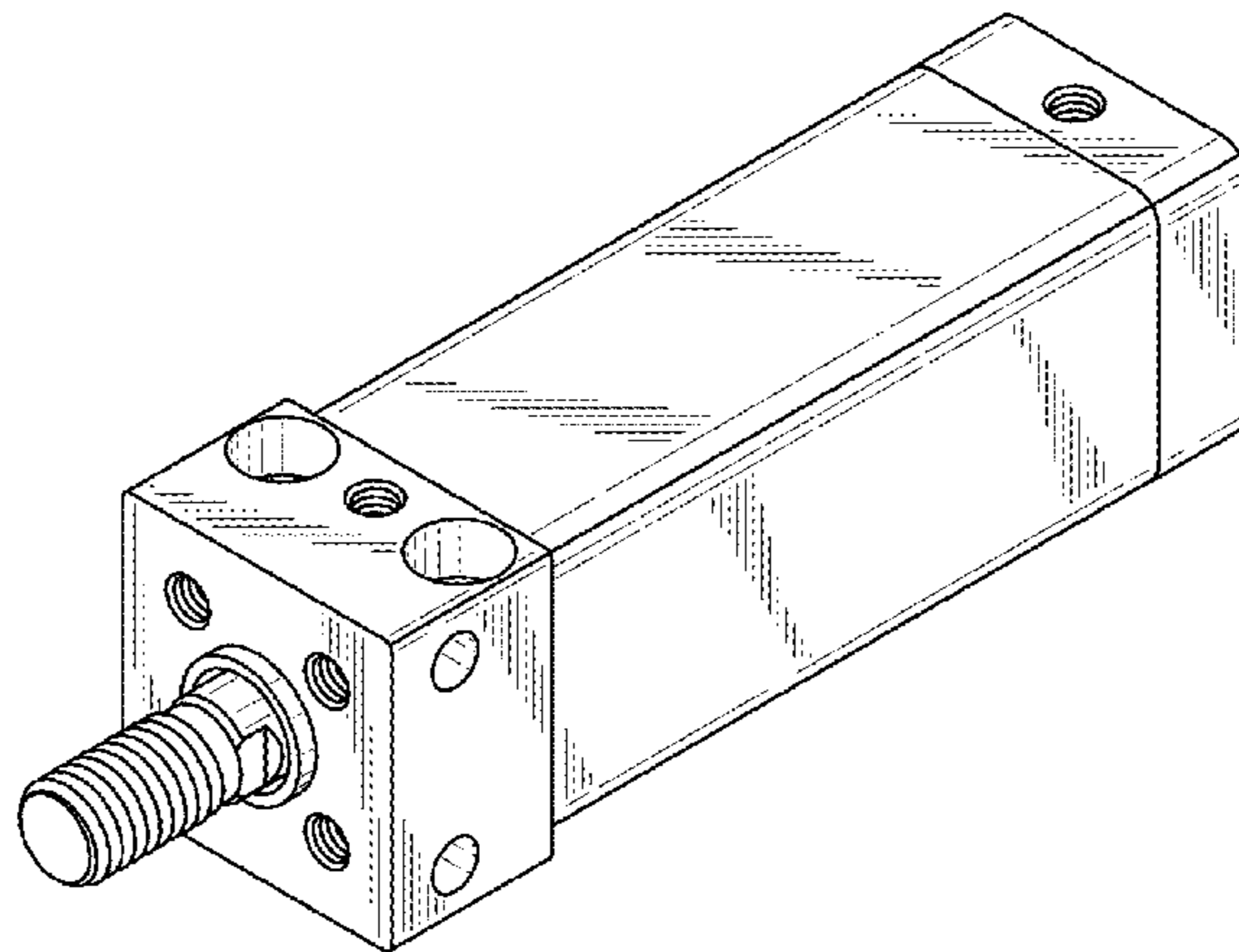

FIG. 26 is a rear, bottom and right side perspective view of FIG. 25;  
 FIG. 27 is a front view of FIG. 25;  
 FIG. 28 is a rear view of FIG. 25;  
 FIG. 29 is a top plan view of FIG. 25;  
 FIG. 30 is a bottom plan view of FIG. 25;  
 FIG. 31 is a left side view of FIG. 25;  
 FIG. 32 is a right side view of FIG. 25;  
 FIG. 33 is a front, top and left side perspective view of a fluid pressure cylinder showing a fifth embodiment of our new design;  
 FIG. 34 is a rear, bottom and right side perspective view of FIG. 33;  
 FIG. 35 is a front view of FIG. 33;  
 FIG. 36 is a rear view of FIG. 33;  
 FIG. 37 is a top plan view of FIG. 33;  
 FIG. 38 is a bottom plan view of FIG. 33;  
 FIG. 39 is a left side view of FIG. 33;  
 FIG. 40 is a right side view of FIG. 33;  
 FIG. 41 is a front, top and left side perspective view of a fluid pressure cylinder showing a sixth embodiment of our new design;  
 FIG. 42 is a rear, bottom and right side perspective view of FIG. 41;  
 FIG. 43 is a front view of FIG. 41;  
 FIG. 44 is a rear view of FIG. 41;  
 FIG. 45 is a top plan view of FIG. 41;  
 FIG. 46 is a bottom plan view of FIG. 41;

FIG. 47 is a left side view of FIG. 41; and,  
 FIG. 48 is a right side view of FIG. 41.

**1 Claim, 48 Drawing Sheets**

(58) **Field of Classification Search**  
 CPC ..... F02M 37/04; F02M 31/14; F04D 29/4286  
 See application file for complete search history.

(56) **References Cited**

U.S. PATENT DOCUMENTS

D378,214	S	*	2/1997	Ikumi	.....	D15/143
D378,680	S	*	4/1997	Ikumi	.....	D15/7
D417,457	S	*	12/1999	Asahara	.....	D15/7
D428,617	S	*	7/2000	Hariwara	.....	D15/7
D643,856	S	*	8/2011	Taniguchi	.....	D15/7
D669,097	S	*	10/2012	Hariwara	.....	D15/7
D669,098	S	*	10/2012	Hariwara	.....	D15/7
D699,759	S	*	2/2014	Peschel	.....	D15/7
D699,760	S	*	2/2014	Peschel	.....	D15/7
D699,761	S	*	2/2014	Peschel	.....	D15/7
D757,120	S	*	5/2016	Kudo	.....	D15/7
D760,805	S	*	7/2016	Monden	.....	D15/7
D772,302	S	*	11/2016	Kudo	.....	D15/7
D780,228	S	*	2/2017	Kudo	.....	D15/7
D780,229	S	*	2/2017	Kudo	.....	D15/7

\* cited by examiner

FIG. 1

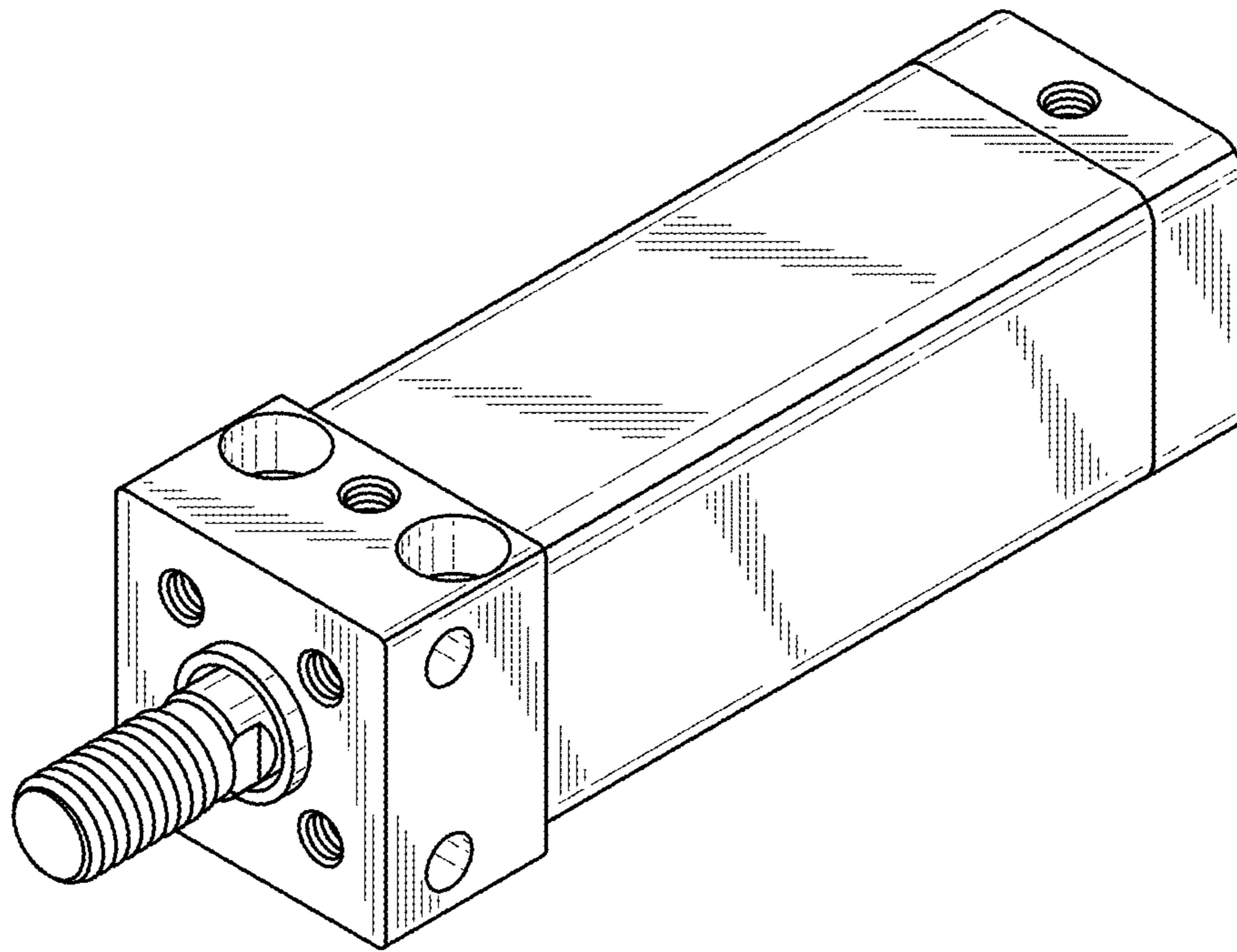

FIG. 2

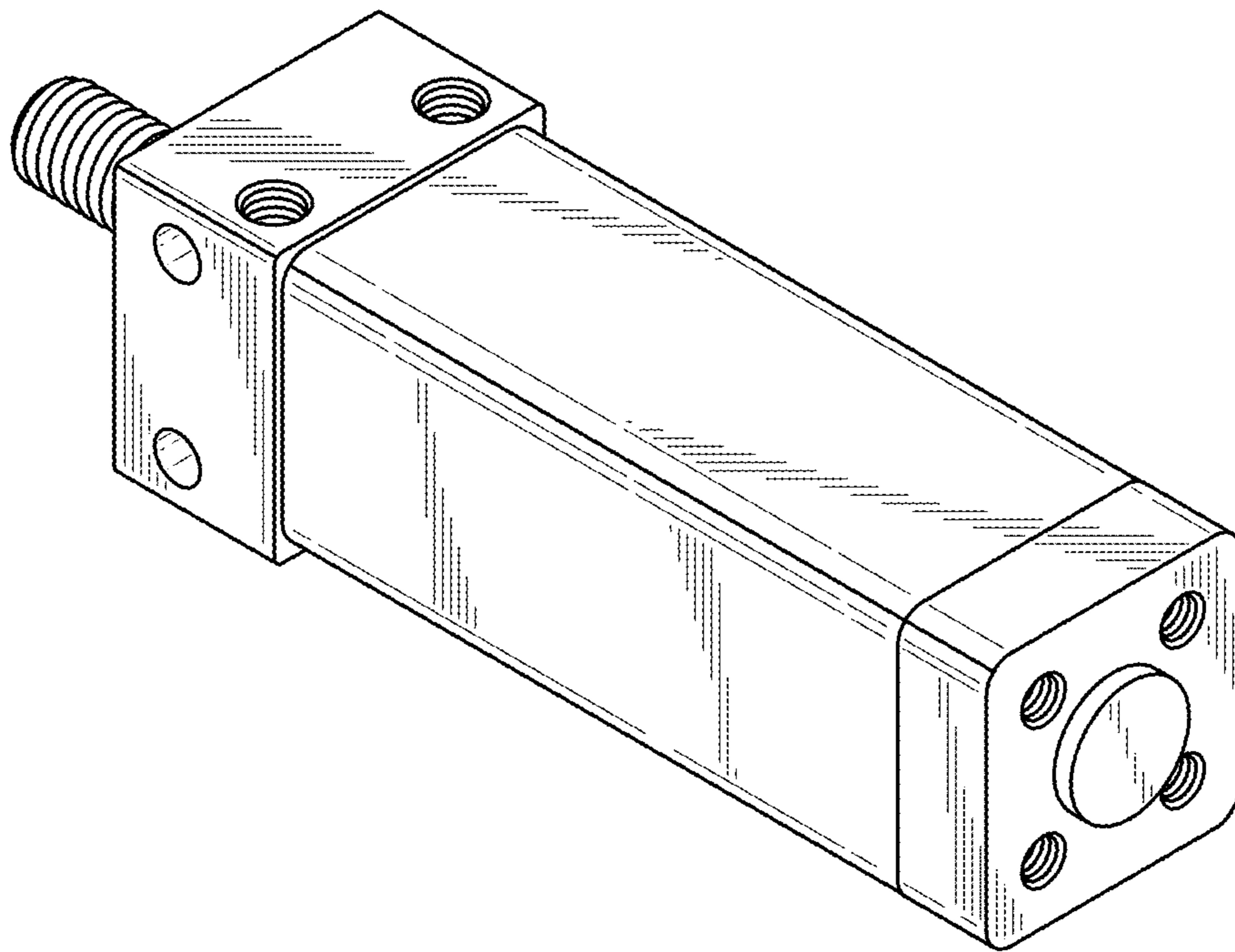

FIG. 3

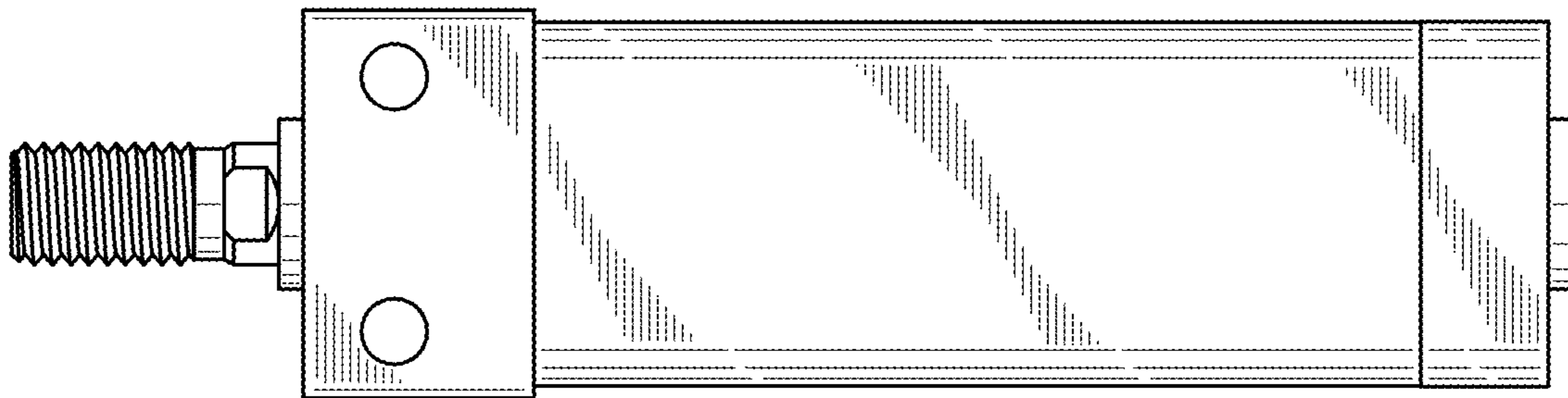



FIG. 4

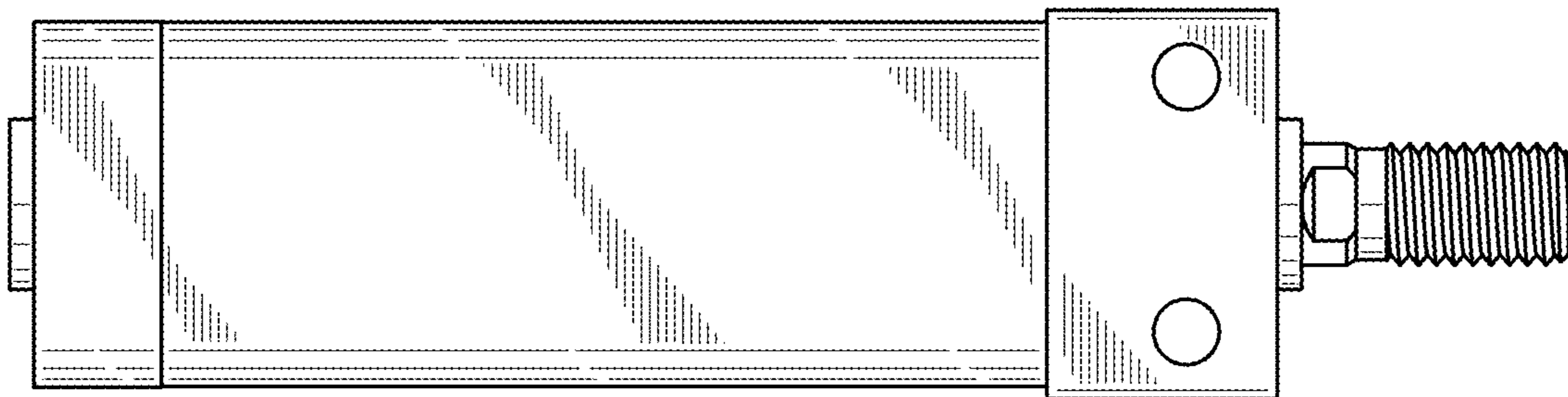

FIG. 5

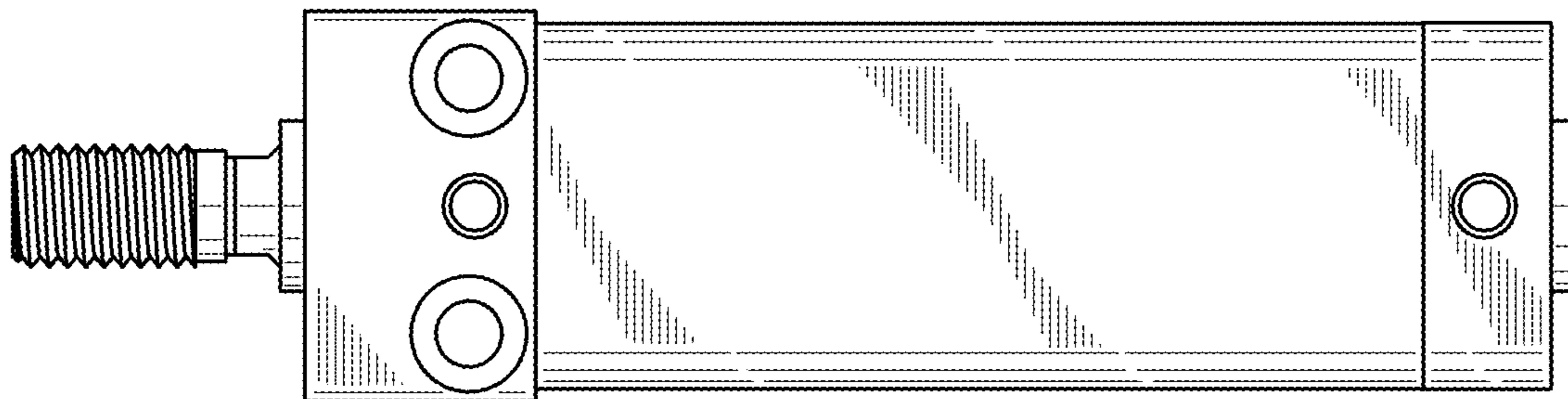

FIG. 6

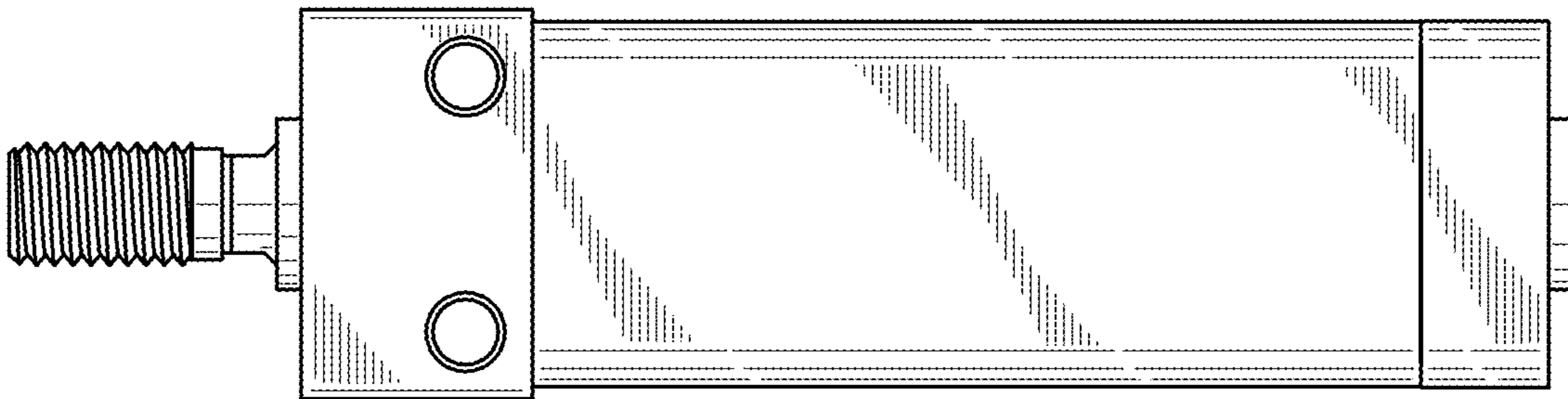



FIG. 7

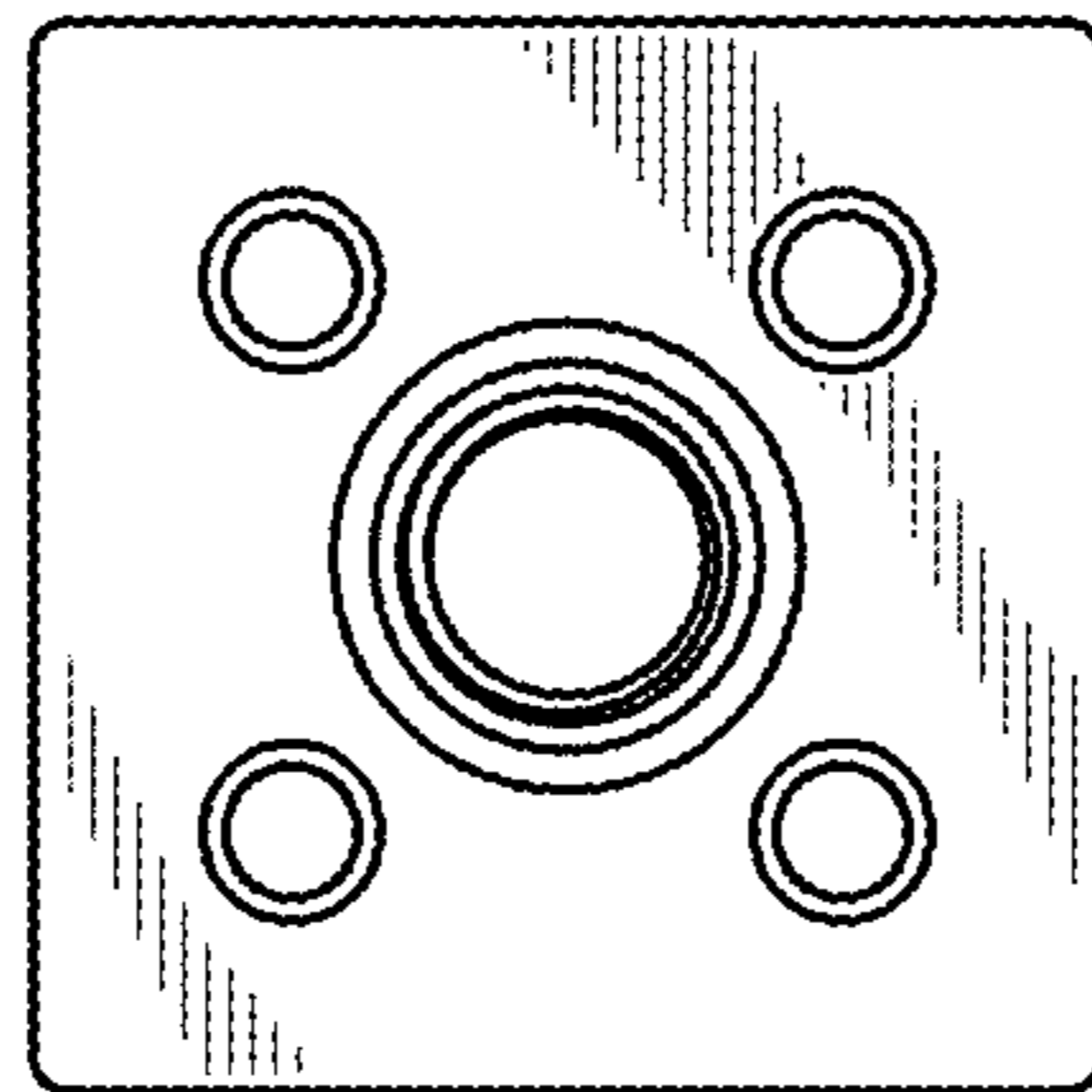

FIG. 8

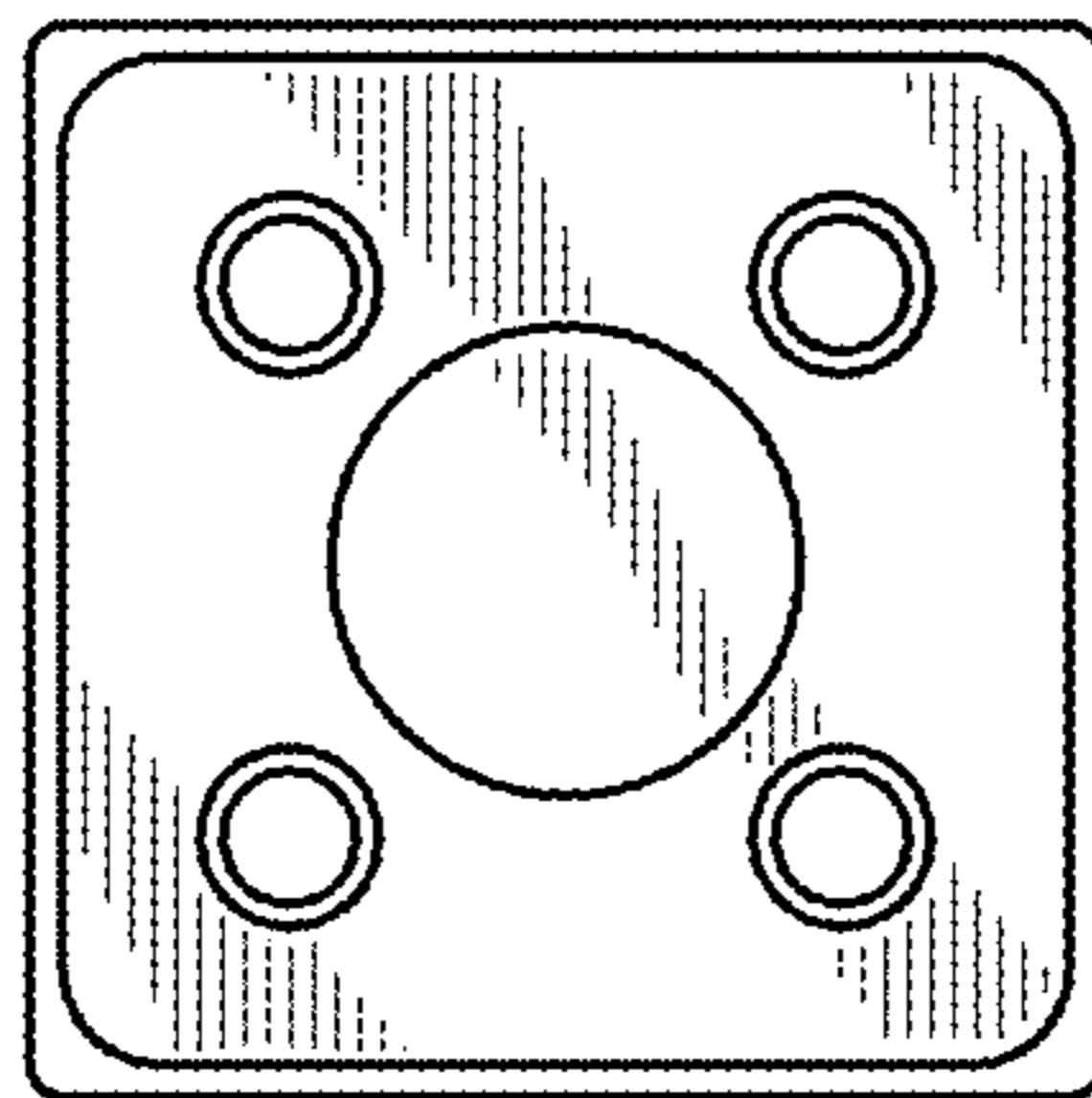

FIG. 9

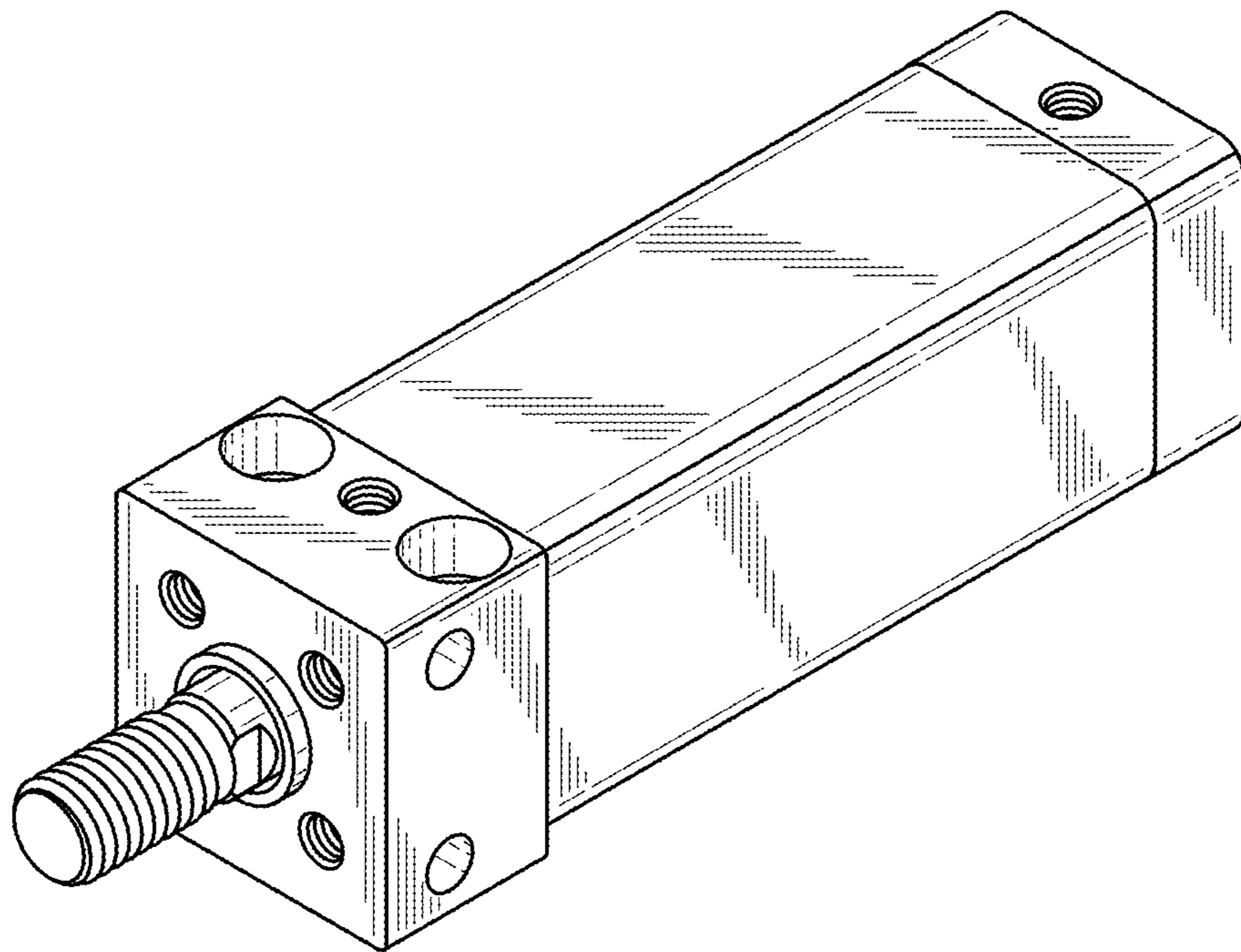

FIG. 10

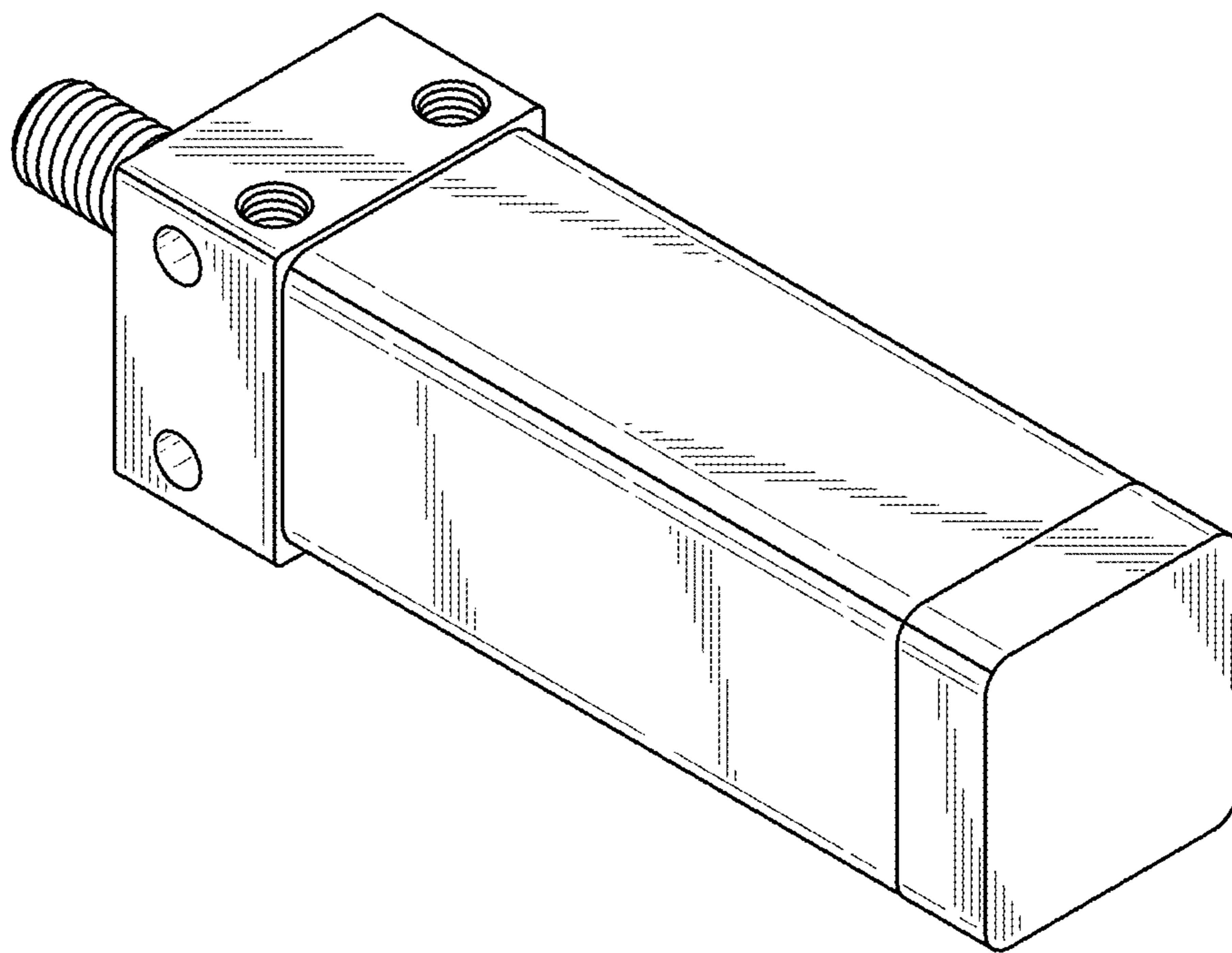

FIG. 11

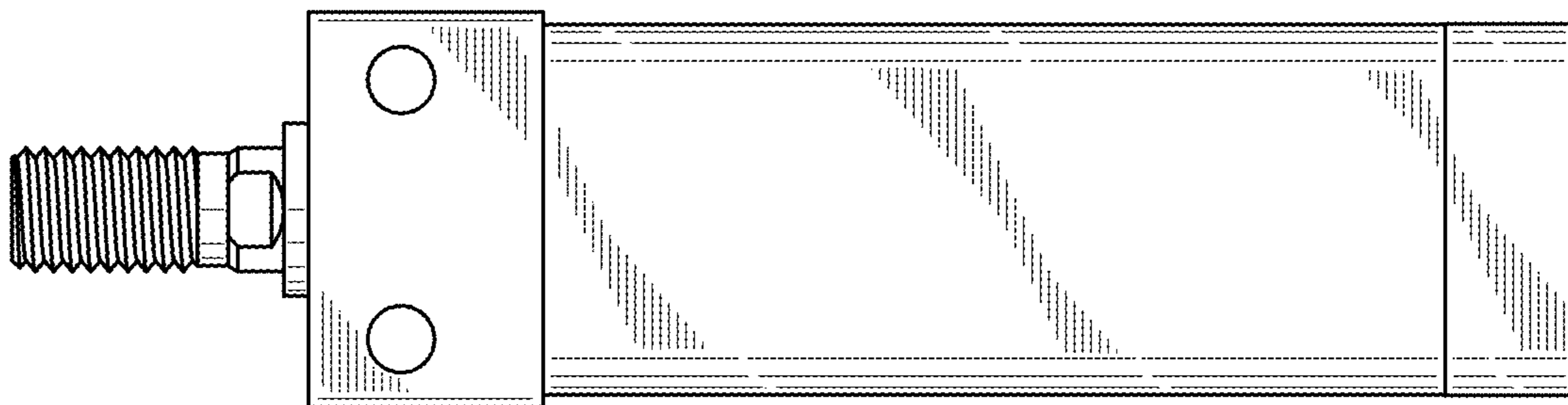

FIG. 12

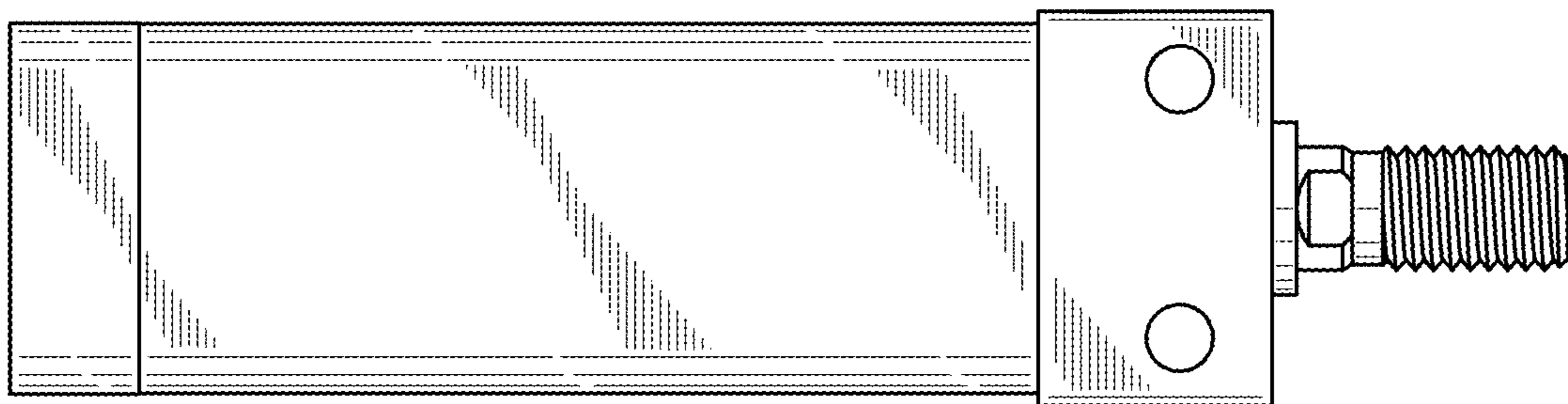



FIG. 13

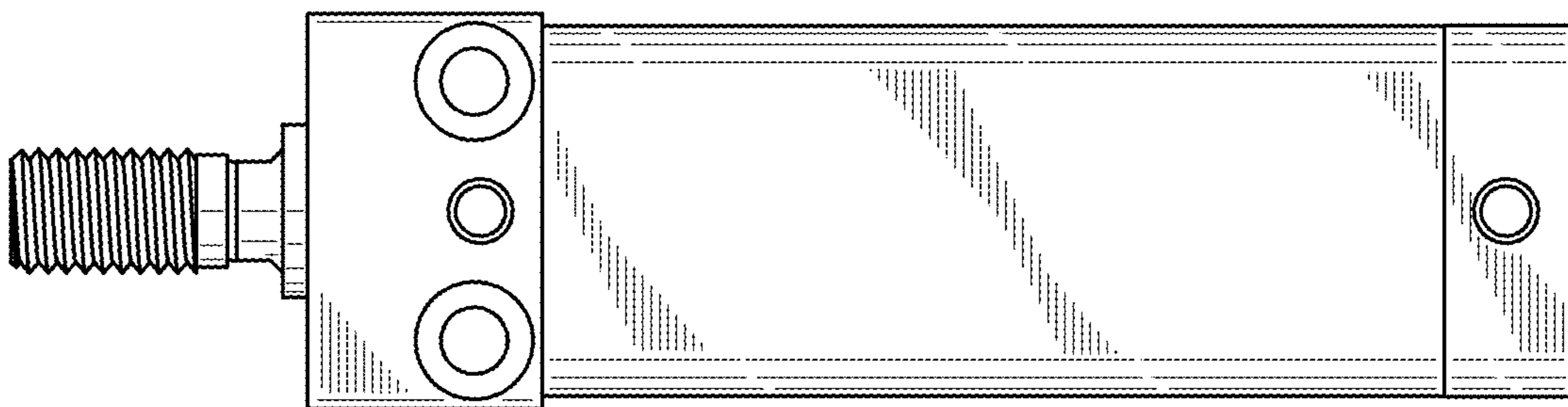

FIG. 14

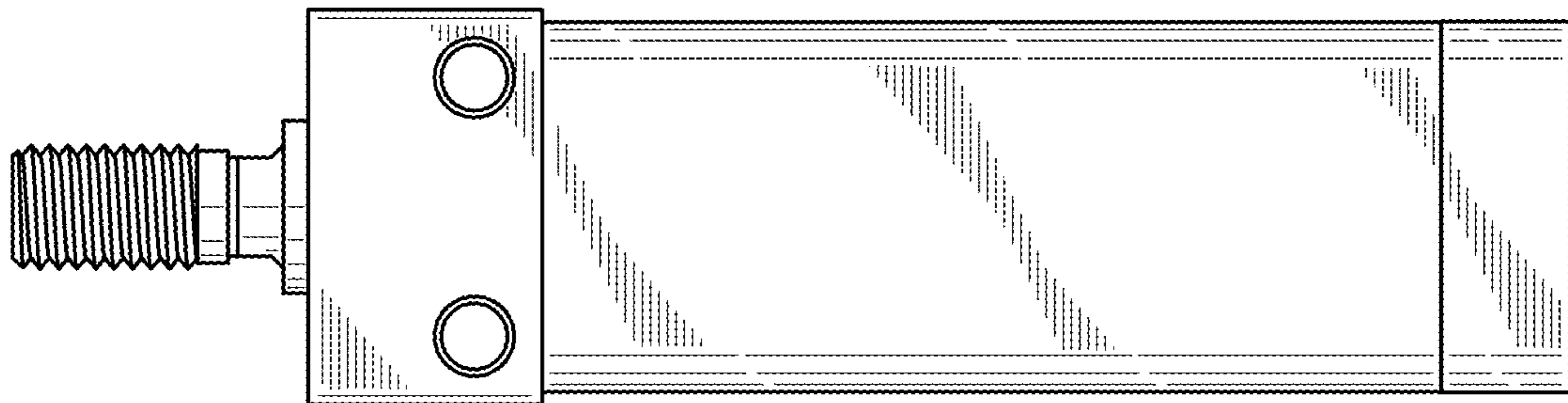

FIG. 15

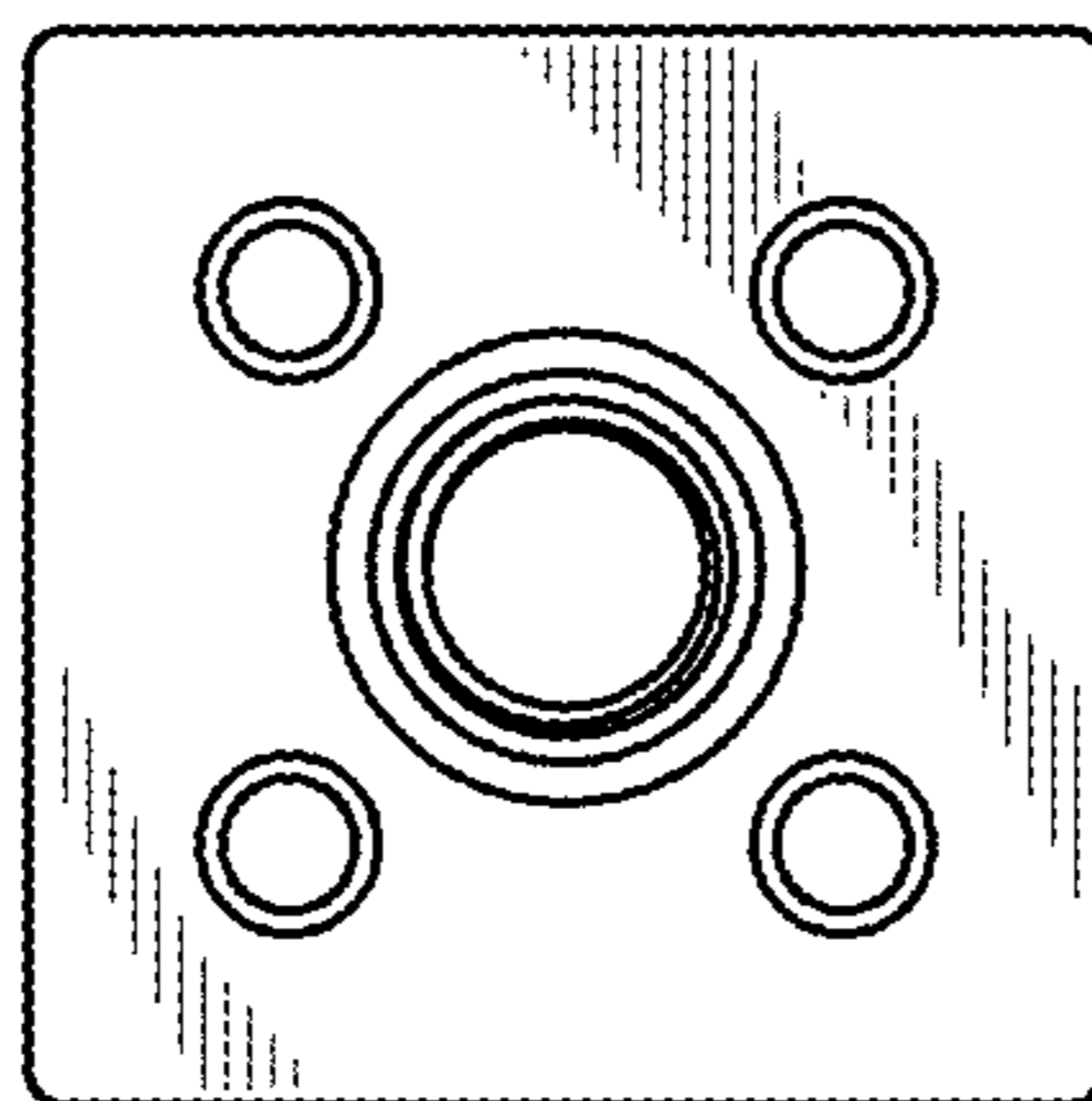

FIG. 16

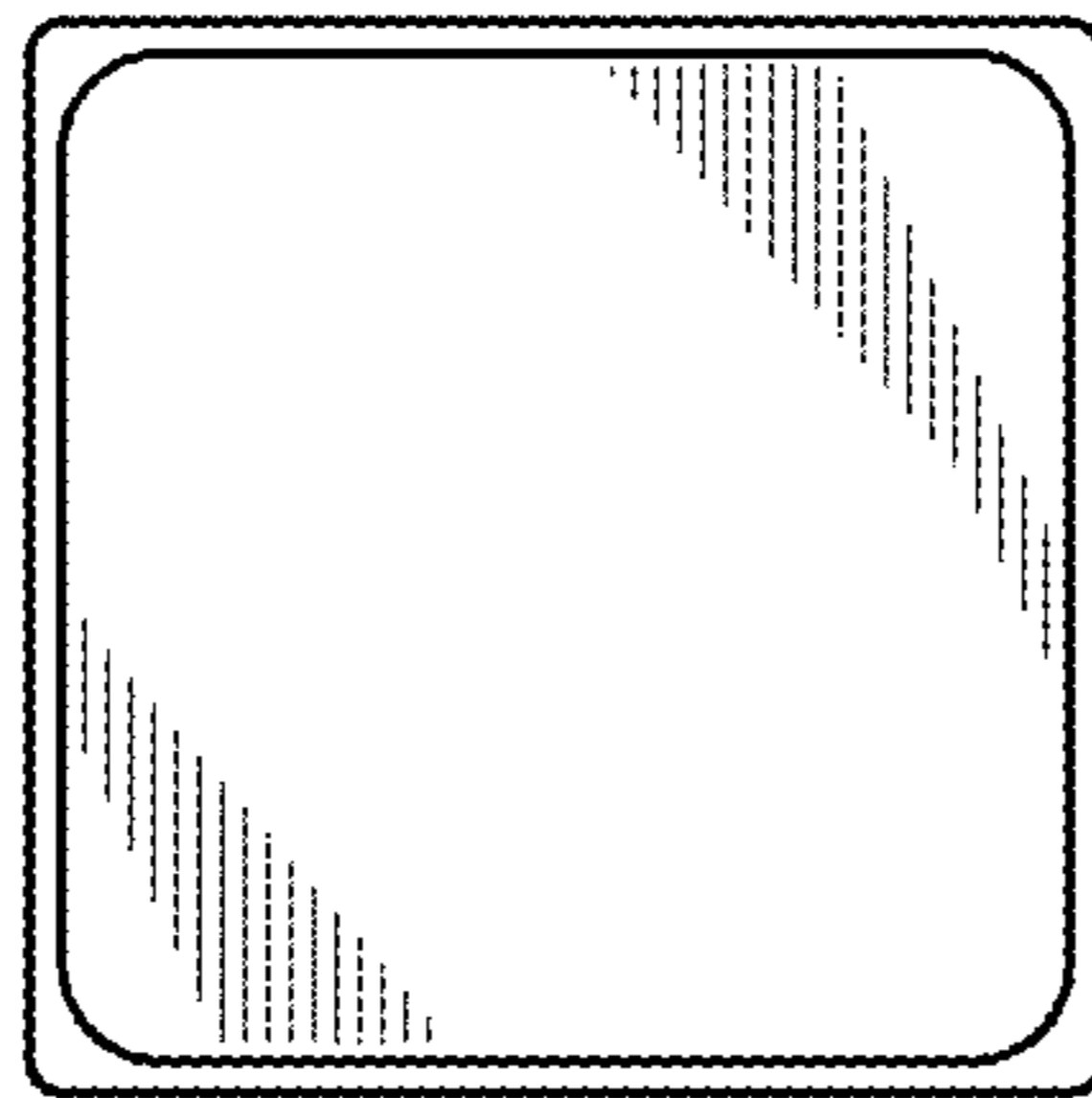

FIG. 17

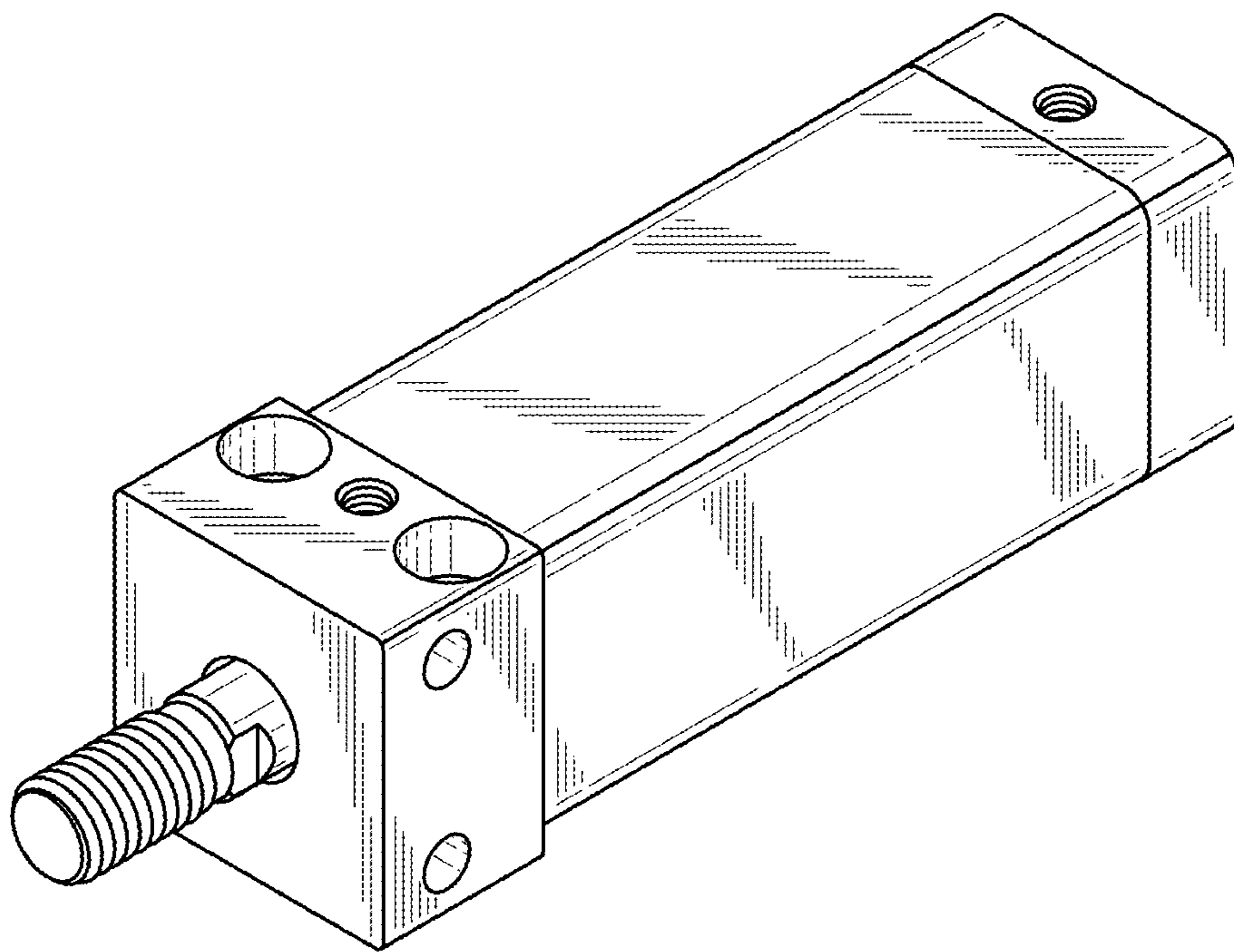

FIG. 18

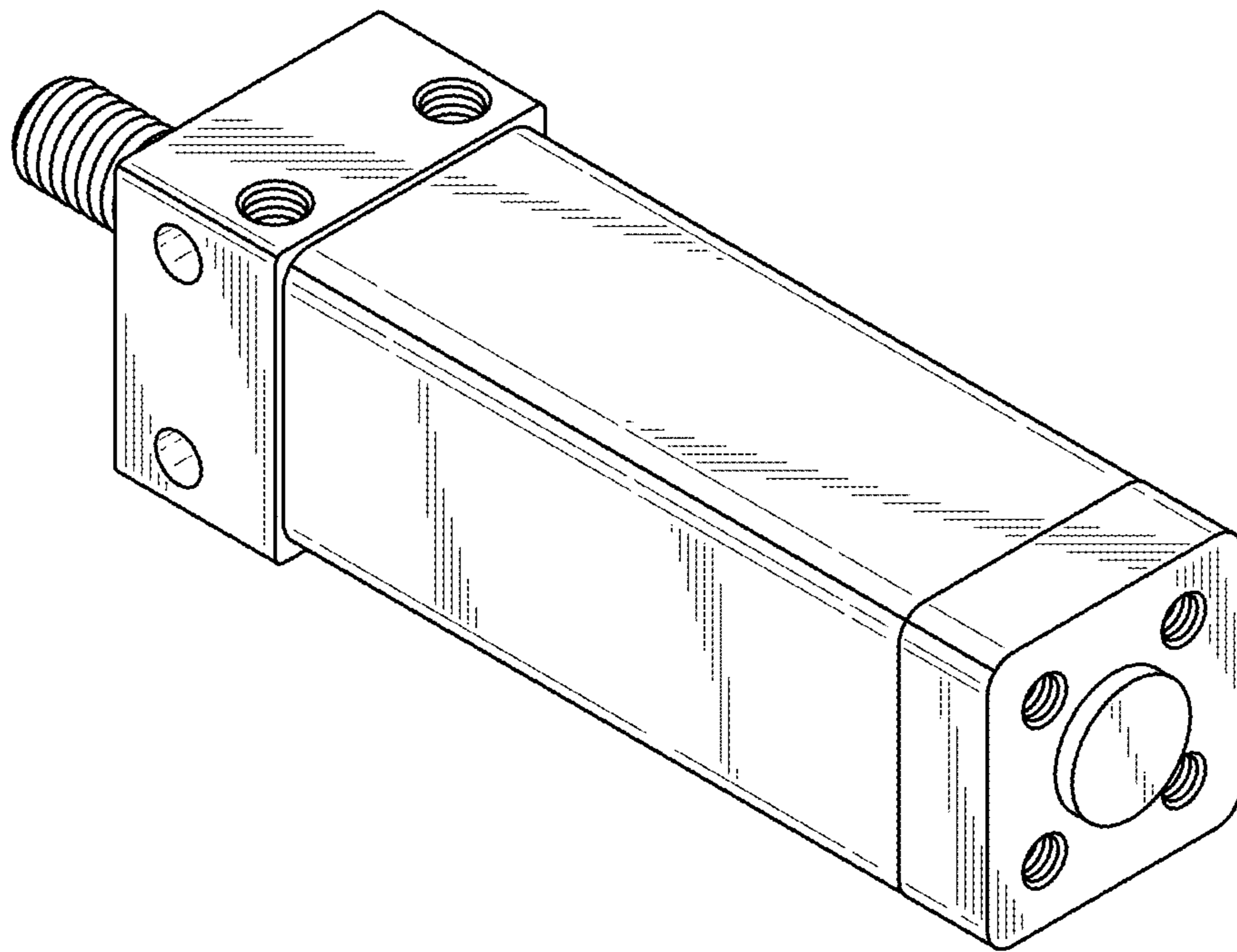



FIG. 19

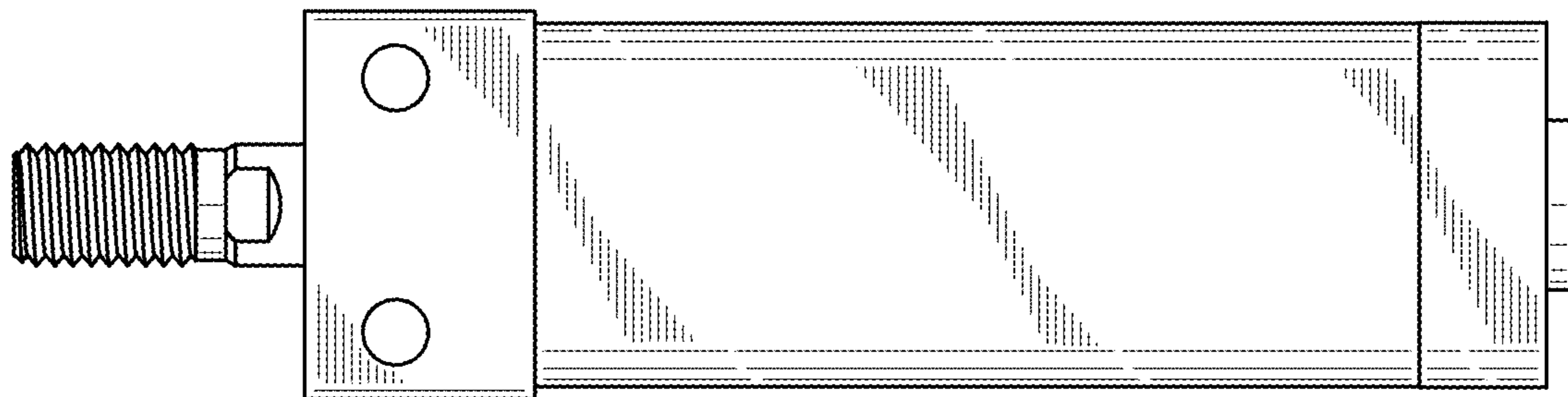

FIG. 20

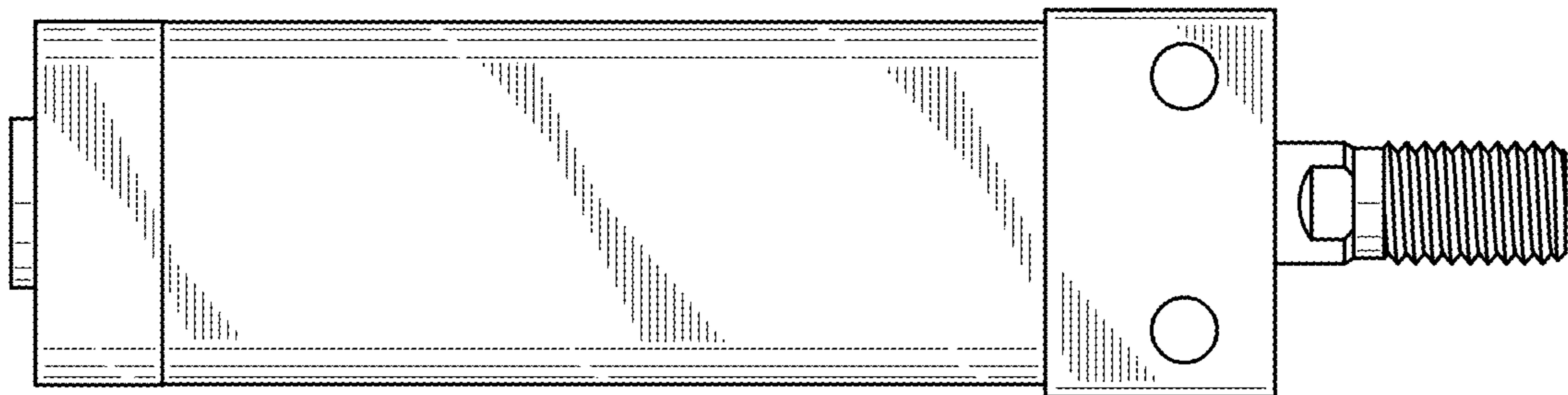

FIG. 21

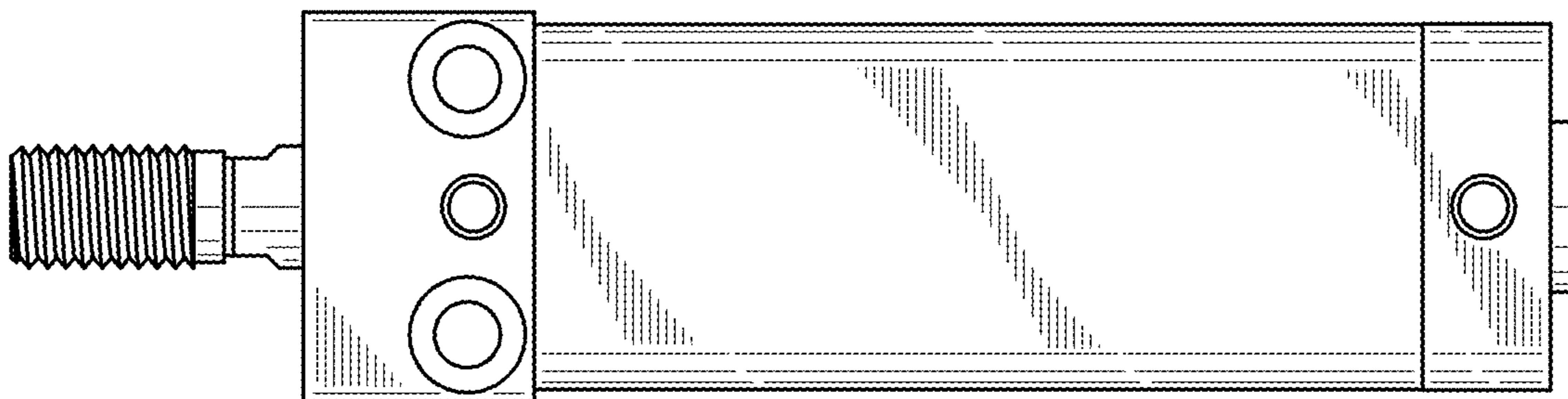

FIG. 22

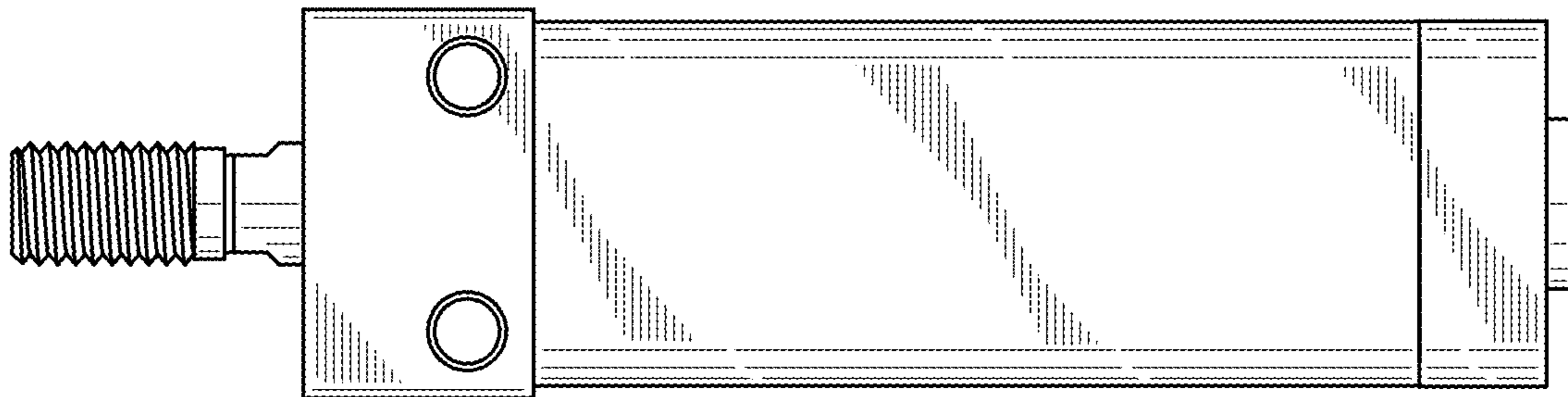

FIG. 23

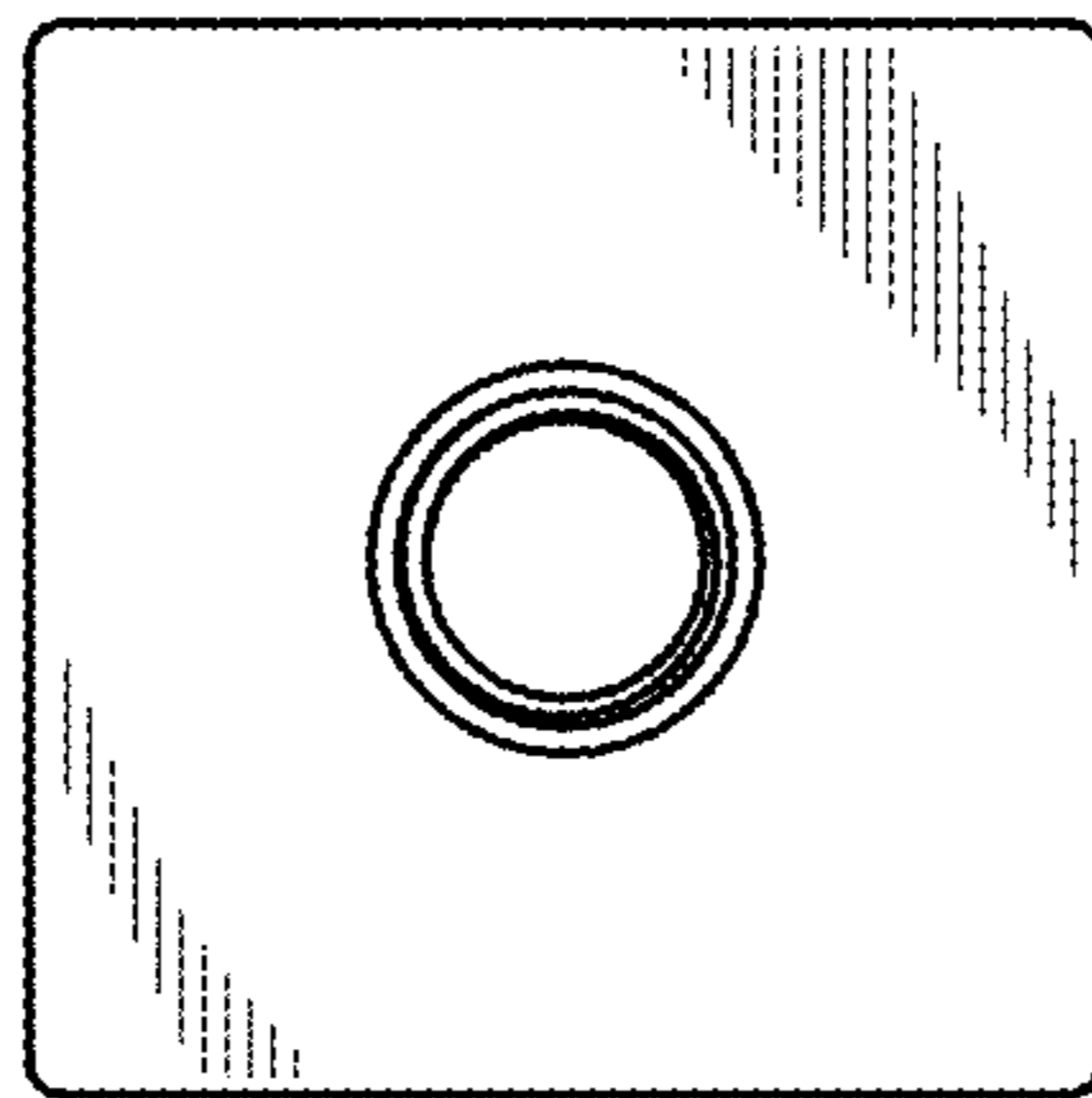

FIG. 24

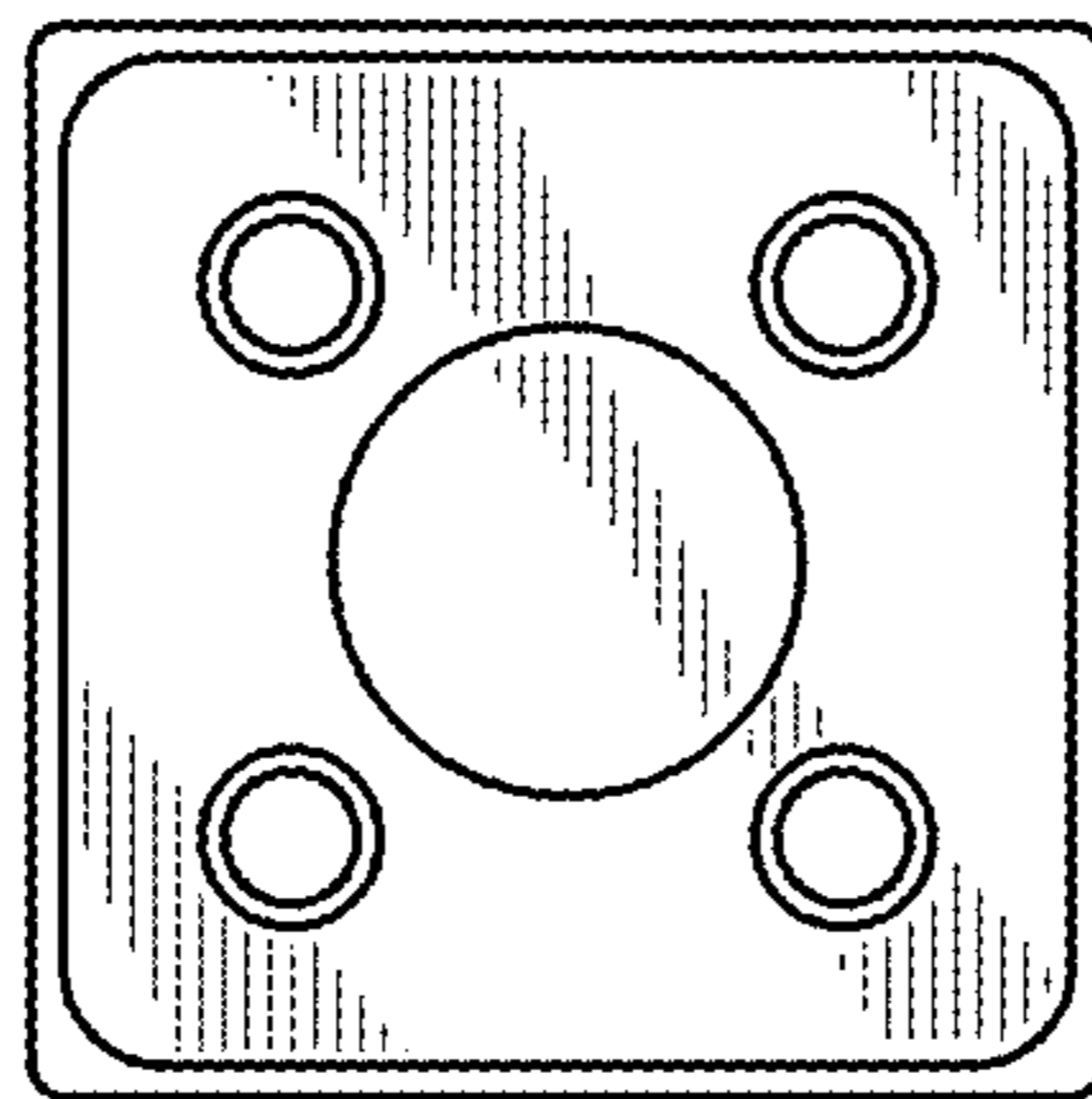



FIG. 25

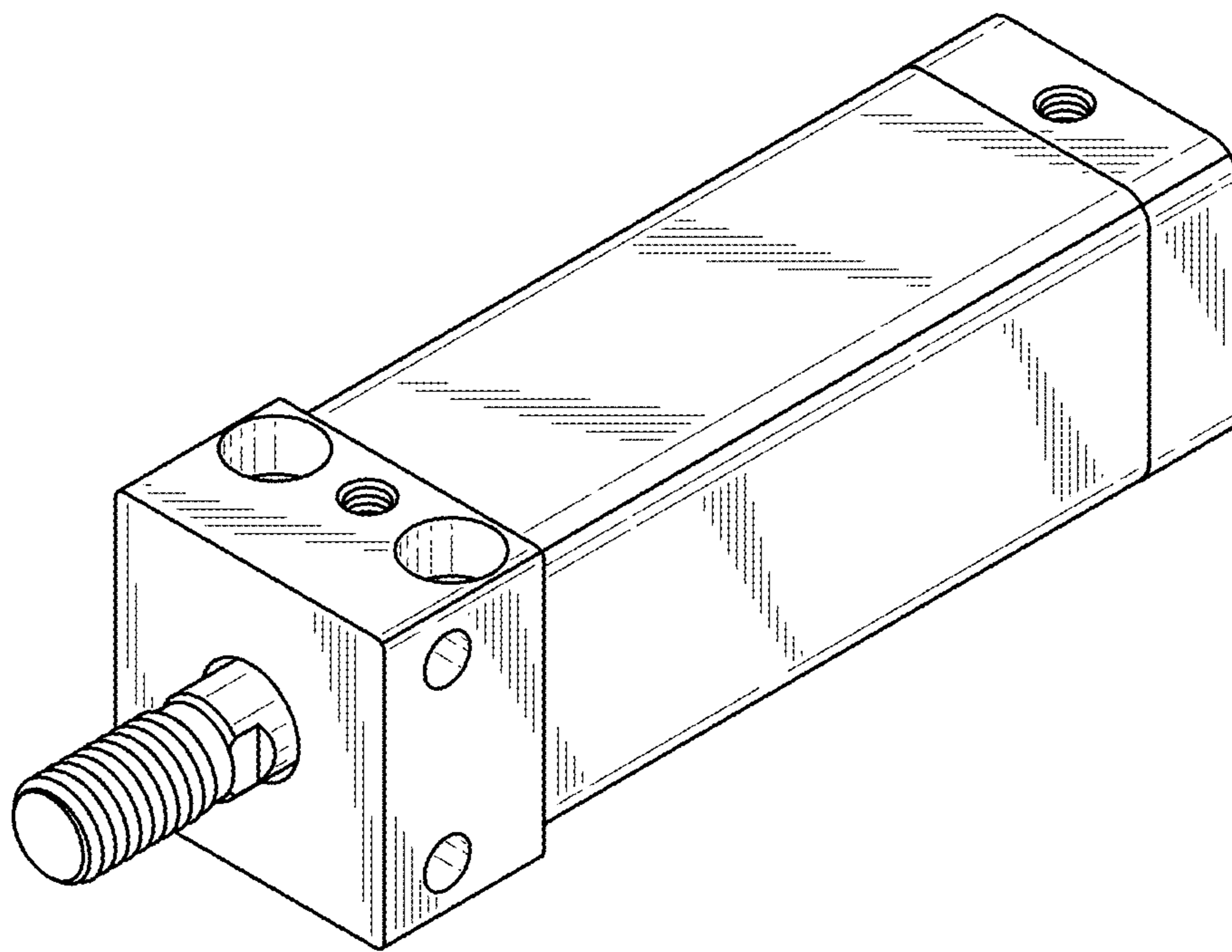

FIG. 26

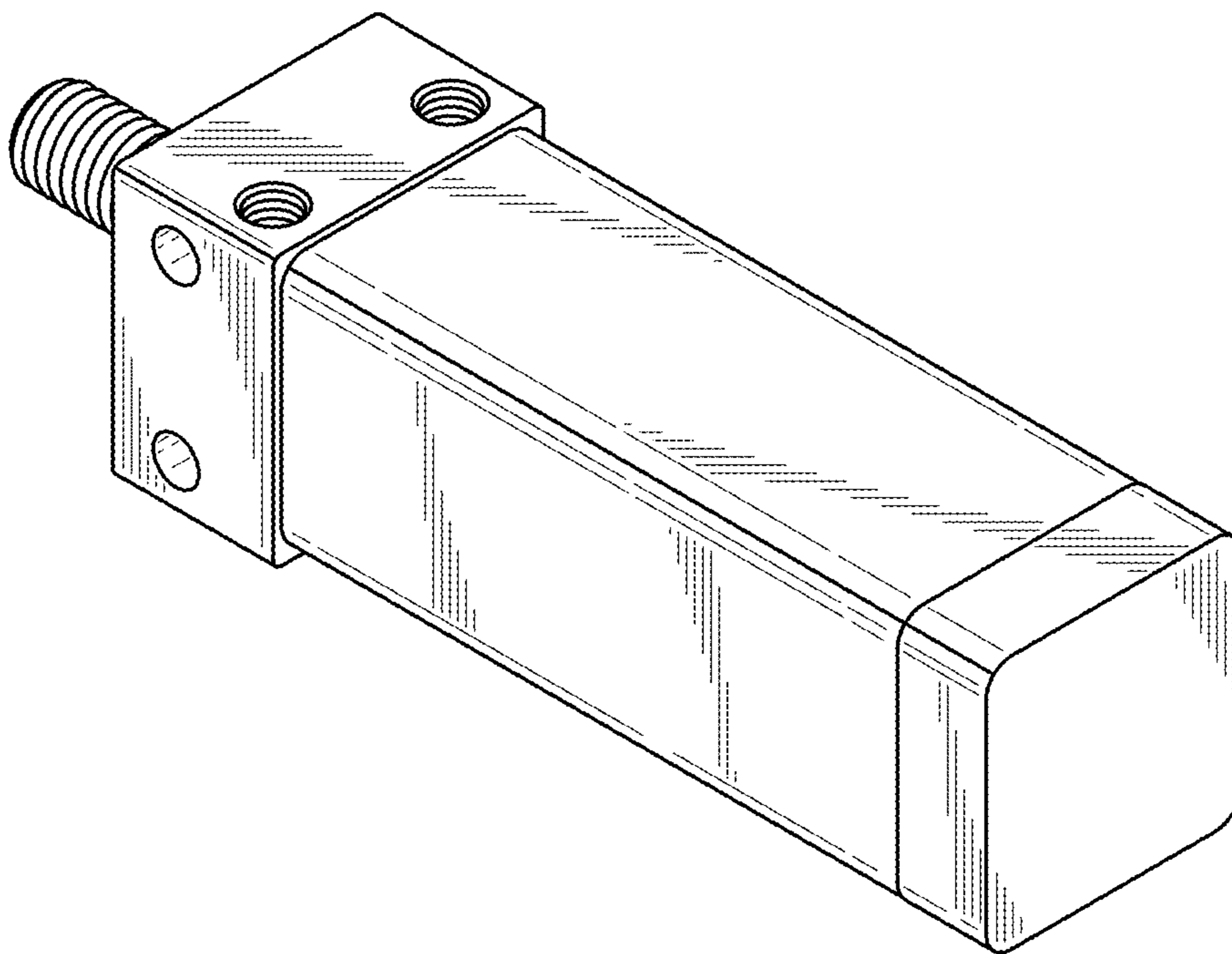

FIG. 27

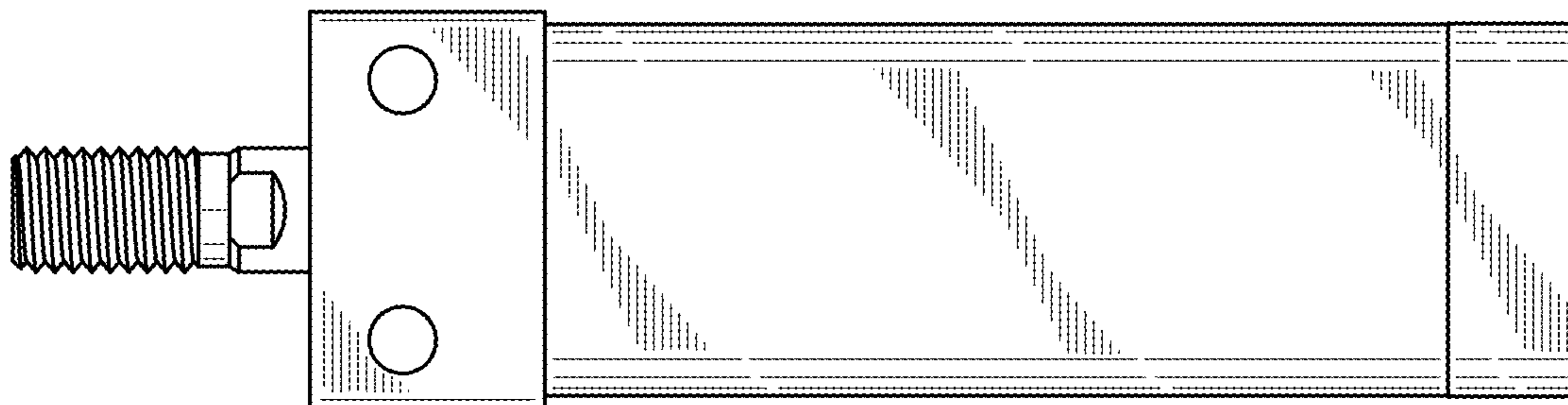

FIG. 28

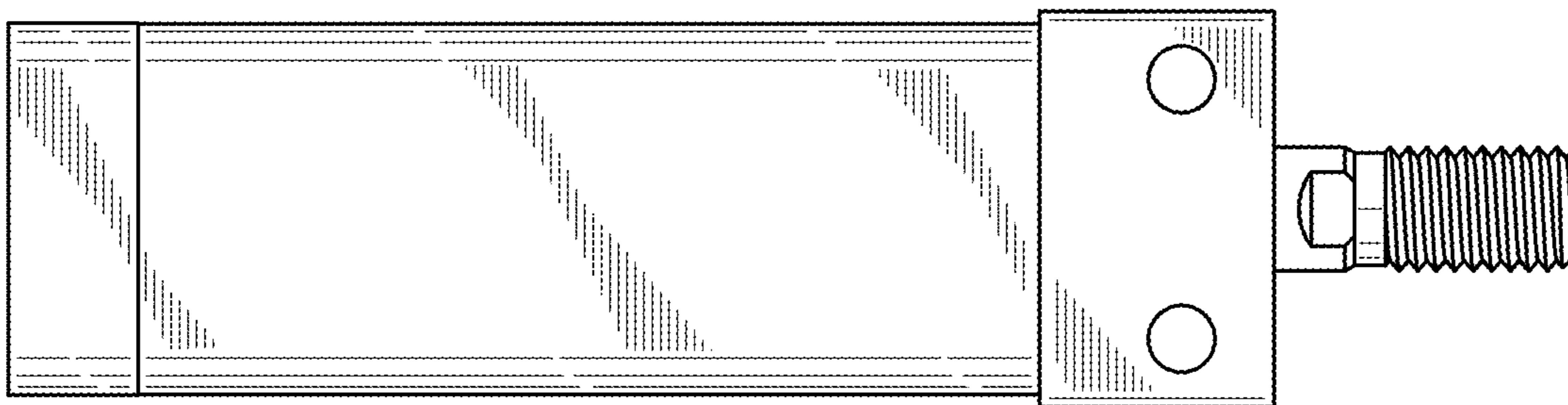

FIG. 29

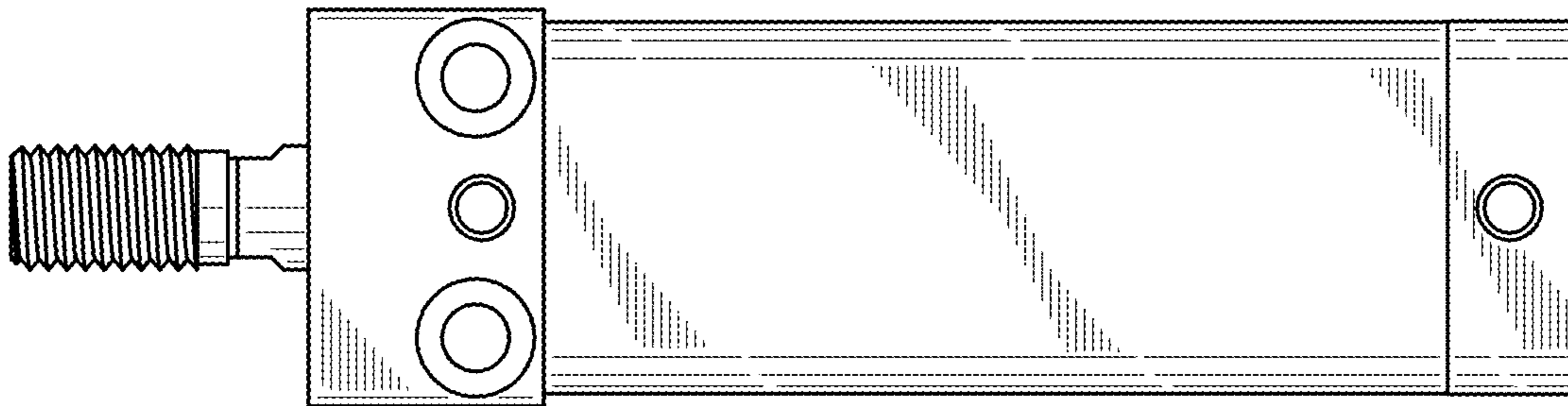

FIG. 30

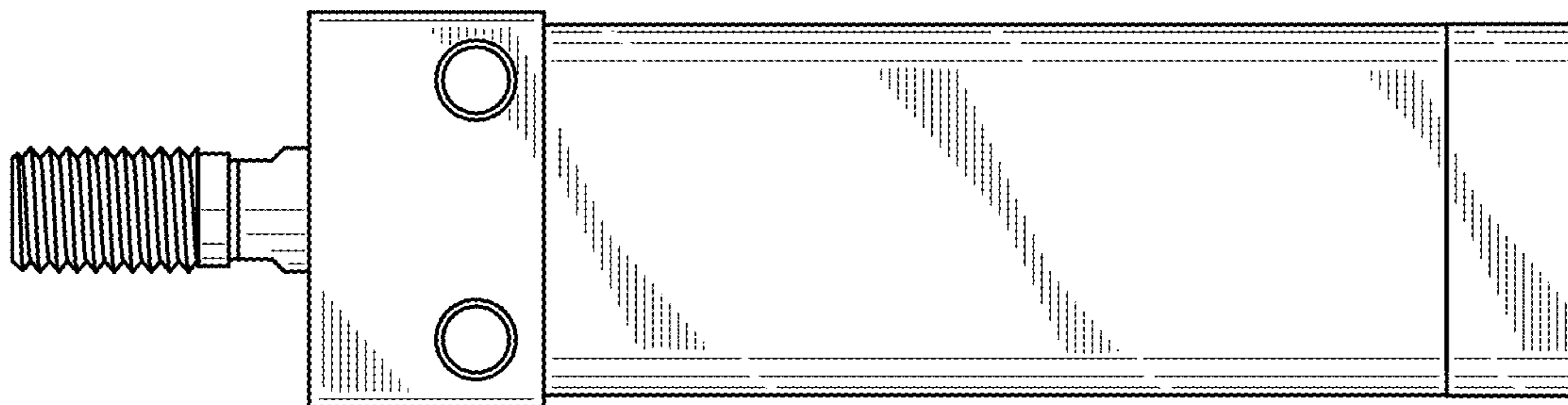



FIG. 31

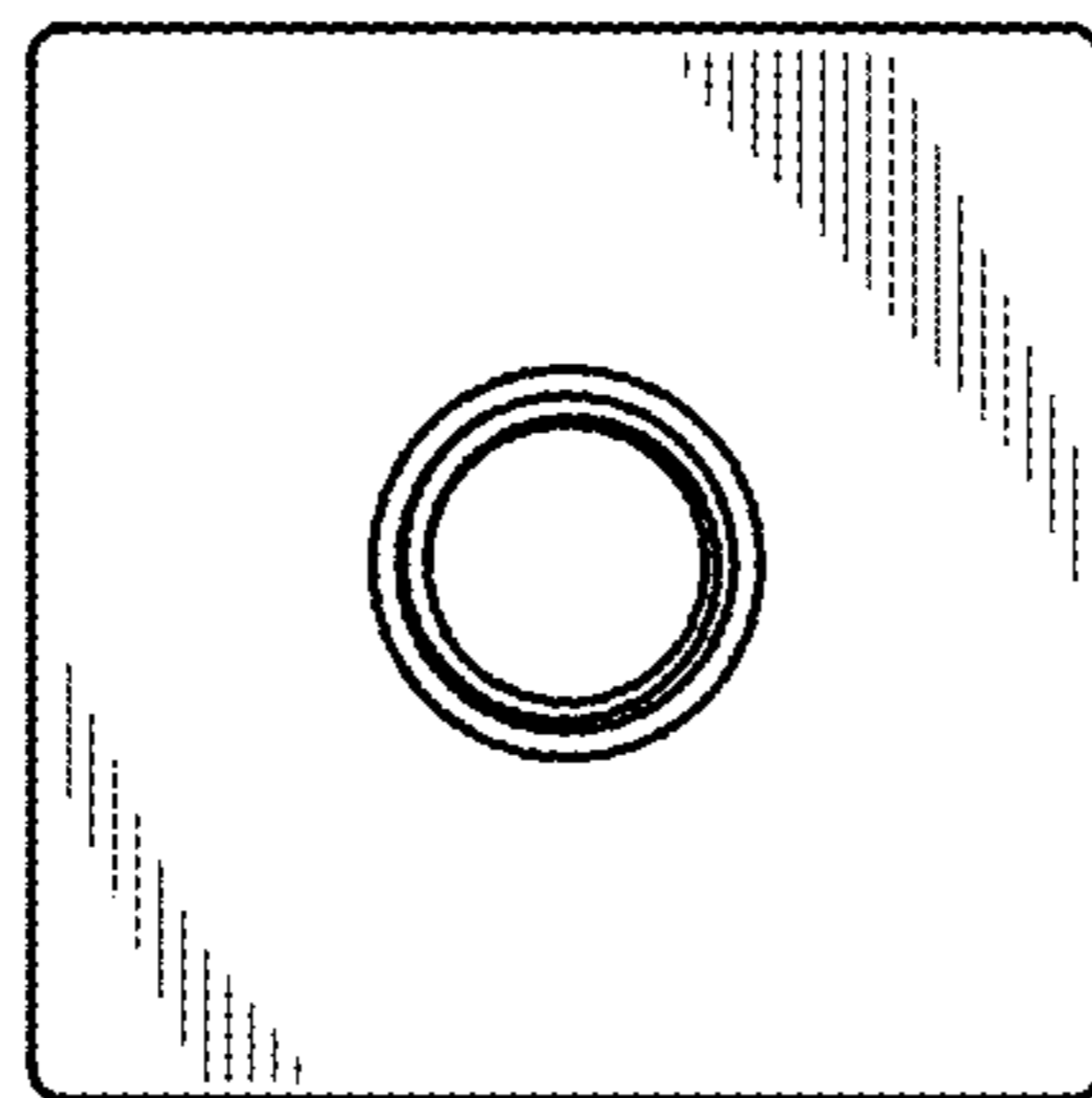

FIG. 32

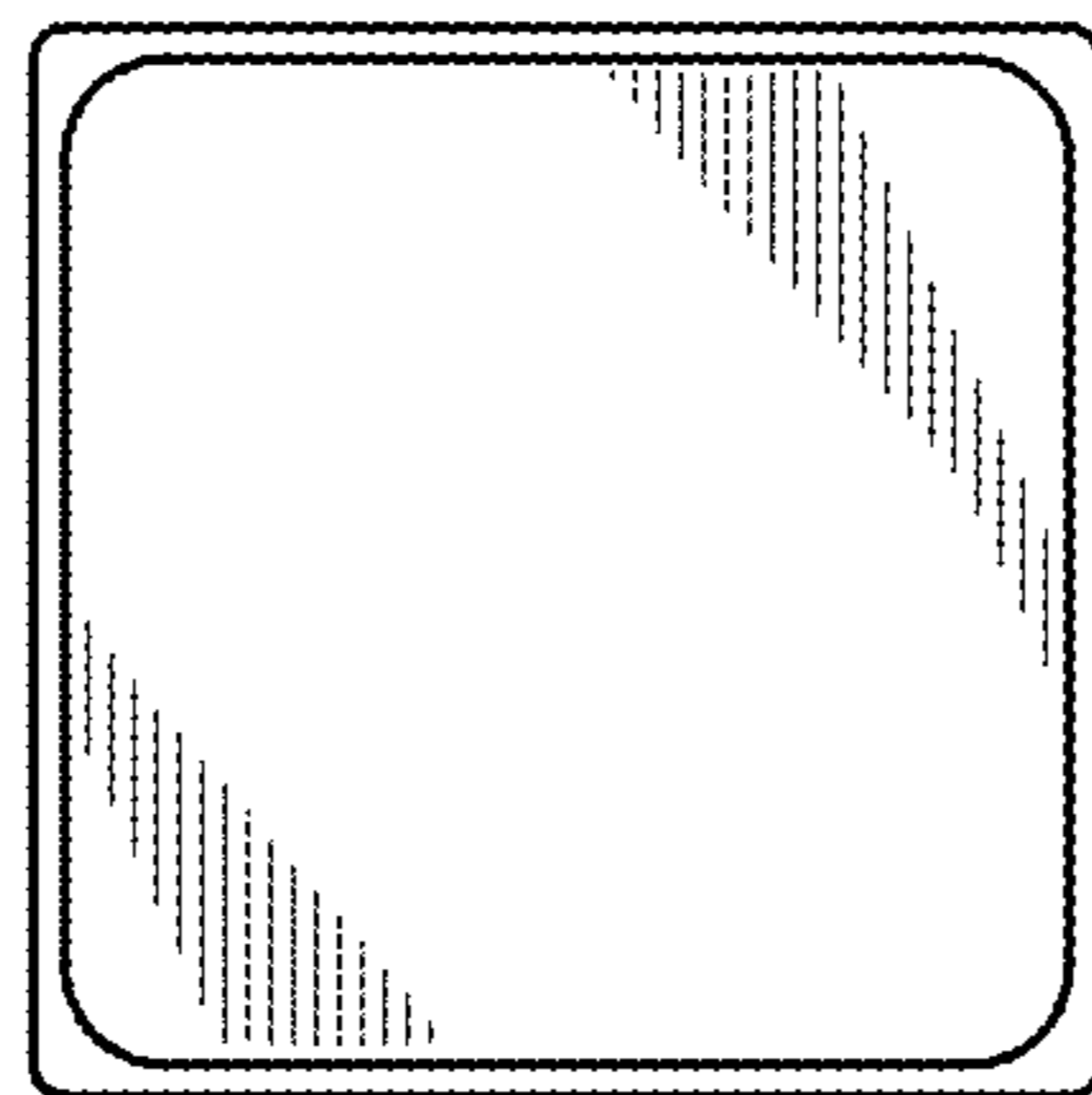

FIG. 33

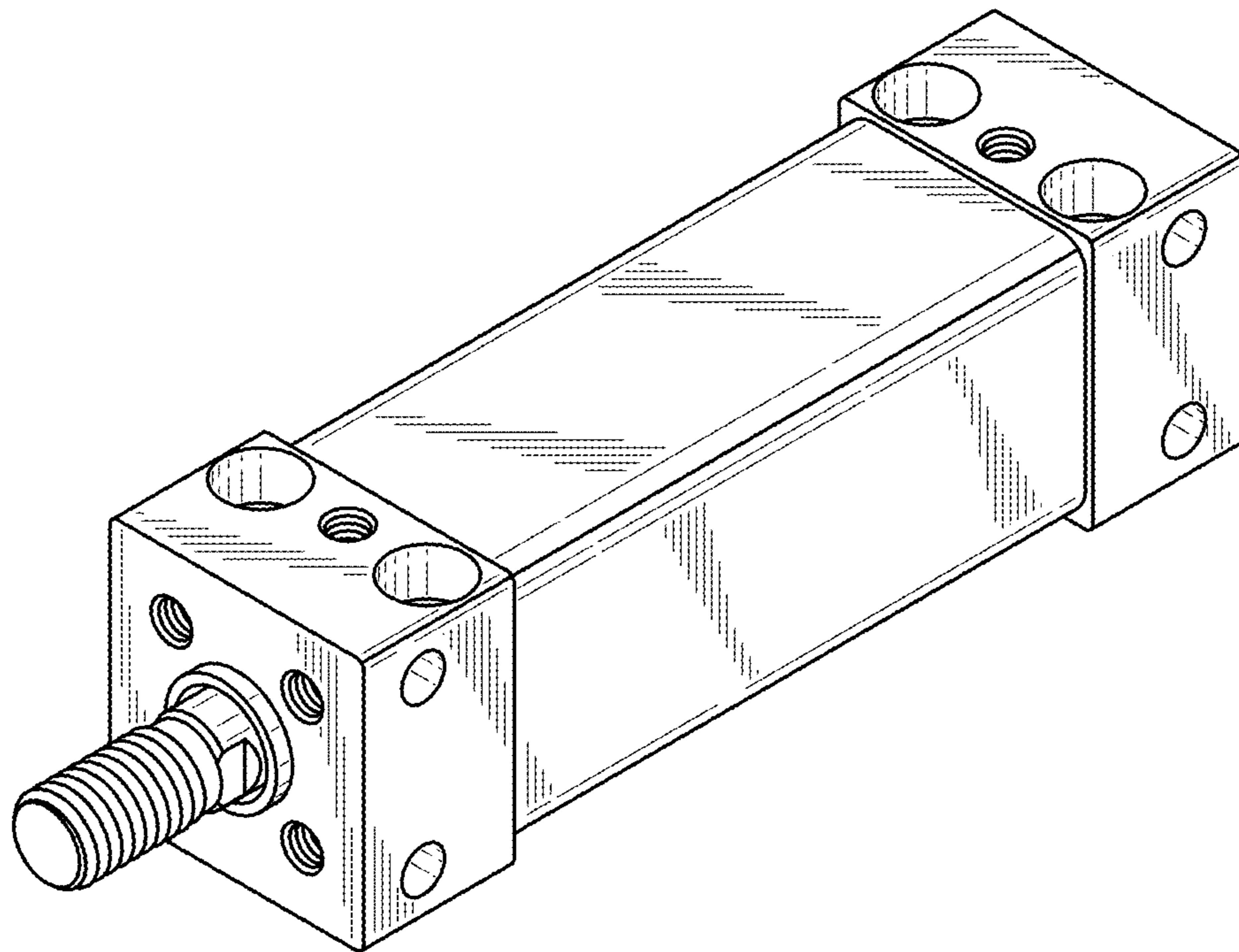

FIG. 34

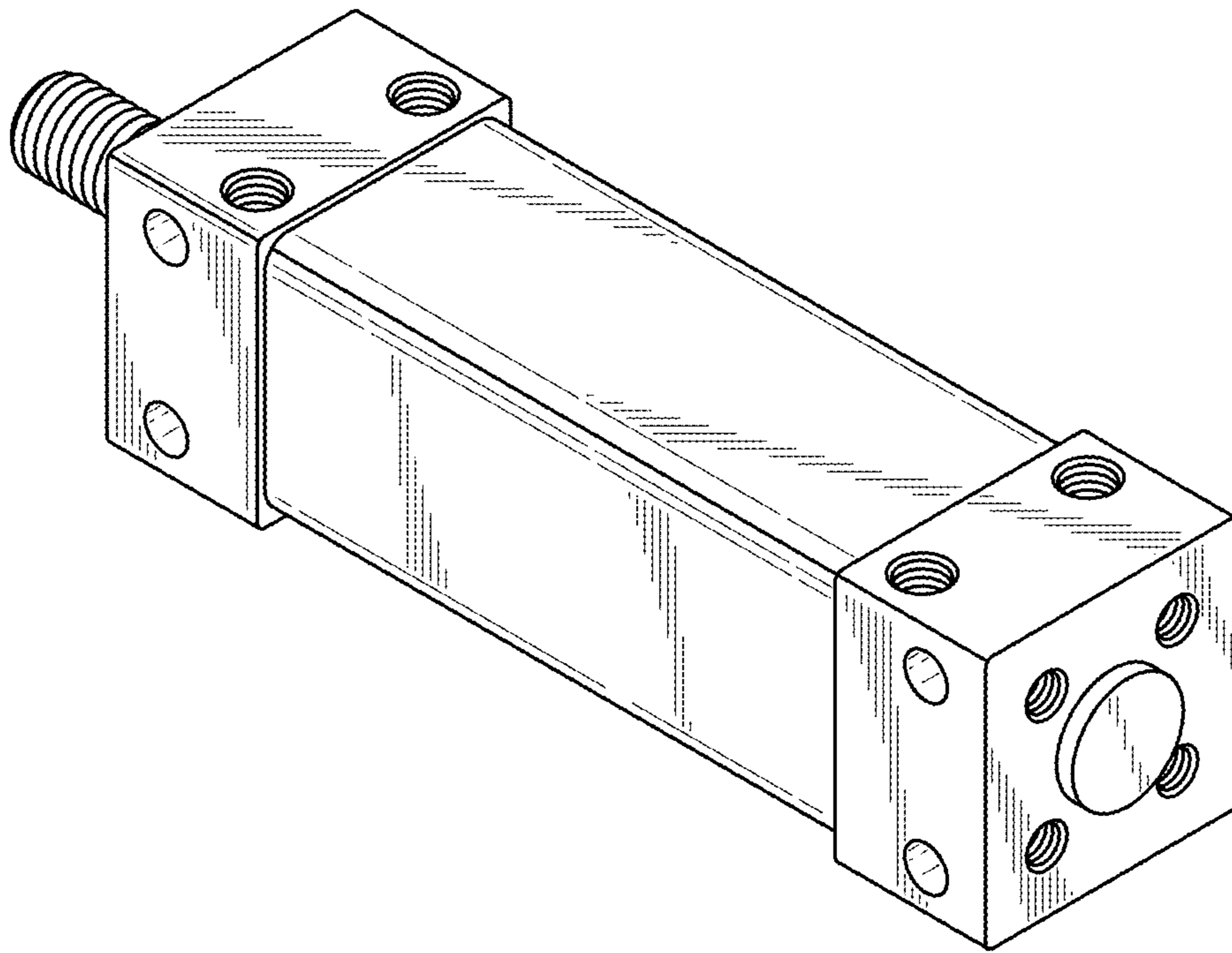

FIG. 35

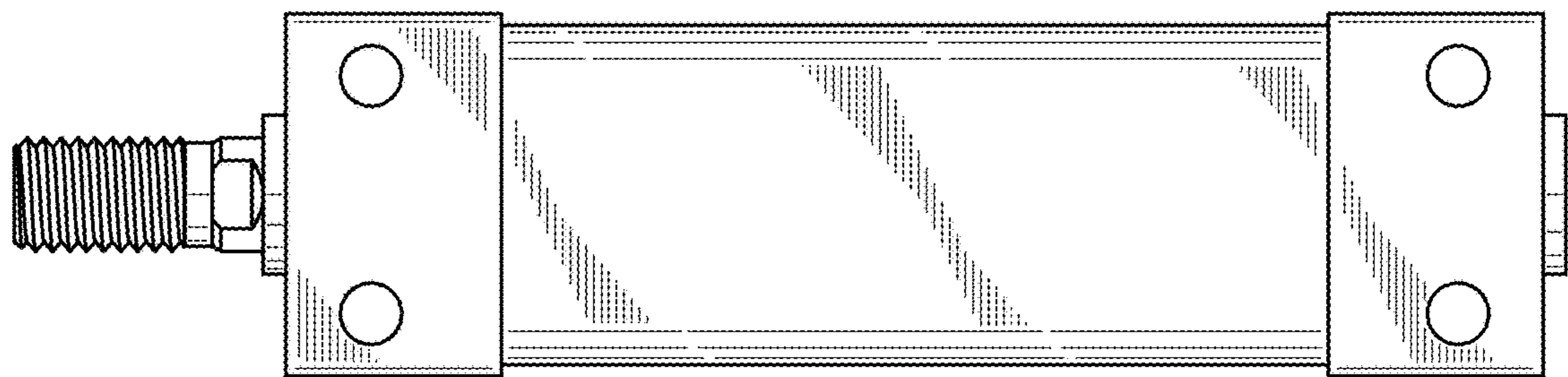

FIG. 36

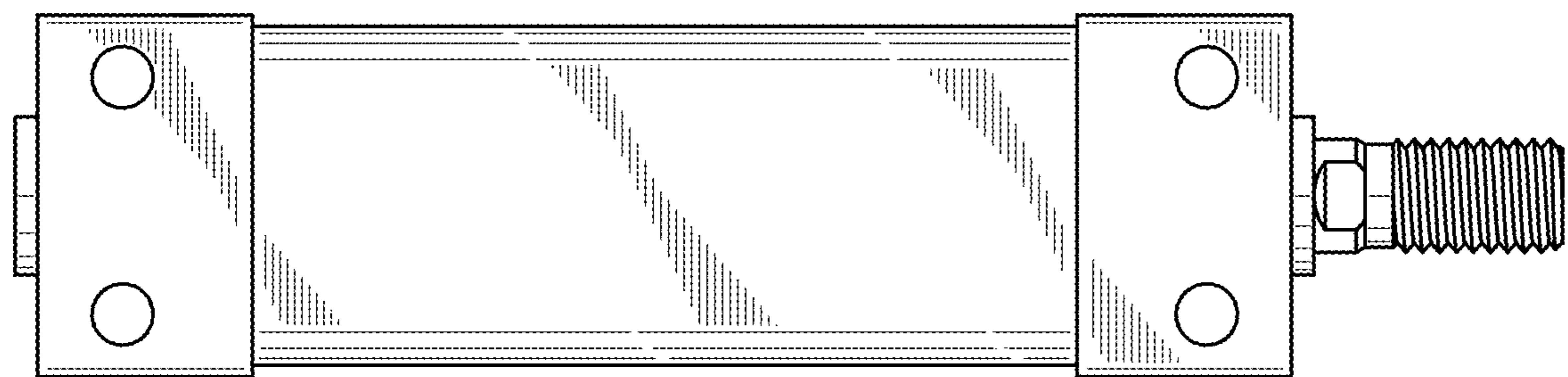

FIG. 37

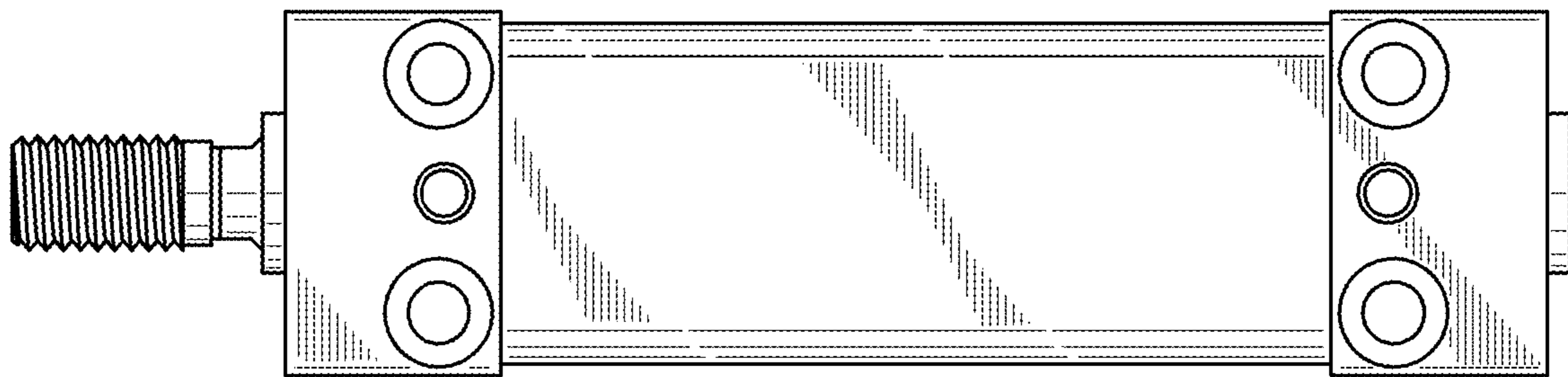

FIG. 38

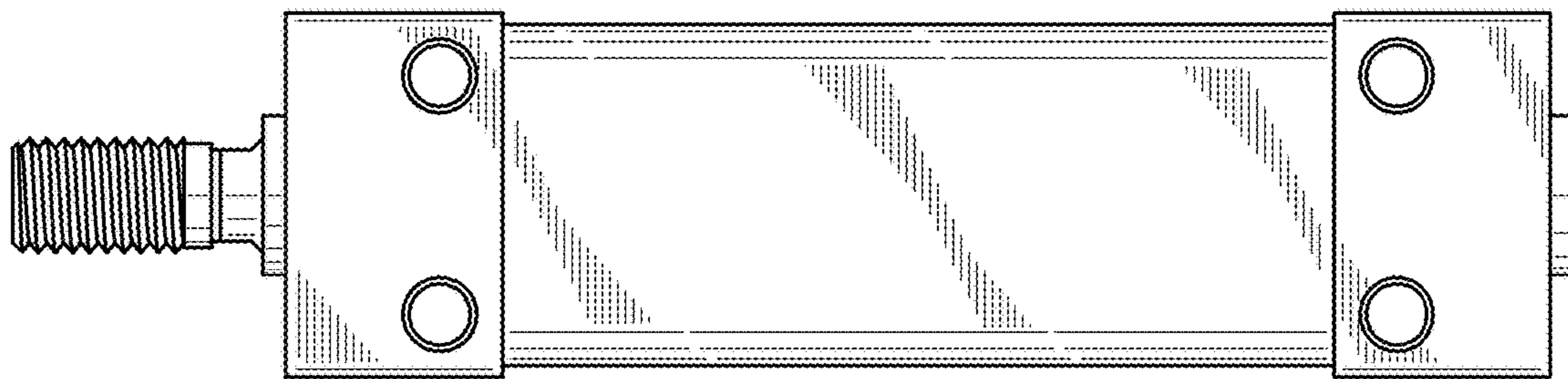



FIG. 39

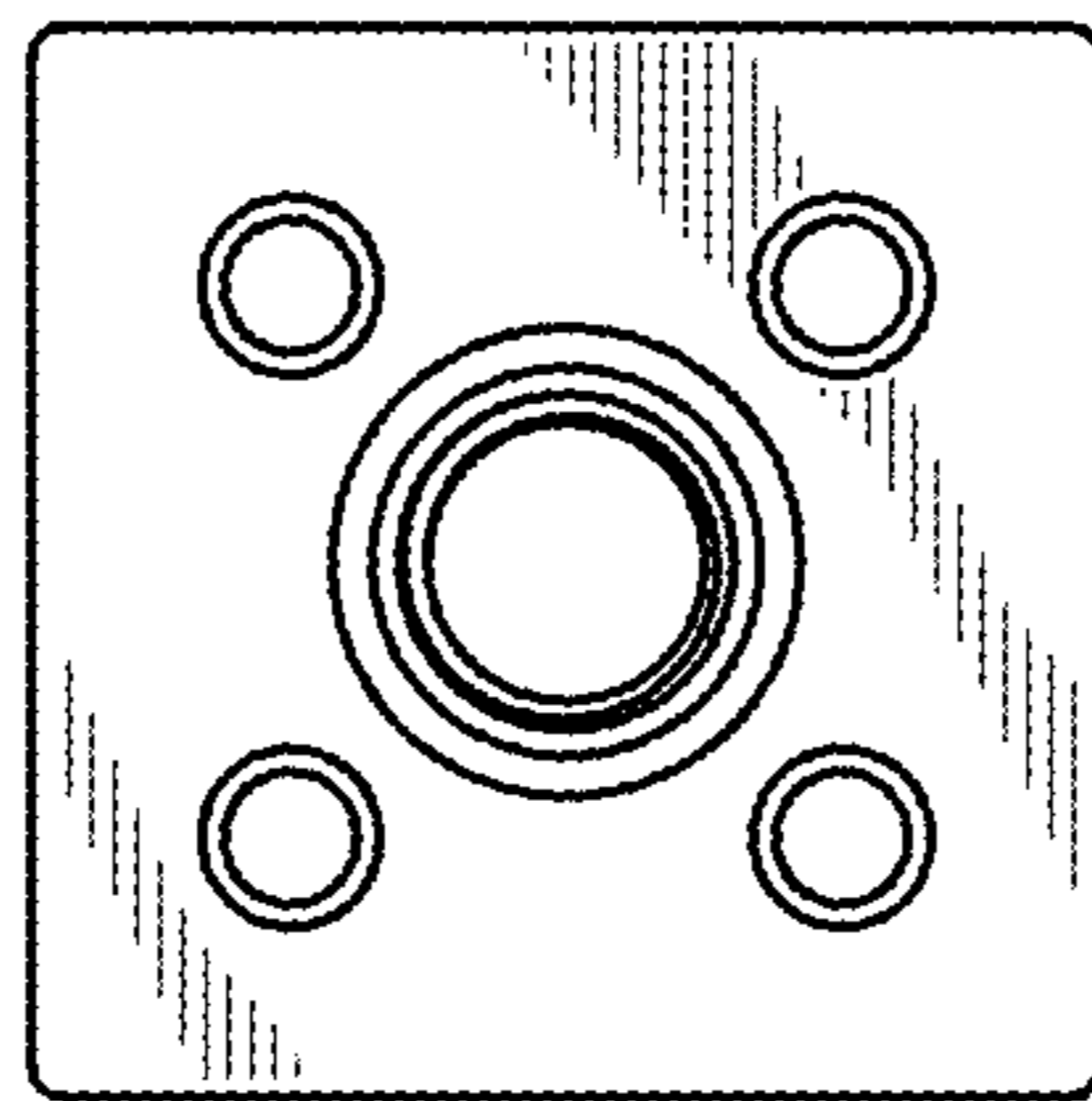

FIG. 40

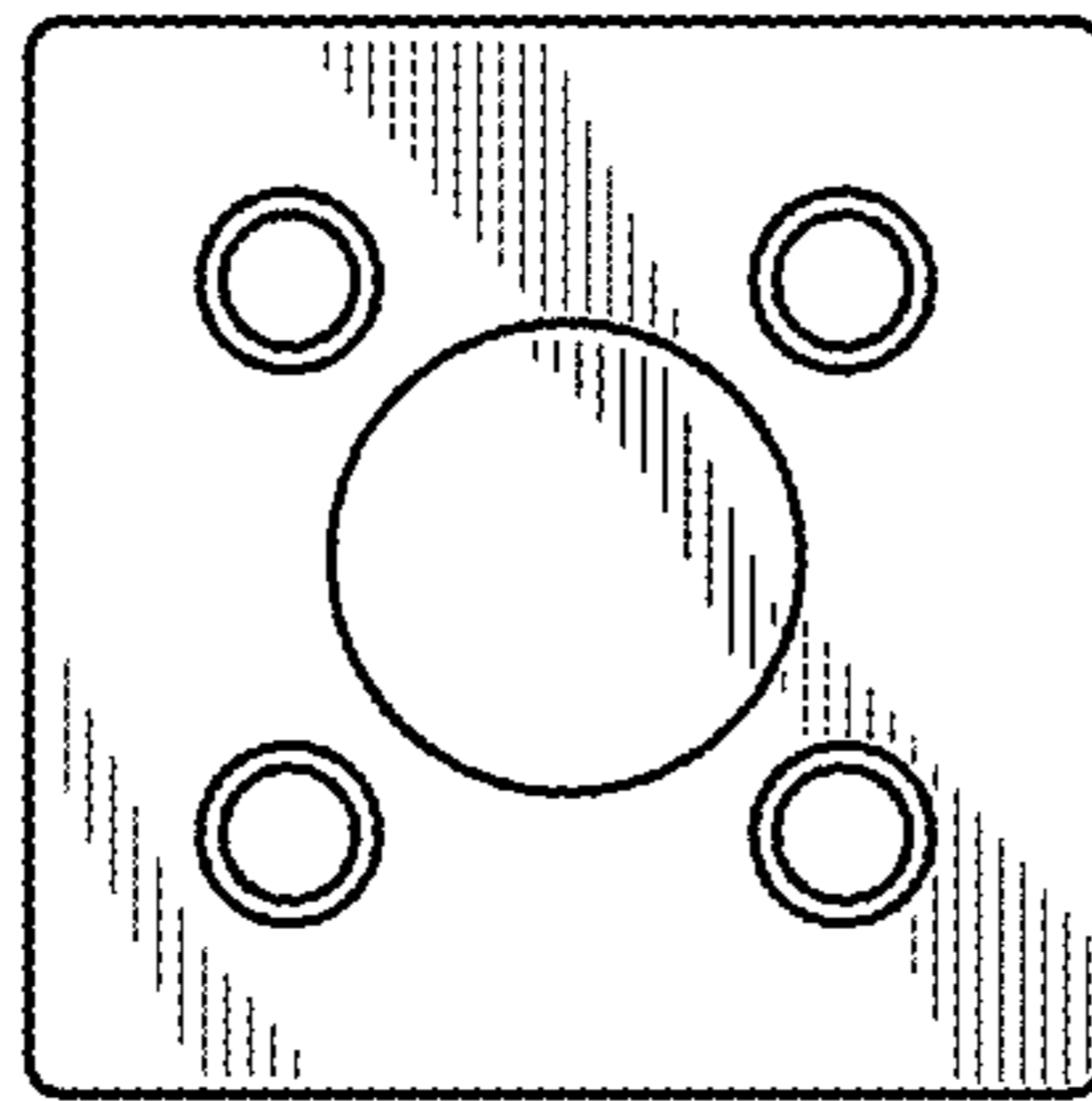

FIG. 41

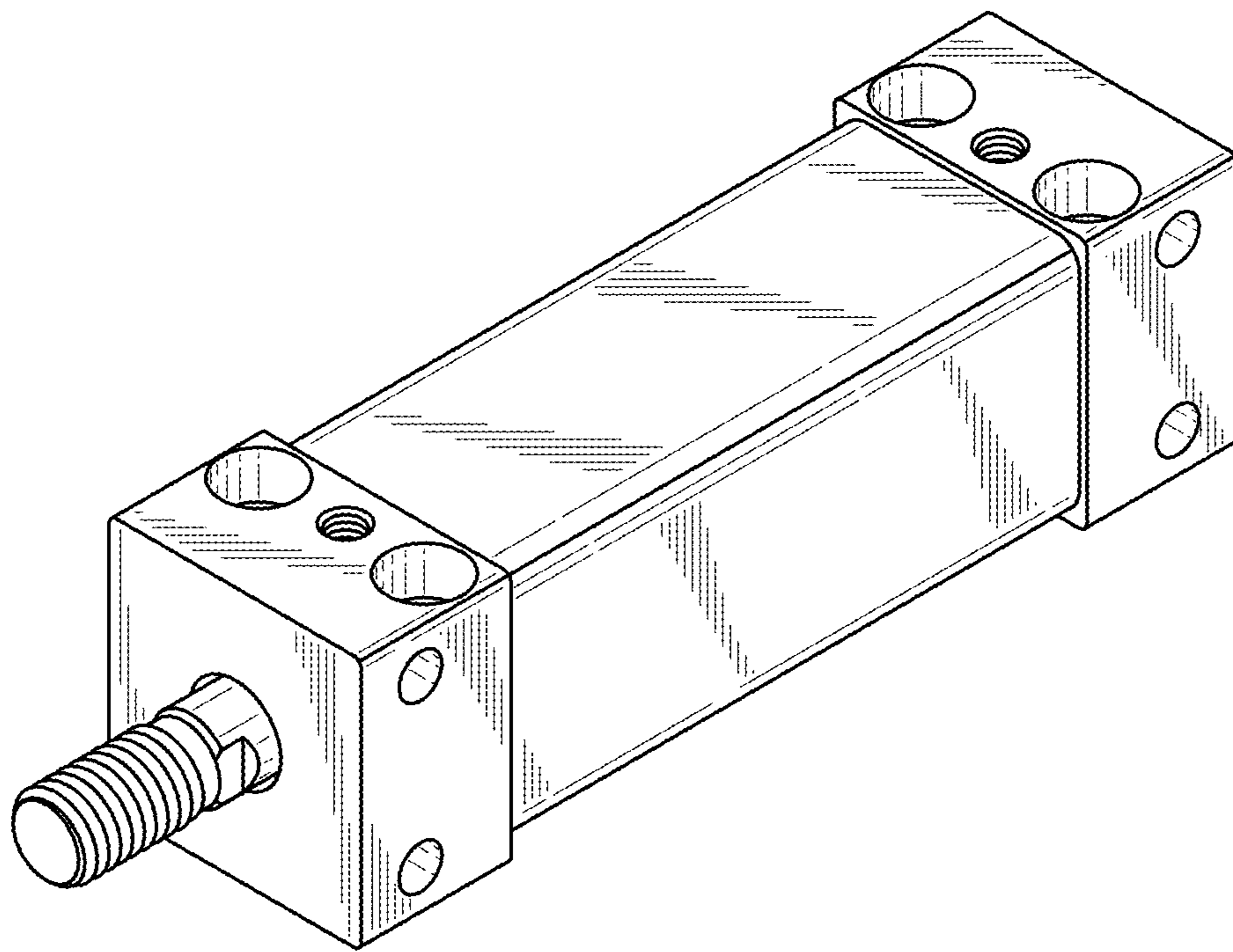

FIG. 42

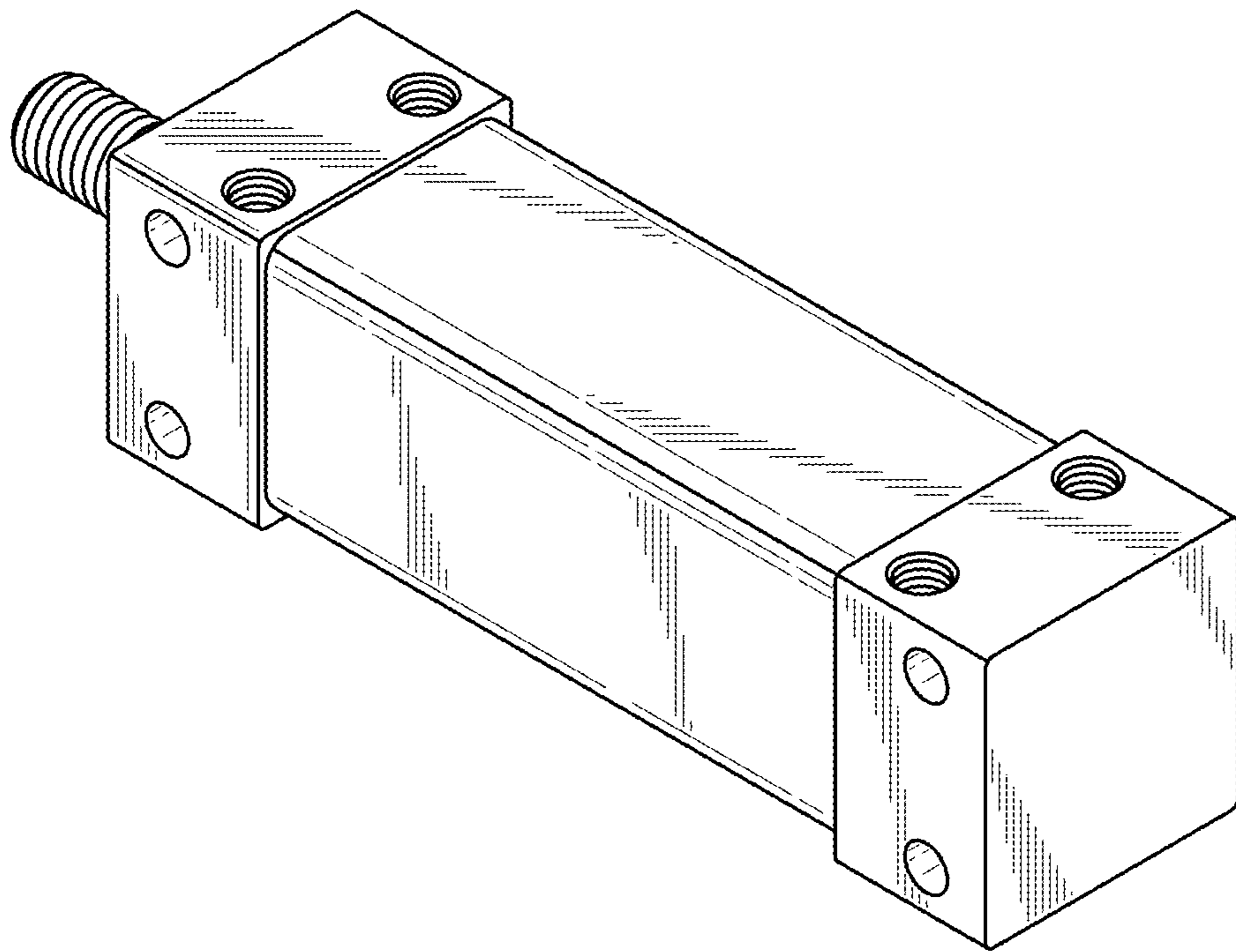

FIG. 43

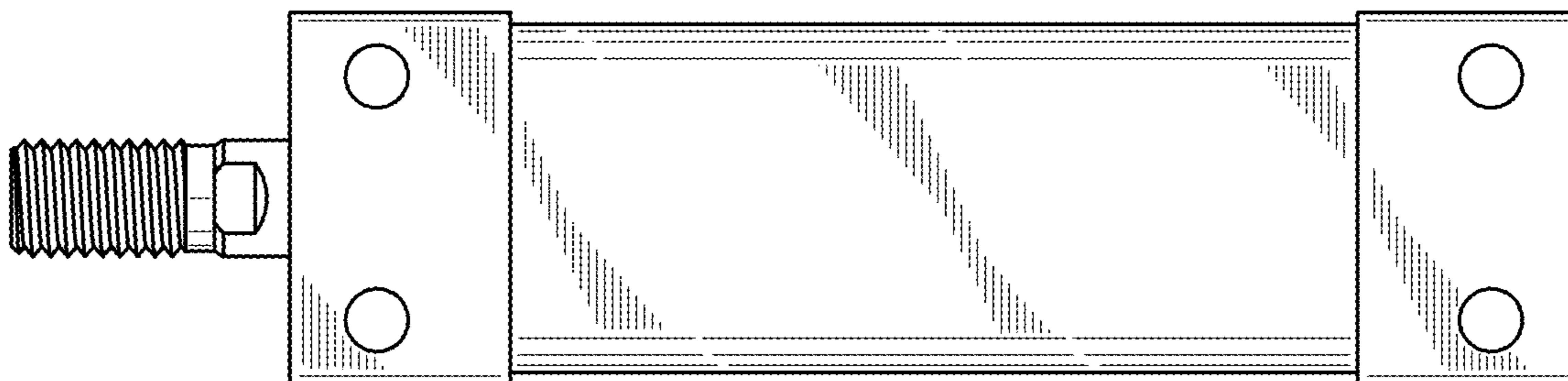

FIG. 44

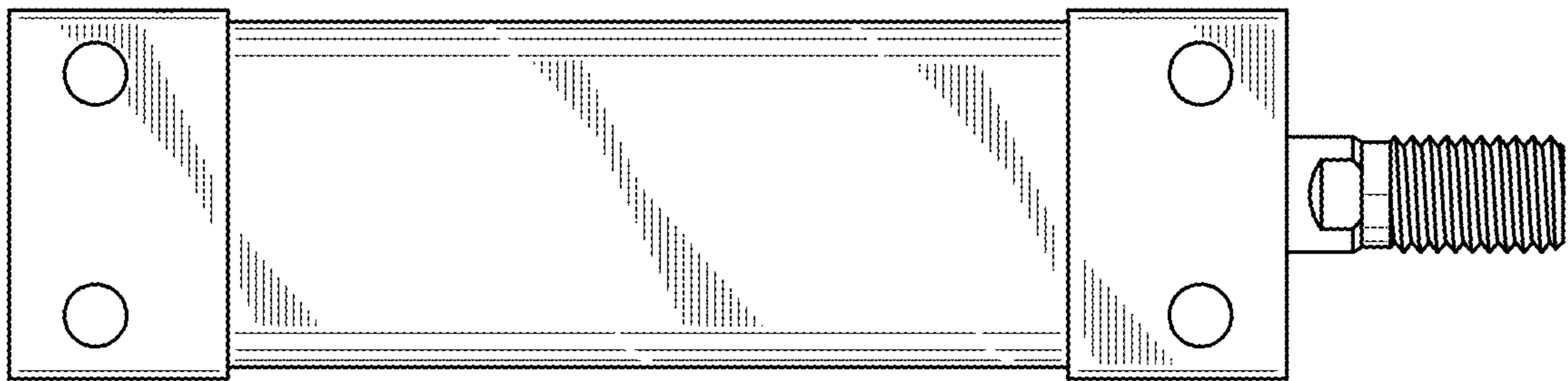

FIG. 45

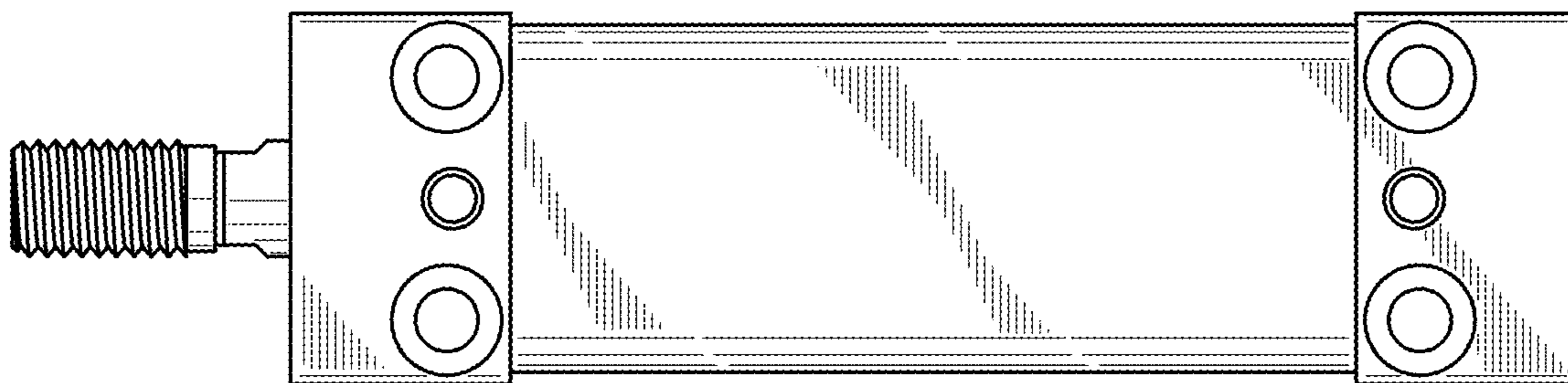

FIG. 46

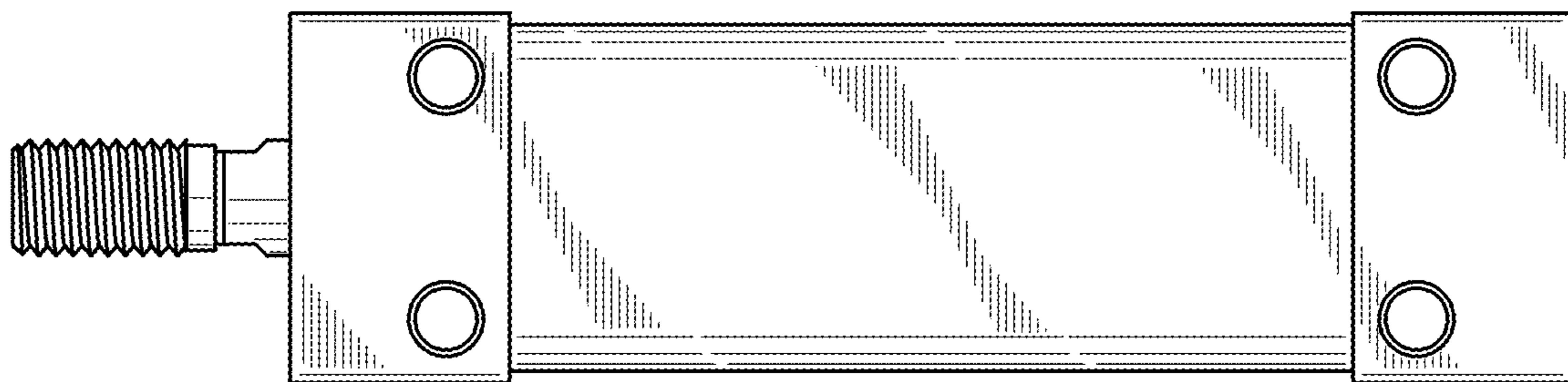



FIG. 47

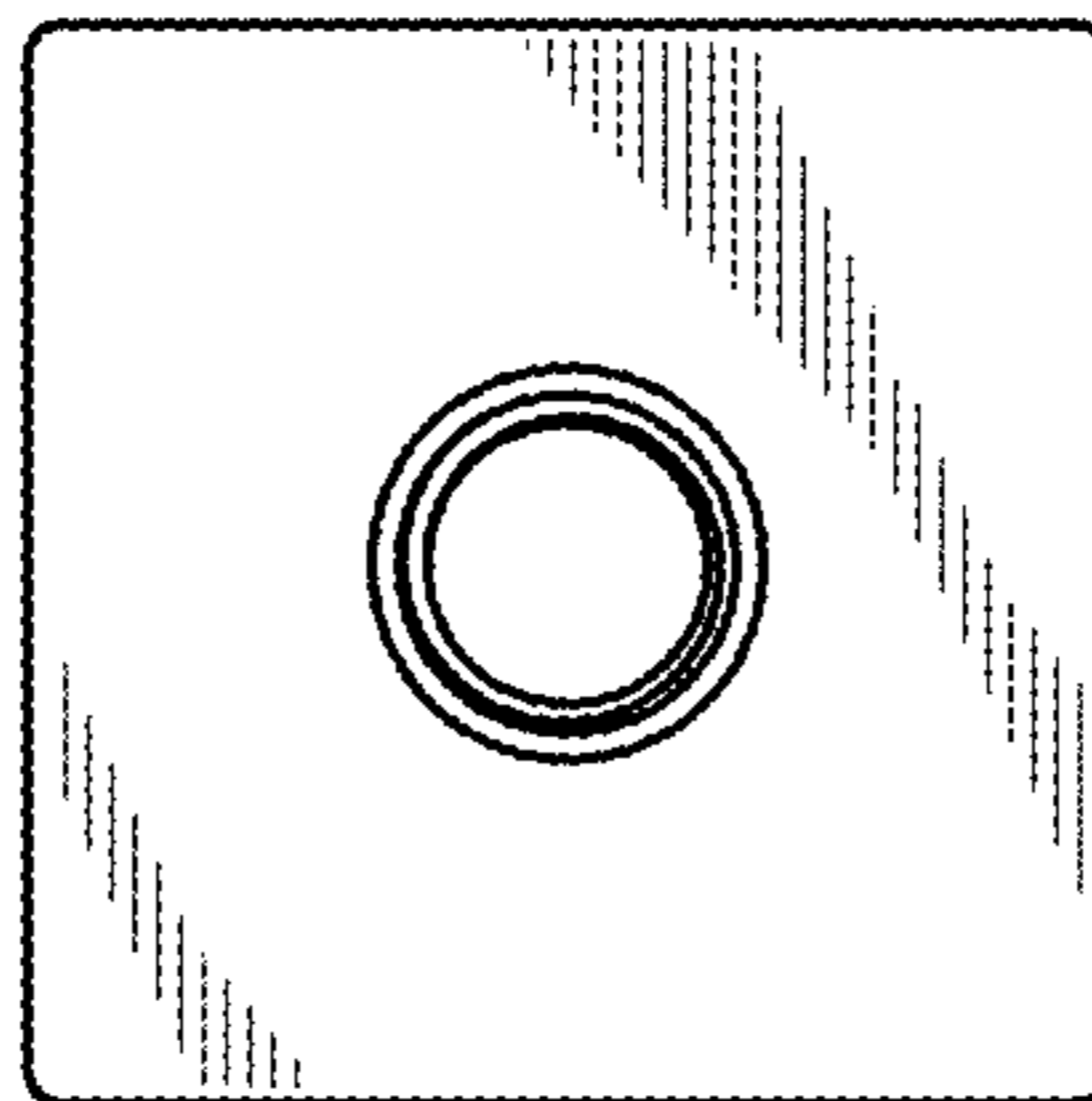
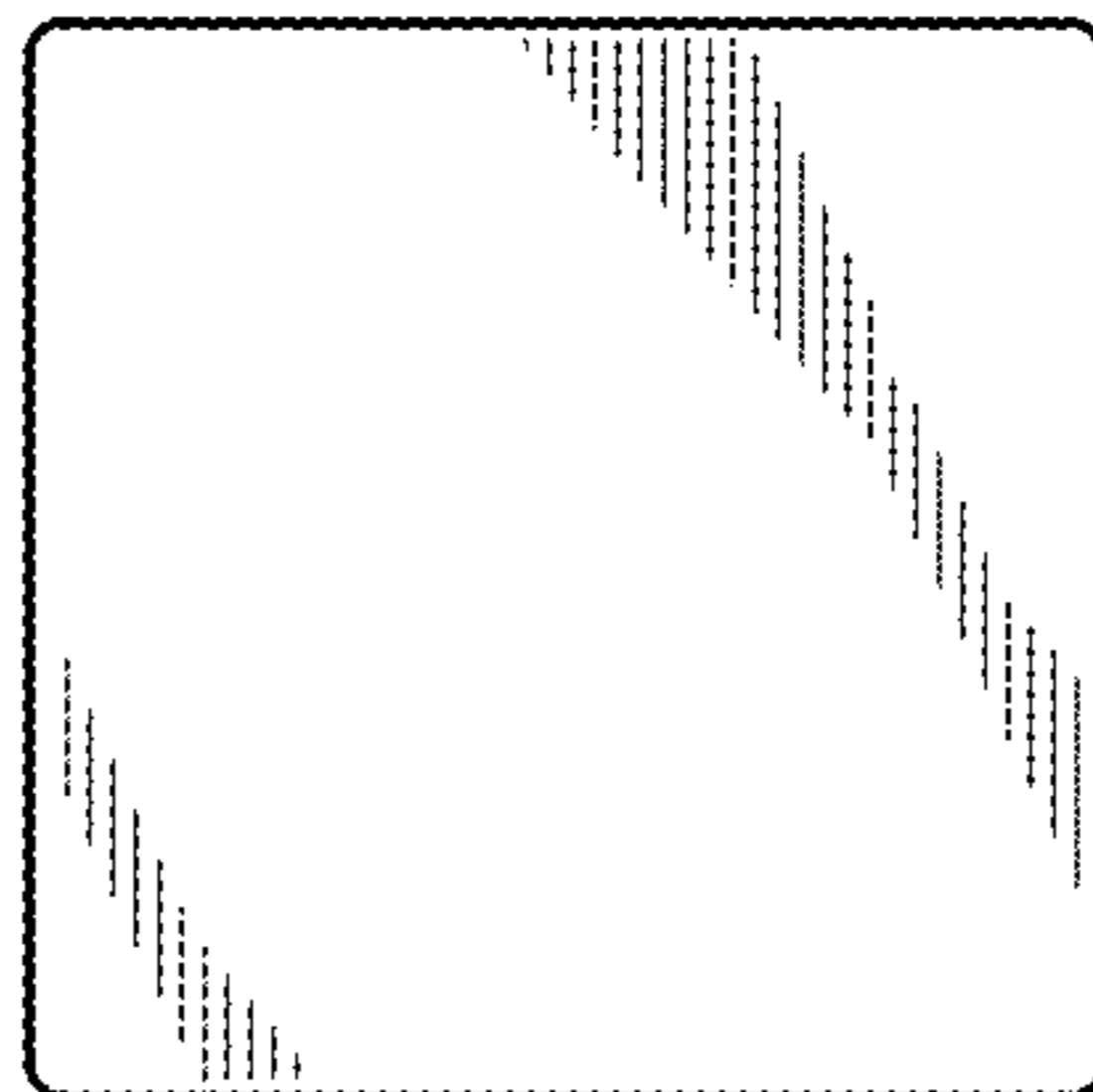

FIG. 48



UNITED STATES PATENT AND TRADEMARK OFFICE  
**CERTIFICATE OF CORRECTION**

PATENT NO. : D805,560 S  
APPLICATION NO. : 29/577928  
DATED : December 19, 2017  
INVENTOR(S) : Masayuki Kudo et al.

Page 1 of 1

It is certified that error appears in the above-identified patent and that said Letters Patent is hereby corrected as shown below:

On the Title Page

In the Description of the Drawings:

In the right-hand column, insert the Description for Fig. 10 as follows:

-- Fig. 10 is a rear, bottom and right side perspective view of FIG. 9; --.

In the right-hand column, correct the Description for Figs. 11 through 16 to read as follows:

-- Fig. 11 is a front view of FIG. 9;

Fig. 12 is a rear view of FIG. 9;

Fig. 13 is a top plan view of FIG. 9;

Fig. 14 is a bottom plan view of FIG. 9;

Fig. 15 is a left side view of FIG. 9;

Fig. 16 is a right side view of FIG. 9; --.

Signed and Sealed this  
Twenty-fourth Day of April, 2018

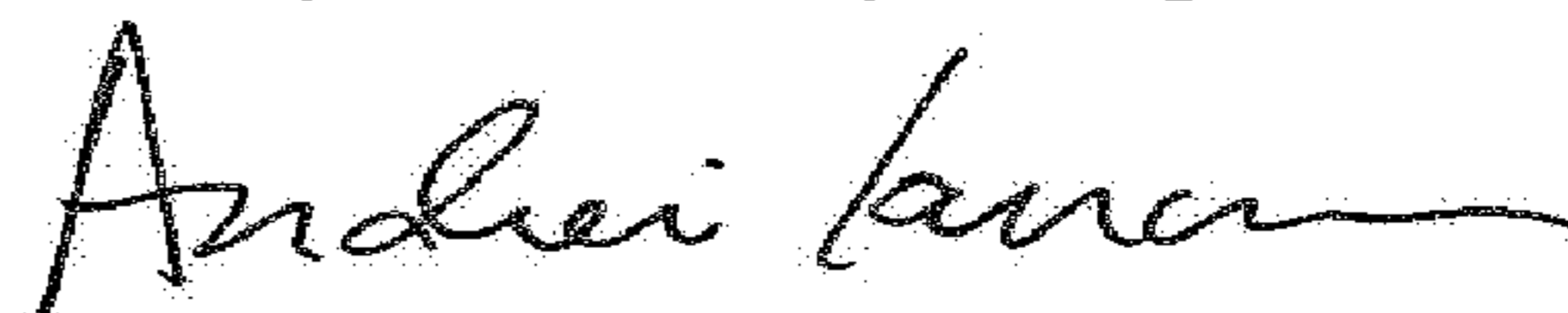

Andrei Iancu  
Director of the United States Patent and Trademark Office