



US00D805427S

(12) **United States Design Patent** (10) **Patent No.:** **US D805,427 S**  
**Steinberger** (45) **Date of Patent:** **\*\* Dec. 19, 2017**

(54) **LOCKING STRAP DESIGN**  
(71) Applicant: **Richard Ned Steinberger**, Nobleboro, ME (US)  
(72) Inventor: **Richard Ned Steinberger**, Nobleboro, ME (US)  
(73) Assignee: **D'Addario & Company, Inc.**, Farmingdale, NY (US)  
(\*\*) Term: **15 Years**  
(21) Appl. No.: **29/583,536**  
(22) Filed: **Nov. 7, 2016**  
(51) **LOC (10) Cl.** ..... **02-07**  
(52) **U.S. Cl.**  
USPC ..... **D11/218**  
(58) **Field of Classification Search**  
USPC ..... D11/1-2, 200-201, 206-210, 214-218;  
24/163 R, 169-171, 173, 177-179, 191,  
24/194-195, 197, 200, 614-616, 625,  
24/198, 578.11, 578.1, 163 K, 114;  
D2/853, 624  
CPC ..... A44B 11/26; A44B 11/25; A44B 11/06;  
A44B 11/04; A44B 11/01; A44B 11/001;  
A44B 11/10  
See application file for complete search history.

(56) **References Cited**  
U.S. PATENT DOCUMENTS  
D111,854 S \* 10/1938 Kratz ..... D11/201  
2,271,471 A \* 1/1942 Anderson ..... A44B 11/06  
24/321

3,279,019 A \* 10/1966 Eubank ..... B60R 22/18  
24/200  
4,052,772 A \* 10/1977 Tolfen ..... B60R 22/24  
165/47  
D364,126 S \* 11/1995 Ochiai ..... D11/200  
D373,975 S \* 9/1996 Anscher ..... D11/218  
D389,779 S \* 1/1998 Poynter ..... D11/218  
D435,807 S \* 1/2001 Anscher ..... D11/200  
7,045,694 B2 \* 5/2006 Yasunori ..... A44B 11/2584  
24/633  
D581,314 S \* 11/2008 Janz ..... D11/200  
D637,942 S \* 5/2011 Lee ..... D11/218  
D647,424 S \* 10/2011 Kolasa ..... D11/218  
D647,425 S \* 10/2011 Kolasa ..... D11/218  
D647,819 S \* 11/2011 Kolasa ..... D11/218  
D724,995 S \* 3/2015 Paik ..... D11/216  
D728,416 S \* 5/2015 Kolasa ..... D11/216

\* cited by examiner  
*Primary Examiner* — Ralf T Seifert  
(74) *Attorney, Agent, or Firm* — Law Offices of Daniel A. Tesler, LLC

(57) **CLAIM**  
The ornamental design for a locking strap design, as shown and described.

**DESCRIPTION**  
FIG. 1 is a perspective view of the locking strap showing my new design;  
FIG. 2 is a top plan view thereof;  
FIG. 3 is a bottom plan view thereof;  
FIG. 4 is a right side view with the left side view being a mirror image thereof;  
FIG. 5 is a front view thereof; and,  
FIG. 6 is a rear view thereof.

**1 Claim, 4 Drawing Sheets**

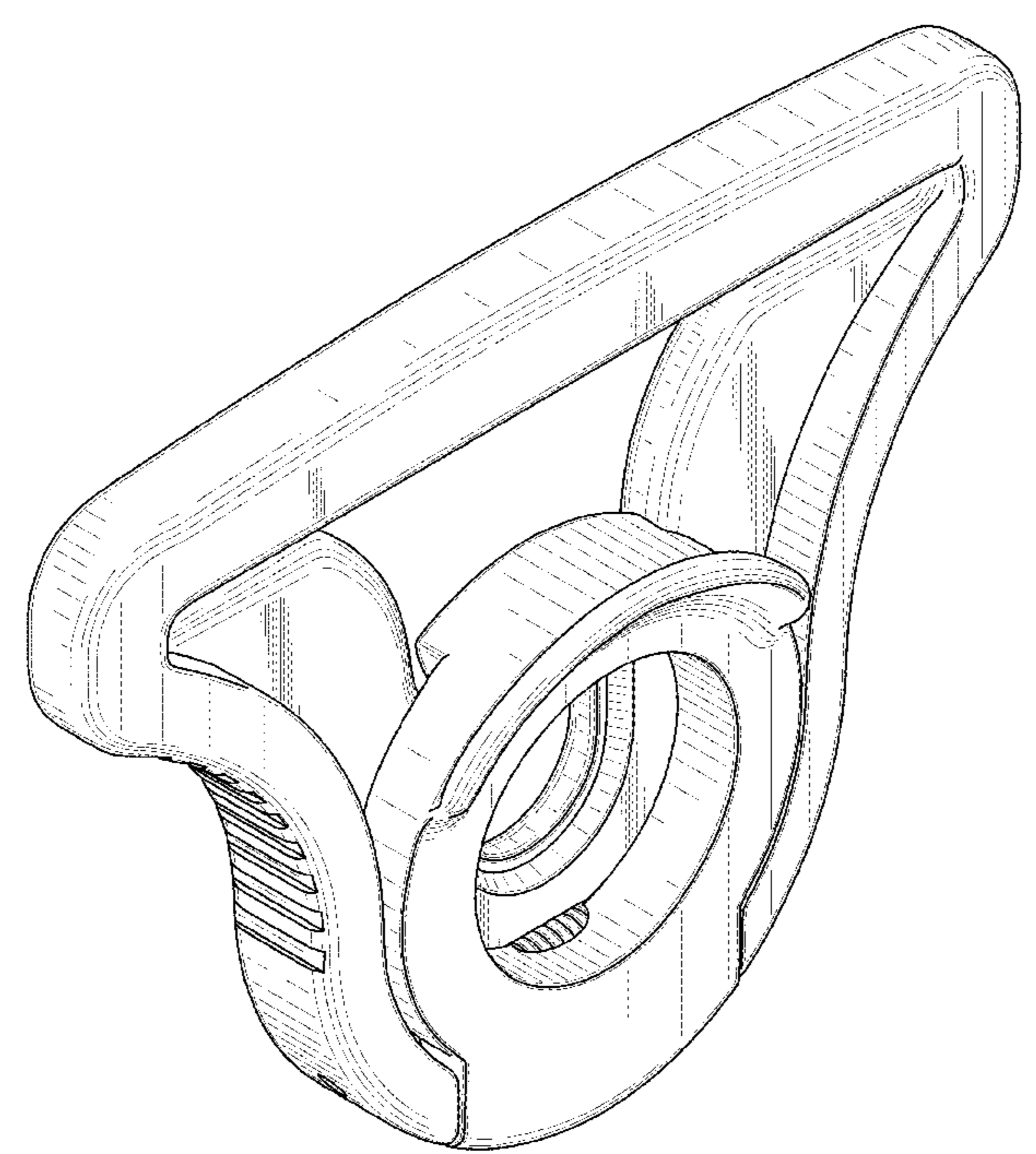
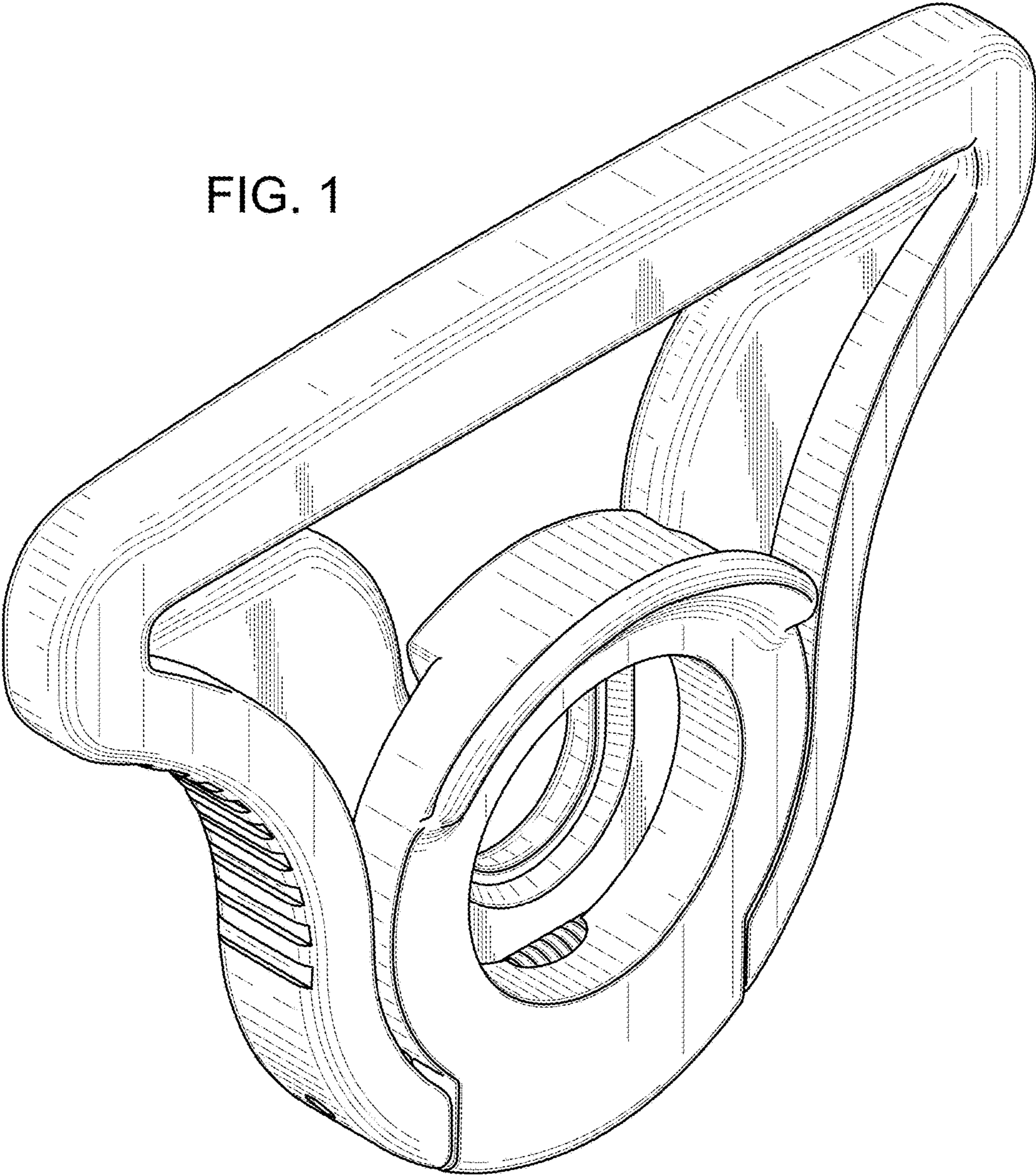

FIG. 1



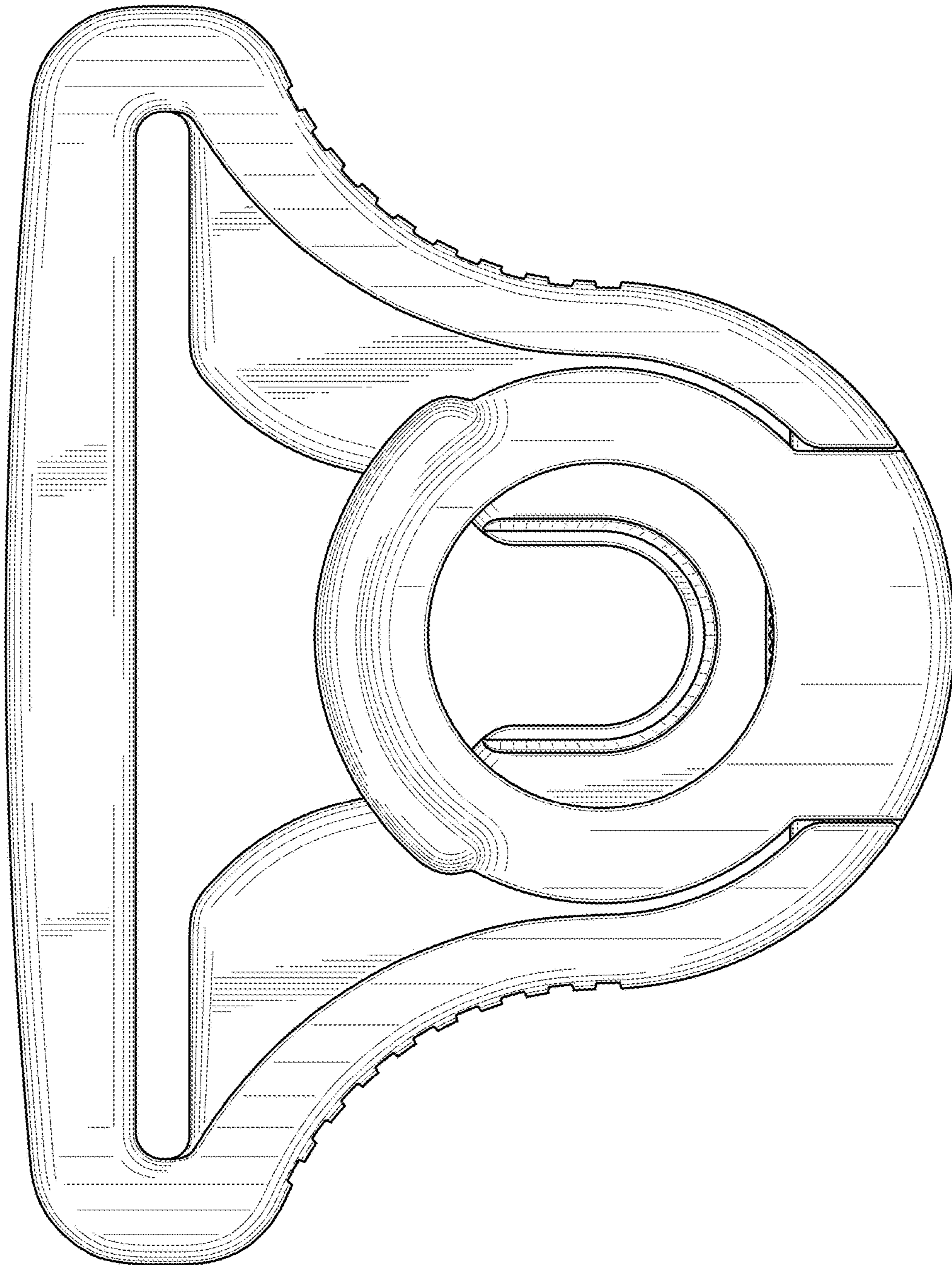

FIG. 2

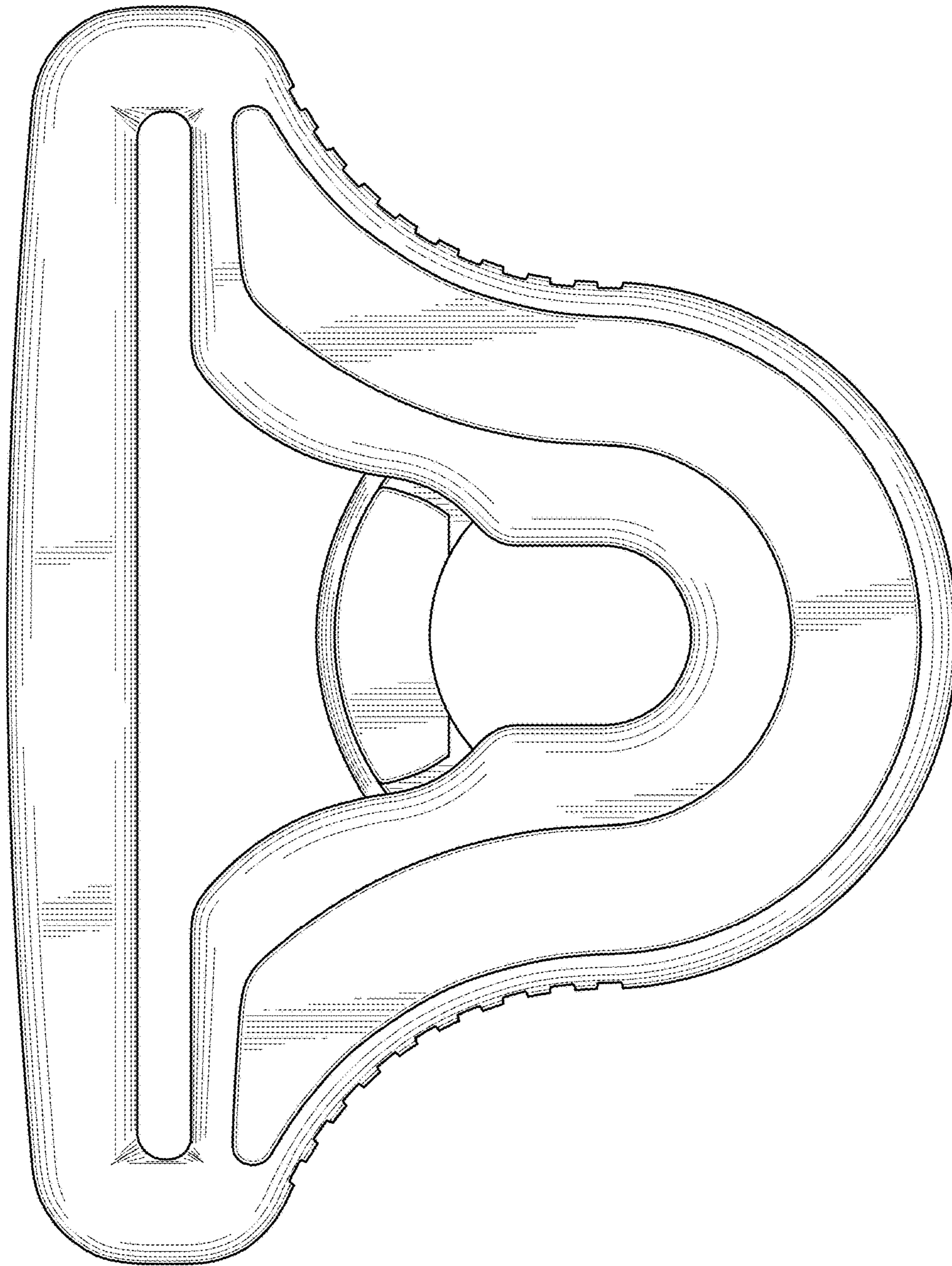

FIG. 3

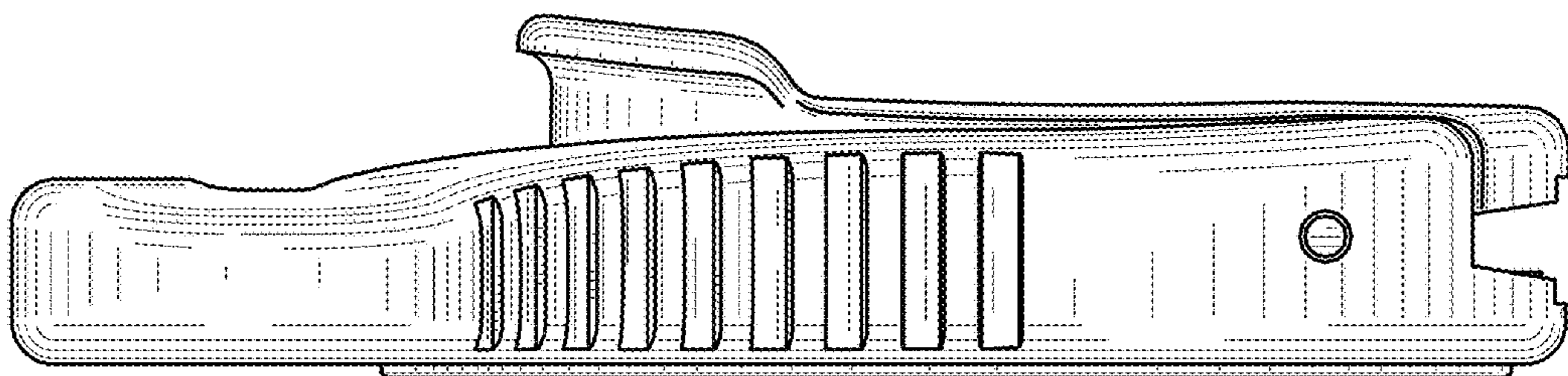

FIG. 4

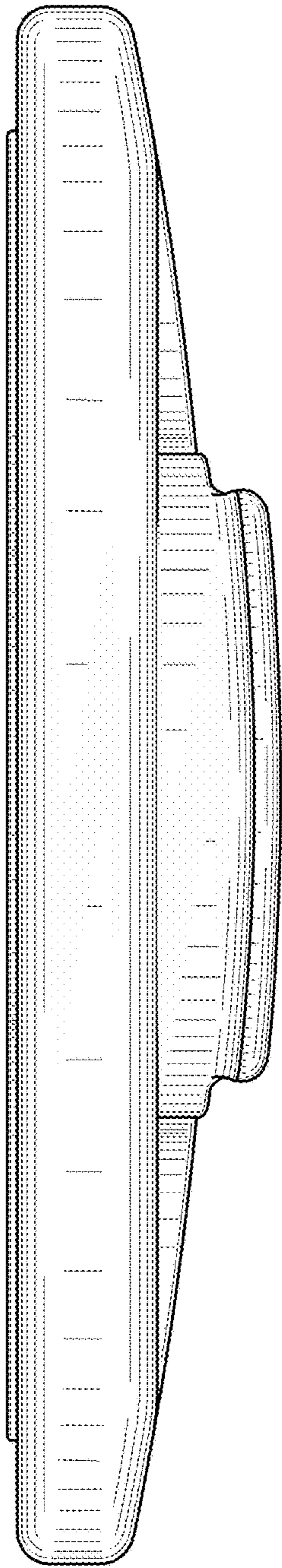

FIG. 5

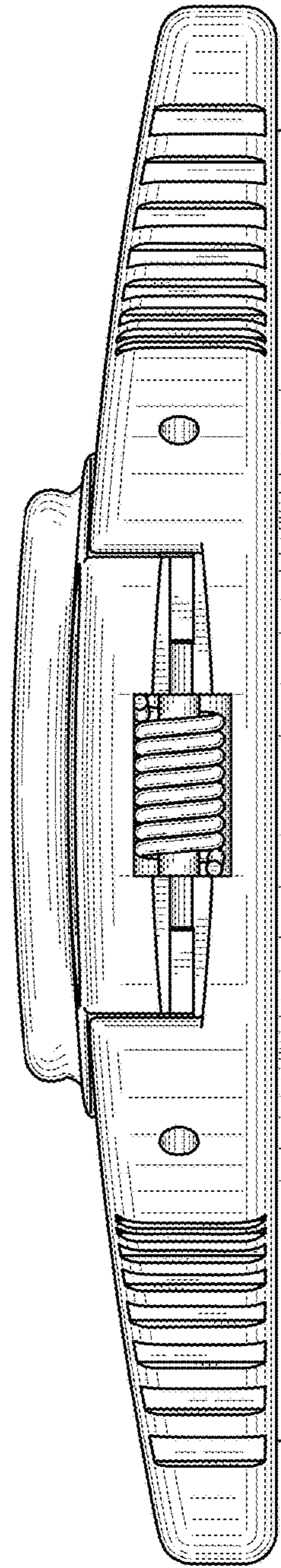

FIG. 6